

Aligned on  
Class 11 & 12  
Syllabus

**40**  
Years  
1978-2017

# JEE ADVANCED

(IIT-JEE) + 16 Yrs (2002 - 2017)

# JEE MAIN (AIEEE)

with FREE ebook

13th EDITION

Must for JEE Main, Advanced,  
BITSAT & Other State  
Engg. Exams

**23 Topics**

**9 Types**

**3200+** QUESTIONS

# CHEMISTRY

Topic-wise Solved Papers

Dr. O. P. Agarwal  
Er. Deepak Agarwal

- Corp. Office : 45, 2nd Floor, Maharishi Dayanand Marg, Corner Market, Malviya Nagar, New Delhi-110017  
Tel. : 011-26691021 / 26691713



Typeset by Disha DTP Team

## How to access the ebook(s)?

### Educore

#### INSTRUCTIONS

1. Mail your Order ID at [ebooks.support@aiets.co.in](mailto:ebooks.support@aiets.co.in) to get the 16 digit Access Code.
2. Go to [www.educoreonline.com/register.htm](http://www.educoreonline.com/register.htm)
3. Enter your details along with your 16 digit Access Code.
4. Click Register & you would be successfully redirected to the Login Page.

**Note: If you are already registered with us, you just have to login (<http://www.educoreonline.com/login.htm>) & enter your new 16 Character Unique Code under your Account Section.**

5. Login with your registered email ID & password.
6. You can now view you e-book(s) under your Library.
7. You can read your e-books either Online or Offline. For offline, simply download our Educore App once & download the e-books inside the app. Educore App is available for Windows Desktop, IOS & Android.
8. Educore works best in Desktop, Laptop, 7" & 10" tablets.
9. Contact us at [support@educoreonline.com](mailto:support@educoreonline.com) for any further assistance.

**Note: This app is not accessible on Mobiles.**

## **DISHA PUBLICATION**

**ALL RIGHTS RESERVED**

© Reserved

*No part of this publication may be reproduced in any form without prior permission of the publisher. The author and the publisher do not take any legal responsibility for any errors or misrepresentations that might have crept in. We have tried and made our best efforts to provide accurate up-to-date information in this book.*

For further information about the books from DISHA,  
Log on to [www.dishapublication.com](http://www.dishapublication.com) or email to [info@dishapublication.com](mailto:info@dishapublication.com)

# Index

- **JEE Advanced 2017 Solved Paper** **1 - 12**
- **JEE Main 2017 Solved Paper** **2017-1 - 2017-7**

**c-1 – c-192**

## **CHAPTERS BASED ON CLASS 11<sup>th</sup> SYLLABUS**

1. Some Basic Concepts of Chemistry 1 - 6
2. Structure of Atom 7 - 14
3. Classification of Elements and Periodicity in Properties 15 - 18
4. Chemical Bonding and Molecular Structure 19 - 24
5. States of Matter 25 - 32
6. Thermodynamics 33 - 40
7. Equilibrium 41 - 50
8. The s-Block Elements 51 - 54
9. Organic Chemistry — Some Basic Principles & Techniques 55 - 68
10. Hydrocarbons 69 - 76

## **CHAPTERS BASED ON CLASS 12<sup>th</sup> SYLLABUS**

11. The Solid State & Surface Chemistry 77 - 82
12. Solutions 83 - 88
13. Electrochemistry 89 - 98
14. Chemical Kinetics & Nuclear Chemistry 99 - 108
15. General Principles and Processes of Isolation of Elements 109 - 112
16. The p-Block Elements 113 - 126
17. The d- and f-Block Elements & Co-ordination Compounds 127 - 140
18. Haloalkanes and Haloarenes 141 - 144
19. Alcohols, Phenols and Ethers 145 - 152
20. Aldehydes, Ketones and Carboxylic Acids 153 - 168
21. Compounds Containing Nitrogen 169 - 180
22. Carbohydrates, Amino Acids, Polymers  
& Miscellaneous Match the Following 181 - 188
23. Analytical Chemistry 189 - 192

# Solutions & Explanations

**c-s-1 – c-s-268**

1. Some Basic Concepts of Chemistry	1 - 16
2. Structure of Atom	17 - 25
3. Classification of Elements and Periodicity in Properties	26 - 29
4. Chemical Bonding and Molecular Structure	30 - 43
5. States of Matter	44 - 54
6. Thermodynamics	55 - 64
7. Equilibrium	65 - 84
8. The s-Block Elements	85 - 88
9. Organic Chemistry — Some Basic Principles & Techniques	89 - 104
10. Hydrocarbons	105 - 117
11. The Solid State & Surface Chemistry	118 - 123
12. Solutions	124 - 133
13. Electrochemistry	134 - 148
14. Chemical Kinetics & Nuclear Chemistry	149 - 161
15. General Principles and Processes of Isolation of Elements	162 - 164
16. The p-Block Elements	165 - 180
17. The d- and f-Block Elements & Co-ordination Compounds	181 - 197
18. Haloalkanes and Haloarenes	198 - 203
19. Alcohols, Phenols and Ethers	204 - 215
20. Aldehydes, Ketones and Carboxylic Acids	216 - 239
21. Compounds Containing Nitrogen	240 - 253
22. Carbohydrates, Amino Acids, Polymers & Miscellaneous Match the Following	254 - 260
23. Analytical Chemistry	261 - 268

\* The chapters have been divided as per the Class 11<sup>th</sup> & 12<sup>th</sup> syllabus followed by the NCERT books. Some of the chapters which are split in the class 11<sup>th</sup> & 12<sup>th</sup> syllabus in NCERT have been combined. There might be certain topics/ chapters which are not covered in NCERT but are a part of JEE Advanced/IIT-JEE syllabus.

# JEE ADVANCED 2017 - CHEMISTRY

## PAPER - 1

### SECTION - I

This section contains 7 questions. Each question has 4 options (A), (B), (C) and (D). **ONE or MORE THAN ONE** of these four options is (are) correct.

- An ideal gas is expanded from  $(p_1, V_1, T_1)$  to  $(p_2, V_2, T_2)$  under different conditions. The correct statement(s) among the following is(are)
  - The work done on the gas is maximum when it is compressed irreversibly from  $(p_2, V_2)$  to  $(p_1, V_1)$  against constant pressure  $p_1$
  - If the expansion is carried out freely, it is simultaneously both isothermal as well as adiabatic
  - The work done by the gas is less when it is expanded reversibly from  $V_1$  to  $V_2$  under adiabatic conditions as compared to that when expanded reversibly from  $V_1$  to  $V_2$  under isothermal conditions
  - The change in internal energy of the gas is (i) zero, if it is expanded reversibly with  $T_1 = T_2$ , and (ii) positive, if it is expanded reversibly under adiabatic conditions with  $T_1 \neq T_2$
- For a solution formed by mixing liquids L and M, the vapour pressure of L plotted against the mole fraction of M in solution is shown in the following figure. Here  $x_L$  and  $x_M$  represent mole fractions of L and M, respectively, in the solution. The correct statement(s) applicable to this system is (are)

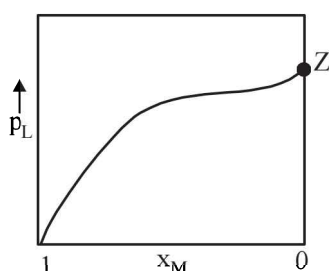

- The point Z represents vapour pressure of pure liquid M and Raoult's law is obeyed from  $x_L = 0$  to  $x_L = 1$
  - The point Z represents vapour pressure of pure liquid L and Raoult's law is obeyed when  $x_L \rightarrow 1$
  - The point Z represents vapour pressure of pure liquid M and Raoult's law is obeyed when  $x_L \rightarrow 0$
  - Attractive intermolecular interactions between L-L in pure liquid L and M-M in pure liquid M are stronger than those between L-M when mixed in solution.
- The correct statement(s) about the oxoacids,  $\text{HClO}_4$  and  $\text{HClO}$ , is(are)
    - The central atom in both  $\text{HClO}_4$  and  $\text{HClO}$  is  $\text{sp}^3$  hybridized

- $\text{HClO}_4$  is more acidic than  $\text{HClO}$  because of the resonance stabilization of its anion
  - $\text{HClO}_4$  is formed in the reaction between  $\text{Cl}_2$  and  $\text{H}_2\text{O}$
  - The conjugate base of  $\text{HClO}_4$  is weaker base than  $\text{H}_2\text{O}$
- The colour of the  $\text{X}_2$  molecules of group 17 elements changes gradually from yellow to violet down the group. This is due to
    - The physical state of  $\text{X}_2$  at room temperature changes from gas to solid down the group
    - Decrease in ionization energy down the group
    - Decrease in  $\pi^* - \sigma^*$  gap down the group
    - Decrease in HOMO-LUMO gap down the group
  - Addition of excess aqueous ammonia to a pink coloured aqueous solution of  $\text{MCl}_2 \cdot 6\text{H}_2\text{O}(\text{X})$  and  $\text{NH}_4\text{Cl}$  gives an octahedral complex Y in the presence of air. In aqueous solution, complex Y behaves as 1:3 electrolyte. The reaction of X with excess  $\text{HCl}$  at room temperature results in the formation of a blue coloured complex Z. The calculated spin only magnetic moment of X and Z is 3.87 B.M., whereas it is zero for complex Y. Among the following options, which statement(s) is(are) correct?
    - Addition of silver nitrate to Y gives only two equivalents of silver chloride
    - The hybridization of the central metal ion in Y is  $d^2\text{sp}^3$
    - Z is a tetrahedral complex
    - When X and Z are in equilibrium at  $0^\circ\text{C}$ , the colour of the solution is pink
  - The IUPAC name(s) of the following compound is(are)

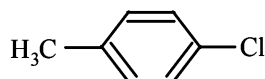

- 1-chloro-4-methylbenzene
  - 4-chlorotoluene
  - 4-methylchlorobenzene
  - 1-methyl-4-chlorobenzene
- The correct statement(s) for the following addition reactions is(are)

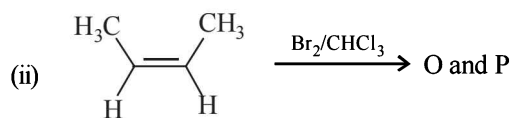
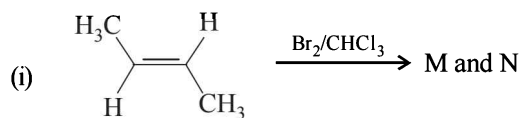

2

## JEE Advanced 2017 Solved Paper

- (A) O and P are identical molecules  
 (B) (M and O) and (N and P) are two pairs of diastereomers  
 (C) (M and O) and (N and P) are two pairs of enantiomers  
 (D) Bromination proceeds through *trans*-addition in both the reactions

## SECTION - II

This section contains 5 questions. The answer to each question is a **SINGLE DIGIT INTEGER** ranging from 0 to 9, both inclusive.

8. A crystalline solid of a pure substance has a face-centred cubic structure with a cell edge of 400 pm. If the density of the substance in the crystal is  $8 \text{ g cm}^{-3}$ , then the number of atoms present in 256 g of the crystal is  $N \times 10^{24}$ . The value of N is
9. The conductance of a 0.0015 M aqueous solution of a weak monobasic acid was determined by using a conductivity cell consisting of platinized Pt electrodes. The distance between the electrodes is 120 cm with an area of cross section of  $1 \text{ cm}^2$ . The conductance of this solution was found to be  $5 \times 10^{-7} \text{ S}$ . The pH of the solution is 4. The value of limiting molar conductivity ( $\Lambda_m^0$ ) of this weak monobasic acid in

- aqueous solution is  $Z \times 10^2 \text{ S cm}^{-1} \text{ mol}^{-1}$ . The value of Z is
10. The sum of the number of lone pairs of electrons on each central atom in the following species is  $[\text{TeBr}_6]^{2-}$ ,  $[\text{BrF}_2]^+$ ,  $\text{SNF}_3$  and  $[\text{XeF}_3]^-$  (Atomic numbers: N = 7, F = 9, S = 16, Br = 35, Te = 52, Xe = 54)
11. Among  $\text{H}_2$ ,  $\text{He}_2^+$ ,  $\text{Li}_2$ ,  $\text{Be}_2$ ,  $\text{B}_2$ ,  $\text{C}_2$ ,  $\text{N}_2$ ,  $\text{O}_2^-$  and  $\text{F}_2$ , the number of diamagnetic species is (Atomic numbers: H = 1, He = 2, Li = 3, Be = 4, B = 5, C = 6, N = 7, O = 8, F = 9)
12. Among the following, the number of aromatic compound(s) is

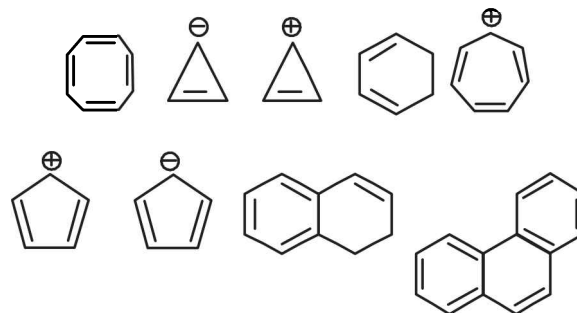

## SECTION - III

This section contains 6 questions of **MATCHING TYPE**, contains two tables each having 3 columns and 4 rows. Based on each table, there are three questions. Each question has four options (A), (B), (C) and (D) **ONLY ONE** of these four option is correct.

(Qs. 13-15) : By appropriately matching the information given in the three columns of the following table.

The wave function,  $\psi_{n,l,m_l}$  is a mathematical function whose value depends upon spherical polar coordinates ( $r, \theta, \phi$ ) of the electron and characterized by the quantum numbers  $n, l$  and  $m_l$ . Here  $r$  is distance from nucleus,  $\theta$  is colatitude and  $\phi$  is azimuth. In the mathematical functions given in the table,  $Z$  is atomic number and  $a_0$  is Bohr radius.

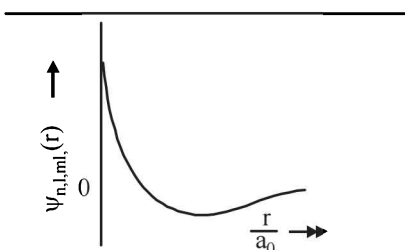
Column 1	Column 2	Column 3
(i) 1s orbital	(i) $\psi_{n,l,m_l} \propto \left(\frac{Z}{a_0}\right)^{\frac{3}{2}} e^{-\left(\frac{Zr}{a_0}\right)}$	(P) 
(ii) 2s orbital	(ii) One radial node	(Q) Probability density at nucleus $\propto \frac{1}{a_0^3}$
(iii) 2p <sub>z</sub> orbital	(iii) $\psi_{n,l,m_l} \propto \left(\frac{Z}{a_0}\right)^{\frac{5}{2}} r e^{-\left(\frac{Zr}{2a_0}\right)} \cos \theta$	(R) Probability density is maximum at nucleus
(iv) 3d <sub>z^2</sub> orbital	(iv) xy-plane is a nodal plane	(S) Energy needed to excite electron from $n = 2$ state to $n = 4$ state is $\frac{27}{32}$ times the energy needed to excite electron from $n = 2$ state to $n = 6$ state

13. For the given orbital in Column 1, the only CORRECT combination for any hydrogen-like species is  
 (A) (I)(ii)(S)  
 (B) (IV)(iv)(R)  
 (C) (II)(ii)(P)  
 (D) (III)(iii)(P)
14. For hydrogen atom, the only CORRECT combination is  
 (A) (I)(i)(S)  
 (B) (II)(i)(Q)  
 (C) (I)(i)(P)  
 (D) (I)(iv)(R)
15. For He<sup>+</sup> ion, the only INCORRECT combination is  
 (A) (I)(i)(R)  
 (B) (II)(ii)(Q)  
 (C) (I)(iii)(R)  
 (D) (I)(i)(S)

(Qs. 16-18) : By appropriately matching the information given in the three columns of the following table.

Columns 1, 2 and 3 contain starting materials, reaction conditions, and type of reactions, respectively.

Column 1	Column 2	Column 3
(I) Toluene	(i) NaOH/Br <sub>2</sub>	(P) Condensation
(II) Acetophenone	(ii) Br <sub>2</sub> /hν	(Q) Carboxylation
(III) Benzaldehyde	(iii) (CH <sub>3</sub> CO) <sub>2</sub> O/ CH <sub>3</sub> COOK	(R) Substitution
(IV) Phenol	(iv) NaOH/CO <sub>2</sub>	(S) Haloform

16. For the synthesis of benzoic acid, the only CORRECT combination is  
 (A) (II)(i)(S) (B) (IV)(ii)(P)  
 (C) (I)(iv)(Q) (D) (III)(iv)(R)
17. The only CORRECT combination that gives two different carboxylic acids is  
 (A) (II)(iv)(R) (B) (IV)(iii)(Q)  
 (C) (III)(iii)(P) (D) (I)(i)(S)
18. The only CORRECT combination in which the reaction proceeds through radical mechanism is  
 (A) (III)(ii)(P) (B) (IV)(i)(Q)  
 (C) (II)(iii)(R) (D) (I)(ii)(R)

## PAPER - 2

### SECTION - I

This section contains 7 questions. Each question has 4 options (A), (B), (C) and (D). ONLY ONE of these four options is correct.

1. Pure water freezes at 273 K and 1 bar. The addition of 34.5 g of ethanol to 500 g of water changes the freezing point of the solution. Use the freezing point depression constant of water as 2 K kg mol<sup>-1</sup>. The figures shown below represent plots of vapour pressure (V.P.) versus temperature (T). [molecular weight of ethanol is 46 g mol<sup>-1</sup>] Among the following, the option representing change in the freezing point is

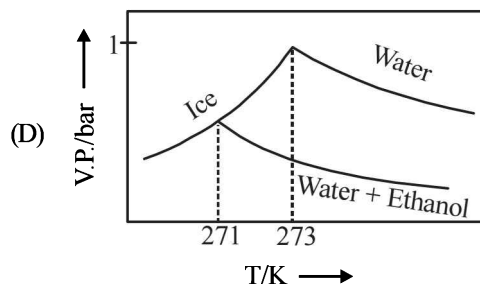
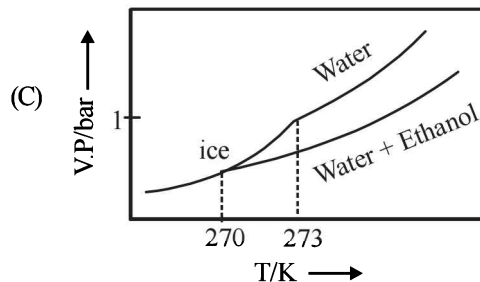
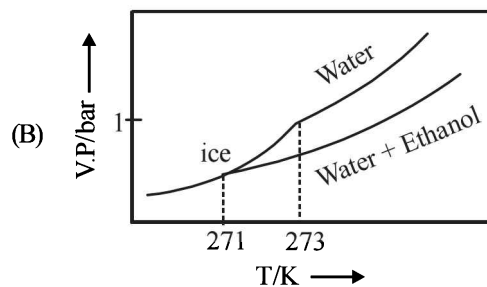
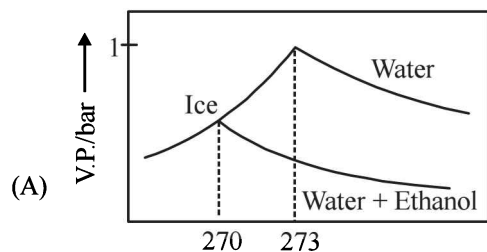

2. For the following cell,  
 $Zn(s) | ZnSO_4(aq) || CuSO_4(aq) | Cu(s)$   
 when the concentration of Zn<sup>2+</sup> is 10 times the concentration of Cu<sup>2+</sup>, the expression for ΔG (in J mol<sup>-1</sup>) is [F is Faraday constant; R is gas constant; T is temperature; E°(cell) = 1.1 V]  
 (A) 1.1F (B) 2.303RT - 2.2F  
 (C) 2.303RT + 1.1F (D) -2.2F



4

3. The standard state Gibbs free energies of formation of C(graphite) and C(diamond) at  $T = 298 \text{ K}$  are  $\Delta_f G^\circ [\text{C}(\text{graphite})] = 0 \text{ kJ mol}^{-1}$   
 $\Delta_f G^\circ [\text{C}(\text{diamond})] = 2.9 \text{ kJ mol}^{-1}$

The standard state means that the pressure should be 1 bar, and substance should be pure at a given temperature. The conversion of graphite [C(graphite)] to diamond [C(diamond)] reduces its volume by  $2 \times 10^{-6} \text{ m}^3 \text{ mol}^{-1}$ . If C(graphite) is converted to C(diamond) isothermally at  $T = 298 \text{ K}$ , the pressure at which C(graphite) is in equilibrium with C(diamond), is

[Useful information :  $1 \text{ J} = 1 \text{ kg m}^2 \text{ s}^{-2}$ ;  $1 \text{ Pa} = 1 \text{ kg m}^{-1} \text{ s}^{-2}$ ;  $1 \text{ bar} = 10^5 \text{ Pa}$ ]

- (A) 14501 bar (B) 58001 bar  
 (C) 1450 bar (D) 29001 bar
4. Which of the following combination will produce  $\text{H}_2$  gas?  
 (A) Fe Metal and conc.  $\text{HNO}_3$   
 (B) Cu metal and conc.  $\text{HNO}_3$   
 (C) Zn metal and  $\text{NaOH}(\text{aq})$   
 (D) Au metal and  $\text{NaCN}(\text{aq})$  in the presence of air
5. The order of the oxidation state of the phosphorus atom in  $\text{H}_3\text{PO}_2$ ,  $\text{H}_3\text{PO}_4$ ,  $\text{H}_3\text{PO}_3$  and  $\text{H}_4\text{P}_2\text{O}_6$  is  
 (A)  $\text{H}_3\text{PO}_3 > \text{H}_3\text{PO}_2 > \text{H}_3\text{PO}_4 > \text{H}_4\text{P}_2\text{O}_6$   
 (B)  $\text{H}_3\text{PO}_4 > \text{H}_3\text{PO}_2 > \text{H}_3\text{PO}_3 > \text{H}_4\text{P}_2\text{O}_6$   
 (C)  $\text{H}_3\text{PO}_4 > \text{H}_4\text{P}_2\text{O}_6 > \text{H}_3\text{PO}_3 > \text{H}_3\text{PO}_2$   
 (D)  $\text{H}_3\text{PO}_2 > \text{H}_3\text{PO}_3 > \text{H}_4\text{P}_2\text{O}_6 > \text{H}_3\text{PO}_4$
6. The major product of the following reaction is

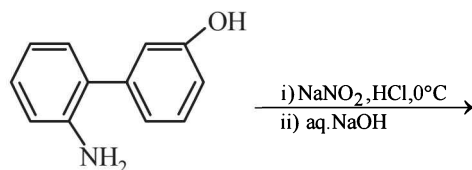

- (A)
- (B)
- (C)
- (D)

## JEE Advanced 2017 Solved Paper

7. The order of basicity among the following compounds is

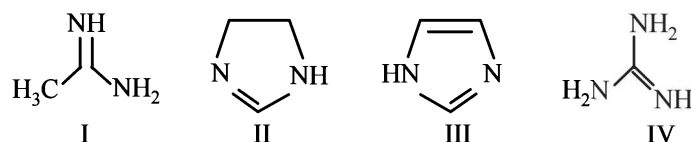

- (A)  $\text{II} > \text{I} > \text{IV} > \text{III}$  (B)  $\text{IV} > \text{II} > \text{III} > \text{I}$   
 (C)  $\text{IV} > \text{I} > \text{II} > \text{III}$  (D)  $\text{I} > \text{IV} > \text{III} > \text{II}$

## SECTION - II

This section contains 7 questions. Each question has 4 options (A), (B), (C) and (D). **ONE or MORE THAN ONE** of these four options is (are) correct.

8. The correct statement(s) about surface properties is(are)  
 (A) Adsorption is accompanied by decrease in enthalpy and decrease in entropy of the system  
 (B) The critical temperatures of ethane and nitrogen are 563 K and 126 K, respectively. The adsorption of ethane will be more than that of nitrogen on same amount of activated charcoal at a given temperature  
 (C) Cloud is an emulsion type of colloid in which liquid is dispersed phase and gas is dispersion medium  
 (D) Brownian motion of colloidal particles does not depend on the size of the particles but depends on viscosity of the solution
9. For a reaction taking place in a container in equilibrium with its surroundings, the effect of temperature on its equilibrium constant  $K$  in terms of change in entropy is described by  
 (A) With increase in temperature, the value of  $K$  for exothermic reaction decreases because the entropy change of the system is positive  
 (B) With increase in temperature, the value of  $K$  for endothermic reaction increases because unfavourable change in entropy of the surroundings decreases  
 (C) With increase in temperature, the value of  $K$  for endothermic reaction increases because the entropy change of the system is negative  
 (D) With increase in temperature, the value of  $K$  for exothermic reaction decreases because favourable change in entropy of the surroundings decreases
10. In a bimolecular reaction, the steric factor  $P$  was experimentally determined to be 4.5. The correct option(s) among the following is(are)  
 (A) The activation energy of the reaction is unaffected by the value of the steric factor  
 (B) Experimentally determined value of frequency factor is higher than that predicted by Arrhenius equation  
 (C) Since  $P = 4.5$ , the reaction will not proceed unless an effective catalyst is used  
 (D) The value of frequency factor predicted by Arrhenius equation is higher than that determined experimentally
11. For the following compounds, the correct statement(s) with respect to nucleophilic substitution reaction is(are)

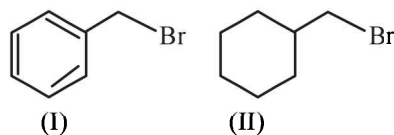

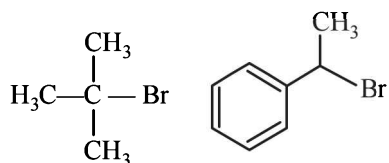

(III) (IV)

- (A) I and III follow  $S_N1$  mechanism  
 (B) I and II follow  $S_N2$  mechanism  
 (C) Compound IV undergoes inversion of configuration  
 (D) The order of reactivity for I, III and IV is : IV > I > III
12. Among the following, the correct statement(s) is(are)  
 (A)  $Al(CH_3)_3$  has the three-centre two-electron bonds in its dimeric structure  
 (B)  $BH_3$  has the three-centre two-electron bonds in its dimeric structure  
 (C)  $AlCl_3$  has the three-centre two-electron bonds in its dimeric structure  
 (D) The Lewis acidity of  $BCl_3$  is greater than that of  $AlCl_3$
13. The option(s) with only amphoteric oxides is(are)  
 (A)  $Cr_2O_3$ ,  $BeO$ ,  $SnO$ ,  $SnO_2$   
 (B)  $Cr_2O_3$ ,  $CrO$ ,  $SnO$ ,  $PbO$   
 (C)  $NO$ ,  $B_2O_3$ ,  $PbO$ ,  $SnO_2$   
 (D)  $ZnO$ ,  $Al_2O_3$ ,  $PbO$ ,  $PbO_2$
14. Compounds P and R upon ozonolysis produce Q and S, respectively. The molecular formula of Q and S is  $C_8H_8O$ . Q undergoes Cannizzaro reaction but not haloform reaction, whereas S undergoes haloform reaction but not Cannizzaro reaction

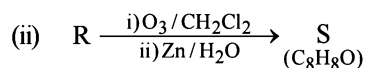
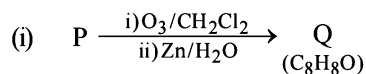

The option(s) with suitable combination of P and R, respectively, is(are)

- (A) and
- (B) and
- (C) and
- (D) and

## SECTION - I

This section contains 2 paragraphs, each describing theory, experiments, data etc. four questions related to the two paragraphs with two questions on each paragraph. Each question has only one correct answer among the four given options (A), (B), (C) and (D).

## PARAGRAPH 1

Upon heating  $KClO_3$  in the presence of catalytic amount of  $MnO_2$ , a gas W is formed. Excess amount of W reacts with white phosphorus to give X. The reaction of X with pure  $HNO_3$  gives Y and Z.

15. W and X are, respectively  
 (A)  $O_3$  and  $P_4O_6$  (B)  $O_2$  and  $P_4O_6$   
 (C)  $O_2$  and  $P_4O_{10}$  (D)  $O_3$  and  $P_4O_{10}$
16. Y and Z are, respectively  
 (A)  $N_2O_3$  and  $H_3PO_4$  (B)  $N_2O_5$  and  $HPO_3$   
 (C)  $N_2O_4$  and  $HPO_3$  (D)  $N_2O_4$  and  $H_3PO_3$

## PARAGRAPH 2

The reaction of compound P with  $CH_3MgBr$  (excess) in  $(C_2H_5)_2O$  followed by addition of  $H_2O$  gives Q. The compound Q on treatment with  $H_2SO_4$  at  $0^\circ C$  gives R. The reaction of R with  $CH_3COCl$  in the presence of anhydrous  $AlCl_3$  in  $CH_2Cl_2$  followed by treatment with  $H_2O$  produces compound S. [Et in compound P is ethyl group]

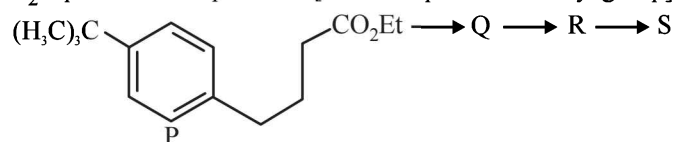

17. The product S is

- (A)
- (B)
- (C)
- (D)

18. The reactions, Q to R and R to S, are  
 (A) Dehydration and Friedel-Crafts acylation  
 (B) Aromatic sulfonation and Friedel-Crafts acylation  
 (C) Friedel-Crafts alkylation, dehydration and Friedel-Crafts acylation  
 (D) Friedel-Crafts alkylation and Friedel-Crafts acylation

# SOLUTIONS

## Paper - 1

1. (A, B, C)

(A) During adiabatic expansion, the final temperature is less than the initial temperature. Therefore the final volume in adiabatic expansion will also be less than the final volume in isothermal expansion. This can be graphically shown as

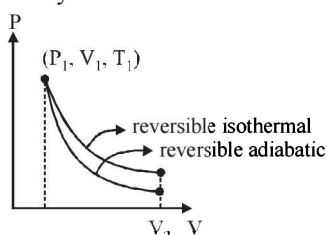

The magnitude of work done by the gas is equal to the area under the curve. As seen from the figure the area under curve in reversible isothermal is more. Hence, the magnitude of work done is lesser in adiabatic reversible expansion as compared to the corresponding work in isothermal expansion.

(B) In free expansion,  $P_{\text{ext}} = 0 \therefore W = 0$

If carried out isothermally ( $\Delta U = 0$ )  $\Rightarrow q = 0$  (Adiabatic);  
From I law

If carried out adiabatically ( $q = 0$ )  $\Rightarrow \Delta U = 0$  (Isothermal); From I law

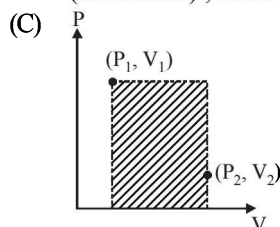

During irreversible compression, maximum work is done on the gas (corresponding to shaded area)

(D) When  $T_1 = T_2 \Rightarrow \Delta U = nC_V \Delta T = 0$

In reversible adiabatic expansion,  $T_2 < T_1$ .

$\therefore \Delta T = -ve \therefore \Delta U = -ve$

2. (B, D)

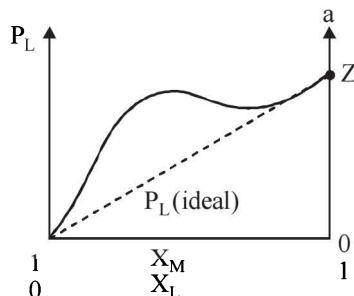

The graph representing +ve deviation from Raoult's law therefore  $M-L < M-M$  or  $L-L$

$P_L \geq P_L^0 X_L$

but when  $X_L = 1$ , mixture has almost pure liquid L so

$P_L = P_L^0$

3. (A, B, D)

(A) In both the acids central atom is  $sp^3$  hybridized.

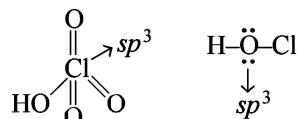

(B)  $\text{ClO}_4^-$  is resonance stabilized anion



Hence  $\text{HClO}_4$  is more acidic than  $\text{HClO}$ .

(C)  $\text{Cl}_2 + \text{H}_2\text{O} \rightarrow \text{HCl} + \text{HOCl}$

(D)  $\text{HClO}_4 + \text{H}_2\text{O} \rightarrow \text{ClO}_4^- + \text{H}_3\text{O}^+$   
Acid 1 Base 1 Base 1 acid 1

Since  $\text{H}_2\text{O}$  is accepting  $\text{H}^+$  from  $\text{HClO}_4$  so  $\text{H}_2\text{O}$  is stronger base compared to  $\text{ClO}_4^-$ .

4. (C, D)

The colour of  $X_2$  molecules of halogens is due to absorption of light in the visible region. The energy acquired in this manner excites the valence electron from the highest occupied molecular orbital (HOMO) to the lowest unoccupied molecular orbital (LUMO), i.e., transition from  $\pi^*$  to  $\sigma^*$  molecular orbital.

$X_2 : \sigma 1s^2, \sigma^* 1s^2, \sigma 2s^2, \sigma^* 2s^2, \sigma 2p_z^2, \pi 2p_x^2$

$$= \pi 2p_y^2, \frac{\pi^* 2p_x^2}{(\text{HOMO})}, \frac{\sigma^* 2p_z^0}{(\text{LUMO})}$$

5. (B, C, D)

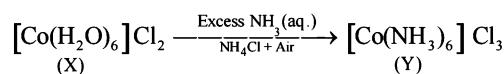

Pink Solution  
 $\downarrow$  HCl (excess)  
room temperature

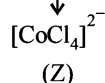

Blue colour (tetrahedral:  
 $sp^3$  as  $\text{Cl}^-$  is a weak field ligand)

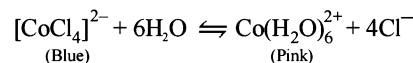

X and Z in equilibrium at  $0^\circ\text{C} \Rightarrow$  then equilibrium is shifted towards X, making colour of solution pink.

1 : 3 electrolyte  
( $d^2 sp^3$  hybridisation of central metal atom as  $\text{NH}_3$  is a strong field ligand)

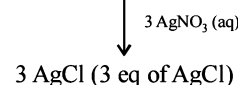

CHEMISTRY

6. (A, B)

IUPAC name

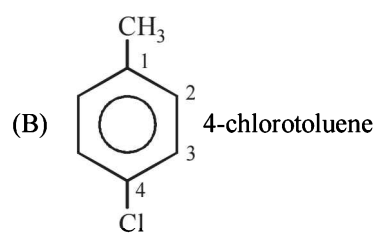
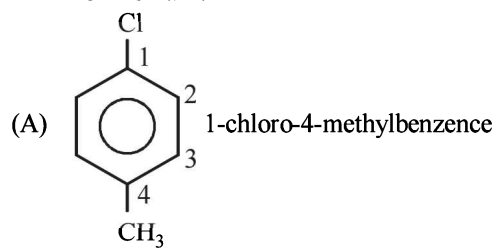

7. (B, D)

(B) Bromination proceeds through trans-addition in both the reactions.

M and N are identical, hence, M and O and N and P are two set of diastereomers.

(D)

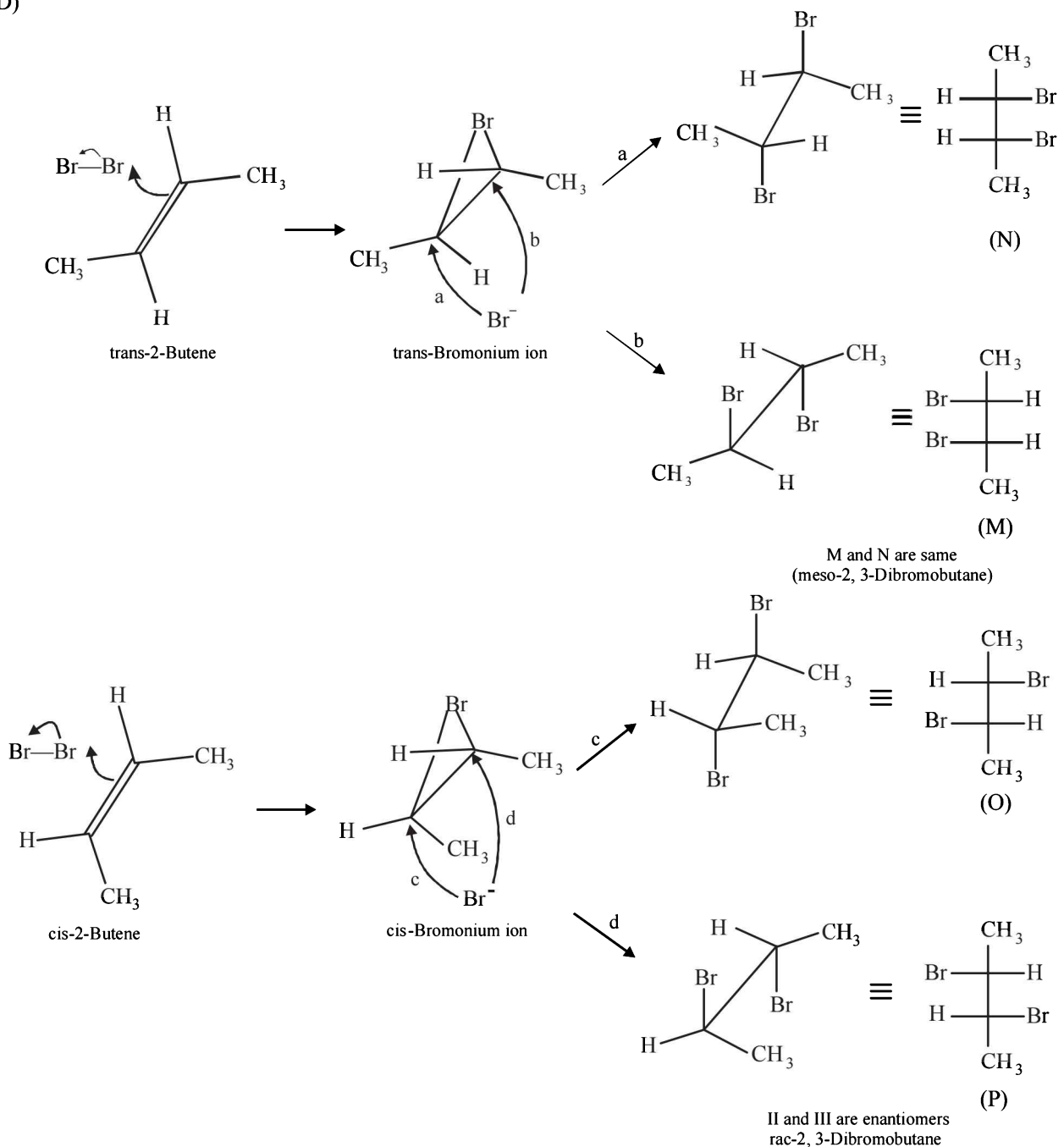

8

JEE Advanced 2017 Solved Paper

8. (2) Density (d) =  $\frac{Z \times M}{a^3 \times N_A}$  (d = density)

For FCC, Z = 4

Given a =  $4 \times 10^{-8}$  cm

$$8 = \frac{4 \times M}{(4 \times 10^{-10})^3 \times 6 \times 10^{23}}$$

$$M = \frac{8 \times (4 \times 10^{-8})^3 \times 6 \times 10^{23}}{4}$$

$$= \frac{8 \times 6 \times 10^{23} \times 64 \times 10^{-24}}{4}$$

$$\text{No. of atoms} = \frac{\text{wt}}{\text{Molar mass}} \times N_A$$

$$\frac{256 \times 10 \times 6 \times 10^{23}}{8 \times 6 \times 16} = 2 \times 10^{24}$$

∴ Value of N = 2

9. (6) The formula for conductance is  $G = \kappa \times \frac{a}{\ell}$

$$5 \times 10^{-7} = \kappa \times \frac{1}{120}$$

$$\kappa = 6 \times 10^{-5} \text{ s cm}^{-1}$$

$$\Lambda_m^c = \frac{\kappa \times 1000}{M} = \frac{6 \times 10^{-5} \times 1000}{0.0015} = 40$$

$$\therefore \text{pH} = 4$$

$$\therefore [\text{H}^+] = 10^{-4} = c\alpha = 0.0015 \alpha$$

$$\alpha = \frac{10^{-4}}{0.0015}$$

$$\alpha = \frac{\Lambda_m^c}{\Lambda_m^o} \Rightarrow \frac{10^{-4}}{0.0015} = 40$$

$$\Lambda_m^o = 6 \times 10^2 \text{ s cm}^2 \text{ mole}^{-1}$$

i.e., z = 6

10. (6) 

Species	Number of lone pairs on central atom
(i) $[\text{TeBr}_6]^{2-}$	1
(ii) $[\text{BrF}_2]^+$	2
(iii) $\text{SNF}_3$	0
(iv) $[\text{XeF}_3]^+$	3

Total number of lone pairs = 1 + 2 + 0 + 3 = 6

11. (6)  $(\text{H}_2, \text{Cl}_2, \text{Be}_2, \text{C}_2, \text{N}_2, \text{F}_2)$

$\text{H}_2$  :  $\sigma 1s^2$  (Diamagnetic)

$\text{He}_2^+$  :  $\sigma 1s^2, \sigma^* 1s^1$  (Paramagnetic)

$\text{Li}_2$  :  $\sigma 1s^2, \sigma^* 1s^2, \sigma 2s^2$  (Diamagnetic)

$\text{Be}_2$  :  $\sigma 1s^2, \sigma^* 1s^2, \sigma 2s^2, \sigma^* 2s^2$  (Diamagnetic)

$\text{B}_2$  :  $\sigma 1s^2, \sigma^* 1s^2, \sigma 2s^2, \sigma^* 2s^2, \pi 2p_x^1 = \pi 2p_y^1$   
(Paramagnetic)

$\text{C}_2$  :  $\sigma 1s^2, \sigma^* 1s^2, \sigma 2s^2, \sigma^* 2s^2, \pi 2p_x^2 = \pi 2p_y^2$   
(Diamagnetic)

$\text{N}_2$  :  $\sigma 1s^2, \sigma^* 1s^2, \sigma 2s^2, \sigma^* 2s^2, \pi 2p_x^2 = \pi 2p_y^2, \sigma 2p_z^2$   
(Diamagnetic)

$\text{O}_2^-$  :  $\sigma 1s^2, \sigma^* 1s^2, \sigma 2s^2, \sigma^* 2s^2, \pi 2p_z^2, \pi 2p_x^2$   
 $= \pi 2p_y^2, \pi^* 2p_x^2 = \pi^* 2p_y^1$   
(Paramagnetic)

$\text{F}_2$  :  $\sigma 1s^2, \sigma^* 1s^2, \sigma 2s^2, \sigma^* 2s^2, \sigma 2p_z^2, \pi 2p_x^2$   
 $= \pi 2p_y^2, \pi^* 2p_x^2 = \pi^* 2p_y^2$   
(Diamagnetic)

12. (5)

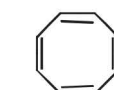

Non-aromatic



Anti-aromatic



Non-aromatic



Anti-aromatic

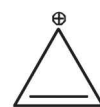

Aromatic



Aromatic



Aromatic

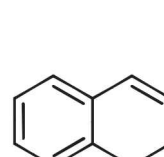

Aromatic

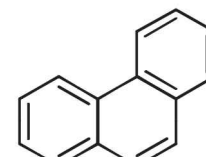

Aromatic

13. (C) 1s wave function for  $\text{He}^+$  is given by

$$\Psi_{(1s)} = \Psi_{n,\ell,m_\ell} = \frac{Z}{\sqrt{\pi a_0^3}} \exp\left(-\frac{Zr}{a_0}\right)$$

$$\text{or } \propto \left(\frac{Z}{a_0}\right)^{3/2} \exp\left[-\frac{Zr}{a_0}\right]$$

i.e., it is independent of  $\cos \theta$ .

The probability of finding an electron at zero distance from the nucleus is zero. The probability increases gradually as the distance increases, goes to maximum and then begins to decrease.

14. (A) For a given orbital with principal quantum number, n and azimuthal quantum number,  $\ell$ .  
Number of radial nodes =  $(n - \ell - 1)$

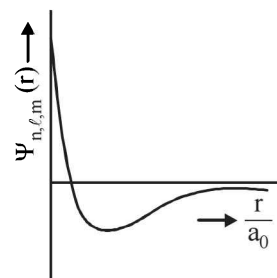

15. (C) Refer ans 13.  
Energy needed to excite from  $n = 2$  to  $n = 4$

$$\Delta E_{2-4} = 13.6 Z^2 \times \frac{3}{16} \text{ eV}$$

Similarly,

$$\Delta E_{2-6} = 13.6 Z^2 \times \frac{8}{36} \text{ eV}$$

on dividing

$$\frac{\Delta E_{2-4}}{\Delta E_{2-6}} = \frac{3}{16} \times \frac{36}{8} = \frac{27}{32}$$

16. (A) Alkylbenzenes when treated with  $\text{Br}_2$  at high temperature, in the presence of sunlight and absence of halogen carrier undergo **halogenation in the side chain**. Thus

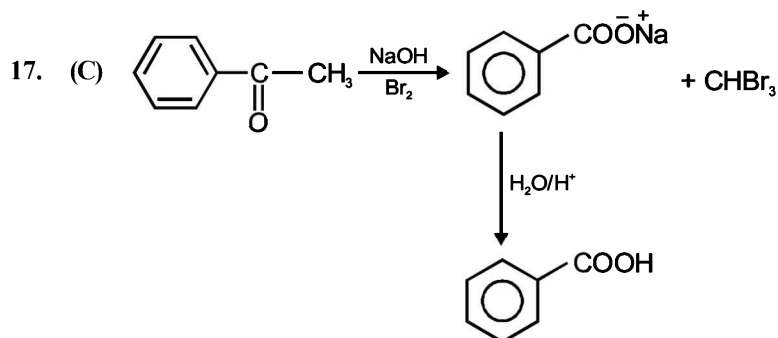
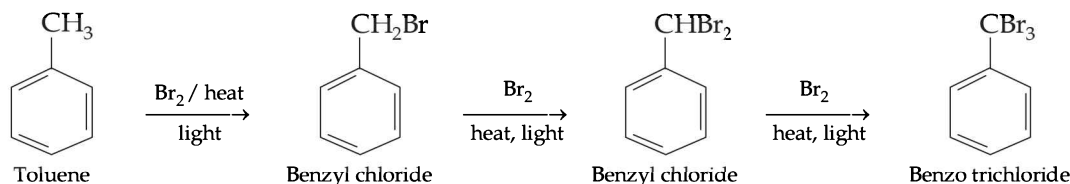

18. (D) Perkin condensation of benzaldehyde with  $(\text{CH}_3\text{CO})_2\text{O}/\text{CH}_3\text{COOK}$  yields cis and trans form of cinnamic acid.

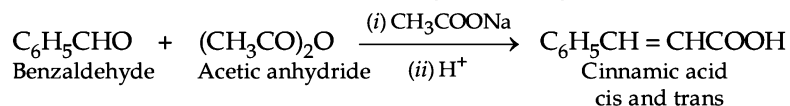

## Paper - 2

1. (C) As T increase, V.P. increases  
 $\Delta T_f = K_f \times m$

$$273 - T'_f = 2 \times \frac{34.5 \times 1000}{46 \times 500}$$

$$\therefore T'_f = 270 \text{ K}$$

2. (B)  $\text{Zn(s)} + \text{Cu}^{2+}_{(\text{aq})} \rightarrow \text{Zn}^{2+}_{(\text{aq})} + \text{Cu(s)}$

$$\Delta G = \Delta G^\circ + 2.303 RT \log_{10} Q; Q = \frac{[\text{Zn}^{2+}]}{[\text{Cu}^{2+}]}$$

$$[\Delta G^\circ = -nFE^\circ] = -2 \times F \times 1.1$$

$$\text{Given } [\text{Zn}^{2+}] = 10[\text{Cu}^{2+}]$$

$$\therefore \Delta G = -2F(1.1) + 2.303 RT \log_{10} 10 = 2.303 RT - 2.2F$$

10

## JEE Advanced 2017 Solved Paper

3. (A) At eq.  $\Delta G = 0$   
 $\Delta G^\circ = dp(\Delta V)$   
 $2.9 \text{ kJ mol}^{-1} = (P_2 - 1) \times 2 \times 10^{-6} \text{ m}^3 \text{ mol}^{-1}$   
 or  

$$2.9 \times 10^3 \frac{\text{kg m}^2}{\text{s}^2 \text{ mol}^{-1}} = (P_2 - 1) (2 \times 10^{-6}) \frac{\text{m}^3}{\text{mol}^{-1}}$$

$$(P_2 - 1) = \frac{2.9 \times 10^3 \times 10^6}{2} \frac{\text{kg}}{\text{ms}^2}$$

$$= 1.45 \times 10^9 \frac{\text{kg}}{\text{ms}^2} = 1.45 \times 10^9 \text{ Pa}$$

$$\therefore P_2 = 1.45 \times 10^9 + 1 \text{ Pa}$$

$$= 14500 \times 10^5 + 1 = 14501 \times 10^5 \text{ Pa} = 14501 \text{ Bar}$$
4. (C)  $\text{Fe} + \text{conc. HNO}_3 \rightarrow \text{Fe}_2\text{O}_3$   
 $\text{Cu} + \text{conc. HNO}_3 \rightarrow \text{CuNO}_3 + \text{NO}_2 + \text{H}_2\text{O}$   
 $4\text{Au} + 8\text{NaCN} + \text{O}_2 + 2\text{H}_2\text{O} \rightarrow 4\text{Na}[\text{Au}(\text{CN})_2] + 4\text{NaOH}$   
 $\text{Zn} + \text{NaOH} \rightarrow \text{Na}_2\text{ZnO}_2 + \text{H}_2$
5. (C) Correct order :  
 $\text{H}_3\text{PO}_4 > \text{H}_4\text{P}_2\text{O}_6 > \text{H}_3\text{PO}_3 > \text{H}_3\text{PO}_2$   
 (+5)            (+4)            (+3)            (+1)

6. (C)  
 Step 1 :

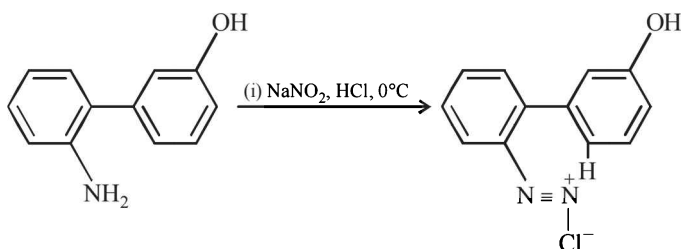

Step 2 :

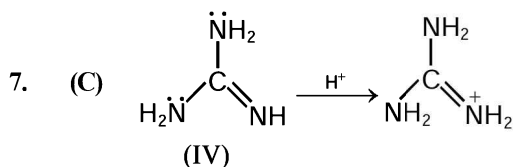
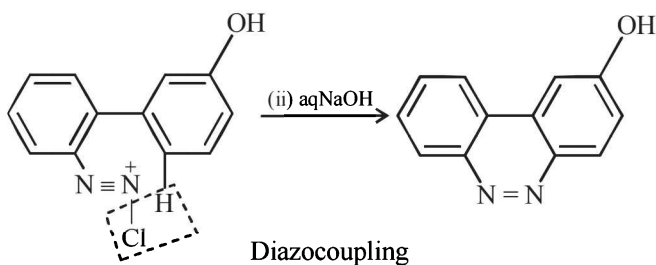

The conjugate acid is stabilized by resonance with two different  $-\text{NH}_2$  group. Hence electron density increases on N of  $=\text{NH}$

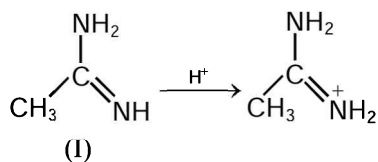

The conjugate acid is stabilized by resonance with one  $-\text{NH}_2$  group. Hence as compared to IV lesser increase of electron density on N of  $=\text{NH}$

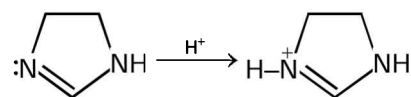

(II)

Lone pair is not involvd in aromaticity. Hence more available

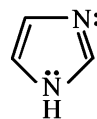

(III)

Lone pair is involved in aromatic sextet. Hence not available.

Hence the correct order of basic strength is

IV > I > II > III

8. (A, B)

(A) As adsorption is spontaneous,  $\Delta G$  for the process is  $-ve$ . Adsorption is accompanied by decrease in randomness. Therefore  $\Delta S$  and  $T\Delta S$  for the process is also negative. As  $\Delta S$  for the process is  $-ve$  and the process is spontaneous,  $\Delta H$  for the process has to be  $-ve$  i.e, enthalpy of the system decreases.

(B) Under a given set of conditions of temperature and pressure the easily liquefiable gases e.g.  $\text{C}_2\text{H}_6$ ,  $\text{NH}_3$  and  $\text{HCl}$  are adsorbed more than the gases like  $\text{N}_2$ ,  $\text{H}_2$  and  $\text{CO}$ . The ease with which a gas can be liquefied is determined by its critical temperature.

Critical temperature is the minimum temperature above which a gas can be liquified. This implies that gases with high critical temperature values can be easily liquified as compared to gases with low critical temperature value.

9. (A, B, D)

10. (A, B) The Arrhenius equation is

$$k = A e^{-E_a/RT}$$

where A = Pre-exponential factor

A is not directly related with temperature and activation energy.

$$\text{Where } A = \frac{Z}{(\text{Frequency factor})} \times \frac{P}{(\text{Steric factor})}$$

Hence we can say the  $E_a$  is independent of steric factor

$$P = \frac{K_{\text{actual}}}{K_{\text{theoretical}}}$$

So,  $A_{\text{actual}} > A_{\text{theoretical}}$

11. (A, B, C)

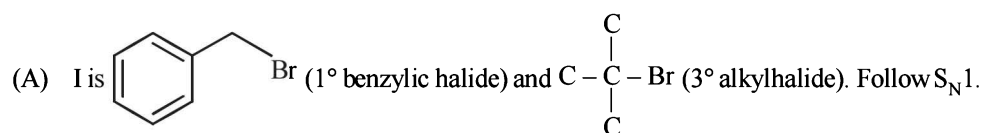

(B) I and II follow  $\text{S}_{\text{N}}2$  also, as both are 1° halide.

(C) Compound (IV) undergoes inversion of configuration due to presence of chiral carbon atom.

12. (A, B, D)

(A) Structure of  $\text{Al}_2(\text{CH}_3)_6$

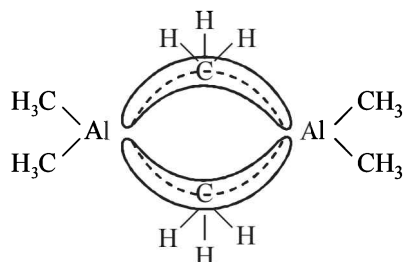

3C-2e<sup>-</sup> Bond

(B) Structure of  $\text{B}_2\text{H}_6$

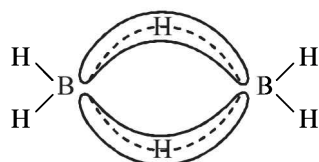

3C-2e<sup>-</sup> Bond

(C) Structure of  $\text{Al}_2\text{Cl}_6$

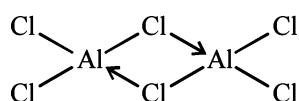

(D)  $\text{BCl}_3$  is stronger Lewis acid as the bond formed with the base will involve 2p orbital overlap which is stronger than 3p orbital overlap in the case of  $\text{AlCl}_3$ .

13. (A, D)  $\text{NO} \Rightarrow$  Neutral

$\text{B}_2\text{O}_3 \Rightarrow$  Acidic

$\text{CrO} \Rightarrow$  Basic

All other oxides are amphoteric

14. (A, B)

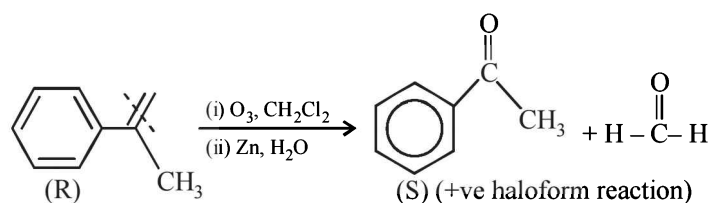
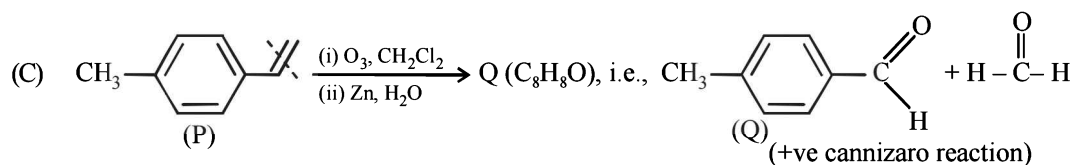



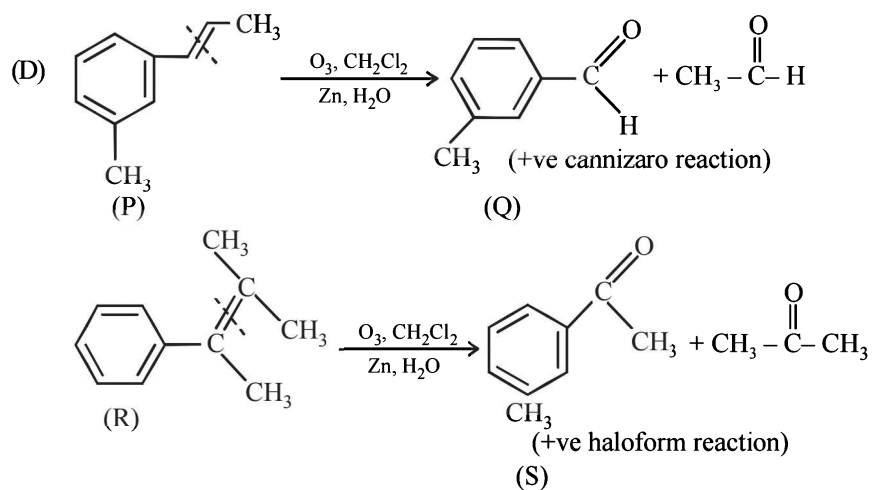

15. (C) &amp; 16. (B)

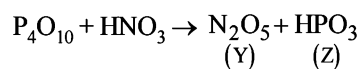
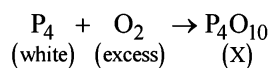
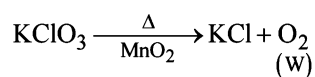

17. (A) &amp; 18. (C)

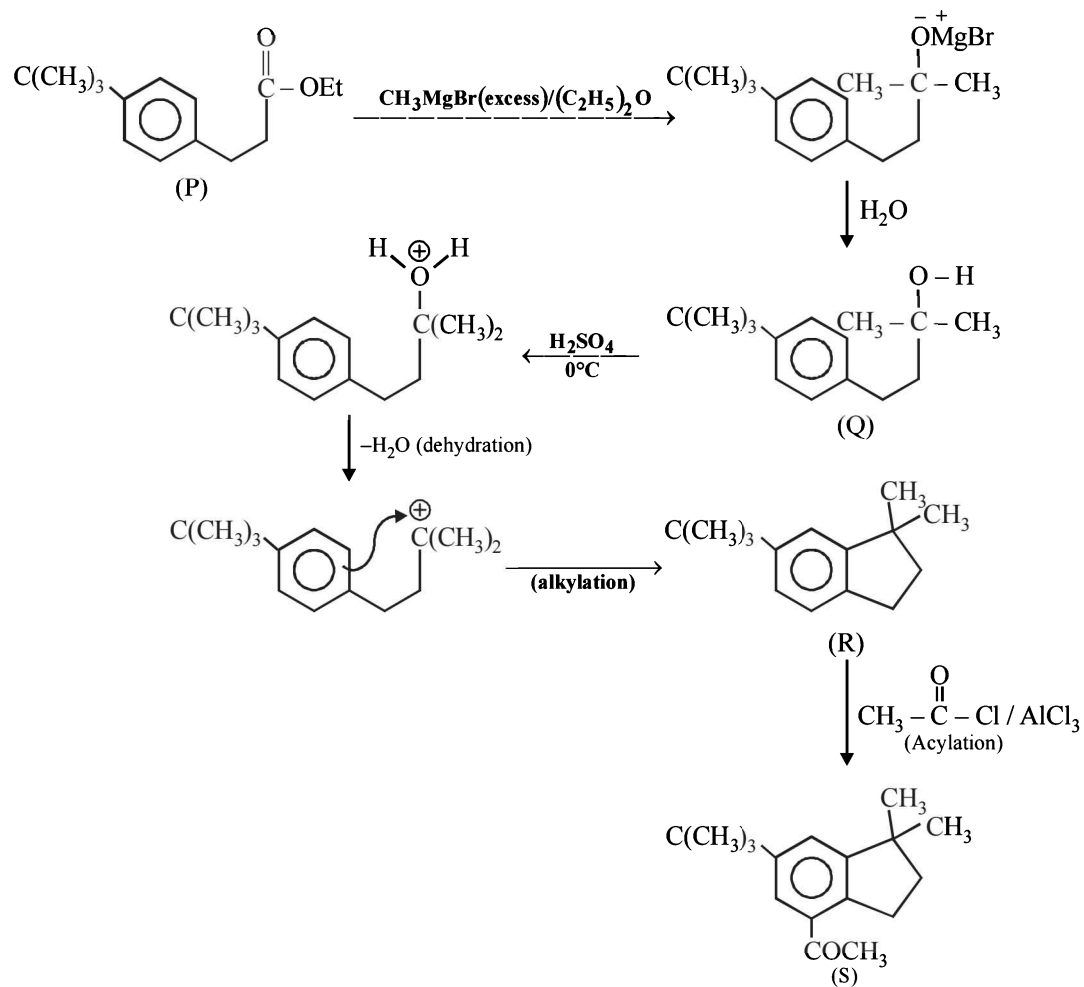

# JEE MAIN 2017 - CHEMISTRY

Held On : 2<sup>nd</sup> April, 2017

1. Which of the following compounds will form significant amount of meta product during mono-nitration reaction ?

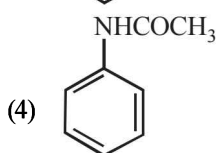
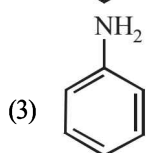
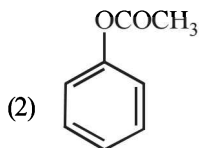
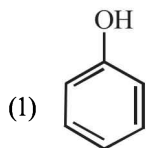

2.  $\Delta U$  is equal to

- (1) Isochoric work (2) Isobaric work  
(3) Adiabatic work (4) Isothermal work

3. The increasing order of the reactivity of the following halides for the  $S_N1$  reaction is

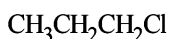

(I)

(II)

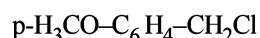

(III)

- (1) (III) < (II) < (I) (2) (II) < (I) < (III)  
(3) (I) < (III) < (II) (4) (II) < (III) < (I)

4. The radius of the second Bohr orbit for hydrogen atom is :

(Plank's const.  $h = 6.6262 \times 10^{-34}$  Js ; mass of electron =  $9.1091 \times 10^{-31}$  kg ; charge of electron  $e = 1.60210 \times 10^{-19}$  C ; permittivity of vacuum  $\epsilon_0 = 8.854185 \times 10^{-12}$  kg<sup>-1</sup> m<sup>-3</sup> A<sup>2</sup>)

- (1) 1.65Å (2) 4.76Å  
(3) 0.529Å (4) 2.12Å

5.  $\text{pK}_a$  of a weak acid (HA) and  $\text{pK}_b$  of a weak base (BOH) are 3.2 and 3.4, respectively. The pH of their salt (AB) solution is

- (1) 7.2 (2) 6.9  
(3) 7.0 (4) 1.0

6. The formation of which of the following polymers involves hydrolysis reaction?

- (1) Nylon 6 (2) Bakelite  
(3) Nylon 6, 6 (4) Terylene

7. The most abundant elements by mass in the body of a healthy human adult are :

Oxygen (61.4%) ; Carbon (22.9%), Hydrogen (10.0%) ; and Nitrogen (2.6%). The weight which a 75 kg person would gain if all  $^1\text{H}$  atoms are replaced by  $^2\text{H}$  atoms is

- (1) 15 kg (2) 37.5 kg  
(3) 7.5 kg (4) 10 kg

8. Which of the following, upon treatment with tert-BuONa followed by addition of bromine water, fails to decolourize the colour of bromine?

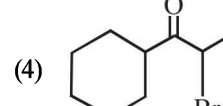
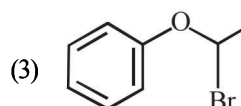
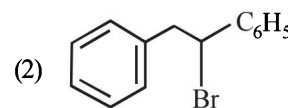
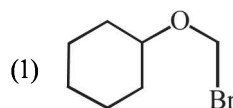

9. In the following reactions, ZnO is respectively acting as a/an:

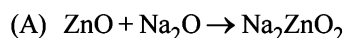

- (1) base and acid (2) base and base  
(3) acid and acid (4) acid and base

10. Both lithium and magnesium display several similar properties due to the diagonal relationship; however, the one which is incorrect is :

- (1) Both form basic carbonates  
(2) Both form soluble bicarbonates  
(3) Both form nitrides  
(4) Nitrates of both Li and Mg yield  $\text{NO}_2$  and  $\text{O}_2$  on heating

11. 3-Methyl-pent-2-ene on reaction with HBr in presence of peroxide forms an addition product. The number of possible stereoisomers for the product is :

- (1) Six (2) Zero  
(3) Two (4) Four

12. A metal crystallises in a face centred cubic structure. If the edge length of its unit cell is 'a', the closest approach between two atoms in metallic crystal will be :

- (1) 2a (2)  $2\sqrt{2}a$

- (3)  $\sqrt{2}a$  (4)  $\frac{a}{\sqrt{2}}$

13. Two reactions  $R_1$  and  $R_2$  have identical pre-exponential factors. Activation energy of  $R_1$  exceeds that of  $R_2$  by 10 kJ mol<sup>-1</sup>. If  $k_1$  and  $k_2$  are rate constants for reactions  $R_1$  and  $R_2$  respectively at 300 K, then  $\ln(k_2/k_1)$  is equal to :

( $R = 8.314$  J mol<sup>-1</sup>K<sup>-1</sup>)

- (1) 8 (2) 12  
(3) 6 (4) 4

14. The correct sequence of reagents for the following conversion will be :

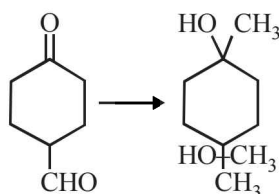

- (1)  $[\text{Ag}(\text{NH}_3)_2]^+ \text{OH}^-$ ,  $\text{H}^+/\text{CH}_3\text{OH}$ ,  $\text{CH}_3\text{MgBr}$   
 (2)  $\text{CH}_3\text{MgBr}$ ,  $\text{H}^+/\text{CH}_3\text{OH}$ ,  $[\text{Ag}(\text{NH}_3)_2]^+ \text{OH}^-$   
 (3)  $\text{CH}_3\text{MgBr}$ ,  $[\text{Ag}(\text{NH}_3)_2]^+ \text{OH}^-$ ,  $\text{H}^+/\text{CH}_3\text{OH}$   
 (4)  $[\text{Ag}(\text{NH}_3)_2]^+ \text{OH}^-$ ,  $\text{CH}_3\text{MgBr}$ ,  $\text{H}^+/\text{CH}_3\text{OH}$
15. The Tyndall effect is observed only when following conditions are satisfied :

- (a) The diameter of the dispersed particles is much smaller than the wavelength of the light used.  
 (b) The diameter of the dispersed particle is not much smaller than the wavelength of the light used.  
 (c) The refractive indices of the dispersed phase and dispersion medium are almost similar in magnitude.  
 (d) The refractive indices of the dispersed phase and dispersion medium differ greatly in magnitude.

- (1) (a) and (d)                      (2) (b) and (d)  
 (3) (a) and (c)                      (4) (b) and (c)

16. Which of the following compounds will behave as a reducing sugar in an aqueous KOH solution?

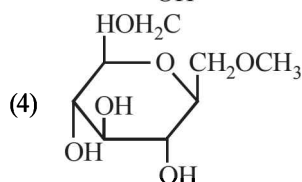
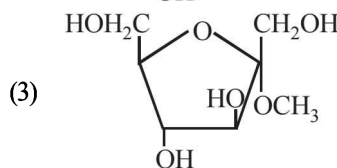
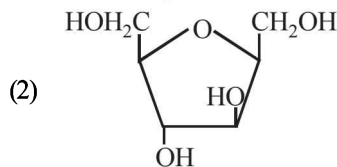
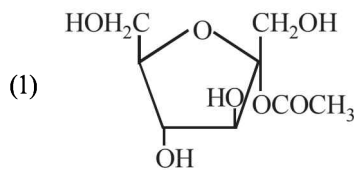

17. Given

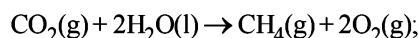
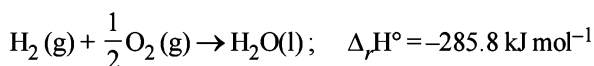
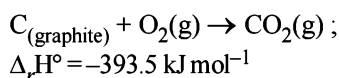

$$\Delta_r H^\circ = +890.3 \text{ kJ mol}^{-1}$$

Based on the above thermochemical equations, the value of  $\Delta_r H^\circ$  at 298 K for the reaction

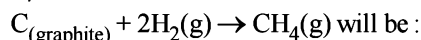

- (1)  $+74.8 \text{ kJ mol}^{-1}$                       (2)  $+144.0 \text{ kJ mol}^{-1}$   
 (3)  $-74.8 \text{ kJ mol}^{-1}$                       (4)  $-144.0 \text{ kJ mol}^{-1}$

18. Which of the following reactions is an example of a redox reaction?

- (1)  $\text{XeF}_4 + \text{O}_2\text{F}_2 \rightarrow \text{XeF}_6 + \text{O}_2$   
 (2)  $\text{XeF}_2 + \text{PF}_5 \rightarrow [\text{XeF}]^+ \text{PF}_6^-$   
 (3)  $\text{XeF}_6 + \text{H}_2\text{O} \rightarrow \text{XeOF}_4 + 2\text{HF}$   
 (4)  $\text{XeF}_6 + 2\text{H}_2\text{O} \rightarrow \text{XeO}_2\text{F}_2 + 4\text{HF}$

19. The products obtained when chlorine gas reacts with cold and dilute aqueous NaOH are :

- (1)  $\text{ClO}^-$  and  $\text{ClO}_3^-$                       (2)  $\text{ClO}_2^-$  and  $\text{ClO}_3^-$   
 (3)  $\text{Cl}^-$  and  $\text{ClO}^-$                       (4)  $\text{Cl}^-$  and  $\text{ClO}_2^-$

20. The major product obtained in the following reaction is :

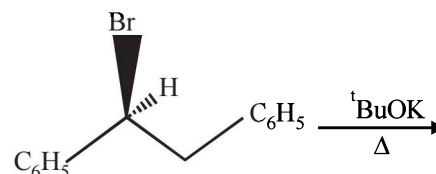

- (1)  $(\pm)\text{C}_6\text{H}_5\text{CH}(\text{O}^t\text{Bu})\text{CH}_2\text{C}_6\text{H}_5$   
 (2)  $\text{C}_6\text{H}_5\text{CH}=\text{CHC}_6\text{H}_5$   
 (3)  $(+)\text{C}_6\text{H}_5\text{CH}(\text{O}^t\text{Bu})\text{CH}_2\text{C}_6\text{H}_5$   
 (4)  $(-)\text{C}_6\text{H}_5\text{CH}(\text{O}^t\text{Bu})\text{CH}_2\text{C}_6\text{H}_5$

21. Sodium salt of an organic acid 'X' produces effervescence with conc.  $\text{H}_2\text{SO}_4$ . 'X' reacts with the acidified aqueous  $\text{CaCl}_2$  solution to give a white precipitate which decolourises acidic solution of  $\text{KMnO}_4$ . 'X' is :

- (1)  $\text{C}_6\text{H}_5\text{COONa}$                       (2)  $\text{HCOONa}$   
 (3)  $\text{CH}_3\text{COONa}$                       (4)  $\text{Na}_2\text{C}_2\text{O}_4$

22. Which of the following species is not paramagnetic ?

- (1)  $\text{NO}$                                       (2)  $\text{CO}$   
 (3)  $\text{O}_2$                                       (4)  $\text{B}_2$

23. The freezing point of benzene decreases by  $0.45^\circ\text{C}$  when 0.2g of acetic acid is added to 20 g of benzene. If acetic acid associates to form a dimer in benzene, percentage association of acetic acid in benzene will be :

$$(K_f \text{ for benzene} = 5.12 \text{ K kg mol}^{-1})$$

- (1) 64.6%                                      (2) 80.4%  
 (3) 74.6%                                      (4) 94.6%

24. Which of the following molecules is least resonance stabilized?

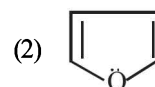
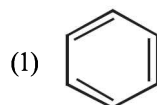

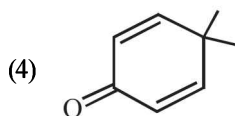
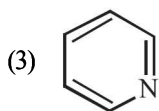

25. On treatment of 100 mL of 0.1 M solution of  $\text{CoCl}_3 \cdot 6\text{H}_2\text{O}$  with excess  $\text{AgNO}_3$ ;  $1.2 \times 10^{22}$  ions are precipitated. The complex is :

- (1)  $[\text{Co}(\text{H}_2\text{O})_4\text{Cl}_2]\text{Cl} \cdot 2\text{H}_2\text{O}$
- (2)  $[\text{Co}(\text{H}_2\text{O})_3\text{Cl}_3] \cdot 3\text{H}_2\text{O}$
- (3)  $[\text{Co}(\text{H}_2\text{O})_6]\text{Cl}_3$
- (4)  $[\text{Co}(\text{H}_2\text{O})_5\text{Cl}]\text{Cl}_2 \cdot \text{H}_2\text{O}$

26. The major product obtained in the following reaction is :

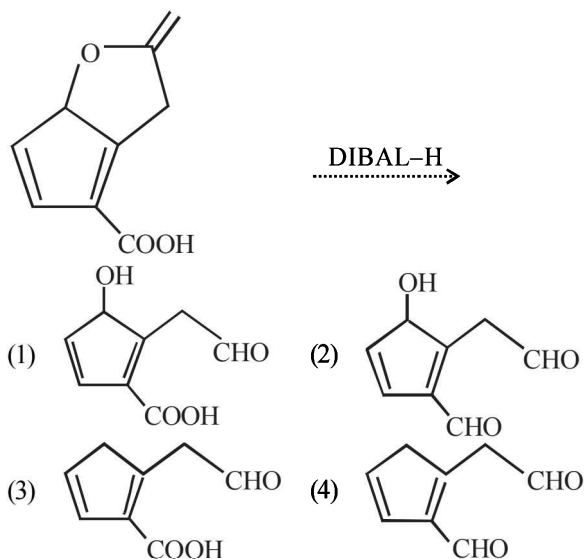

27. A water sample has ppm level concentration of following anions

$$\text{F}^- = 10; \text{SO}_4^{2-} = 100; \text{NO}_3^- = 50$$

the anion/anions that make/makes the water sample unsuitable for drinking is/are :

- (1) only  $\text{NO}_3^-$
- (2) both  $\text{SO}_4^{2-}$  and  $\text{NO}_3^-$
- (3) only  $\text{F}^-$
- (4) only  $\text{SO}_4^{2-}$

28. 1 gram of a carbonate ( $\text{M}_2\text{CO}_3$ ) on treatment with excess  $\text{HCl}$  produces 0.01186 mole of  $\text{CO}_2$ . The molar mass of  $\text{M}_2\text{CO}_3$  in  $\text{g mol}^{-1}$  is :

- (1) 1186
- (2) 84.3
- (3) 118.6
- (4) 11.86

29. Given

$$E^\circ_{\text{Cl}_2/\text{Cl}^-} = 1.36\text{V}, E^\circ_{\text{Cr}^{3+}/\text{Cr}} = -0.74\text{V},$$

$$E^\circ_{\text{Cr}_2\text{O}_7^{2-}/\text{Cr}^{3+}} = 1.33\text{V}, E^\circ_{\text{MnO}_4^-/\text{Mn}^{2+}} = 1.51\text{V}.$$

Among the following, the strongest reducing agent is

- (1)  $\text{Cr}$
- (2)  $\text{Mn}^{2+}$
- (3)  $\text{Cr}^{3+}$
- (4)  $\text{Cl}^-$

30. The group having isoelectronic species is :

- (1)  $\text{O}^{2-}, \text{F}^-, \text{Na}^+, \text{Mg}^{2+}$
- (2)  $\text{O}^-, \text{F}^-, \text{Na}, \text{Mg}^+$
- (3)  $\text{O}^{2-}, \text{F}^-, \text{Na}, \text{Mg}^{2+}$
- (4)  $\text{O}^-, \text{F}^-, \text{Na}^+, \text{Mg}^{2+}$

# SOLUTIONS

1. (3) Nitration takes place in presence of concentrated  $\text{HNO}_3$  + concentrated  $\text{H}_2\text{SO}_4$ .

In strongly acidic nitration medium, the amine is converted into anilinium ion ( $-\text{NH}_3^+$ ); substitution is thus controlled not by  $-\text{NH}_2$  group but by  $-\text{NH}_3^+$  group which, because of its positive charge, directs the entering group to the meta-position instead of ortho, and para.

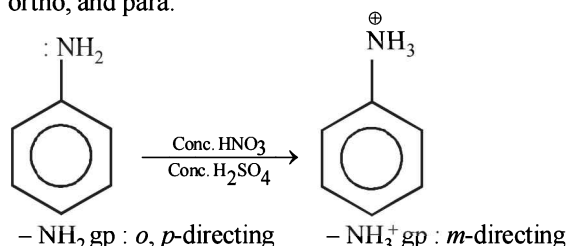

2. (3) From 1<sup>st</sup> law of thermodynamics

$$\Delta U = q + w$$

For adiabatic process :

$$q = 0$$

$$\therefore \Delta U = w$$

3. (2) Since  $\text{S}_{\text{N}}1$  reactions involve the formation of carbocation as intermediate in the rate determining step, more is the stability of carbocation higher will be the reactivity of alkyl halides towards  $\text{S}_{\text{N}}1$  route.

Since stability of carbocation follows order.

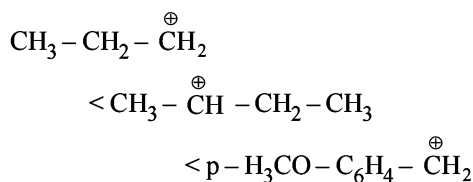

Hence correct order is II < I < III

4. (4) Radius of  $n^{\text{th}}$  Bohr orbit in H-atom

$$= 0.53 n^2 \text{ \AA}$$

$$\text{Radius of II Bohr orbit} = 0.53 \times (2)^2$$

$$= 2.12 \text{ \AA}$$

5. (2) Given

$$\text{p}K_{\text{a}}(\text{HA}) = 3.2$$

$$\text{p}K_{\text{b}}(\text{BOH}) = 3.4$$

The salt (AB) given is a salt of weak acid and weak base. Hence the pH can be calculated by the formula

$$\therefore \text{pH} = 7 + \frac{1}{2} \text{p}K_{\text{a}} - \frac{1}{2} \text{p}K_{\text{b}}$$

$$= 7 + \frac{1}{2}(3.2) - \frac{1}{2}(3.4)$$

$$= 6.9$$

6. (1) Formation of Nylon-6 involves hydrolysis of caprolactam, (its monomer) in initial state.

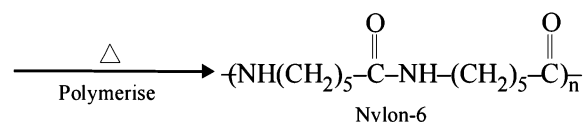
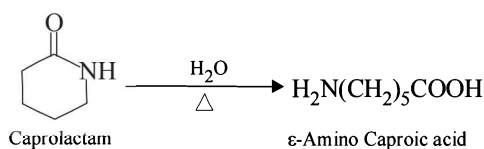

7. (3) Percentage (by mass) of elements given in the body of a healthy human adult is :-

Oxygen = 61.4%, Carbon = 22.9%,

Hydrogen = 10.0% and Nitrogen = 2.6%

$\therefore$  Total weight of person = 75 kg

$\therefore$  Mass due to  $^1\text{H}$  is =  $75 \times \frac{10}{100} = 7.5 \text{ kg}$

If  $^1\text{H}$  atoms are replaced by  $^2\text{H}$  atoms.

Mass gain by person would be = 7.5 kg

8. (1)

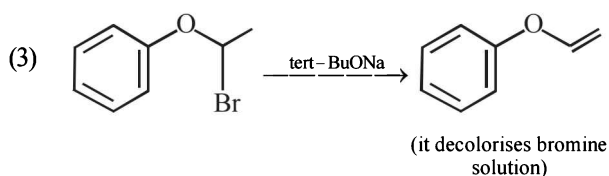
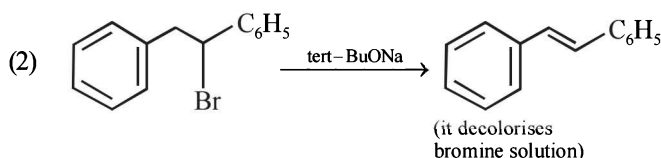
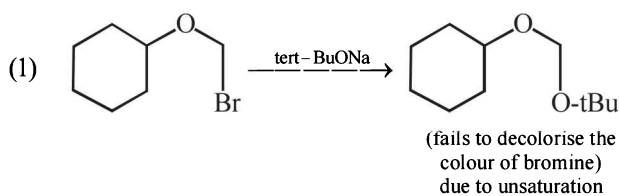

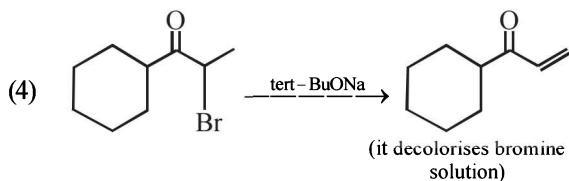

Products formed in option (2), (3) & (4) decolorises bromine solution due to presence of double bond.

9. (4) Although ZnO is an amphoteric oxide but in given reaction.

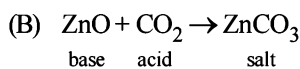
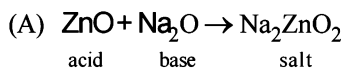

10. (1) Mg can form basic carbonate like  $3\text{MgCO}_3 \cdot \text{Mg}(\text{OH})_2 \cdot 3\text{H}_2\text{O}$

While Li can form only carbonate ( $\text{Li}_2\text{CO}_3$ ) not basic carbonate.

11. (4) If two chirality centres are created as a result of an addition reaction four stereoisomers can be obtained as products.

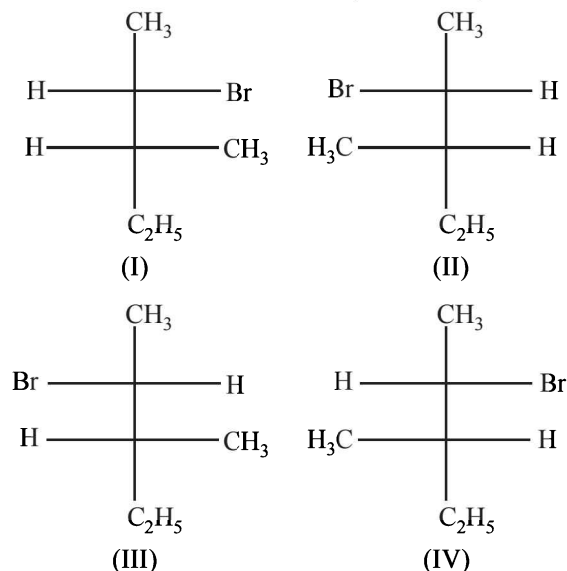
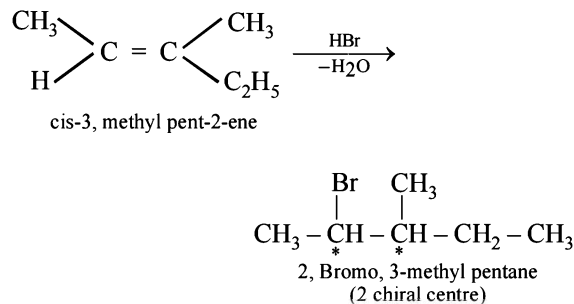

12. (4) For a FCC unit cell

$$r = \frac{\sqrt{2} a}{4}$$

$$\therefore \text{closest distance } (2r) = \frac{\sqrt{2} a}{4} = \frac{a}{\sqrt{2}}$$

13. (4) From arrhenius equation,

$$k = A.e^{\frac{-E_a}{RT}}$$

so,  $k_1 = A.e^{-E_{a1}/RT}$  .....(1)

$$k_2 = A.e^{-E_{a2}/RT}$$
 .....(2)

On dividing equation (2)/(1)  $\Rightarrow \frac{k_2}{k_1} = e^{\frac{(E_{a1}-E_{a2})}{RT}}$

$$\ln\left(\frac{k_2}{k_1}\right) = \frac{E_{a1} - E_{a2}}{RT} = \frac{10,000}{8.314 \times 300} = 4$$

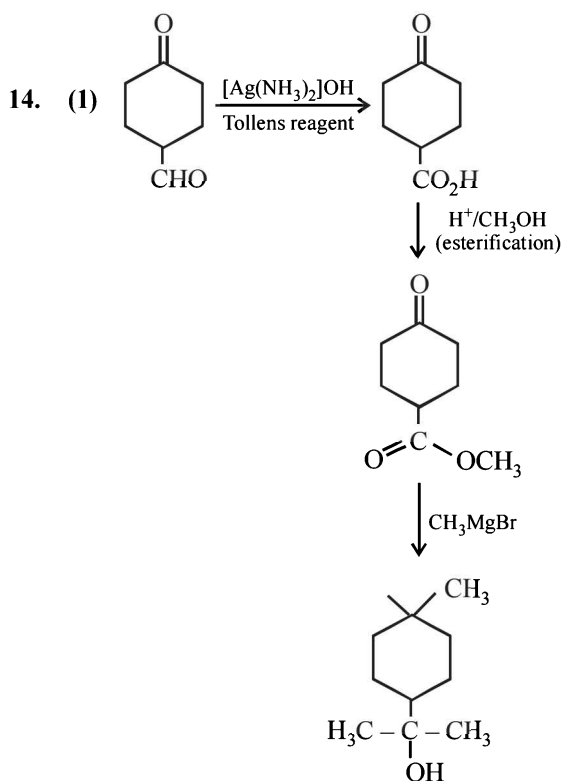

15. (2)

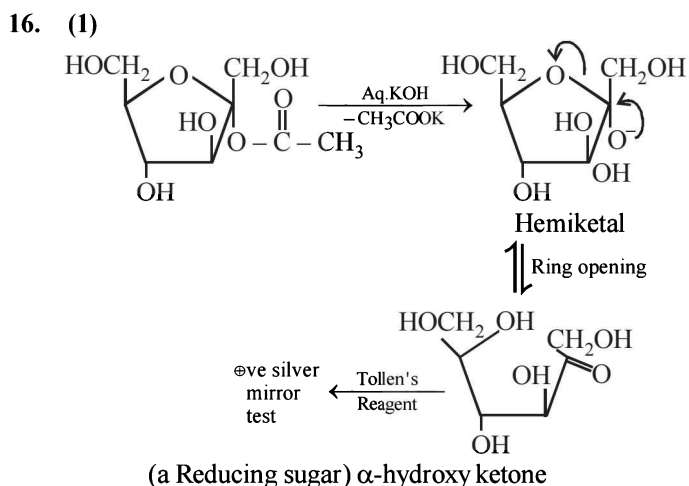

17. (3) Given

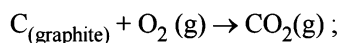
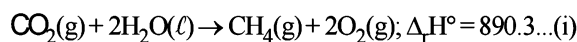

$$\Delta_f H^\circ = -393.5 \text{ kJ mol}^{-1} \dots (\text{ii})$$

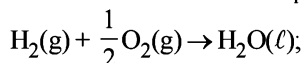

$$\Delta_f H^\circ = -285.8 \text{ kJ mol}^{-1} \dots (\text{iii})$$

$$\Delta_r H^\circ = \sum (\Delta_f H^\circ)_{\text{products}} - \sum (\Delta_f H^\circ)_{\text{reactants}}$$

$$890.3 = [1 \times (\Delta_f H^\circ)_{\text{CH}_4} + 2 \times 0] - [1 \times (-393.5) + 2(-285.8)]$$

$$(\Delta_f H^\circ)_{\text{CH}_4} = 890.3 - 965.1 = -74.8 \text{ kJ/mol}$$

18. (1) In the reaction

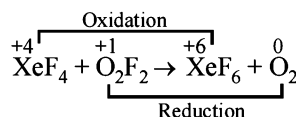
19. (3)  $\text{Cl}_2 + \text{NaOH} \rightarrow \text{NaCl} + \text{NaClO} + \text{H}_2\text{O}$ [cold  
and dilute]

20. (2) Elimination reaction is highly favoured if

(a) Bulkier base is used

(b) Higher temperature is used

Hence in given reaction bimolecular elimination reaction provides major product.

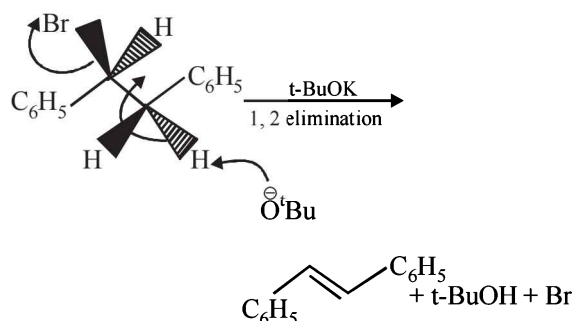
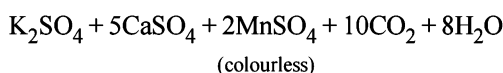
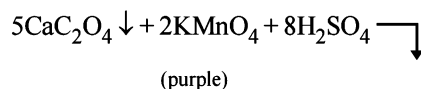
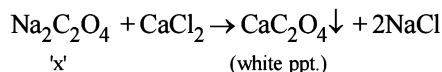
21. (4)  $\text{Na}_2\text{C}_2\text{O}_4 + \text{H}_2\text{SO}_4 \rightarrow \text{Na}_2\text{SO}_4 + \text{CO}\uparrow + \text{CO}_2\uparrow + \text{H}_2\text{O}$   
'x' (conc.)

22. (2)

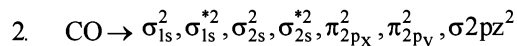
1.  $\text{NO} \rightarrow$  one unpaired electron is present in  $\pi^*$  molecular orbitals hence paramagnetic.

no unpaired electron hence diamagnetic.

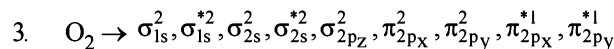

two unpaired electrons hence paramagnetic.

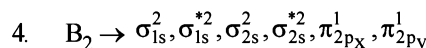
 $\text{B}_2$  contains two unpaired electrons hence paramagnetic

23. (4) In benzene

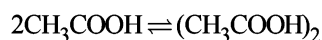

$$1 - \alpha \quad \alpha/2$$

$$i = 1 - \alpha + \alpha/2 = 1 - \alpha/2$$

Here  $\alpha$  is degree of association

$$\Delta T_f = iK_f m$$

$$0.45 = \left(1 - \frac{\alpha}{2}\right) (5.12) \frac{(0.2)}{\frac{60}{20}} \frac{1}{1000}$$

$$1 - \frac{\alpha}{2} = 0.527$$

$$\alpha = 0.945$$

% degree of association = 94.6%

24. (4) is nonaromatic and hence least resonance

stabilized whereas other three are aromatic.

25. (4) Moles of complex =  $\frac{\text{Molarity} \times \text{Volume (ml)}}{1000}$ 

$$= \frac{100 \times 0.1}{1000} = 0.01 \text{ mole}$$

Moles of ions precipitated with excess of

$$\text{AgNO}_3 = \frac{1.2 \times 10^{22}}{6.02 \times 10^{23}} = 0.02 \text{ moles}$$

$$0.01 \times n = 0.02$$

$$\therefore n = 2$$

It means  $2\text{Cl}^-$  ions present in ionization sphere $\therefore$  complex is  $[\text{Co}(\text{H}_2\text{O})_5\text{Cl}]\text{Cl}_2 \cdot \text{H}_2\text{O}$ 

26. (2) DIBAL-H is an electrophilic reducing agent. It reduces both ester and carboxylic group into an aldehyde at

low temperature.

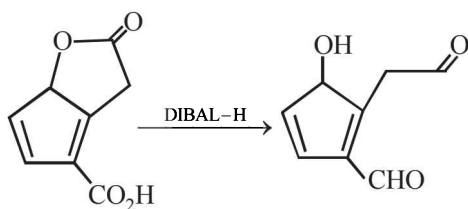

27. (3) Above 2 ppm concentration of F<sup>-</sup> in drinking water cause brown mottling of teeth.

28. (2) Given chemical eq<sup>n</sup>

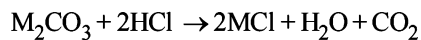

$$1\text{ gm} \qquad \qquad \qquad 0.01186 \text{ mol}$$

from the balanced chemical eq<sup>n</sup>.

$$nM_2CO_3 = nCO_2$$

$$\frac{1}{M_2CO_3} = 0.01186$$

$$\therefore M_2CO_3 = \frac{1}{0.01186}$$

$$\Rightarrow M = 84.3 \text{ gm/mol}$$

29. (1)  $E^\circ_{MnO_4^-/Mn^{+2}} = 1.51V$

$$E^\circ_{Cl_2/Cl^-} = 1.36V$$

$$E^\circ_{Cr_2O_7^{2-}/Cr^{+3}} = 1.33V$$

$$E^\circ_{Cr^{+3}/Cr} = -0.74$$

Since Cr<sup>+3</sup> is having least reducing potential, so Cr is the best reducing agent.

30. (1) Isoelectronic species have same no. of electrons.

ions	O <sup>-2</sup>	F <sup>-</sup>	Na <sup>+</sup>	Mg <sup>+2</sup>
------	-----------------	----------------	-----------------	------------------

	8+2	9+1	11-1	12-2
--	-----	-----	------	------

No. of e <sup>-</sup> =	10	10	10	10
-------------------------	----	----	----	----

therefore O<sup>2-</sup>, F<sup>-</sup>, Na<sup>+</sup>, Mg<sup>+2</sup> are isoelectronic



## CHAPTER

## 1

## Some Basic Concepts of Chemistry

## Section-A

## JEE Advanced/ IIT-JEE

## A Fill in the Blanks

- The modern atomic mass unit is based on .....  
(1980)
- The total number of electrons present in 18 ml of water is .....  
(1980)
- 3 g of a salt of molecular weight 30 is dissolved in 250 g of water. The molality of the solution is .....  
(1983 - 1 Mark)
- The weight of  $1 \times 10^{22}$  molecules of  $\text{CuSO}_4 \cdot 5\text{H}_2\text{O}$  is .....  
(1991 - 1 Mark)
- The compound  $\text{YBa}_2\text{Cu}_3\text{O}_7$ , which shows superconductivity, has copper in oxidation state....., assume that the rare earth element yttrium is in its usual +3 oxidation state.  
(1994 - 1 Mark)
- 2.76 g of silver carbonate on being strongly heated yields a residue weighing ..... (1979)  
(a) 2.16 g (b) 2.48 g  
(c) 2.32 g (d) 2.64 g
- M is molecular weight of  $\text{KMnO}_4$ . The equivalent weight of  $\text{KMnO}_4$  when it is converted into  $\text{K}_2\text{MnO}_4$  is ..... (1980)  
(a) M (b)  $M/3$   
(c)  $M/5$  (d)  $M/7$
- If 0.50 mole of  $\text{BaCl}_2$  is mixed with 0.20 mol of  $\text{Na}_3\text{PO}_4$ , the maximum number of moles of  $\text{Ba}_3(\text{PO}_4)_2$  that can be formed is ..... (1981 - 1 Mark)  
(a) 0.70 (b) 0.50  
(c) 0.20 (d) 0.10
- One mole of  $\text{N}_2\text{H}_4$  loses ten moles of electrons to form a new compound Y. Assuming that all the nitrogen appears in the new compound, what is the oxidation state of nitrogen in Y? (There is no change in the oxidation state of hydrogen).  
(1981 - 1 Mark)  
(a) -1 (b) -3  
(c) +3 (d) +5

## C MCQs with One Correct Answer

- 27 g of Al will react completely with how many grams of oxygen? (1978)  
(a) 8 g (b) 16 g  
(c) 32 g (d) 24 g
- A compound was found to contain nitrogen and oxygen in the ratio 28 gm and 80 gm respectively. The formula of compound is (1978)  
(a) NO (b)  $\text{N}_2\text{O}_3$   
(c)  $\text{N}_2\text{O}_5$  (d)  $\text{N}_2\text{O}_4$
- The largest number of molecules is in (1979)  
(a) 36 g of water  
(b) 28 g of carbon monoxide  
(c) 46 g of ethyl alcohol  
(d) 54 g of nitrogen pentoxide
- The total number of electrons in one molecule of carbon dioxide is (1979)  
(a) 22 (b) 44  
(c) 66 (d) 88
- A gaseous mixture contains oxygen and nitrogen in the ratio of 1 : 4 by weight. Therefore the ratio of their number of molecules is (1979)  
(a) 1 : 4 (b) 1 : 8  
(c) 7 : 32 (d) 3 : 16
- The oxidation number of carbon in  $\text{CH}_2\text{O}$  is (1982 - 1 Mark)  
(a) -2 (b) +2  
(c) 0 (d) +4
- A molal solution is one that contains one mole of a solute in: (1986 - 1 Mark)  
(a) 1000 g of the solvent  
(b) one litre of the solvent  
(c) one litre of the solution  
(d) 22.4 litres of the solution
- The brown ring complex compound is formulated as  $[\text{Fe}(\text{H}_2\text{O})_5(\text{NO})]\text{SO}_4$ . The oxidation state of iron is: (1987 - 1 Mark)  
(a) 1 (b) 2  
(c) 3 (d) 0
- The equivalent weight of  $\text{MnSO}_4$  is half of its molecular weight when it is converted to: (1988 - 1 Mark)  
(a)  $\text{Mn}_2\text{O}_3$  (b)  $\text{MnO}_2$   
(c)  $\text{MnO}_4^-$  (d)  $\text{MnO}_4^{2-}$
- In which mode of expression, the concentration of a solution remains independent of temperature? (1988 - 1 Mark)  
(a) Molarity (b) Normality  
(c) Formality (d) Molality

15. The oxidation number of phosphorus in  $\text{Ba}(\text{H}_2\text{PO}_2)_2$  is :  
(1990 - 1 Mark)
- (a) +3 (b) +2  
(c) +1 (d) -1
16. The oxidation states of the most electronegative element in the products of the reaction,  $\text{BaO}_2$  with dil.  $\text{H}_2\text{SO}_4$  is  
(1991 - 1 Mark)
- (a) 0 and -1 (b) -1 and -2  
(c) -2 and 0 (d) -2 and -1
17. For the redox reaction : (1992 - 1 Mark)
- $$\text{MnO}_4^- + \text{C}_2\text{O}_4^{2-} + \text{H}^+ \rightarrow \text{Mn}^{2+} + \text{CO}_2 + \text{H}_2\text{O}$$
- the correct coefficients of the reactants for the balanced reaction are (1992 - 1 Mark)
- |     | $\text{MnO}_4^-$ | $\text{C}_2\text{O}_4^{2-}$ | $\text{H}^+$ |
|-----|------------------|-----------------------------|--------------|
| (a) | 2                | 5                           | 16           |
| (b) | 16               | 5                           | 2            |
| (c) | 5                | 16                          | 2            |
| (d) | 2                | 16                          | 5            |
18. The normality of 0.3 M phosphorous acid ( $\text{H}_3\text{PO}_3$ ) is,  
(1999 - 2 Marks)
- (a) 0.1 (b) 0.9  
(c) 0.3 (d) 0.6
19. The oxidation number of sulphur in  $\text{S}_8$ ,  $\text{S}_2\text{F}_2$ ,  $\text{H}_2\text{S}$  respectively, are  
(1999 - 2 Marks)
- (a) 0, +1 and -2 (b) +2, +1 and -2  
(c) 0, +1 and +2 (d) -2, +1 and -2
20. Amongst the following identify the species with an atom in +6 oxidation state (2000S)
- (a)  $\text{MnO}_4^-$  (b)  $\text{Cr}(\text{CN})_6^{3-}$   
(c)  $\text{NiF}_6^{2-}$  (d)  $\text{CrO}_2\text{Cl}_2$
21. The reaction,  $3\text{ClO}^-(\text{aq}) \longrightarrow \text{ClO}_3^-(\text{aq}) + 2\text{Cl}^-(\text{aq})$ , is an example of (2001S)
- (a) oxidation reaction  
(b) reduction reaction  
(c) disproportionation reaction  
(d) decomposition reaction
22. An aqueous solution of 6.3 g oxalic acid dihydrate is made up to 250 ml. The volume of 0.1 N NaOH required to completely neutralize 10 ml of this solution is (2001S)
- (a) 40 ml (b) 20 ml  
(c) 10 ml (d) 4 ml
23. In the standardization of  $\text{Na}_2\text{S}_2\text{O}_3$  using  $\text{K}_2\text{Cr}_2\text{O}_7$  by iodometry, the equivalent weight of  $\text{K}_2\text{Cr}_2\text{O}_7$  is (2001S)
- (a) (molecular weight)/2  
(b) (molecular weight)/6  
(c) (molecular weight)/3  
(d) same as molecular weight
24. How many moles of electron weigh one kilogram? (2002S)
- (a)  $6.023 \times 10^{23}$  (b)  $\frac{1}{9.108} \times 10^{31}$
- (c)  $\frac{6.023}{9.108} \times 10^{54}$  (d)  $\frac{1}{9.108 \times 6.023} \times 10^8$
25. Which has maximum number of atoms? (2003S)
- (a) 24g of C (12) (b) 56g of Fe (56)  
(c) 27g of Al (27) (d) 108g of Ag (108)
26. Mixture X = 0.02 mol of  $[\text{Co}(\text{NH}_3)_5\text{SO}_4]\text{Br}$  and 0.02 mol of  $[\text{Co}(\text{NH}_3)_5\text{Br}]\text{SO}_4$  was prepared in 2 litre of solution. (2003S)
- 1 litre of mixture X + excess  $\text{AgNO}_3 \longrightarrow Y$ .
- 1 litre of mixture X + excess  $\text{BaCl}_2 \longrightarrow Z$
- No. of moles of Y and Z are
- (a) 0.01, 0.01 (b) 0.02, 0.01  
(c) 0.01, 0.02 (d) 0.02, 0.02
27. The pair of the compounds in which both the metals are in the highest possible oxidation state is (2004S)
- (a)  $[\text{Fe}(\text{CN})_6]^{3-}$ ,  $[\text{Co}(\text{CN})_6]^{3-}$   
(b)  $\text{CrO}_2\text{Cl}_2$ ,  $\text{MnO}_4^-$   
(c)  $\text{TiO}_3$ ,  $\text{MnO}_2$   
(d)  $[\text{Co}(\text{CN})_6]^{3-}$ ,  $\text{MnO}_3$
28. Consider a titration of potassium dichromate solution with acidified Mohr's salt solution using diphenylamine as indicator. The number of moles of Mohr's salt required per mole of dichromate is (2007)
- (a) 3 (b) 4  
(c) 5 (d) 6

## E Subjective Problems

- What weight of  $\text{AgCl}$  will be precipitated when a solution containing 4.77 g of  $\text{NaCl}$  is added to a solution of 5.77 g of  $\text{AgNO}_3$ ? (1978)
- One gram of an alloy of aluminium and magnesium when treated with excess of dil.  $\text{HCl}$  forms magnesium chloride, aluminium chloride and hydrogen. The evolved hydrogen, collected over mercury at  $0^\circ\text{C}$  has a volume of 1.20 litres at 0.92 atm. pressure. Calculate the composition of the alloy. [ $\text{H} = 1$ ,  $\text{Mg} = 24$ ,  $\text{Al} = 27$ ] (1978)
- Igniting  $\text{MnO}_2$  converts it quantitatively to  $\text{Mn}_3\text{O}_4$ . A sample of pyrolusite is of the following composition :  $\text{MnO}_2$  80%,  $\text{SiO}_2$  and other inert constituents 15%, rest being water. The sample is ignited in air to constant weight. What is the percentage of Mn in the ignited sample? (1978) [ $\text{O} = 16$ ,  $\text{Mn} = 54.9$ ]
- 4.215 g of a metallic carbonate was heated in a hard glass tube and the  $\text{CO}_2$  evolved was found to measure 1336 ml at  $27^\circ\text{C}$  and 700 mm pressure. What is the equivalent weight of the metal? (1979)
- (a) 5.5 g of a mixture of  $\text{FeSO}_4 \cdot 7\text{H}_2\text{O}$  and  $\text{Fe}_2(\text{SO}_4)_3 \cdot 9\text{H}_2\text{O}$  requires 5.4 ml of 0.1 N  $\text{KMnO}_4$  solution for complete oxidation. Calculate the number of gram mole of hydrated ferric sulphate in the mixture.

- (b) The vapour density (hydrogen = 1) of a mixture consisting of  $\text{NO}_2$  and  $\text{N}_2\text{O}_4$  is 38.3 at  $26.7^\circ\text{C}$ . Calculate the number of moles of  $\text{NO}_2$  in 100 g of the mixture. (1979)
6. 5 ml of a gas containing only carbon and hydrogen were mixed with an excess of oxygen (30 ml) and the mixture exploded by means of an electric spark. After the explosion, the volume of the mixed gases remaining was 25 ml. On adding a concentrated solution of potassium hydroxide, the volume further diminished to 15 ml of the residual gas being pure oxygen. All volumes have been reduced to N.T.P. Calculate the molecular formula of the hydrocarbon gas. (1979)
7. In the analysis of 0.500 g sample of feldspar, a mixture of chlorides of sodium and potassium is obtained which weighs 0.1180g. Subsequent treatment of mixed chlorides with silver nitrate gives 0.2451g of silver chloride. What is the percentage of sodium oxide and potassium oxide in feldspar. (1979)
8. A compound contains 28 percent of nitrogen and 72 percent of metal by weight. 3 atoms of metal combine with 2 atoms of N. Find the atomic weight of metal. (1980)
9. (i) A sample of  $\text{MnSO}_4 \cdot 4\text{H}_2\text{O}$  is strongly heated in air. The residue is  $\text{Mn}_3\text{O}_4$ .  
 (ii) The residue is dissolved in 100 ml of 0.1 N  $\text{FeSO}_4$  containing dilute  $\text{H}_2\text{SO}_4$ .  
 (iii) The solution reacts completely with 50 ml of  $\text{KMnO}_4$  solution.  
 (iv) 25 ml of the  $\text{KMnO}_4$  solution used in step (iii) requires 30 ml of 0.1 N  $\text{FeSO}_4$  solution for complete reaction.  
 Find the amount of  $\text{MnSO}_4 \cdot 4\text{H}_2\text{O}$  present in the sample. (1980)
10. (a) One litre of a sample of hard water contains 1 mg of  $\text{CaCl}_2$  and 1 mg of  $\text{MgCl}_2$ . Find the total hardness in terms of parts of  $\text{CaCO}_3$  per  $10^6$  parts of water by weight.  
 (b) A sample of hard water contains 20 mg of  $\text{Ca}^{++}$  ions per litre. How many milli-equivalent of  $\text{Na}_2\text{CO}_3$  would be required to soften 1 litre of the sample?  
 (c) 1 gm of Mg is burnt in a closed vessel which contains 0.5 gm of  $\text{O}_2$ .  
 (i) Which reactant is left in excess?  
 (ii) Find the weight of the excess reactants?  
 (iii) How many milliliters of 0.5 N  $\text{H}_2\text{SO}_4$  will dissolve the residue in the vessel. (1980)
11. A hydrocarbon contains 10.5g of carbon per gram of hydrogen. 1 litre of the vapour of the hydrocarbon at  $127^\circ\text{C}$  and 1 atmosphere pressure weighs 2.8g. Find the molecular formula. (1980)
12. Find (1980)  
 (i) The total number of neutrons and  
 (ii) The total mass of neutron in 7 mg of  $^{14}\text{C}$ .  
 (Assume that mass of neutron = mass of hydrogen atom)
13. A mixture contains NaCl and unknown chloride MCl.  
 (i) 1 g of this is dissolved in water. Excess of acidified  $\text{AgNO}_3$  solution is added to it. 2.567 g of white ppt. is formed.  
 (ii) 1 g of original mixture is heated to  $300^\circ\text{C}$ . Some vapours come out which are absorbed in acidified  $\text{AgNO}_3$  solution, 1.341 g of white precipitate was obtained.  
 Find the molecular weight of unknown chloride. (1980)
14. A 1.00 gm sample of  $\text{H}_2\text{O}_2$  solution containing X per cent  $\text{H}_2\text{O}_2$  by weight requires X ml of a  $\text{KMnO}_4$  solution for complete oxidation under acidic conditions. Calculate the normality of the  $\text{KMnO}_4$  solution. (1981 - 3 Marks)
15. Balance the following equations.  
 (i)  $\text{Cu}_2\text{O} + \text{H}^+ + \text{NO}_3^- \rightarrow \text{Cu}^{2+} + \text{NO} + \text{H}_2\text{O}$  (1981 - 1 Mark)  
 (ii)  $\text{K}_4[\text{Fe}(\text{CN})_6] + \text{H}_2\text{SO}_4 + \text{H}_2\text{O} \rightarrow \text{K}_2\text{SO}_4 + \text{FeSO}_4 + (\text{NH}_4)_2\text{SO}_4 + \text{CO}$  (1981 - 1 Mark)  
 (iii)  $\text{C}_2\text{H}_5\text{OH} + \text{I}_2 + \text{OH}^- \rightarrow \text{CHI}_3 + \text{HCO}_3^- + \text{I}^- + \text{H}_2\text{O}$  (1981 - 1 Mark)
16. Hydroxylamine reduces iron (III) according to the equation:  
 $2\text{NH}_2\text{OH} + 4\text{Fe}^{3+} \rightarrow \text{N}_2\text{O}(\text{g}) \uparrow + \text{H}_2\text{O} + 4\text{Fe}^{2+} + 4\text{H}^+$   
 Iron (II) thus produced is estimated by titration with a standard permanganate solution. The reaction is :  
 $\text{MnO}_4^- + 5\text{Fe}^{2+} + 8\text{H}^+ \rightarrow \text{Mn}^{2+} + 5\text{Fe}^{3+} + 4\text{H}_2\text{O}$   
 A 10 ml. sample of hydroxylamine solution was diluted to 1 litre. 50 ml. of this diluted solution was boiled with an excess of iron (III) solution. The resulting solution required 12 ml. of 0.02 M  $\text{KMnO}_4$  solution for complete oxidation of iron (II). Calculate the weight of hydroxylamine in one litre of the original solution. (H = 1, N = 14, O = 16, K = 39, Mn = 55, Fe = 56) (1982 - 4 Marks)
17. The density of a 3 M sodium thiosulphate solution ( $\text{Na}_2\text{S}_2\text{O}_3$ ) is 1.25 g per ml. Calculate (i) the percentage by weight of sodium thiosulphate, (ii) the mole fraction of sodium thiosulphate and (iii) the molalities of  $\text{Na}^+$  and  $\text{S}_2\text{O}_3^{2-}$  ions. (1983 - 5 Marks)
18. 4.08 g of a mixture of BaO and an unknown carbonate  $\text{MCO}_3$  was heated strongly. The residue weighed 3.64 g. This was dissolved in 100 ml of 1 N HCl. The excess acid required 16 ml of 2.5 N NaOH solution for complete neutralization. Identify the metal M. (1983 - 4 Marks)  
 (At. wt. H = 1, C = 12, O = 16, Cl = 35.5, Ba = 138)

19. Complete and balance the following reactions :

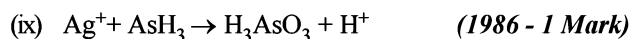
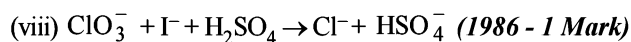
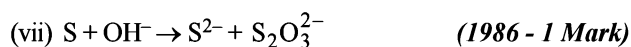
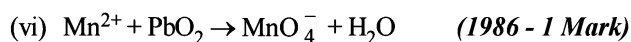
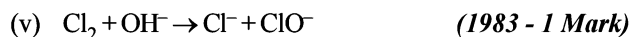
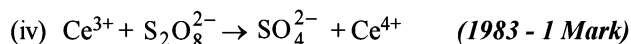
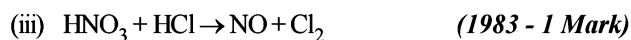
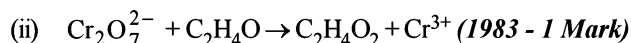

20.  $2.68 \times 10^{-3}$  moles of a solution containing an ion  $A^{n+}$  require  $1.61 \times 10^{-3}$  moles of  $\text{MnO}_4^-$  for the oxidation of  $A^{n+}$  to  $\text{AO}_3^-$  in acid medium. What is the value of  $n$ ?

(1984 - 2 Marks)

21. Five ml of 8N nitric acid, 4.8 ml of 5N hydrochloric acid and a certain volume of 17M sulphuric acid are mixed together and made upto 2litre. Thirty ml. of this acid mixture exactly neutralise 42.9 ml of sodium carbonate solution containing one gram of  $\text{Na}_2\text{CO}_3 \cdot 10\text{H}_2\text{O}$  in 100 ml. of water. Calculate the amount in gram of the sulphate ions in solution.

(1985 - 4 Marks)

22. Arrange the following in increasing oxidation number of iodine.

(1986 - 1 Mark)



23. (i) What is the weight of sodium bromate and molarity of solution necessary to prepare 85.5 ml of 0.672 N solution when the half-cell reaction is

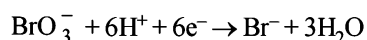

(ii) What would be the weight as well as molarity if the half-cell reaction is :

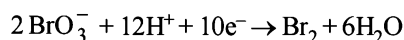

(1987 - 5 Marks)

24. A sugar syrup of weight 214.2 g contains 34.2 g of sugar ( $\text{C}_{12}\text{H}_{22}\text{O}_{11}$ ). Calculate : (i) molal concentration and (ii) mole fraction of sugar in the syrup.

(1988 - 2 Marks)

25. A sample of hydrazine sulphate ( $\text{N}_2\text{H}_6\text{SO}_4$ ) was dissolved in 100 ml. of water, 10 ml of this solution was reacted with excess of ferric chloride solution and warmed to complete the reaction. Ferrous ion formed was estimated and it required 20 ml. of M/50 potassium permanganate solution. Estimate the amount of hydrazine sulphate in one litre of the solution.

(1988 - 3 Marks)

Reaction :

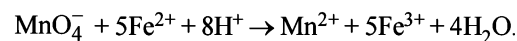
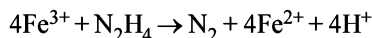

26. An equal volume of a reducing agent is titrated separately with 1M  $\text{KMnO}_4$  in acid neutral and alkaline media. The volumes of  $\text{KMnO}_4$  required are 20 ml. in acid, 33.4 ml. neutral and 100 ml. in alkaline media. Find out the oxidation state of manganese in each reduction product. Give the balanced equations for all the three half reactions. Find out the volume of 1M  $\text{K}_2\text{Cr}_2\text{O}_7$  consumed; if the same volume of the reducing agent is titrated in acid medium. (1989 - 5 Marks)

27. A mixture of  $\text{H}_2\text{C}_2\text{O}_4$  (oxalic acid) and  $\text{NaHC}_2\text{O}_4$  weighing 2.02 g was dissolved in water and solution made upto one litre. Ten millilitres of the solution required 3.0 ml. of 0.1 N sodium hydroxide solution for complete neutralization. In another experiment, 10.0 ml. of the same solution, in hot dilute sulphuric acid medium. require 4.0 ml. of 0.1 N potassium permanganate solution for complete reaction. Calculate the amount of  $\text{H}_2\text{C}_2\text{O}_4$  and  $\text{NaHC}_2\text{O}_4$  in the mixture. (1990 - 5 Marks)

28. A solid mixture (5.0 g) consisting of lead nitrate and sodium nitrate was heated below  $600^\circ\text{C}$  until the weight of the residue was constant. If the loss in weight is 28.0 per cent, find the amount of lead nitrate and sodium nitrate in the mixture.

(1990 - 4 Marks)

29. Calculate the molality of 1 litre solution of 93%  $\text{H}_2\text{SO}_4$  (weight/volume). The density of the solution is 1.84 g/ml.

(1990 - 1 Marks)

30. A solution of 0.2 g of a compound containing  $\text{Cu}^{2+}$  and

$\text{C}_2\text{O}_4^{2-}$  ions on titration with 0.02 M  $\text{KMnO}_4$  in presence of  $\text{H}_2\text{SO}_4$  consumes 22.6 ml. of the oxidant. The resultant solution is neutralized with  $\text{Na}_2\text{CO}_3$ , acidified with dil. acetic acid and treated with excess KI. The liberated iodine requires 11.3 ml of 0.05 M  $\text{Na}_2\text{S}_2\text{O}_3$  solution for complete reduction.

Find out the molar ratio of  $\text{Cu}^{2+}$  to  $\text{C}_2\text{O}_4^{2-}$  in the compound. Write down the balanced redox reactions involved in the above titrations.

(1991 - 5 Marks)

31. A 1.0 g sample of  $\text{Fe}_2\text{O}_3$  solid of 55.2% purity is dissolved in acid and reduced by heating the solution with zinc dust. The resultant solution is cooled and made upto 100.0 ml. An aliquot of 25.0 ml of this solution requires 17.0 ml of 0.0167 M solution of an oxidant for titration. Calculate the number of electrons taken up by the oxidant in the reaction of the above titration.

(1991 - 4 Marks)

32. A 2.0 g sample of a mixture containing sodium carbonate, sodium bicarbonate and sodium sulphate is gently heated till the evolution of  $\text{CO}_2$  ceases. The volume of  $\text{CO}_2$  at 750 mm Hg pressure and at 298 K is measured to be 123.9 ml. A 1.5g of the same sample requires 150 ml. of (M/10) HCl for complete neutralisation. Calculate the % composition of the components of the mixture.

(1992 - 5 Marks)

33. One gram of commercial  $\text{AgNO}_3$  is dissolved in 50 ml. of water. It is treated with 50 ml. of a KI solution. The silver iodide thus precipitated is filtered off. Excess of KI in the filtrate is titrated with (M/10)  $\text{KIO}_3$  solution in presence of 6M HCl till all  $\text{I}^-$  ions are converted into  $\text{ICl}$ . It requires 50 ml. of (M/10)  $\text{KIO}_3$  solution. 20 ml. of the same stock solution of KI requires 30 ml. of (M/10)  $\text{KIO}_3$  under similar conditions. Calculate the percentage of  $\text{AgNO}_3$  in the sample.  
(Reaction :  $\text{KIO}_3 + 2\text{KI} + 6\text{HCl} \rightarrow 3\text{ICl} + 3\text{KCl} + 3\text{H}_2\text{O}$ )  
(1992 - 4 Marks)
34. Upon mixing 45.0 ml. of 0.25 M lead nitrate solution with 25.0 ml of 0.10 M chromic sulphate solution, precipitation of lead sulphate takes place. How many moles of lead sulphate are formed? Also, calculate the molar concentrations of the species left behind in the final solution. Assume that lead sulphate is completely insoluble. (1993 - 3 Marks)
35. The composition of a sample of Wustite is  $\text{Fe}_{0.93}\text{O}_{1.00}$ . What percentage of the iron is present in the form of Fe (III)? (1994 - 2 Marks)
36.  $8.0575 \times 10^{-2}$  kg of Glauber's salt is dissolved in water to obtain  $1 \text{ dm}^3$  of a solution of density  $1077.2 \text{ kg m}^{-3}$ . Calculate the molarity, molality and mole fraction of  $\text{Na}_2\text{SO}_4$  in the solution. (1994 - 3 Marks)
37. A 3.00 g sample containing  $\text{Fe}_3\text{O}_4$ ,  $\text{Fe}_2\text{O}_3$  and an inert impure substance, is treated with excess of KI solution in presence of dilute  $\text{H}_2\text{SO}_4$ . The entire iron is converted into  $\text{Fe}^{2+}$  along with the liberation of iodine. The resulting solution is diluted to 100 ml. A 20 ml of the diluted solution requires 11.0 ml of 0.5 M  $\text{Na}_2\text{S}_2\text{O}_3$  solution to reduce the iodine present. A 50 ml of the diluted solution, after complete extraction of the iodine requires 12.80 ml of 0.25 M  $\text{KMnO}_4$  solution in dilute  $\text{H}_2\text{SO}_4$  medium for the oxidation of  $\text{Fe}^{2+}$ . Calculate the percentages of  $\text{Fe}_2\text{O}_3$  and  $\text{Fe}_3\text{O}_4$  in the original sample. (1996 - 5 Marks)
38. An aqueous solution containing 0.10 g  $\text{KIO}_3$  (formula weight = 214.0) was treated with an excess of KI solution. The solution was acidified with HCl. The liberated  $\text{I}_2$  consumed 45.0 mL of thiosulphate solution to decolourise the blue starch-iodine complex. Calculate the molarity of the sodium thiosulphate solution. (1998 - 5 Marks)
39. How many millilitres of 0.5 M  $\text{H}_2\text{SO}_4$  are needed to dissolve 0.5 g of copper(II) carbonate? (1999 - 3 Marks)
40. A plant virus is found to consist of uniform cylindrical particles of 150 Å in diameter and 5000 Å long. The specific volume of the virus is  $0.75 \text{ cm}^3/\text{g}$ . If the virus is considered to be a single particle, find its molar mass. (1999 - 3 Marks)
41. Hydrogen peroxide solution (20 ml) reacts quantitatively with a solution of  $\text{KMnO}_4$  (20 ml) acidified with dilute  $\text{H}_2\text{SO}_4$ . The same volume of the  $\text{KMnO}_4$  solution is just decolourised by 10 ml of  $\text{MnSO}_4$  in neutral medium simultaneously forming a dark brown precipitate of hydrated  $\text{MnO}_2$ . The brown precipitate is dissolved in 10 ml of 0.2 M sodium oxalate under boiling condition in the presence of dilute  $\text{H}_2\text{SO}_4$ . Write the balanced equations involved in the reactions and calculate the molarity of  $\text{H}_2\text{O}_2$ . (2001 - 5 Marks)
42. Calculate the molarity of water if its density is  $1000 \text{ kg/m}^3$ . (2003 - 2 Marks)

## H Assertion & Reason Type Questions

1. Read the following statement and explanation and answer as per the options given below :

**STATEMENT(S) :** In the titration of  $\text{Na}_2\text{CO}_3$  with HCl using methyl orange indicator, the volume required at the equivalence point is twice that of the acid required using phenolphthalein indicator.

**EXPLANATION(E) :** Two moles of HCl are required for the complete neutralization of one mole of  $\text{Na}_2\text{CO}_3$ .

(1991 - 2 Marks)

- (a) Both S and E are true, and E is the correct explanation of S.  
(b) Both S and E are true, but E is not the correct explanation of S.  
(c) S is true but E is false.  
(d) S is false but E is true.

## I Integer Value Correct Type

1. A student performs a titration with different burettes and finds titre values of 25.2 mL, 25.25 mL, and 25.0 mL. The number of significant figures in the average titre value is (2010)
2. Silver (atomic weight =  $108 \text{ g mol}^{-1}$ ) has a density of  $10.5 \text{ cm}^{-3}$ . The number of silver atoms on a surface of area  $10^{-12} \text{ m}^2$  can be expressed in scientific notation as  $y \times 10^x$ . The value of x is : (2010)
3. The difference in the oxidation numbers of the two types of sulphur atoms in  $\text{Na}_2\text{S}_4\text{O}_6$  is (2011)
4. If the value of Avogadro number is  $6.023 \times 10^{23} \text{ mol}^{-1}$  and the value of Boltzmann constant is  $1.380 \times 10^{-23} \text{ J K}^{-1}$ , then the number of significant digits in the calculated value of the universal gas constant is (JEE Adv. 2014)

## Section-B JEE Main / AIEEE

- In a compound C, H and N atoms are present in 9 : 1 : 3.5 by weight. Molecular weight of compound is 108. Molecular formula of compound is [2002]  
(a)  $C_2H_6N_2$  (b)  $C_3H_4N$  (c)  $C_6H_8N_2$  (d)  $C_9H_{12}N_3$ .
- With increase of temperature, which of these changes? [2002]  
(a) molality (b) weight fraction of solute  
(c) molarity (d) mole fraction.
- Number of atoms in 558.5 gram Fe (at. wt. of Fe = 55.85 g  $mol^{-1}$ ) is [2002]  
(a) twice that in 60 g carbon  
(b)  $6.023 \times 10^{22}$   
(c) half that in 8 g He  
(d)  $558.5 \times 6.023 \times 10^{23}$
- What volume of hydrogen gas, at 273 K and 1 atm. pressure will be consumed in obtaining 21.6 g of elemental boron (atomic mass = 10.8) from the reduction of boron trichloride by hydrogen ? [2003]  
(a) 67.2L (b) 44.8L (c) 22.4L (d) 89.6L
- 25ml of a solution of barium hydroxide on titration with a 0.1 molar solution of hydrochloric acid gave a litre value of 35ml. The molarity of barium hydroxide solution was [2003]  
(a) 0.14 (b) 0.28 (c) 0.35 (d) 0.07
- $6.02 \times 10^{20}$  molecules of urea are present in 100 ml of its solution. The concentration of urea solution is [2004]  
(a) 0.02 M (b) 0.01 M (c) 0.001 M (d) 0.1 M  
(Avogadro constant,  $N_A = 6.02 \times 10^{23} mol^{-1}$ )
- To neutralise completely 20 mL of 0.1 M aqueous solution of phosphorous acid ( $H_3PO_3$ ), the value of 0.1 M aqueous KOH solution required is [2004]  
(a) 40mL (b) 20mL (c) 10mL (d) 60mL
- The ammonia evolved from the treatment of 0.30 g of an organic compound for the estimation of nitrogen was passed in 100 mL of 0.1 M sulphuric acid. The excess of acid required 20 mL of 0.5 M sodium hydroxide solution for complete neutralization. The organic compound is [2004]  
(a) urea (b) benzamide  
(c) acetamide (d) thiourea
- Two solutions of a substance (non electrolyte) are mixed in the following manner. 480 ml of 1.5 M first solution + 520 ml of 1.2 M second solution. What is the molarity of the final mixture? [2005]  
(a) 2.70 M (b) 1.344 M (c) 1.50 M (d) 1.20 M
- If we consider that 1/6, in place of 1/12, mass of carbon atom is taken to be the relative atomic mass unit, the mass of one mole of the substance will [2005]  
(a) be a function of the molecular mass of the substance  
(b) remain unchanged  
(c) increase two fold  
(d) decrease twice
- How many moles of magnesium phosphate,  $Mg_3(PO_4)_2$  will contain 0.25 mole of oxygen atoms? [2006]  
(a)  $1.25 \times 10^{-2}$  (b)  $2.5 \times 10^{-2}$   
(c) 0.02 (d)  $3.125 \times 10^{-2}$
- Density of a 2.05M solution of acetic acid in water is 1.02 g/mL. The molality of the solution is [2006]  
(a) 2.28 mol  $kg^{-1}$  (b) 0.44 mol  $kg^{-1}$   
(c) 1.14 mol  $kg^{-1}$  (d) 3.28 mol  $kg^{-1}$
- The density (in g  $mL^{-1}$ ) of a 3.60 M sulphuric acid solution that is 29%  $H_2SO_4$  (molar mass = 98 g  $mol^{-1}$ ) by mass will be [2007]  
(a) 1.45 (b) 1.64  
(c) 1.88 (d) 1.22
- In the reaction, [2007]  
 $2Al(s) + 6HCl(aq) \rightarrow 2Al^{3+}(aq) + 6Cl^{-}(aq) + 3H_2(g)$   
(a) 11.2 L  $H_2(g)$  at STP is produced for every mole HCl(aq) consumed  
(b) 6 L HCl(aq) is consumed for every 3 L  $H_2(g)$  produced  
(c) 33.6 L  $H_2(g)$  is produced regardless of temperature and pressure for every mole Al that reacts  
(d) 67.2  $H_2(g)$  at STP is produced for every mole Al that reacts.
- Consider the following reaction :  
 $xMnO_4^{-} + yC_2O_4^{2-} + zH^{+} \rightarrow xMn^{2+} + 2yCO_2 + \frac{z}{2}H_2O$   
The value's of x, y and z in the reaction are, respectively : [JEE M 2013]  
(a) 5, 2 and 16  
(b) 2, 5 and 8  
(c) 2, 5 and 16  
(d) 5, 2 and 8
- A gaseous hydrocarbon gives upon combustion 0.72 g of water and 3.08 g of  $CO_2$ . The empirical formula of the hydrocarbon is : [JEE M 2013]  
(a)  $C_2H_4$  (b)  $C_3H_4$  (c)  $C_6H_5$  (d)  $C_7H_8$
- Experimentally it was found that a metal oxide has formula  $M_{0.98}O$ . Metal M, present as  $M^{2+}$  and  $M^{3+}$  in its oxide. Fraction of the metal which exists as  $M^{3+}$  would be : [JEE M 2013]  
(a) 7.01% (b) 4.08% (c) 6.05% (d) 5.08%

## CHAPTER

## 2

## Structure of Atom

## Section-A JEE Advanced/ IIT-JEE

## A Fill in the Blanks

- The mass of a hydrogen atom is ..... kg.  
(1982 - 1 Mark)
- Isotopes of an element differ in the number of ..... in their nuclei.  
(1982 - 1 Mark)
- When there are two electrons in the same orbital, they have ..... spins.  
(1982 - 1 Mark)
- Elements of the same mass number but of different atomic numbers are known as .....
- The uncertainty principle and the concept of wave nature of matter were proposed by ..... and ..... respectively. (Heisenberg, Schrodinger, Maxwell, de Broglie)  
(1988 - 1 Mark)
- The light radiations with discrete quantities of energy are called .....
- Wave functions of electrons in atoms and molecules are called .....
- The  $2p_x$ ,  $2p_y$  and  $2p_z$  orbitals of atom have identical shapes but differ in their .....
- The outermost electronic configuration of Cr is .....

## B True / False

- The outer electronic configuration of the ground state chromium atom is  $3d^4 4s^2$ .  
(1982 - 1 Mark)
- Gamma rays are electromagnetic radiations of wavelengths of  $10^{-6}$  cm to  $10^{-5}$  cm.  
(1983 - 1 Mark)
- The energy of the electron in the  $3d$ -orbital is less than that in the  $4s$ -orbital in the hydrogen atom.  
(1983 - 1 Mark)
- The electron density in the  $XY$  plane in  $3d_{x^2 - y^2}$  orbital is zero.  
(1986 - 1 Mark)
- In a given electric field,  $\beta$ -particles are deflected more than  $\alpha$ -particles in spite of  $\alpha$ -particles having larger charge.  
(1993 - 1 Mark)

## C MCQs with One Correct Answer

- The number of neutrons in dipositive zinc ion with mass number 70 is  
(1979)  
(a) 34 (b) 36  
(c) 38 (d) 40
- Rutherford's experiment on scattering of  $\alpha$ -particles showed for the first time that the atom has  
(1981 - 1 Mark)  
(a) electrons (b) protons  
(c) nucleus (d) neutrons
- Any  $p$ -orbital can accommodate upto  
(1983 - 1 Mark)  
(a) four electrons  
(b) six electrons  
(c) two electrons with parallel spins  
(d) two electrons with opposite spins
- The principal quantum number of an atom is related to the  
(1983 - 1 Mark)  
(a) size of the orbital  
(b) spin angular momentum  
(c) orbital angular momentum  
(d) orientation of the orbital in space
- Rutherford's scattering experiment is related to the size of the  
(1983 - 1 Mark)  
(a) nucleus (b) atom  
(c) electron (d) neutron
- The increasing order (lowest first) for the values of  $e/m$  (charge/mass) for electron ( $e$ ), proton ( $p$ ), neutron ( $n$ ) and alpha particle ( $\alpha$ ) is :  
(1984 - 1 Mark)  
(a)  $e, p, n, \alpha$  (b)  $n, p, e, \alpha$   
(c)  $n, p, \alpha, e$  (d)  $n, \alpha, p, e$
- Correct set of four quantum numbers for the valence (outermost) electron of rubidium ( $Z=37$ ) is :  
(1984 - 1 Mark)  
(a)  $5, 0, 0, +\frac{1}{2}$  (b)  $5, 1, 0, +\frac{1}{2}$   
(c)  $5, 1, 1, +\frac{1}{2}$  (d)  $6, 0, 0, +\frac{1}{2}$
- Which electronic level would allow the hydrogen atom to absorb a photon but not to emit a photon?  
(1984 - 1 Mark)  
(a)  $3s$  (b)  $2p$   
(c)  $2s$  (d)  $1s$

9. Bohr model can explain : (1985 - 1 Mark)  
 (a) the spectrum of hydrogen atom only  
 (b) spectrum of an atom or ion containing one electron only  
 (c) the spectrum of hydrogen molecule  
 (d) the solar spectrum
10. The radius of an atomic nucleus is of the order of : (1985 - 1 Mark)  
 (a)  $10^{-10}$  cm (b)  $10^{-13}$  cm  
 (c)  $10^{-15}$  cm (d)  $10^{-8}$  cm
11. Electromagnetic radiation with maximum wavelength is : (1985 - 1 Mark)  
 (a) ultraviolet (b) radiowave  
 (c) X-ray (d) infrared
12. Rutherford's alpha particle scattering experiment eventually led to the conclusion that : (1986 - 1 Mark)  
 (a) mass and energy are related  
 (b) electrons occupy space around the nucleus  
 (c) neutrons are buried deep in the nucleus  
 (d) the point of impact with matter can be precisely determined.
13. Which one of the following sets of quantum numbers represents an impossible arrangement? (1986 - 1 Mark)
- |     | $n$ | $l$ | $m_l$ | $m_s$          |
|-----|-----|-----|-------|----------------|
| (a) | 3   | 2   | -2    | $\frac{1}{2}$  |
| (b) | 4   | 0   | 0     | $\frac{1}{2}$  |
| (c) | 3   | 2   | -3    | $\frac{1}{2}$  |
| (d) | 5   | 3   | 0     | $-\frac{1}{2}$ |
14. The ratio of the energy of a photon of 2000Å wavelength radiation to that of 4000Å radiation is : (1986 - 1 Mark)  
 (a)  $\frac{1}{4}$  (b) 4  
 (c)  $\frac{1}{2}$  (d) 2
15. The triad of nuclei that is isotonic is (1988 - 1 Mark)  
 (a)  ${}^{14}_6\text{C}$ ,  ${}^{15}_7\text{N}$ ,  ${}^{17}_9\text{F}$  (b)  ${}^{12}_6\text{C}$ ,  ${}^{14}_7\text{N}$ ,  ${}^{19}_9\text{F}$   
 (c)  ${}^{14}_6\text{C}$ ,  ${}^{14}_7\text{N}$ ,  ${}^{17}_9\text{F}$  (d)  ${}^{14}_6\text{C}$ ,  ${}^{14}_7\text{N}$ ,  ${}^{19}_9\text{F}$
16. The wavelength of a spectral line for an electronic transition is inversely related to : (1988 - 1 Mark)  
 (a) the number of electrons undergoing the transition  
 (b) the nuclear charge of the atom  
 (c) the difference in the energy of the energy levels involved in the transition  
 (d) the velocity of the electron undergoing the transition.
17. The orbital diagram in which the Aufbau principle is violated is : (1988 - 1 Mark)
- |     | 2s                   | 2p   |
|-----|----------------------|--|
| (a) | $\uparrow\downarrow$ | $\uparrow\downarrow$ $\uparrow$ $\square$  |
| (b) | $\uparrow$           | $\uparrow\downarrow$ $\uparrow$ $\uparrow$ |
| (c) | $\uparrow\downarrow$ | $\uparrow$ $\uparrow$ $\uparrow$           |
- (d)  $\uparrow\downarrow$   $\uparrow\downarrow$   $\uparrow$   $\uparrow$
18. The outermost electronic configuration of the most electronegative element is (1988 - 1 Mark)  
 (a)  $ns^2 np^3$  (b)  $ns^2 np^4$   
 (c)  $ns^2 np^5$  (d)  $ns^2 np^6$
19. The correct ground state electronic configuration of chromium atom is : (1989 - 1 Mark)  
 (a)  $[\text{Ar}] 3d^5 4s^1$  (b)  $[\text{Ar}] 3d^4 4s^2$   
 (c)  $[\text{Ar}] 3d^6 4s^0$  (d)  $[\text{Ar}] 4d^5 4s^1$
20. The correct set of quantum numbers for the unpaired electron of chlorine atom is : (1989 - 1 Mark)
- |     | $n$ | $l$ | $m$ |
|-----|-----|-----|-----|
| (a) | 2   | 1   | 0   |
| (b) | 2   | 1   | 1   |
| (c) | 3   | 1   | 1   |
| (d) | 3   | 0   | 0   |
21. Which of the following does not characterise X-rays? (1992 - 1 Mark)  
 (a) The radiation can ionise gases  
 (b) It causes ZnS to fluorescence  
 (c) Deflected by electric and magnetic fields  
 (d) Have wavelengths shorter than ultraviolet rays
22. Which of the following relates to photons both as wave motion and as a stream of particles? (1992 - 1 Mark)  
 (a) Inference (b)  $E = mc^2$   
 (c) Diffraction (d)  $E = hv$
23. A 3p orbital has : (1995S)  
 (a) two non spherical nodes  
 (b) two spherical nodes  
 (c) one spherical & one non spherical node  
 (d) one spherical and two non spherical nodes
24. The orbital angular momentum of an electron in 2s orbital is : (1996 - 1 Mark)  
 (a)  $+\frac{1}{2} \cdot \frac{h}{2\pi}$  (b) Zero  
 (c)  $\frac{h}{2\pi}$  (d)  $\sqrt{2} \cdot \frac{h}{2\pi}$
25. For a d-electron, the orbital angular momentum is (1997 - 1 Mark)  
 (a)  $\sqrt{6}(h/2\pi)$  (b)  $\sqrt{2}(h/2\pi)$   
 (c)  $(h/2\pi)$  (d)  $2(h/2\pi)$
26. The electrons, identified by quantum numbers  $n$  and  $l$ , (i)  $n=4, l=1$ , (ii)  $n=4, l=0$ , (iii)  $n=3, l=2$ , and (iv)  $n=3, l=1$  can be placed in order of increasing energy, from the lowest to highest, as (1999 - 2 Marks)  
 (a) (iv) < (ii) < (iii) < (i) (b) (ii) < (iv) < (i) < (iii)  
 (c) (i) < (iii) < (ii) < (iv) (d) (iii) < (i) < (iv) < (ii)



27. The number of nodal planes in a  $p_x$  orbital is (2000S)  
 (a) one (b) two  
 (c) three (d) zero
28. The electronic configuration of an element is  $1s^2, 2s^2 2p^6, 3s^2 3p^6 3d^5, 4s^1$ . This represents its (2000S)  
 (a) excited state (b) ground state  
 (c) cationic form (d) anionic form
29. The wavelength associated with a golf ball weighing 200 g and moving at a speed of 5 m/h is of the order (2001S)  
 (a)  $10^{-10}$  m (b)  $10^{-20}$  m  
 (c)  $10^{-30}$  m (d)  $10^{-40}$  m
30. The quantum numbers  $+1/2$  and  $-1/2$  for the electron spin represent (2001S)  
 (a) rotation of the electron in clockwise and anticlockwise direction respectively  
 (b) rotation of the electron in anticlockwise and clockwise direction respectively  
 (c) magnetic moment of the electron pointing up and down respectively  
 (d) two quantum mechanical spin states which have no classical analogue
31. Rutherford's experiment, which established the nuclear model of the atom, used a beam of (2002S)  
 (a)  $\beta$ -particles, which impinged on a metal foil and got absorbed  
 (b)  $\gamma$ -rays, which impinged on a metal foil and ejected electrons  
 (c) helium atoms, which impinged on a metal foil and got scattered  
 (d) helium nuclei, which impinged on a metal foil and got scattered
32. If the nitrogen atom has electronic configuration  $1s^7$ , it would have energy lower than that of the normal ground state configuration  $1s^2 2s^2 2p^3$ , because the electrons would be closer to the nucleus. Yet  $1s^7$  is not observed because it violates. (2002S)  
 (a) Heisenberg uncertainty principle  
 (b) Hund's rule  
 (c) Pauli exclusion principle  
 (d) Bohr postulate of stationary orbits
33. The radius of which of the following orbit is same as that of the first Bohr's orbit of hydrogen atom? (2004S)  
 (a)  $\text{He}^+ (n=2)$  (b)  $\text{Li}^{2+} (n=2)$   
 (c)  $\text{Li}^{2+} (n=3)$  (d)  $\text{Be}^{3+} (n=2)$
34. The number of radial nodes of  $3s$  and  $2p$  orbitals are respectively (2005S)  
 (a) 2, 0 (b) 0, 2  
 (c) 1, 2 (d) 2, 1
35. Given that the abundances of isotopes  $^{54}\text{Fe}$ ,  $^{56}\text{Fe}$  and  $^{57}\text{Fe}$  are 5%, 90% and 5%, respectively, the atomic mass of Fe is (2009S)  
 (a) 55.85 (b) 55.95  
 (c) 55.75 (d) 56.05
36. The kinetic energy of an electron in the second Bohr orbit of a hydrogen atom is [ $a_0$  is Bohr radius] : (2012)  
 (a)  $\frac{h^2}{4\pi^2 m a_0^2}$  (b)  $\frac{h^2}{16\pi^2 m a_0^2}$   
 (c)  $\frac{h^2}{32\pi^2 m a_0^2}$  (d)  $\frac{h^2}{64\pi^2 m a_0^2}$
37. P is the probability of finding the  $1s$  electron of hydrogen atom in a spherical shell of infinitesimal thickness,  $dr$ , at a distance  $r$  from the nucleus. The volume of this shell is  $4\pi r^2 dr$ . The qualitative sketch of the dependence of P on  $r$  is (JEE Adv. 2016)

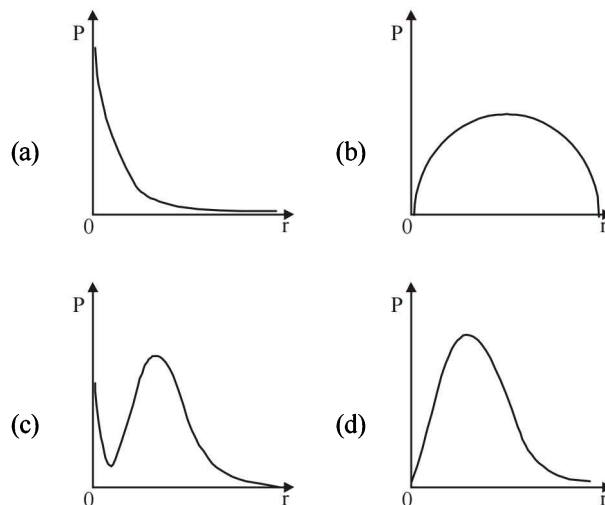

### D MCQs with One or More Than One Correct

1. An isotone of  $^{76}_{32}\text{Ge}$  is : (1984 - 1 Mark)  
 (a)  $^{77}_{32}\text{Ge}$  (b)  $^{77}_{33}\text{As}$   
 (c)  $^{77}_{34}\text{Se}$  (d)  $^{78}_{34}\text{Se}$
2. Many elements have non-integral atomic masses because : (1984 - 1 Mark)  
 (a) they have isotopes  
 (b) their isotopes have non-integral masses  
 (c) their isotopes have different masses  
 (d) the constituents, neutrons, protons and electrons, combine to give fractional masses
3. When alpha particles are sent through a thin metal foil, most of them go straight through the foil because : (1984 - 1 Mark)  
 (a) alpha particles are much heavier than electrons  
 (b) alpha particles are positively charged  
 (c) most part of the atom is empty space  
 (d) alpha particles move with high velocity

4. The sum of the number of neutrons and proton in the isotope of hydrogen is : (1986 - 1 Mark)  
 (a) 6 (b) 2  
 (c) 4 (d) 3
5. The energy of an electron in the first Bohr orbit of H atom is  $-13.6$  eV. The possible energy value(s) of the excited state(s) for electrons in Bohr orbits of hydrogen is (are) (1998 - 2 Marks)  
 (a)  $-3.4$  eV (b)  $-4.2$  eV  
 (c)  $-6.8$  eV (d)  $-1.5$  eV
6. Which of the following statement(s) is (are) correct? (1998 - 2 Marks)  
 (a) The electronic configuration of Cr is  $[\text{Ar}] 3d^5 4s^1$ . (Atomic Number of Cr = 24)  
 (b) The magnetic quantum number may have a negative value.  
 (c) In silver atom, 23 electrons have a spin of one type and 24 of the opposite type. (Atomic Number of Ag = 47)  
 (d) The oxidation state of nitrogen in  $\text{HN}_3$  is  $-3$ .
7. Decrease in atomic number is observed during (1998 - 2 Marks)  
 (a) alpha emission (b) beta emission  
 (c) positron emission (d) electron capture.
8. Ground state electronic configuration of nitrogen atom can be represented by (1999 - 3 Marks)  
 (a)  $\uparrow\downarrow \uparrow\downarrow \uparrow \uparrow \uparrow$  (b)  $\uparrow\downarrow \uparrow\downarrow \uparrow \downarrow \uparrow$   
 (c)  $\uparrow\downarrow \uparrow\downarrow \uparrow \downarrow \downarrow$  (d)  $\uparrow\downarrow \uparrow\downarrow \downarrow \downarrow \downarrow$
5. Give reasons why the ground state outermost electronic configuration of silicon is : (1985 - 2 Marks)  
 $3s \quad 3p \quad 3s \quad 3p$   
 $\boxed{\uparrow\downarrow} \quad \boxed{\uparrow\uparrow} \quad \text{and not} \quad \boxed{\uparrow\downarrow} \quad \boxed{\uparrow\downarrow}$
6. What is the maximum number of electrons that may be present in all the atomic orbitals with principal quantum number 3 and azimuthal quantum number 2? (1985 - 2 Marks)
7. According to Bohr's theory, the electronic energy of hydrogen atom in the  $n^{\text{th}}$  Bohr's orbit is given by  

$$E_n = \frac{-21.76 \times 10^{-19}}{n^2} \text{ J. Calculate the longest wavelength of light that will be needed to remove an electron from the third Bohr orbit of the He}^+ \text{ ion. (1990 - 3 Marks)}$$
8. Estimate the difference in energy between 1st and 2nd Bohr orbit for a hydrogen atom. At what minimum atomic number, a transition from  $n = 2$  to  $n = 1$  energy level would result in the emission of X-rays with  $\lambda = 3.0 \times 10^{-8} \text{ m}$ ? Which hydrogen atom-like species does this atomic number correspond to? (1993 - 5 Marks)
9. What transition in the hydrogen spectrum would have the same wavelength as the Balmer transition  $n = 4$  to  $n = 2$  of  $\text{He}^+$  spectrum? (1993 - 3 Marks)
10. Find out the number of waves made by a Bohr electron in one complete revolution in its 3rd orbit. (1994 - 3 Marks)
11. Iodine molecule dissociates into atoms after absorbing light of  $4500 \text{ \AA}$ . If one quantum of radiation is absorbed by each molecule, calculate the kinetic energy of iodine atoms. (Bond energy of  $\text{I}_2 = 240 \text{ kJ mol}^{-1}$ ) (1995 - 2 Marks)

## E Subjective Problems

1. Naturally occurring boron consists of two isotopes whose atomic weights are 10.01 and 11.01. The atomic weight of natural boron is 10.81. Calculate the percentage of each isotope in natural boron. (1978)
2. The energy of the electron in the second and the third Bohr's orbits of the hydrogen atom is  $-5.42 \times 10^{-12}$  erg and  $-2.41 \times 10^{-12}$  erg respectively. Calculate the wavelength of the emitted radiation when the electron drops from the third to the second orbit. (1981 - 3 Marks)
3. Calculate the wavelength in Angstrom of the photon that is emitted when an electron in the Bohr orbit,  $n = 2$  returns to the orbit,  $n = 1$  in the hydrogen atom. The ionization potential of the ground state hydrogen atom is  $2.17 \times 10^{-11}$  erg per atom. (1982 - 4 Marks)
4. The electron energy in hydrogen atom is given by  $E = (-21.7 \times 10^{-12})/n^2$  ergs. Calculate the energy required to remove an electron completely from the  $n = 2$  orbit. What is the longest wavelength (in cm) of light that can be used to cause this transition? (1984 - 3 Marks)
12. Calculate the wave number for the shortest wavelength transition in the Balmer series of atomic hydrogen. (1996 - 1 Mark)
13. Consider the hydrogen atom to be a proton embedded in a cavity of radius  $a_0$  (Bohr radius) whose charge is neutralised by the addition of an electron to the cavity in vacuum, infinitely slowly. Estimate the average total energy of an electron in its ground state in a hydrogen atom as the work done in the above neutralisation process. Also, if the magnitude of the average kinetic energy is half the magnitude of the average potential energy, find the average potential energy. (1996 - 2 Marks)
14. Calculate the energy required to excite one litre of hydrogen gas at 1 atm and 298 K to the first excited state of atomic hydrogen. The energy for the dissociation of H-H bond is  $436 \text{ kJ mol}^{-1}$ . (2000 - 4 Marks)

## Structure of Atom

15. Wavelength of high energy transition of H-atoms is 91.2nm. Calculate the corresponding wavelength of He atoms.

(2003 - 2 Marks)

16. The Schrodinger wave equation for hydrogen atom is

(2004 - 2 Marks)

$$\Psi_{2s} = \frac{1}{4\sqrt{2\pi}} \left( \frac{1}{a_0} \right)^{3/2} \left( 2 - \frac{r_0}{a_0} \right) e^{-r_0/a_0}$$

Where  $a_0$  is Bohr's radius. If the radial node in  $2s$  be at  $r_0$ , then find  $r_0$  in terms of  $a_0$ .

17. A ball of mass 100 g is moving with  $100 \text{ ms}^{-1}$ . Find its wavelength. (2004 - 1 Mark)

18. Find the velocity ( $\text{ms}^{-1}$ ) of electron in first Bohr's orbit of radius  $a_0$ . Also find the de Broglie's wavelength (in m). Find the orbital angular momentum of  $2p$  orbital of hydrogen atom in units of  $h/2\pi$ . (2005 - 2 Marks)

## F Match the Following

Each question contains statements given in two columns, which have to be matched. The statements in Column-I are labelled A, B, C and D, while the statements in Column-II are labelled p, q, r, s and t. Any given statement in Column-I can have correct matching with ONE OR MORE statement(s) in Column-II. The appropriate bubbles corresponding to the answers to these questions have to be darkened as illustrated in the following example :

If the correct matches are A-p, s and t; B-q and r; C-p and q; and D-s then the correct darkening of bubbles will look like the given.

	p	q	r	s	t
A	<input checked="" type="checkbox"/>	<input checked="" type="checkbox"/>	<input type="checkbox"/>	<input checked="" type="checkbox"/>	<input checked="" type="checkbox"/>
B	<input type="checkbox"/>	<input checked="" type="checkbox"/>	<input checked="" type="checkbox"/>	<input type="checkbox"/>	<input type="checkbox"/>
C	<input checked="" type="checkbox"/>	<input checked="" type="checkbox"/>	<input type="checkbox"/>	<input type="checkbox"/>	<input type="checkbox"/>
D	<input type="checkbox"/>	<input type="checkbox"/>	<input type="checkbox"/>	<input checked="" type="checkbox"/>	<input type="checkbox"/>

1. According to Bohr's theory,

$E_n$  = Total energy,  $K_n$  = Kinetic energy,  $V_n$  = Potential energy,  $r_n$  = Radius of  $n^{\text{th}}$  orbit

Match the following :

### Column I

(A)  $V_n / K_n = ?$

(B) If radius of  $n^{\text{th}}$  orbit  $\propto E_n^x$ ,  $x = ?$

(C) Angular momentum in lowest orbital

(D)  $\frac{1}{r^n} \propto Z^y$ ,  $y = ?$

### Column II

(p) 0

(q) -1

(r) -2

(s) 1

(2006 - 6M)

2. Match the entries in Column I with the correctly related quantum number(s) in Column II. Indicate your answer by darkening the appropriate bubbles of the  $4 \times 4$  matrix given in the ORS (2008 - 6M)

### Column I

(A) Orbital angular momentum of the electron in a hydrogen-like atomic orbital

(B) A hydrogen-like one-electron wave function obeying Pauli principle

(C) Shape, size and orientation of hydrogen-like atomic orbitals

(D) Probability density of electron at the nucleus in hydrogen-like atom

### Column II

(p) Principal quantum number

(q) Azimuthal quantum number

(r) Magnetic quantum number

(s) Electron spin quantum number

## G Comprehension Based Questions

The hydrogen-like species  $\text{Li}^{2+}$  is in a spherically symmetric state  $S_1$  with one radial node. Upon absorbing light the ion undergoes transition to a state  $S_2$ . The state  $S_2$  has one radial node and its energy is equal to the ground state energy of the hydrogen atom. (2010)

1. The state  $S_1$  is :

(a)  $1s$  (b)  $2s$  (c)  $2p$  (d)  $3s$

2. Energy of the state  $S_1$  in units of the hydrogen atom ground state energy is :

(a) 0.75 (b) 1.50 (c) 2.25 (d) 4.50

3. The orbital angular momentum quantum number of the state  $S_2$  is :

(a) 0 (b) 1 (c) 2 (d) 3

## H Assertion & Reason Type Questions

1. **ASSERTION** : Nuclide  ${}_{13}^{30}\text{Al}$  is less stable than  ${}_{20}^{40}\text{Ca}$

(1998 - 2 Marks)

**REASON** : Nuclides having odd number of protons and neutrons are generally unstable.

- (a) If both *assertion* and *reason* are correct, and *reason* is the correct explanation of the *assertion*.  
 (b) If both *assertion* and *reason* are correct, but *reason* is not the correct explanation of the *assertion*.

- (c) If *assertion* is correct but *reason* is incorrect.  
 (d) If *assertion* is incorrect but *reason* is correct.
2. This question contains STATEMENT-1 (Assertion) and STATEMENT-2 (Reason) and has 4 choices (a), (b), (c) and (d) out of which ONLY ONE is correct.

STATEMENT-1 : Band gap in germanium is small. because

STATEMENT-2 : The energy gap of each germanium atomic energy level is infinitesimally small. (2007)

- (a) Statement-1 is True, Statement-2 is True; Statement-2 is a correct explanation for Statement-1  
 (b) Statement-1 is True, Statement-2 is True; Statement-2 is not a correct explanation for Statement-1  
 (c) Statement-1 is True, Statement-2 is False  
 (d) Statement-1 is False, Statement-2 is True.
3. STATEMENT-1 : The plot of atomic number (y-axis) versus number of neutrons (x-axis) for stable nuclei shows a curvature towards x-axis from the line of 45° slope as the atomic number is increased.  
 STATEMENT-2 : Proton-proton electrostatic repulsions begin to overcome attractive forces involving protons and neutrons in heavier nuclides. (2008)
- (a) Statement-1 is True, Statement-2 is True; Statement-2 is a correct explanation for Statement-1.  
 (b) Statement-1 is True, Statement-2 is True; Statement-2 is NOT a correct explanation for Statement-1  
 (c) Statement-1 is True, Statement-2 is False  
 (d) Statement-1 is False, Statement-2 is True

## I Integer Value Correct Type

1. The work function ( $\phi$ ) of some metals is listed below. The number of metals which will show photoelectric effect when light of 300 nm wavelength falls on the metal is (2011)

Metal	Li	Na	K	Mg	Cu	Ag	Fe	Pt	W
$\phi$ (eV)	2.4	2.3	2.2	3.7	4.8	4.3	4.7	6.3	4.75

2. The maximum number of electrons that can have principal quantum number,  $n = 3$ , and spin quantum  $m_s = -\frac{1}{2}$ , is (2011)
3. The atomic masses of 'He' and 'Ne' are 4 and 20 a.m.u., respectively. The value of the de Broglie wavelength of 'He' gas at  $-73^\circ\text{C}$  is "M" times that of the de Broglie wavelength of 'Ne' at  $727^\circ\text{C}$  'M' is (JEE Adv. 2013)
4. In an atom, the total number of electrons having quantum numbers  $n = 4$ ,  $|m_l| = 1$  and  $m_s = -\frac{1}{2}$  is (JEE Adv. 2014)
5. Not considering the electronic spin, the degeneracy of the second excited state ( $n = 3$ ) of H atom is 9, while the degeneracy of the second excited state of  $\text{H}^-$  is (JEE Adv. 2015)

## Section-B JEE Main / AIEEE

1. In a hydrogen atom, if energy of an electron in ground state is 13.6 eV, then that in the 2<sup>nd</sup> excited state is [2002]  
 (a) 1.51 eV (b) 3.4 eV  
 (c) 6.04 eV (d) 13.6 eV.
2. Uncertainty in position of a minute particle of mass 25 g in space is  $10^{-5}$  m. What is the uncertainty in its velocity (in  $\text{ms}^{-1}$ )? ( $h = 6.6 \times 10^{-34}$  Js) [2002]  
 (a)  $2.1 \times 10^{-34}$  (b)  $0.5 \times 10^{-34}$   
 (c)  $2.1 \times 10^{-28}$  (d)  $0.5 \times 10^{-23}$ .
3. The number of d-electrons retained in  $\text{Fe}^{2+}$  [2003]  
 (At. no. of Fe = 26) ion is  
 (a) 4 (b) 5  
 (c) 6 (d) 3
4. The orbital angular momentum for an electron revolving in an orbit is given by  $\sqrt{l(l+1)} \cdot \frac{h}{2\pi}$ . This momentum for an s-electron will be given by [2003]  
 (a) zero (b)  $\frac{h}{2\pi}$   
 (c)  $\sqrt{2} \cdot \frac{h}{2\pi}$  (d)  $+\frac{1}{2} \cdot \frac{h}{2\pi}$
5. Which one of the following groupings represents a collection of isoelectronic species ? (At. nos. : Cs : 55, Br : 35) [2003]  
 (a)  $\text{N}^{3-}, \text{F}^-, \text{Na}^+$  (b)  $\text{Be}, \text{Al}^{3+}, \text{Cl}^-$   
 (c)  $\text{Ca}^{2+}, \text{Cs}^+, \text{Br}$  (d)  $\text{Na}^+, \text{Ca}^{2+}, \text{Mg}^{2+}$
6. In Bohr series of lines of hydrogen spectrum, the third line from the red end corresponds to which one of the following inter-orbit jumps of the electron for Bohr orbits in an atom of hydrogen [2003]  
 (a)  $5 \rightarrow 2$  (b)  $4 \rightarrow 1$   
 (c)  $2 \rightarrow 5$  (d)  $3 \rightarrow 2$
7. The de Broglie wavelength of a tennis ball of mass 60 g moving with a velocity of 10 metres per second is approximately [2003]  
 (a)  $10^{-31}$  metres (b)  $10^{-16}$  metres  
 (c)  $10^{-25}$  metres (d)  $10^{-33}$  metres  
 Planck's constant,  $h = 6.63 \times 10^{-34}$  Js
8. Which of the following sets of quantum numbers is correct for an electron in 4f orbital ? [2004]  
 (a)  $n = 4, \ell = 3, m = +1, s = +\frac{1}{2}$   
 (b)  $n = 4, \ell = 4, m = -4, s = -\frac{1}{2}$   
 (c)  $n = 4, \ell = 3, m = +4, s = +\frac{1}{2}$   
 (d)  $n = 3, \ell = 2, m = -2, s = +\frac{1}{2}$

9. Consider the ground state of Cr atom ( $X = 24$ ). The number of electrons with the azimuthal quantum numbers,  $\ell = 1$  and 2 are, respectively [2004]  
 (a) 16 and 4 (b) 12 and 5  
 (c) 12 and 4 (d) 16 and 5
10. The wavelength of the radiation emitted, when in a hydrogen atom electron falls from infinity to stationary state 1, would be (Rydberg constant =  $1.097 \times 10^7 \text{ m}^{-1}$ ) [2004]  
 (a) 406 nm (b) 192 nm  
 (c) 91 nm (d)  $9.1 \times 10^{-8} \text{ nm}$
11. Which one of the following sets of ions represents the collection of isoelectronic species? [2004]  
 (a)  $\text{K}^+, \text{Cl}^-, \text{Mg}^{2+}, \text{Sc}^{3+}$  (b)  $\text{Na}^+, \text{Ca}^{2+}, \text{Sc}^{3+}, \text{F}^-$   
 (c)  $\text{K}^+, \text{Ca}^{2+}, \text{Sc}^{3+}, \text{Cl}^-$  (d)  $\text{Na}^+, \text{Mg}^{2+}, \text{Al}^{3+}, \text{Cl}^-$   
 (Atomic nos. : F = 9, Cl = 17, Na = 11, Mg = 12, Al = 13, K = 19, Ca = 20, Sc = 21)
12. In a multi-electron atom, which of the following orbitals described by the three quantum numbers will have the same energy in the absence of magnetic and electric fields? [2005]  
 (A)  $n = 1, l = 0, m = 0$  (B)  $n = 2, l = 0, m = 0$   
 (C)  $n = 2, l = 1, m = 1$  (D)  $n = 3, l = 2, m = 1$   
 (E)  $n = 3, l = 2, m = 0$   
 (a) (D) and (E) (b) (C) and (D)  
 (c) (B) and (C) (d) (A) and (B)
13. Of the following sets which one does NOT contain isoelectronic species? [2005]  
 (a)  $\text{BO}_3^{3-}, \text{CO}_3^{2-}, \text{NO}_3^-$  (b)  $\text{SO}_3^{2-}, \text{CO}_3^{2-}, \text{NO}_3^-$   
 (c)  $\text{CN}^-, \text{N}_2, \text{C}_2^{2-}$  (d)  $\text{PO}_4^{3-}, \text{SO}_4^{2-}, \text{ClO}_4^-$
14. According to Bohr's theory, the angular momentum of an electron in 5<sup>th</sup> orbit is [2006]  
 (a)  $10 h / \pi$  (b)  $2.5 h / \pi$   
 (c)  $25 h / \pi$  (d)  $1.0 h / \pi$
15. Uncertainty in the position of an electron (mass =  $9.1 \times 10^{-31} \text{ kg}$ ) moving with a velocity  $300 \text{ ms}^{-1}$ , accurate upto 0.001% will be [2006]  
 (a)  $1.92 \times 10^{-2} \text{ m}$  (b)  $3.84 \times 10^{-2} \text{ m}$   
 (c)  $19.2 \times 10^{-2} \text{ m}$  (d)  $5.76 \times 10^{-2} \text{ m}$   
 ( $h = 6.63 \times 10^{-34} \text{ Js}$ )
16. Which one of the following sets of ions represents a collection of isoelectronic species? [2006]  
 (a)  $\text{N}^{3-}, \text{O}^{2-}, \text{F}^-, \text{S}^{2-}$  (b)  $\text{Li}^+, \text{Na}^+, \text{Mg}^{2+}, \text{Ca}^{2+}$   
 (c)  $\text{K}^+, \text{Cl}^-, \text{Ca}^{2+}, \text{Sc}^{3+}$  (d)  $\text{Ba}^{2+}, \text{Sr}^{2+}, \text{K}^+, \text{Ca}^{2+}$
17. Which of the following sets of quantum numbers represents the highest energy of an atom? [2007]  
 (a)  $n = 3, l = 0, m = 0, s = +1/2$   
 (b)  $n = 3, l = 1, m = 1, s = +1/2$   
 (c)  $n = 3, l = 2, m = 1, s = +1/2$   
 (d)  $n = 4, l = 0, m = 0, s = +1/2$
18. Which one of the following constitutes a group of the isoelectronic species? [2008]  
 (a)  $\text{C}_2^{2-}, \text{O}_2^-, \text{CO}, \text{NO}$  (b)  $\text{NO}^+, \text{C}_2^{2-}, \text{CN}^-, \text{N}_2$   
 (c)  $\text{CN}^-, \text{N}_2, \text{O}_2^{2-}, \text{C}_2^{2-}$  (d)  $\text{N}_2, \text{O}_2^-, \text{NO}^+, \text{CO}$
19. The ionization enthalpy of hydrogen atom is  $1.312 \times 10^6 \text{ J mol}^{-1}$ . The energy required to excite the electron in the atom from  $n = 1$  to  $n = 2$  is [2008]  
 (a)  $8.51 \times 10^5 \text{ J mol}^{-1}$  (b)  $6.56 \times 10^5 \text{ J mol}^{-1}$   
 (c)  $7.56 \times 10^5 \text{ J mol}^{-1}$  (d)  $9.84 \times 10^5 \text{ J mol}^{-1}$
20. Calculate the wavelength (in nanometer) associated with a proton moving at  $1.0 \times 10^3 \text{ ms}^{-1}$ . (Mass of proton =  $1.67 \times 10^{-27} \text{ kg}$  and  $h = 6.63 \times 10^{-34} \text{ Js}$ ) [2009]  
 (a) 0.40 nm (b) 2.5 nm  
 (c) 14.0 nm (d) 0.32 nm
21. In an atom, an electron is moving with a speed of 600 m/s with an accuracy of 0.005%. Certainty with which the position of the electron can be located is ( $h = 6.6 \times 10^{-34} \text{ kg m}^2 \text{ s}^{-1}$ , mass of electron,  $e_m = 9.1 \times 10^{-31} \text{ kg}$ ): [2009]  
 (a)  $5.10 \times 10^{-3} \text{ m}$  (b)  $1.92 \times 10^{-3} \text{ m}$   
 (c)  $3.84 \times 10^{-3} \text{ m}$  (d)  $1.52 \times 10^{-4} \text{ m}$
22. The energy required to break one mole of Cl – Cl bonds in  $\text{Cl}_2$  is  $242 \text{ kJ mol}^{-1}$ . The longest wavelength of light capable of breaking a single Cl – Cl bond is ( $c = 3 \times 10^8 \text{ ms}^{-1}$  and  $N_A = 6.02 \times 10^{23} \text{ mol}^{-1}$ ). [2010]  
 (a) 594 nm (b) 640 nm  
 (c) 700 nm (d) 494 nm
23. Ionisation energy of  $\text{He}^+$  is  $19.6 \times 10^{-18} \text{ J atom}^{-1}$ . The energy of the first stationary state ( $n = 1$ ) of  $\text{Li}^{2+}$  is [2010]  
 (a)  $4.41 \times 10^{-16} \text{ J atom}^{-1}$  (b)  $-4.41 \times 10^{-17} \text{ J atom}^{-1}$   
 (c)  $-2.2 \times 10^{-15} \text{ J atom}^{-1}$  (d)  $8.82 \times 10^{-17} \text{ J atom}^{-1}$
24. A gas absorbs a photon of 355 nm and emits at two wavelengths. If one of the emissions is at 680 nm, the other is at: [2011]  
 (a) 1035 nm (b) 325 nm  
 (c) 743 nm (d) 518 nm

25. The electrons identified by quantum numbers  $n$  and  $\ell$  :

(A)  $n=4, \ell=1$                       (B)  $n=4, \ell=0$

(C)  $n=3, \ell=2$                       (D)  $n=3, \ell=1$

can be placed in order of increasing energy as : [2012]

(a)  $(C) < (D) < (B) < (A)$       (b)  $(D) < (B) < (C) < (A)$

(c)  $(B) < (D) < (A) < (C)$       (d)  $(A) < (C) < (B) < (D)$

26. Energy of an electron is given by  $E = -2.178 \times 10^{-18} \text{J} \left( \frac{Z^2}{n^2} \right)$ .

Wavelength of light required to excite an electron in an hydrogen atom from level  $n=1$  to  $n=2$  will be :

( $h = 6.62 \times 10^{-34} \text{Js}$  and  $c = 3.0 \times 10^8 \text{ms}^{-1}$ ) [JEE M 2013]

(a)  $1.214 \times 10^{-7} \text{m}$                       (b)  $2.816 \times 10^{-7} \text{m}$

(c)  $6.500 \times 10^{-7} \text{m}$                       (d)  $8.500 \times 10^{-7} \text{m}$

27. The correct set of four quantum numbers for the valence electrons of rubidium atom ( $Z=37$ ) is: [JEE M 2014]

(a)  $5, 0, 0, +\frac{1}{2}$

(b)  $5, 1, 0, +\frac{1}{2}$

(c)  $5, 1, 1, +\frac{1}{2}$

(d)  $5, 0, 1, +\frac{1}{2}$

28. Which of the following is the energy of a possible excited state of hydrogen ? [JEE M 2015]

(a)  $-3.4 \text{eV}$

(b)  $+6.8 \text{eV}$

(c)  $+13.6 \text{eV}$

(d)  $-6.8 \text{eV}$

29. A stream of electrons from a heated filaments was passed two charged plates kept at a potential difference  $V$  esu. If  $e$  and  $m$  are charge and mass of an electron, respectively, then the value of  $h/\lambda$  (where  $\lambda$  is wavelength associated with electron wave) is given by: [JEE M 2016]

(a)  $\sqrt{meV}$

(b)  $\sqrt{2meV}$

(c)  $meV$

(d)  $2meV$

## CHAPTER

## 3

# Classification of Elements and Periodicity in Properties

## Section-A

## JEE Advanced/ IIT-JEE

**A Fill in the Blanks**

- The energy released when an electron is added to a neutral gaseous atom is called ..... of the atom. (1982 - 1 Mark)
- On Mulliken scale, the average of ionization potential and electron affinity is known as ..... (1985 - 1 Mark)

**B True / False**

- In group IA, of alkali metals, the ionisation potential decreases on moving down the group. Therefore, lithium is a strongest reducing agent. (1987 - 1 Mark)
- The decreasing order of electron affinity of F, Cl, Br is  $F > Cl > Br$ . (1993 - 1 Mark)
- The basic nature of the hydroxides of group 13 (Gr. III B) decreases progressively down the group. (1993 - 1 Mark)

**C MCQs with One Correct Answer**

- The correct order of second ionisation potential of carbon, nitrogen, oxygen and fluorine is (1981 - 1 Mark)
  - $C > N > O > F$
  - $O > N > F > C$
  - $O > F > N > C$
  - $F > O > N > C$
- The element with the highest first ionization potential is (1982 - 1 Mark)
  - boron
  - carbon
  - nitrogen
  - oxygen
- The first ionisation potential in electron volts of nitrogen and oxygen atoms are respectively given by (1987 - 1 Mark)
  - 14.6, 13.6
  - 13.6, 14.6
  - 13.6, 13.6
  - 14.6, 14.6
- Atomic radii of fluorine and neon in Ångstrom units are respectively given by (1987 - 1 Mark)
  - 0.72, 1.60
  - 1.60, 1.60
  - 0.72, 0.72
  - None of these values
- The electronegativity of the following elements increases in the order (1987 - 1 Mark)
  - C, N, Si, P
  - N, Si, C, P
  - Si, P, C, N
  - P, Si, N, C
- The first ionisation potential of Na, Mg, Al and Si are in the order (1988 - 1 Mark)
  - $Na < Mg > Al < Si$
  - $Na > Mg > Al > Si$
  - $Na < Mg < Al < Si$
  - $Na > Mg > Al < Si$
- Which one of the following is the strongest base?
  - $AsH_3$
  - $NH_3$
  - $PH_3$
  - $SbH_3$
- Which one of the following is the smallest in size?
  - $N^{3-}$
  - $O^{2-}$
  - $F^-$
  - $Na^+$
- Amongst the following elements (whose electronic configurations are given below), the one having the highest ionization energy is : (1990 - 1 Mark)
  - $[Ne] 3s^2 3p^1$
  - $[Ne] 3s^2 3p^3$
  - $[Ne] 3s^2 3p^2$
  - $[Ne] 3d^{10} 4s^2 4p^3$
- The statement that is not correct for the periodic classification of element is (1992 - 1 Mark)
  - The properties of elements are the periodic functions of their atomic numbers
  - Non-metallic elements are lesser in number than metallic elements
  - The first ionisation energies of elements along a period do not vary in a regular manner with increase in atomic number
  - For transition elements the  $d$ -subshells are filled with electrons monotonically with increase in atomic number.
- Which has most stable +2 oxidation state : (1995S)
  - Sn
  - Pb
  - Fe
  - Ag

12. Which of the following has the maximum number of unpaired electrons? (1996 - 1 Mark)
- (a)  $\text{Mg}^{2+}$  (b)  $\text{Ti}^{3+}$   
(c)  $\text{V}^{3+}$  (d)  $\text{Fe}^{2+}$
13. The correct order of radii is (2000S)
- (a)  $\text{N} < \text{Be} < \text{B}$  (b)  $\text{F}^- < \text{O}^{2-} < \text{N}^{3-}$   
(c)  $\text{Na} < \text{Li} < \text{K}$  (d)  $\text{Fe}^{3+} < \text{Fe}^{2+} < \text{Fe}^{4+}$
14. The correct order of acidic strength is (2000S)
- (a)  $\text{Cl}_2\text{O}_7 > \text{SO}_2 > \text{P}_4\text{O}_{10}$  (b)  $\text{CO}_2 > \text{N}_2\text{O}_5 > \text{SO}_3$   
(c)  $\text{Na}_2\text{O} > \text{MgO} > \text{Al}_2\text{O}_3$  (d)  $\text{K}_2\text{O} > \text{CaO} > \text{MgO}$
15. Amongst  $\text{H}_2\text{O}$ ,  $\text{H}_2\text{S}$ ,  $\text{H}_2\text{Se}$  and  $\text{H}_2\text{Te}$ , the one with the highest boiling point is (2000S)
- (a)  $\text{H}_2\text{O}$  because of hydrogen bonding  
(b)  $\text{H}_2\text{Te}$  because of higher molecular weight  
(c)  $\text{H}_2\text{S}$  because of hydrogen bonding  
(d)  $\text{H}_2\text{Se}$  because of lower molecular weight
16. Identify the correct order of acidic strengths of  $\text{CO}_2$ ,  $\text{CuO}$ ,  $\text{CaO}$ ,  $\text{H}_2\text{O}$  (2002S)
- (a)  $\text{CaO} < \text{CuO} < \text{H}_2\text{O} < \text{CO}_2$  (b)  $\text{H}_2\text{O} < \text{CuO} < \text{CaO} < \text{CO}_2$   
(c)  $\text{CaO} < \text{H}_2\text{O} < \text{CuO} < \text{CO}_2$  (d)  $\text{H}_2\text{O} < \text{CO}_2 < \text{CaO} < \text{CuO}$

### D MCQs with One or More Than One Correct

1. The statements that are true for the long form of the periodic table are : (1988 - 1 Mark)
- (a) it reflects the sequence of filling the electrons in the order of sub-energy level s, p, d and f.  
(b) it helps to predict the stable valency states of the elements  
(c) it reflects trends in physical and chemical properties of the elements  
(d) it helps to predict the relative ionicity of the bond between any two elements.
2. Sodium sulphate is soluble in water whereas barium sulphate is sparingly soluble because : (1989 - 1 Mark)
- (a) the hydration energy of sodium sulphate is more than its lattice energy  
(b) the lattice energy of barium sulphate is more than its hydration energy  
(c) the lattice energy has no role to play in solubility  
(d) the hydration energy of sodium sulphate is less than its lattice energy.

3. Ionic radii of (1999 - 3 Marks)
- (a)  $\text{Ti}^{4+} < \text{Mn}^{7+}$  (b)  $^{35}\text{Cl}^- < ^{37}\text{Cl}^-$   
(c)  $\text{K}^+ > \text{Cl}^-$  (d)  $\text{P}^{3+} > \text{P}^{5+}$

### E Subjective Problems

1. Arrange the following in :
- (i) Decreasing ionic size :  $\text{Mg}^{2+}$ ,  $\text{O}^{2-}$ ,  $\text{Na}^+$ ,  $\text{F}^-$  (1985 - 1 Mark)  
(ii) Increasing acidic property :  $\text{ZnO}$ ,  $\text{Na}_2\text{O}_2$ ,  $\text{P}_2\text{O}_5$ ,  $\text{MgO}$  (1985 - 1 Mark)  
(iii) Increasing first ionization potential :  $\text{Mg}$ ,  $\text{Al}$ ,  $\text{Si}$ ,  $\text{Na}$  (1985 - 1 Mark)  
(iv) Increasing size :  $\text{Cl}^-$ ,  $\text{S}^{2-}$ ,  $\text{Ca}^{2+}$ ,  $\text{Ar}$  (1986 - 1 Mark)  
(v) Increasing order of ionic size :  $\text{N}^{3-}$ ,  $\text{Na}^+$ ,  $\text{F}^-$ ,  $\text{O}^{2-}$ ,  $\text{Mg}^{2+}$  (1991 - 1 Mark)  
(vi) Increasing order of basic character :  $\text{MgO}$ ,  $\text{SrO}$ ,  $\text{K}_2\text{O}$ ,  $\text{NiO}$ ,  $\text{Cs}_2\text{O}$  (1991 - 1 Mark)  
(vii) Arrange the following ions in order of their increasing radii :  $\text{Li}^+$ ,  $\text{Mg}^{2+}$ ,  $\text{K}^+$ ,  $\text{Al}^{3+}$ .
2. The first ionization energy of carbon atom is greater than that of boron atom whereas, the reverse is true for the second ionization energy. (1989 - 2 Marks)

### H Assertion & Reason Type Questions

1. Read the following statement and explanation and answer as per the options given below :
- ASSERTION :** The first ionization energy of Be is greater than that of B. (2000S)
- REASON :**  $2p$  orbital is lower in energy than  $2s$
- (a) If both assertion and reason are CORRECT, and reason is the CORRECT explanation of the assertion.  
(b) If both assertion and reason are CORRECT, but reason is NOT the CORRECT explanation of the assertion.  
(c) If assertion is CORRECT, but reason is INCORRECT.  
(d) If assertion is INCORRECT, but reason is CORRECT.

### I Integer Value Correct Type

1. Among the following, the number of elements showing only one non-zero oxidation state is :  
 $\text{O}$ ,  $\text{Cl}$ ,  $\text{F}$ ,  $\text{N}$ ,  $\text{P}$ ,  $\text{Sn}$ ,  $\text{Tl}$ ,  $\text{Na}$ ,  $\text{Ti}$  (2010)



## Section-B

## JEE Main / AIEEE

- According to the Periodic Law of elements, the variation in properties of elements is related to their [2003]
  - nuclear masses
  - atomic numbers
  - nuclear neutron-proton number ratios
  - atomic masses
- Which one of the following is an amphoteric oxide? [2003]
  - $\text{Na}_2\text{O}$
  - $\text{SO}_2$
  - $\text{B}_2\text{O}_3$
  - $\text{ZnO}$
- Which one of the following ions has the highest value of ionic radius? [2004]
  - $\text{O}^{2-}$
  - $\text{B}^{3+}$
  - $\text{Li}^+$
  - $\text{F}^-$
- Among  $\text{Al}_2\text{O}_3$ ,  $\text{SiO}_2$ ,  $\text{P}_2\text{O}_3$  and  $\text{SO}_2$  the correct order of acid strength is [2004]
  - $\text{Al}_2\text{O}_3 < \text{SiO}_2 < \text{SO}_2 < \text{P}_2\text{O}_3$
  - $\text{SiO}_2 < \text{SO}_2 < \text{Al}_2\text{O}_3 < \text{P}_2\text{O}_3$
  - $\text{SO}_2 < \text{P}_2\text{O}_3 < \text{SiO}_2 < \text{Al}_2\text{O}_3$
  - $\text{Al}_2\text{O}_3 < \text{SiO}_2 < \text{P}_2\text{O}_3 < \text{SO}_2$
- The formation of the oxide ion  $\text{O}_{(\text{g})}^{2-}$  requires first an exothermic and then an endothermic step as shown below
 
$$\text{O}_{(\text{g})} + \text{e}^- = \text{O}_{(\text{g})}^- \quad \Delta H^\circ = -142 \text{ kJmol}^{-1} \quad [2004]$$

$$\text{O}^-(\text{g}) + \text{e}^- = \text{O}_{(\text{g})}^{2-} \quad \Delta H^\circ = 844 \text{ kJmol}^{-1}$$
 This is because
  - $\text{O}^-$  ion will tend to resist the addition of another electron
  - Oxygen has high electron affinity
  - Oxygen is more electronegative
  - $\text{O}^-$  ion has comparatively larger size than oxygen atom
- Which of the following oxides is amphoteric in character? [2005]
  - $\text{SnO}_2$
  - $\text{SiO}_2$
  - $\text{CO}_2$
  - $\text{CaO}$
- In which of the following arrangements, the order is NOT according to the property indicated against it? [2005]
  - $\text{Li} < \text{Na} < \text{K} < \text{Rb}$  : Increasing metallic radius
  - $\text{I} < \text{Br} < \text{F} < \text{Cl}$  : Increasing electron gain enthalpy (with negative sign)
  - $\text{B} < \text{C} < \text{N} < \text{O}$  : Increasing first ionization enthalpy
  - $\text{Al}^{3+} < \text{Mg}^{2+} < \text{Na}^+ < \text{F}^-$  : Increasing ionic size
- Following statements regarding the periodic trends of chemical reactivity of the alkali metals and the halogens are given. Which of these statements gives the correct picture? [2006]
  - Chemical reactivity increases with increase in atomic number down the group in both the alkali metals and halogens
  - In alkali metals the reactivity increases but in the halogens it decreases with increase in atomic number down the group
  - The reactivity decreases in the alkali metals but increases in the halogens with increase in atomic number down the group
  - In both the alkali metals and the halogens the chemical reactivity decreases with increase in atomic number down the group
- In which of the following arrangements, the sequence is *not* strictly according to the property written against it? [2008]
  - $\text{HF} < \text{HCl} < \text{HBr}$ ,  $\text{HI}$  : increasing acid strength
  - $\text{NH}_3 < \text{PH}_3 < \text{AsH}_3 < \text{SbH}_3$  : increasing basic strength
  - $\text{B} < \text{C} < \text{O} < \text{N}$  : increasing first ionization enthalpy
  - $\text{CO}_2 < \text{SiO}_2 < \text{SnO}_2 < \text{PbO}_2$  : increasing oxidising power
- The correct sequence which shows decreasing order of the ionic radii of the elements is [2010]
  - $\text{Al}^{3+} > \text{Mg}^{2+} > \text{Na}^+ > \text{F}^- > \text{O}^{2-}$
  - $\text{Na}^+ > \text{Mg}^{2+} > \text{Al}^{3+} > \text{O}^{2-} > \text{F}^-$
  - $\text{Na}^+ > \text{F}^- > \text{Mg}^{2+} > \text{O}^{2-} > \text{Al}^{3+}$
  - $\text{O}^{2-} > \text{F}^- > \text{Na}^+ > \text{Mg}^{2+} > \text{Al}^{3+}$
- Which one of the following orders presents the correct sequence of the increasing basic nature of the given oxides? [2011]
  - $\text{Al}_2\text{O}_3 < \text{MgO} < \text{Na}_2\text{O} < \text{K}_2\text{O}$
  - $\text{MgO} < \text{K}_2\text{O} < \text{Al}_2\text{O}_3 < \text{Na}_2\text{O}$
  - $\text{Na}_2\text{O} < \text{K}_2\text{O} < \text{MgO} < \text{Al}_2\text{O}_3$
  - $\text{K}_2\text{O} < \text{Na}_2\text{O} < \text{Al}_2\text{O}_3 < \text{MgO}$
- The increasing order of the ionic radii of the given isoelectronic species is : [2012]
  - $\text{Cl}^-, \text{Ca}^{2+}, \text{K}^+, \text{S}^{2-}$
  - $\text{S}^{2-}, \text{Cl}^-, \text{Ca}^{2+}, \text{K}^+$
  - $\text{Ca}^{2+}, \text{K}^+, \text{Cl}^-, \text{S}^{2-}$
  - $\text{K}^+, \text{S}^{2-}, \text{Ca}^{2+}, \text{Cl}^-$

13. Which of the following represents the correct order of increasing first ionization enthalpy for Ca, Ba, S, Se and Ar?  
[JEE M 2013]
- (a)  $\text{Ca} < \text{S} < \text{Ba} < \text{Se} < \text{Ar}$  (b)  $\text{S} < \text{Se} < \text{Ca} < \text{Ba} < \text{Ar}$   
(c)  $\text{Ba} < \text{Ca} < \text{Se} < \text{S} < \text{Ar}$  (d)  $\text{Ca} < \text{Ba} < \text{S} < \text{Se} < \text{Ar}$
14. The first ionisation potential of Na is 5.1 eV. The value of electron gain enthalpy of  $\text{Na}^+$  will be : [JEE M 2013]
- (a) -2.55 eV (b) -5.1 eV  
(c) -10.2 eV (d) +2.55 eV
15. The ionic radii (in Å) of  $\text{N}^{3-}$ ,  $\text{O}^{2-}$  and  $\text{F}^-$  are respectively : [JEE M 2015]
- (a) 1.71, 1.40 and 1.36 (b) 1.71, 1.36 and 1.40  
(c) 1.36, 1.40 and 1.71 (d) 1.36, 1.71 and 1.40

## CHAPTER

## 4

Chemical Bonding  
and Molecular Structure

## Section-A

## JEE Advanced/ IIT-JEE

## A Fill in the Blanks

- The angle between two covalent bonds is maximum in ..... ( $\text{CH}_4, \text{H}_2\text{O}, \text{CO}_2$ ) (1981 - 1 Mark)
- Pair of molecules which forms strongest intermolecular hydrogen bond is .....  
( $\text{SiH}_4$  and  $\text{SiF}_4$ ,  $\text{CH}_3-\overset{\text{O}}{\parallel}{\text{C}}-\text{CH}_3$  and  $\text{CHCl}_3$ ,  $\text{H}-\overset{\text{O}}{\parallel}{\text{C}}-\text{OH}$  and  $\text{CH}_3-\overset{\text{O}}{\parallel}{\text{C}}-\text{OH}$ ) (1981 - 1 Mark)
- There are .....  $\pi$  bonds in a nitrogen molecule. (1982 - 1 Mark)
- ..... hybrid orbitals of nitrogen atom are involved in the formation of ammonium ion. (1982 - 1 Mark)
- The shape of  $[\text{CH}_3]^+$  is ..... (1990 - 1 Mark)
- The two types of bonds present in  $\text{B}_2\text{H}_6$  are covalent and ..... (1994 - 1 Mark)
- When  $\text{N}_2$  goes to  $\text{N}_2^+$ , the N-N bond distance ..., and when  $\text{O}_2$  goes to  $\text{O}_2^+$  the O-O bond distance.... (1996 - 1 Mark)

## B True / False

- Linear overlap of two atomic p-orbitals leads to a sigma bond. (1983 - 1 Mark)
- All molecules with polar bonds have dipole moment. (1985 - 1/2 Mark)
- $\text{SnCl}_2$  is a non-linear molecule. (1985 - 1/2 Mark)
- In benzene, carbon uses all the three p-orbitals for hybridisation. (1987 - 1 Mark)
- $sp^2$  hybrid orbitals have equal s and p character. (1987 - 1 Mark)
- The presence of polar bonds in a poly-atomic molecule suggests that the molecule has non-zero dipole moment. (1990 - 1 Mark)
- The dipole moment of  $\text{CH}_3\text{F}$  is greater than that of  $\text{CH}_3\text{Cl}$ . (1993 - 1 Mark)

## C MCQs with One Correct Answer

- (a)  $\text{CH}_4$  (b)  $\text{H}_2$  (c) KCN (d) KCl
  - The octet rule is not valid for the molecule (1979)  
(a)  $\text{CO}_2$  (b)  $\text{H}_2\text{O}$  (c)  $\text{O}_2$  (d) CO
  - Element X is strongly electropositive and element Y is strongly electronegative. Both are univalent. The compound formed would be (1980)  
(a)  $\text{X}^+\text{Y}^-$  (b)  $\text{X}-\text{X}^+$  (c)  $\text{X}-\text{Y}$  (d)  $\text{X} \rightarrow \text{Y}$
  - Which of the following compounds are covalent? (1980)  
(a)  $\text{H}_2$  (b) CaO (c) KCl (d)  $\text{Na}_2\text{S}$
  - The total number of electrons that take part in forming the bond in  $\text{N}_2$  is (1980)  
(a) 2 (b) 4 (c) 6 (d) 10
  - Which of the following is soluble in water (1980)  
(a)  $\text{CS}_2$  (b)  $\text{C}_2\text{H}_5\text{OH}$   
(c)  $\text{CCl}_4$  (d)  $\text{CHCl}_3$
  - If a molecule  $\text{MX}_3$  has zero dipole moment, the sigma bonding orbitals used by M (atomic number < 21) are (1981 - 1 Mark)  
(a) pure p (b) sp hybrid  
(c)  $sp^2$  hybrid (d)  $sp^3$  hybrid
  - The ion that is isoelectronic with CO is (1982 - 1 Mark)  
(a)  $\text{CN}^-$  (b)  $\text{O}_2^+$  (c)  $\text{O}_2^-$  (d)  $\text{N}_2^+$
  - Among the following, the molecule that is linear is (1982 - 1 Mark)  
(a)  $\text{CO}_2$  (b)  $\text{NO}_2$   
(c)  $\text{SO}_2$  (d)  $\text{ClO}_2$
  - The compound with no dipole moment is (1982 - 1 Mark)  
(a) methyl chloride (b) carbon tetrachloride  
(c) methylene chloride (d) chloroform
  - Carbon tetrachloride has no net dipole moment because of (1983 - 1 Mark)  
(a) its planar structure  
(b) its regular tetrahedral structure  
(c) similar sizes of carbon and chlorine  
(d) similar electron affinities of carbon and chlorine
  - Which one among the following does not have the hydrogen bond? (1983 - 1 Mark)  
(a) phenol (b) liquid  $\text{NH}_3$   
(c) water (d) liquid HCl
  - The types of bonds present in  $\text{CuSO}_4 \cdot 5\text{H}_2\text{O}$  are only (1983 - 1 Mark)  
(a) electrovalent and covalent  
(b) electrovalent and coordinate covalent  
(c) electrovalent, covalent and coordinate covalent  
(d) covalent and coordinate covalent
- The compound which contains both ionic and covalent bonds is (1979)

14. On hybridization of one  $s$  and one  $p$  orbitals we get :  
 (a) two mutually perpendicular orbitals (1984 - 1 Mark)  
 (b) two orbitals at  $180^\circ$   
 (c) four orbitals directed tetrahedrally  
 (d) three orbitals in a plane
15. The molecule having one unpaired electron is :  
 (1985 - 1 Mark)  
 (a) NO (b) CO (c)  $\text{CN}^-$  (d)  $\text{O}_2$
16. The bond between two identical non-metal atoms has a pair of electrons :  
 (1986 - 1 Mark)  
 (a) unequally shared between the two  
 (b) transferred fully from one atom to another  
 (c) with identical spins  
 (d) equally shared between them
17. The hydrogen bond is strongest in : (1986 - 1 Mark)  
 (a)  $\text{O}-\text{H}\cdots\cdots\text{S}$  (b)  $\text{S}-\text{H}\cdots\cdots\text{O}$   
 (c)  $\text{F}-\text{H}\cdots\cdots\text{F}$  (d)  $\text{F}-\text{H}\cdots\cdots\text{O}$
18. The hybridisation of sulphur in sulphur dioxide is :  
 (1986 - 1 Mark)  
 (a)  $sp$  (b)  $sp^3$  (c)  $sp^2$  (d)  $dsp^2$
19. Hydrogen bonding is maximum in (1987 - 1 Mark)  
 (a) Ethanol (b) Diethyl ether  
 (c) Ethyl chloride (d) Triethylamine
20. The species in which the central atom uses  $sp^2$  hybrid orbitals in its bonding is (1988 - 1 Mark)  
 (a)  $\text{PH}_3$  (b)  $\text{NH}_3$  (c)  $\text{CH}_3^+$  (d)  $\text{SbH}_3$
21. The molecule that has linear structure is (1988 - 1 Mark)  
 (a)  $\text{CO}_2$  (b)  $\text{NO}_2$  (c)  $\text{SO}_2$  (d)  $\text{SiO}_2$
22. The molecule which has zero dipole moment is : (1989 - 1 Mark)  
 (a)  $\text{CH}_2\text{Cl}_2$  (b)  $\text{BF}_3$   
 (c)  $\text{NF}_3$  (d)  $\text{ClO}_2$
23. The molecule which has pyramidal shape is : (1989 - 1 Mark)  
 (a)  $\text{PCl}_3$  (b)  $\text{SO}_3$   
 (c)  $\text{CO}_3^{2-}$  (d)  $\text{NO}_3^-$
24. The compound in which  $\overset{*}{\text{C}}$  uses its  $sp^3$  hybrid orbitals for bond formation is : (1989 - 1 Mark)  
 (a)  $\text{H}\overset{*}{\text{C}}\text{OOH}$  (b)  $(\text{H}_2\text{N})_2\overset{*}{\text{C}}\text{O}$   
 (c)  $(\text{CH}_3)_3\overset{*}{\text{C}}\text{OH}$  (d)  $\text{CH}_3\overset{*}{\text{C}}\text{HO}$
25. Which of the following is paramagnetic? (1989 - 1 Mark)  
 (a)  $\text{O}_2^-$  (b)  $\text{CN}^-$  (c)  $\text{CO}$  (d)  $\text{NO}^+$
26. The type of hybrid orbitals used by the chlorine atom in  $\text{ClO}_2^-$  is (1992 - 1 Mark)  
 (a)  $sp^3$  (b)  $sp^2$   
 (c)  $sp$  (d) none of these
27. The maximum possible number of hydrogen bonds a water molecule can form is (1992 - 1 Mark)  
 (a) 2 (b) 4 (c) 3 (d) 1
28. The cyanide ion,  $\text{CN}^-$  and  $\text{N}_2$  are isoelectronic. But in contrast to  $\text{CN}^-$ ,  $\text{N}_2$  is chemically inert, because of (1992 - 1 Mark)  
 (a) low bond energy  
 (b) absence of bond polarity  
 (c) unsymmetrical electron distribution  
 (d) presence of more number of electrons in bonding orbitals
29. Pick out the isoelectronic structures from the following; (1993 - 1 Mark)  
 I.  $\text{CH}_3^+$  II.  $\text{H}_3\text{O}^+$   
 III.  $\text{NH}_3$  IV.  $\text{CH}_3^-$   
 (a) I and II (b) III and IV  
 (c) I and III (d) II, III and IV
30. Which one is most ionic : (1995S)  
 (a)  $\text{P}_2\text{O}_5$  (b)  $\text{CrO}_3$  (c)  $\text{MnO}$  (d)  $\text{Mn}_2\text{O}_7$
31. Number of paired electrons in  $\text{O}_2$  molecule is : (1995S)  
 (a) 7 (b) 8 (c) 16 (d) 14
32. Among the following species, identify the isostructural pairs. (1996 - 1 Mark)  
 $\text{NF}_3, \text{NO}_3^-, \text{BF}_3, \text{H}_3\text{O}^+, \text{HN}_3$   
 (a)  $[\text{NF}_3, \text{NO}_3^-]$  and  $[\text{BF}_3, \text{H}_3\text{O}^+]$   
 (b)  $[\text{NF}_3, \text{HN}_3]$  and  $[\text{NO}_3^-, \text{BF}_3]$   
 (c)  $[\text{NF}_3, \text{H}_3\text{O}^+]$  and  $[\text{NO}_3^-, \text{BF}_3]$   
 (d)  $[\text{NF}_3, \text{H}_3\text{O}^+]$  and  $[\text{HN}_3, \text{BF}_3]$
33. The number and type of bonds between two carbon atoms in  $\text{CaC}_2$  are : (1996 - 1 Mark)  
 (a) one sigma ( $\sigma$ ) and one pi ( $\pi$ ) bonds  
 (b) one sigma ( $\sigma$ ) and two pi ( $\pi$ ) bonds  
 (c) one sigma ( $\sigma$ ) and one and a half pi ( $\pi$ ) bonds  
 (d) one sigma ( $\sigma$ ) bond.
34. Which contains both polar and non-polar bonds?  
 (a)  $\text{NH}_4\text{Cl}$  (b)  $\text{HCN}$  (1997 - 1 Mark)  
 (c)  $\text{H}_2\text{O}_2$  (d)  $\text{CH}_4$
35. The critical temperature of water is higher than that of  $\text{O}_2$  because the  $\text{H}_2\text{O}$  molecule has (1997 - 1 Mark)  
 (a) fewer electrons than  $\text{O}_2$   
 (b) two covalent bonds  
 (c) V-shape (d) dipole moment.
36. Which one of the following compounds has  $sp^2$  hybridization? (1997 - 1 Mark)  
 (a)  $\text{CO}_2$  (b)  $\text{SO}_2$  (c)  $\text{N}_2\text{O}$  (d)  $\text{CO}$
37. The geometry and the type of hybrid orbital present about the central atom in  $\text{BF}_3$  is (1998 - 2 Marks)  
 (a) linear,  $sp$  (b) trigonal planar,  $sp^2$   
 (c) tetrahedral,  $sp^3$  (d) pyramidal,  $sp^3$ .
38. The correct order of increasing C — O bond length of  $\text{CO}$ ,  $\text{CO}_3^{2-}$ ,  $\text{CO}_2$ , is (1999 - 2 Marks)  
 (a)  $\text{CO}_3^{2-} < \text{CO}_2 < \text{CO}$  (b)  $\text{CO}_2 < \text{CO}_3^{2-} < \text{CO}$   
 (c)  $\text{CO} < \text{CO}_3^{2-} < \text{CO}_2$  (d)  $\text{CO} < \text{CO}_2 < \text{CO}_3^{2-}$
39. The geometry of  $\text{H}_2\text{S}$  and its dipole moment are (1999 - 2 Marks)  
 (a) angular and non-zero (b) angular and zero  
 (c) linear and non-zero (d) linear and zero

40. Molecular shapes of  $\text{SF}_4$ ,  $\text{CF}_4$  and  $\text{XeF}_4$  are (2000S)  
 (a) the same, with 2, 0 and 1 lone pairs of electrons respectively  
 (b) the same, with 1, 1 and 1 lone pairs of electrons respectively  
 (c) different, with 0, 1 and 2 lone pairs of electrons respectively  
 (d) different, with 1, 0 and 2 lone pairs of electrons respectively
41. The hybridisation of atomic orbitals of nitrogen in  $\text{NO}_2^+$ ,  $\text{NO}_3^-$  and  $\text{NH}_4^+$  are (2000S)  
 (a)  $sp$ ,  $sp^3$  and  $sp^2$  respectively  
 (b)  $sp$ ,  $sp^2$  and  $sp^3$  respectively  
 (c)  $sp^2$ ,  $sp$  and  $sp^3$  respectively  
 (d)  $sp^2$ ,  $sp^3$  and  $sp$  respectively
42. The common features among the species  $\text{CN}^-$ ,  $\text{CO}$  and  $\text{NO}^+$  are (2001S)  
 (a) bond order three and isoelectronic  
 (b) bond order three and weak field ligands  
 (c) bond order two and  $\pi$ -acceptors  
 (d) isoelectronic and weak field ligands
43. The correct order of hybridization of the central atom in the following species  $\text{NH}_3$ ,  $[\text{PtCl}_4]^{2-}$ ,  $\text{PCl}_5$  and  $\text{BCl}_3$  is (2001S)  
 (a)  $dsp^2$ ,  $dsp^3$ ,  $sp^2$  and  $sp^3$  (b)  $sp^3$ ,  $dsp^2$ ,  $dsp^3$ ,  $sp^2$   
 (c)  $dsp^2$ ,  $sp^2$ ,  $sp^3$ ,  $dsp^3$  (d)  $dsp^2$ ,  $sp^3$ ,  $sp^2$ ,  $dsp^3$
44. Specify the coordination geometry around and hybridisation of N and B atoms in a 1 : 1 complex of  $\text{BF}_3$  and  $\text{NH}_3$   
 (a) N : tetrahedral,  $sp^3$ ; B : tetrahedral,  $sp^3$  (2002S)  
 (b) N : pyramidal,  $sp^3$ ; B : pyramidal,  $sp^3$   
 (c) N : pyramidal,  $sp^3$ ; B : planar,  $sp^2$   
 (d) N : pyramidal,  $sp^3$ ; B : tetrahedral,  $sp^3$
45. Identify the least stable ion amongst the following : (2002S)  
 (a)  $\text{Li}^-$  (b)  $\text{Be}^-$  (c)  $\text{B}^-$  (d)  $\text{C}^-$
46. Which of the following molecular species has unpaired electron(s) ? (2002S)  
 (a)  $\text{N}_2$  (b)  $\text{F}_2$  (c)  $\text{O}_2^-$  (d)  $\text{O}_2^{2-}$
47. Which of the following are isoelectronic and isostructural?  $\text{NO}_3^-$ ,  $\text{CO}_3^{2-}$ ,  $\text{ClO}_3^-$ ,  $\text{SO}_3$  (2003S)  
 (a)  $\text{NO}_3^-$ ,  $\text{CO}_3^{2-}$  (b)  $\text{SO}_3$ ,  $\text{NO}_3^-$   
 (c)  $\text{ClO}_3^-$ ,  $\text{CO}_3^{2-}$  (d)  $\text{CO}_3^{2-}$ ,  $\text{SO}_3$
48. According to molecular orbital theory which of the following statement about the magnetic character and bond order is correct regarding  $\text{O}_2^+$  (2004S)  
 (a) Paramagnetic and Bond order  $< \text{O}_2$   
 (b) Paramagnetic and Bond order  $> \text{O}_2$   
 (c) Diamagnetic and Bond order  $< \text{O}_2$   
 (d) Diamagnetic and Bond order  $> \text{O}_2$
49. Which species has the maximum number of lone pair of electrons on the central atom? (2005S)  
 (a)  $[\text{ClO}_3]^-$  (b)  $\text{XeF}_4$  (c)  $\text{SF}_4$  (d)  $[\text{I}_3]^-$
50. Among the following, the paramagnetic compound is (2007)  
 (a)  $\text{Na}_2\text{O}_2$  (b)  $\text{O}_3$  (c)  $\text{N}_2\text{O}$  (d)  $\text{KO}_2$
51. The species having bond order different from that in  $\text{CO}$  is (2007)  
 (a)  $\text{NO}^-$  (b)  $\text{NO}^+$  (c)  $\text{CN}^-$  (d)  $\text{N}_2$
52. Assuming that Hund's rule is violated, the bond order and magnetic nature of the diatomic molecule  $\text{B}_2$  is (2010)  
 (a) 1 and diamagnetic (b) 0 and diamagnetic  
 (c) 1 and paramagnetic (d) 0 and paramagnetic
53. The species having pyramidal shape is : (2010)  
 (a)  $\text{SO}_3$  (b)  $\text{BrF}_3$  (c)  $\text{SiO}_3^{2-}$  (d)  $\text{OSF}_2$
54. Geometrical shapes of the complexes formed by the reaction of  $\text{Ni}^{2+}$  with  $\text{Cl}^-$ ,  $\text{CN}^-$  and  $\text{H}_2\text{O}$ , respectively, are (2011)  
 (a) octahedral, tetrahedral and square planar  
 (b) tetrahedral, square planar and octahedral  
 (c) square planar, tetrahedral and octahedral  
 (d) octahedral, square planar and octahedral
55. Assuming  $2s-2p$  mixing is NOT operative, the paramagnetic species among the following is (JEE Adv. 2014)  
 (a)  $\text{Be}_2$  (b)  $\text{B}_2$  (c)  $\text{C}_2$  (d)  $\text{N}_2$
56. The geometries of the ammonia complexes of  $\text{Ni}^{2+}$ ,  $\text{Pt}^{2+}$  and  $\text{Zn}^{2+}$  respectively, are (JEE Adv. 2016)  
 (a) octahedral, square planar and tetrahedral  
 (b) square planar, octahedral and tetrahedral  
 (c) tetrahedral, square planar and octahedral  
 (d) octahedral, tetrahedral and square planar

### D MCQs with One or More Than One Correct

1.  $\text{CO}_2$  is isostructural with : (1986 - 1 Mark)  
 (a)  $\text{HgCl}_2$  (b)  $\text{SnCl}_2$  (c)  $\text{C}_2\text{H}_2$  (d)  $\text{NO}_2$
2. The linear structure is assumed by : (1991 - 1 Mark)  
 (a)  $\text{SnCl}_2$  (b)  $\text{NCO}^-$  (c)  $\text{CS}_2$  (d)  $\text{NO}_2^+$
3. Which of the following have identical bond order? (1992 - 1 Mark)  
 (a)  $\text{CN}^-$  (b)  $\text{O}_2^-$  (c)  $\text{NO}^+$  (d)  $\text{CN}^+$
4. The molecules that will have dipole moment are (1992 - 1 Mark)  
 (a) 2,2-dimethylpropane (b) trans-2-pentene  
 (c) cis-3-hexene (d) 2,2,3,3-tetramethylbutane
5. The compound(s) with TWO lone pairs of electrons on the central atom is(are) (JEE Adv. 2016)  
 (a)  $\text{BrF}_5$  (b)  $\text{ClF}_3$  (c)  $\text{XeF}_4$  (d)  $\text{SF}_4$
6. According to Molecular Orbital Theory, (JEE Adv. 2016)  
 (a)  $\text{C}_2^{2-}$  is expected to be diamagnetic  
 (b)  $\text{O}_2^{2+}$  is expected to have a longer bond length than  $\text{O}_2$   
 (c)  $\text{N}_2^+$  and  $\text{N}_2^-$  have the same bond order  
 (d)  $\text{He}_2^+$  has the same energy as two isolated He atoms

### E Subjective Problems

1. Water is liquid while  $\text{H}_2\text{S}$  is a gas at room temperature. (1978)
2. Write the Lewis dot structural formula for each of the following. Give, also, the formula of a neutral molecule, which has the same geometry and the same arrangement of the bonding electrons as in each of the following. An example is

given below in the case of  $\text{H}_3\text{O}^+$  :

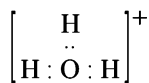

Lewis dot structure

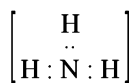

Neutral molecule

(i)  $\text{O}_2^{2-}$ ; (ii)  $\text{CO}_3^{2-}$ ; (iii)  $\text{CN}^-$ ; (iv)  $\text{NCS}^-$

(1983 - 1 × 4 = 4 Marks)

3. How many sigma bonds and how many pi-bonds are present in a benzene molecule? (1985 - 1 Mark)

4. Write the Lewis dot structure of the following :



(1986 - 1 Mark)

5. Arrange the following :

(i)  $\text{N}_2, \text{O}_2, \text{F}_2, \text{Cl}_2$  in increasing order of bond dissociation energy. (1988 - 1 Mark)

(ii) Increasing strength of hydrogen bonding (X-H-X) : (1991 - 1 Mark)

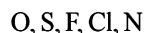

(iii) In the decreasing order of the O-O bond length present in them (2004 - 4 Marks)

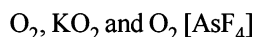

6. The dipole moment of KCl is  $3.336 \times 10^{-29}$  Coulomb meters which indicates that it is a highly polar molecule. The interatomic distance between  $\text{K}^+$  and  $\text{Cl}^-$  in this molecule is  $2.6 \times 10^{-10}$  m. Calculate the dipole moment of KCl molecule if there were opposite charges of one fundamental unit located at each nucleus. Calculate the percentage ionic character of KCl. (1993 - 2 Marks)

7. Using the VSEPR theory, identify the type of hybridization and draw the structure of  $\text{OF}_2$ . What are the oxidation states of O and F? (1994 - 3 Marks)

8. A compound of vanadium has a magnetic moment of 1.73 BM. Work out the electronic configuration of the vanadium ion in the compound. (1997 - 2 Marks)

9. Interpret the non-linear shape of  $\text{H}_2\text{S}$  molecule and non-planar shape of  $\text{PCl}_3$  using valence shell electron pair repulsion (VSEPR) theory. (Atomic numbers : H = 1, P = 15, S = 16, Cl = 17.) (1998 - 4 Marks)

10. Write the M.O. electron distribution of  $\text{O}_2$ . Specify its bond order and magnetic property. (2000 - 3 Marks)

11. Using VSEPR theory, draw the shape of  $\text{PCl}_5$  and  $\text{BrF}_5$ . (2003 - 2 Marks)

12. Draw the structure of  $\text{XeF}_4$  and  $\text{OSF}_4$  according to VSEPR theory, clearly indicating the state of hybridisation of the central atom and lone pair of electrons (if any) on the central atom. (2004 - 2 Marks)

## F Match the Following

1. Match the orbital overlap figures shown in List-I with the description given in List-II and select the correct answer using the code given below the lists. (JEE Adv. 2014)

### List-I

P.

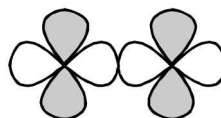

Q.

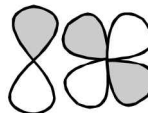

R.

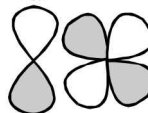

S.

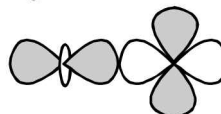

### List-II

1.  $p-d\pi$  antibonding

2.  $d-d\sigma$  bonding

3.  $p-d\pi$  bonding

4.  $d-d\sigma$  antibonding

Code:

	P	Q	R	S
(a)	2	1	3	4
(b)	4	3	1	2
(c)	2	3	1	4
(d)	4	1	3	2

## H Assertion & Reason Type Questions

1. Read the following Assertion and Reason and answer as per the options given below : (1998 - 2 Marks)

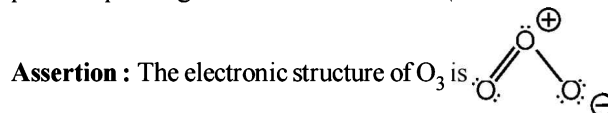

**Reason :** structure is not allowed because octet around O cannot be expanded.

- (a) If both *assertion* and *reason* are correct, and *reason* is the correct explanation of the *assertion*.  
 (b) If both *assertion* and *reason* are correct, but *reason* is not the correct explanation of the *assertion*.  
 (c) If *assertion* is correct but *reason* is incorrect.  
 (d) If *assertion* is incorrect but *reason* is correct.
2. Read the following Assertion and Reason and answer as per the options given below : (1998 - 2 Marks)

**Assertion :** LiCl is predominantly a covalent compound.

**Reason :** Electronegativity difference between Li and Cl is too small.

- (a) If both *assertion* and *reason* are correct, and *reason* is the correct explanation of the *assertion*.  
 (b) If both *assertion* and *reason* are correct, but *reason* is not the correct explanation of the *assertion*.  
 (c) If *assertion* is correct but *reason* is incorrect.  
 (d) If *assertion* is incorrect but *reason* is correct.

## I Integer Value Correct Type

1. Based on VSEPR theory, the number of 90 degree F-Br-F angles in  $\text{BrF}_5$  is (2010)  
 2. The total number of lone-pairs of electrons in melamine is (JEE Adv. 2013)

3. A list of species having the formula  $XZ_4$  is given below.  $XeF_4$ ,  $SF_4$ ,  $SiF_4$ ,  $BF_4^-$ ,  $BrF_4^-$ ,  $[Cu(NH_3)_4]^{2+}$ ,  $[FeCl_4]^{2-}$ ,  $[CoCl_4]^{2-}$  and  $[PtCl_4]^{2-}$ .  
Defining shape on the basis of the location of X and Z atoms, the total number of species having a square planar shape is  
(JEE Adv. 2014)
4. Among the triatomic molecules/ions,  $BeCl_2$ ,  $N_3^-$ ,  $N_2O$ ,  $NO_2^+$ ,  $O_3$ ,  $SCl_2$ ,  $ICl_2^-$ ,  $I_3^-$  and  $XeF_2$ , the total number of linear molecule(s)/ion(s) where the hybridization of the central atom does not have contribution from the d-orbital(s) is  
[Atomic number : S = 16, Cl = 17, I = 53 and Xe = 54]  
(JEE Adv. 2015)

## Section-B

## JEE Main / AIEEE

1. In which of the following species the interatomic bond angle is  $109^\circ 28'$ ? [2002]  
(a)  $NH_3, (BF_4)^-$  (b)  $(NH_4)^+, BF_3$   
(c)  $NH_3, BF_4$  (d)  $(NH_2)^-, BF_3$
2. Which of the following are arranged in an increasing order of their bond strengths? [2002]  
(a)  $O_2^- < O_2 < O_2^+ < O_2^{2-}$  (b)  $O_2^{2-} < O_2^- < O_2 < O_2^+$   
(c)  $O_2^- < O_2^{2-} < O_2 < O_2^+$  (d)  $O_2^+ < O_2 < O_2^- < O_2^{2-}$
3. Hybridisation of the underline atom changes in: [2002]  
(a) Al $H_3$  changes to  $AlH_4^-$   
(b) H $_2$ O changes to  $H_3O^+$   
(c) N $H_3$  changes to  $NH_4^+$   
(d) in all cases
4. An ether is more volatile than an alcohol having the same molecular formula. This is due to [2003]  
(a) alcohols having resonance structures  
(b) inter-molecular hydrogen bonding in ethers  
(c) inter-molecular hydrogen bonding in alcohols  
(d) dipolar character of ethers
5. Which one of the following pairs of molecules will have permanent dipole moments for both members? [2003]  
(a)  $NO_2$  and  $CO_2$  (b)  $NO_2$  and  $O_3$   
(c)  $SiF_4$  and  $CO_2$  (d)  $SiF_4$  and  $NO_2$
6. Which one of the following compounds has the smallest bond angle in its molecule? [2003]  
(a)  $OH_2$  (b)  $SH_2$  (c)  $NH_3$  (d)  $SO_2$
7. The pair of species having identical shapes for molecules of both species is [2003]  
(a)  $XeF_2, CO_2$  (b)  $BF_3, PCl_3$   
(c)  $PF_5, IF_5$  (d)  $CF_4, SF_4$
8. The correct order of bond angles (smallest first) in  $H_2S$ ,  $NH_3$ ,  $BF_3$  and  $SiH_4$  is [2004]  
(a)  $H_2S < NH_3 < SiH_4 < BF_3$  (b)  $NH_3 < H_2S < SiH_4 < BF_3$   
(c)  $H_2S < SiH_4 < NH_3 < BF_3$  (d)  $H_2S < NH_3 < BF_3 < SiH_4$
9. The bond order in NO is 2.5 while that in  $NO^+$  is 3. Which of the following statements is true for these two species? [2004]  
(a) Bond length in  $NO^+$  is equal to that in NO  
(b) Bond length in NO is greater than in  $NO^+$   
(c) Bond length in  $NO^+$  is greater than in NO  
(d) Bond length is unpredictable
10. The states of hybridization of boron and oxygen atoms in boric acid ( $H_3BO_3$ ) are respectively [2004]  
(a)  $sp^3$  and  $sp^2$  (b)  $sp^2$  and  $sp^3$   
(c)  $sp^2$  and  $sp^2$  (d)  $sp^3$  and  $sp^3$
11. Which one of the following has the regular tetrahedral structure? [2004]  
(a)  $BF_4^-$  (b)  $SF_4$   
(c)  $XeF_4$  (d)  $[Ni(CN)_4]^{2-}$   
(Atomic nos. : B = 5, S = 16, Ni = 28, Xe = 54)
12. The maximum number of  $90^\circ$  angles between bond pair-bond pair of electrons is observed in [2004]  
(a)  $dsp^2$  hybridization  
(b)  $sp^3d$  hybridization  
(c)  $dsp^3$  hybridization  
(d)  $sp^3d^2$  hybridization
13. Lattice energy of an ionic compound depends upon [2005]  
(a) Charge on the ion and size of the ion  
(b) Packing of ions only  
(c) Size of the ion only  
(d) Charge on the ion only
14. Which of the following molecules/ions does not contain unpaired electrons? [2006]  
(a)  $N_2^+$  (b)  $O_2$  (c)  $O_2^{2-}$  (d)  $B_2$
15. In which of the following molecules/ions are all the bonds not equal? [2006]  
(a)  $XeF_4$  (b)  $BF_4^-$   
(c)  $SF_4$  (d)  $SiF_4$
16. The decreasing values of bond angles from  $NH_3$  ( $106^\circ$ ) to  $SbH_3$  ( $101^\circ$ ) down group-15 of the periodic table is due to [2006]  
(a) decreasing lp-bp repulsion  
(b) decreasing electronegativity  
(c) increasing bp-bp repulsion  
(d) increasing p-orbital character in  $sp^3$
17. Which of the following species exhibits the diamagnetic behaviour? [2007]  
(a) NO (b)  $O_2^{2-}$   
(c)  $O_2^+$  (d)  $O_2$
18. The charge/size ratio of a cation determines its polarizing power. Which one of the following sequences represents the increasing order of the polarizing power of the cationic

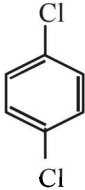
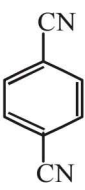
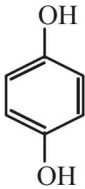
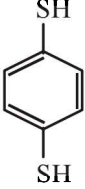
- species,  $K^+$ ,  $Ca^{2+}$ ,  $Mg^{2+}$ ,  $Be^{2+}$ ? [2007]
- (a)  $Ca^{2+} < Mg^{2+} < Be^+ < K^+$   
 (b)  $Mg^{2+} < Be^{2+} < K^+ < Ca^{2+}$   
 (c)  $Be^{2+} < K^+ < Ca^{2+} < Mg^{2+}$   
 (d)  $K^+ < Ca^{2+} < Mg^{2+} < Be^{2+}$ .
19. In which of the following ionization processes, the bond order has increased and the magnetic behaviour has changed? [2007]
- (a)  $N_2 \rightarrow N_2^+$  (b)  $C_2 \rightarrow C_2^+$   
 (c)  $NO \rightarrow NO^+$  (d)  $O_2 \rightarrow O_2^+$ .
20. Which of the following hydrogen bonds is the strongest? [2007]
- (a)  $O-H \cdots F$  (b)  $O-H \cdots H$   
 (c)  $F-H \cdots F$  (d)  $O-H \cdots O$ .
21. Which one of the following pairs of species have the same bond order? [2008]
- (a)  $CN^-$  and  $NO^+$  (b)  $CN^-$  and  $CN^+$   
 (c)  $O_2^-$  and  $CN^-$  (d)  $NO^+$  and  $CN^+$
22. The bond dissociation energy of  $B-F$  in  $BF_3$  is  $646 \text{ kJ mol}^{-1}$  whereas that of  $C-F$  in  $CF_4$  is  $515 \text{ kJ mol}^{-1}$ . The correct reason for higher  $B-F$  bond dissociation energy as compared to that of  $C-F$  is [2008]
- (a) stronger  $\sigma$  bond between B and F in  $BF_3$  as compared to that between C and F in  $CF_4$ .  
 (b) significant  $p\pi - p\pi$  interaction between B and F in  $BF_3$  whereas there is no possibility of such interaction between C and F in  $CF_4$ .  
 (c) lower degree of  $p\pi - p\pi$  interaction between B and F in  $BF_3$  than that between C and F in  $CF_4$ .  
 (d) smaller size of B-atom as compared to that of C-atom.
23. Using MO theory, predict which of the following species has the shortest bond length? [2008]
- (a)  $O_2^+$  (b)  $O_2^-$  (c)  $O_2^{2-}$  (d)  $O_2^{2+}$
24. Among the following the maximum covalent character is shown by the compound [2011]
- (a)  $FeCl_2$  (b)  $SnCl_2$  (c)  $AlCl_3$  (d)  $MgCl_2$
25. The hybridization of orbitals of N atom in  $NO_3^-$ ,  $NO_2^+$  and  $NH_4^+$  are respectively: [2011]
- (a)  $sp$ ,  $sp^2$ ,  $sp^3$  (b)  $sp^2$ ,  $sp$ ,  $sp^3$   
 (c)  $sp$ ,  $sp^3$ ,  $sp^2$  (d)  $sp^2$ ,  $sp^3$ ,  $sp$
26. The structure of  $IF_7$  is [2011]
- (a) square pyramidal (b) trigonal bipyramidal  
 (c) octahedral (d) pentagonal bipyramidal
27. Ortho-Nitrophenol is less soluble in water than *p*- and *m*-Nitrophenols because: [2012]
- (a) *o*-Nitrophenol is more volatile steam than those of *m*- and *p*-isomers.  
 (b) *o*-Nitrophenol shows intramolecular H-bonding  
 (c) *o*-Nitrophenol shows intermolecular H-bonding  
 (d) Melting point of *o*-Nitrophenol is lower than those of *m*- and *p*-isomers.
28. In which of the following pairs the two species are not isostructural? [2012]
- (a)  $CO_3^{2-}$  and  $NO_3^-$  (b)  $PCl_4^+$  and  $SiCl_4$   
 (c)  $PF_5$  and  $BrF_5$  (d)  $AlF_6^{3-}$  and  $SF_6$
29. Which one of the following molecules is expected to exhibit diamagnetic behaviour? [JEE M 2013]
- (a)  $C_2$  (b)  $N_2$   
 (c)  $O_2$  (d)  $S_2$
30. Which of the following is the wrong statement? [JEE M 2013]
- (a)  $ONCl$  and  $ONO^-$  are not isoelectronic.  
 (b)  $O_3$  molecule is bent  
 (c) Ozone is violet-black in solid state  
 (d) Ozone is diamagnetic gas.
31. In which of the following pairs of molecules/ions, both the species are not likely to exist? [JEE M 2013]
- (a)  $H_2^+$ ,  $He_2^{2-}$  (b)  $H_2^-$ ,  $He_2^{2-}$   
 (c)  $H_2^{2+}$ ,  $He_2$  (d)  $H_2^-$ ,  $He_2^{2+}$
32. Stability of the species  $Li_2$ ,  $Li_2^-$  and  $Li_2^+$  increases in the order of: [JEE M 2013]
- (a)  $Li_2 < Li_2^+ < Li_2^-$  (b)  $Li_2^- < Li_2^+ < Li_2$   
 (c)  $Li_2 < Li_2^- < Li_2^+$  (d)  $Li_2^- < Li_2 < Li_2^+$
33. For which of the following molecule significant  $\mu \neq 0$ ? [JEE M 2014]
- (i)  (ii)   
 (iii)  (iv) 
- (a) Only (i) (b) (i) and (ii)  
 (c) Only (iii) (d) (iii) and (iv)
34. The species in which the N atom is in a state of *sp* hybridization is: [JEE M 2016]
- (a)  $NO_3^-$  (b)  $NO_2$   
 (c)  $NO_2^+$  (d)  $NO_2^-$



## CHAPTER

## 5

## States of Matter

## Section-A

## JEE Advanced/ IIT-JEE

## A Fill in the Blanks

- The total energy of one mole of an ideal monatomic gas at 27°C is ..... calories. (1984 - 1 Mark)
- $C_p - C_v$  for an ideal gas is ..... (1984 - 1 Mark)
- The rate of diffusion of gas is ..... proportional to both ..... and square root of molecular mass. (1986 - 1 Mark)
- The value of  $PV$  for 5.6 litres of an ideal gas is .....  $RT$ , at N.T.P. (1987 - 1 Mark)
- Eight gram each of oxygen and hydrogen at 27°C will have the total kinetic energy in the ratio of ..... (1989 - 1 Mark)

## B True / False

- Kinetic energy of a molecule is zero at 0°C. (1985 - ½ Mark)
- A gas in a closed container will exert much higher pressure due to gravity at the bottom than at the top. (1985 - ½ Mark)
- In the van der Waal's equation  $\left(P + \frac{n^2a}{V^2}\right)(V - nb) = nRT$  the constant 'a' reflects the actual volume of the gas molecules. (1993 - 1 Mark)
- A mixture of ideal gases is cooled upto liquid helium temperature (4.22 K) to form an ideal solution. (1996 - 1 Mark)

## C MCQs with One Correct Answer

- Equal weights of methane and oxygen are mixed in an empty container at 25°C. The fraction of the total pressure exerted by oxygen is (1981 - 1 Mark)
  - $\frac{1}{3}$
  - $\frac{1}{2}$
  - $\frac{2}{3}$
  - $\frac{1}{3} \times \frac{273}{298}$
- The temperature at which a real gas obeys the ideal gas laws over a wide range of pressure is (1981 - 1 Mark)

- Critical temperature
  - Boyle temperature
  - Inversion temperature
  - Reduced temperature
- The ratio of root mean square velocity to average velocity of a gas molecule at a particular temperature is (1981 - 1 Mark)
    - 1.086 : 1
    - 1 : 1.086
    - 2 : 1.086
    - 1.086 : 2
  - Helium atom is two times heavier than a hydrogen molecule. At 298 K, the average kinetic energy of a helium atom is (1982 - 1 Mark)
    - two times that of a hydrogen molecule.
    - same as that of a hydrogen molecule.
    - four times that of a hydrogen molecule.
    - half that of a hydrogen molecule.
  - Equal weights of methane and hydrogen are mixed in an empty container at 25°C. The fraction of the total pressure exerted by hydrogen is : (1984 - 1 Mark)
    - $\frac{1}{2}$
    - $\frac{8}{9}$
    - $\frac{1}{9}$
    - $\frac{16}{17}$
  - Rate of diffusion of a gas is : (1985 - 1 Mark)
    - directly proportional to its density.
    - directly proportional to its molecular weight.
    - directly proportional to the square root of its molecular weight.
    - inversely proportional to the square root of its molecular weight.
  - The average velocity of an ideal gas molecule at 27°C is 0.3 m/sec. The average velocity at 927°C will be: (1986 - 1 Mark)
    - 0.6 m/sec
    - 0.3 m/sec
    - 0.9 m/sec
    - 3.0 m/sec
  - In van der Waals equation of state for a non-ideal gas, the term that accounts for intermolecular forces is (1988 - 1 Mark)
    - $(V - b)$
    - $RT$
    - $\left(P + \frac{a}{V^2}\right)$
    - $(RT)^{-1}$

9. A bottle of dry ammonia and a bottle of dry hydrogen chloride connected through a long tube are opened simultaneously at both ends the white ammonium chloride ring first formed will be (1988 - 1 Mark)
- at the centre of the tube.
  - near the hydrogen chloride bottle.
  - near the ammonia bottle.
  - throughout the length of the tube.
10. The values of van der Waals constant 'a' for the gases  $O_2$ ,  $N_2$ ,  $NH_3$  and  $CH_4$  are 1.360, 1.390, 4.170 and  $2.253 \text{ L}^2 \text{ atm mol}^{-2}$  respectively. The gas which can most easily be liquified is: (1989 - 1 Mark)
- $O_2$
  - $N_2$
  - $NH_3$
  - $CH_4$
11. The density of neon will be highest at (1990 - 1 Mark)
- S.T.P.
  - $0^\circ\text{C}$ , 2 atm
  - $273^\circ\text{C}$ , 1 atm.
  - $273^\circ\text{C}$ , 2 atm.
12. The rate of diffusion of methane at a given temperature is twice that of a gas X. The molecular weight of X is (1990 - 1 Mark)
- 64.0
  - 32.0
  - 4.0
  - 8.0
13. According to kinetic theory of gases, for a diatomic molecule (1991 - 1 Mark)
- the pressure exerted by the gas is proportional to mean velocity of the molecule
  - the pressure exerted by the gas is proportional to the root mean velocity of the molecule
  - the root mean square velocity of the molecule is inversely proportional to the temperature
  - the mean translational kinetic energy of the molecule is proportional to the absolute temperature.
14. At constant volume, for a fixed number of moles of a gas the pressure of the gas increases with rise in temperature due to (1992 - 1 Mark)
- Increase in average molecular speed
  - Increased rate of collisions amongst molecules
  - Increase in molecular attraction
  - Decrease in mean free path
15. Longest mean free path stands for : (1995S)
- $H_2$
  - $N_2$
  - $O_2$
  - $Cl_2$
16. Arrange the van der Waals constant for the gases : (1995S)
- |                     |           |
|---------------------|-----------|
| I $C_6H_6(g)$       | A. 0.217  |
| II $C_6H_5.CH_3(g)$ | B. 5.464  |
| III $Ne(g)$         | C. 18.000 |
| IV $H_2O(g)$        | D. 24.060 |
- I-A, II-D, III-C, IV-B
  - I-D, II-A, III-B, IV-C
  - I-C, II-D, III-A, IV-B
  - I-B, II-C, III-A, IV-D
17. The ratio between the root mean square speed of  $H_2$  at 50 K and that of  $O_2$  at 800 K is, (1996 - 1 Mark)
- 4
  - 2
  - 1
  - 1/4
18. X mL of  $H_2$  gas effuses through a hole in a container in 5 seconds. The time taken for the effusion of the same volume of the gas specified below under identical conditions is : (1996 - 1 Mark)
- 10 seconds : He
  - 20 seconds :  $O_2$
  - 25 seconds : CO
  - 55 seconds :  $CO_2$
19. One mole of  $N_2O_4(g)$  at 300 K is kept in a closed container under one atmosphere. It is heated to 600 K when 20% by mass of  $N_2O_4(g)$  decomposes to  $NO_2(g)$ . The resultant pressure is : (1996 - 1 Mark)
- 1.2 atm
  - 2.4 atm
  - 2.0 atm
  - 1.0 atm
20. The compressibility factor for an ideal gas is (1997 - 1 Mark)
- 1.5
  - 1.0
  - 2.0
  - $\infty$
21. A gas will approach ideal behaviour at (1999 - 2 Marks)
- low temperature and low pressure.
  - low temperature and high pressure.
  - high temperature and low pressure.
  - high temperature and high pressure.
22. The rms velocity of hydrogen is  $\sqrt{7}$  times the rms velocity of nitrogen. If T is the temperature of the gas, then (2000S)
- $T(H_2) = T(N_2)$
  - $T(H_2) > T(N_2)$
  - $T(H_2) < T(N_2)$
  - $T(H_2) = \sqrt{7} T(N_2)$
23. The compressibility of a gas is less than unity at STP. Therefore, (2000S)
- $V_m > 22.4$  litres
  - $V_m < 22.4$  litres
  - $V_m = 22.4$  litres
  - $V_m = 44.8$  litres
24. At  $100^\circ\text{C}$  and 1 atm, if the density of liquid water is  $1.0 \text{ g cm}^{-3}$  and that of water vapour is  $0.0006 \text{ g cm}^{-3}$ , then the volume occupied by water molecules in 1 litre of steam at that temperature is (2000S)
- $6 \text{ cm}^3$
  - $60 \text{ cm}^3$
  - $0.6 \text{ cm}^3$
  - $0.06 \text{ cm}^3$
25. The root mean square velocity of an ideal gas at constant pressure varies with density (d) as (2001S)
- $d^2$
  - d
  - $\sqrt{d}$
  - $1/\sqrt{d}$
26. Which of the following volume (V) - temperature (T) plots represents the behaviour of one mole of an ideal gas at one atmospheric pressure ? (2002S)

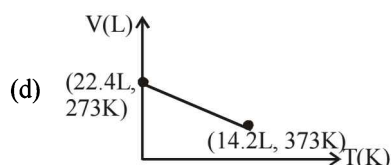
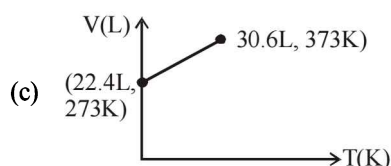
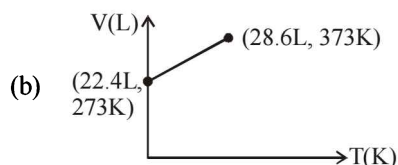
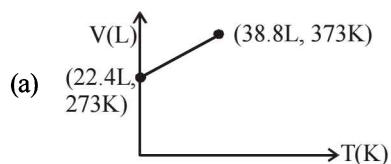

27. When the temperature is increased, surface tension of water (2002S)

- (a) increases  
(b) decreases  
(c) remains constant  
(d) shows irregular behaviour

28. Positive deviation from ideal behaviour takes place because of (2003S)

- (a) Molecular interaction between atoms and  $PV/nRT > 1$   
(b) Molecular interaction between atoms and  $PV/nRT < 1$   
(c) Finite size of atoms and  $PV/nRT > 1$   
(d) Finite size of atoms and  $PV/nRT < 1$

29. The root mean square velocity of one mole of a monoatomic gas having molar mass  $M$  is  $u_{r.m.s.}$ . The relation between the average kinetic energy ( $E$ ) of the gas and  $u_{r.m.s.}$  is (2004S)

- (a)  $u_{r.m.s.} = \sqrt{\frac{3E}{2M}}$       (b)  $u_{r.m.s.} = \sqrt{\frac{2E}{3M}}$   
(c)  $u_{r.m.s.} = \sqrt{\frac{2E}{M}}$       (d)  $u_{r.m.s.} = \sqrt{\frac{E}{3M}}$

30. The ratio of the rate of diffusion of helium and methane under identical condition of pressure and temperature will be (2005S)

- (a) 4      (b) 2  
(c) 1      (d) 0.5

31. When one mole of monoatomic ideal gas at  $T$  K undergoes adiabatic change under a constant external pressure of 1 atm volume changes from 1 litre to 2 litre. The final temperature in Kelvin would be (2005S)

- (a)  $\frac{T}{2^{(2/3)}}$       (b)  $T + \frac{2}{3} \times 0.0821$   
(c)  $T$       (d)  $T - \frac{2}{3} \times 0.0821$

32. A mono-atomic ideal gas undergoes a process in which the ratio of  $P$  to  $V$  at any instant is constant and equals to 1. What is the molar heat capacity of the gas

- (a)  $\frac{3R}{2}$       (b)  $2R$  (2006 - 3M; -1)  
(c) 0      (d)  $\frac{5R}{2}$

33. The term that corrects for the attractive forces present in a real gas in the van der Waals equation is

- (a)  $nb$       (b)  $\frac{an^2}{V^2}$  (2009 - 3M; -1)  
(c)  $-\frac{an^2}{V^2}$       (d)  $-nb$

34. For one mole of a van der Waal's gas when  $b = 0$  and  $T = 300$  K, the  $PV$  vs,  $1/V$  plot is shown below. The value of the van der Waal's constant  $a$  (atm. liter<sup>2</sup> mol<sup>-2</sup>) is : (2012)

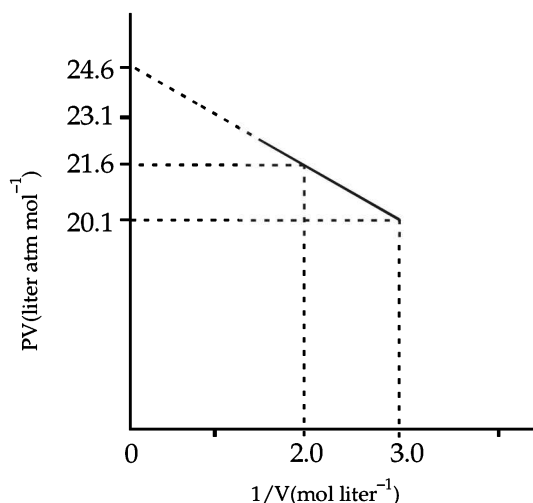

- (a) 1.0      (c) 4.5  
(b) 1.5      (d) 3.0

35. The qualitative sketches I, II and III given below show the variation of surface tension with molar concentration of three different aqueous solutions of KCl, CH<sub>3</sub>OH and CH<sub>3</sub>(CH<sub>2</sub>)<sub>11</sub>OSO<sub>3</sub><sup>-</sup> Na<sup>+</sup> at room temperature. The correct assignment of the sketches is (JEE Adv. 2016)

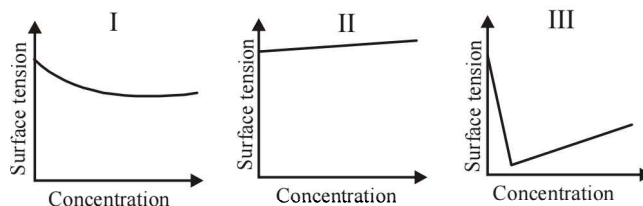

- (a) I : KCl    II : CH<sub>3</sub>OH    III : CH<sub>3</sub>(CH<sub>2</sub>)<sub>11</sub>OSO<sub>3</sub><sup>-</sup> Na<sup>+</sup>  
(b) I : CH<sub>3</sub>(CH<sub>2</sub>)<sub>11</sub>OSO<sub>3</sub><sup>-</sup> Na<sup>+</sup>    II : CH<sub>3</sub>OH    III : KCl  
(c) I : KCl    II : CH<sub>3</sub>(CH<sub>2</sub>)<sub>11</sub>OSO<sub>3</sub><sup>-</sup> Na<sup>+</sup>    III : CH<sub>3</sub>OH  
(d) I : CH<sub>3</sub>OH    II : KCl    III : CH<sub>3</sub>(CH<sub>2</sub>)<sub>11</sub>OSO<sub>3</sub><sup>-</sup> Na<sup>+</sup>

**D MCQs with One or More Than One Correct**

1. When an ideal gas undergoes unrestrained expansion, no cooling occurs because the molecules : (1984 - 1 Mark)
- are above the inversion temperature
  - exert no attractive forces on each other
  - do work equal to loss in kinetic energy
  - collide without loss of energy
2. If a gas is expanded at constant temperature :
- the pressure decreases (1986 - 1 Mark)
  - the kinetic energy of the molecules remains the same
  - the kinetic energy of the molecules decreases
  - the number of molecules of the gas increases
3. Equal weights of ethane and hydrogen are mixed in an empty container at 25°C. The fraction of the total pressure exerted by hydrogen is (1993 - 1 Mark)
- 1 : 2
  - 1 : 1
  - 1 : 16
  - 15 : 16
4. According to Graham's law, at a given temperature the ratio of the rates of diffusion  $r_A/r_B$  of gases A and B is given by (1998 - 2 Marks)
- $(P_A/P_B)(M_A/M_B)^{1/2}$
  - $(M_A/M_B)(P_A/P_B)^{1/2}$
  - $(P_A/P_B)(M_B/M_A)^{1/2}$
  - $(M_A/M_B)(P_B/P_A)^{1/2}$
- (Where P and M are pressures and molecular weights of gases A and B respectively.)
5. Refer to the figure given : (2006 - 5M; -1)  
Which of the following statements is wrong?

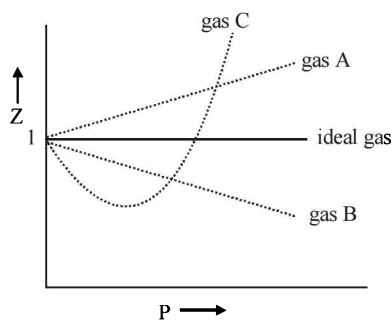

- For gas A,  $a=0$  and Z will linearly depend on pressure
  - For gas B,  $b=0$  and Z will linearly depend on pressure
  - Gas C is a real gas and we can find 'a' and 'b' if intersection data is given
  - All van der Waal gases will behave like gas C and give positive slope at high pressure
6. A gas described by van der Waals equation – (2008- 1 Mark)
- behave similar to an ideal gas in the limit of large molar volumes
  - behaves similar to an ideal gas is in limit of large pressures

- is characterised by van der Waals coefficients that are dependent on the identity of the gas but are independent of the temperature.
  - has the pressure that is lower than the pressure exerted by the same gas behaving ideally
7. According to kinetic theory of gases (2011)
- collisions are always elastic
  - heavier molecules transfer more momentum to the wall of the container
  - only a small number of molecules have very high velocity
  - between collisions, the molecules move in straight lines with constant velocities
8. One mole of a monoatomic real gas satisfies the equation  $p(V - b) = RT$  where b is a constant. The relationship of interatomic potential  $V(r)$  and interatomic distance r for the gas is given by (JEE Adv. 2015)

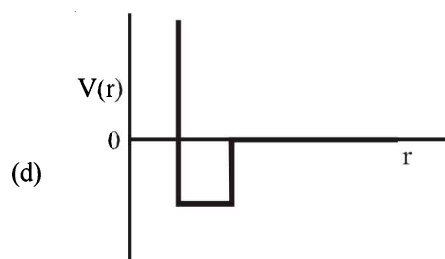
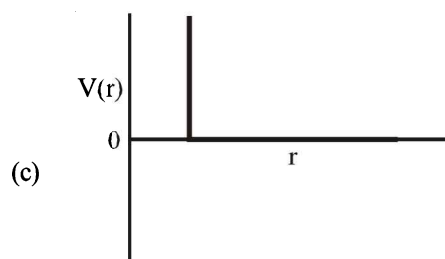
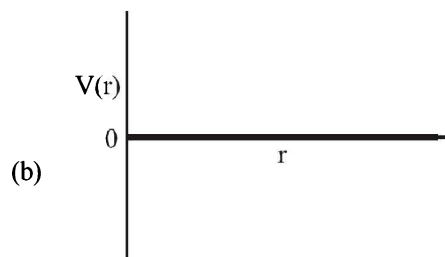
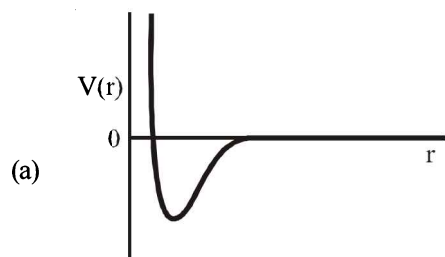

## E Subjective Problems

- Calculate density of  $\text{NH}_3$  at  $30^\circ\text{C}$  and 5 atm pressure. (1978)
- 3.7 g of a gas at  $25^\circ\text{C}$  occupied the same volume as 0.184g of hydrogen at  $17^\circ\text{C}$  and at the same pressure. What is the molecular weight of the gas? (1979)
- A straight glass tube has two inlets  $X$  and  $Y$  at two ends. The length of tube is 200 cm.  $\text{HCl}$  gas through inlets  $X$  and  $\text{NH}_3$  gas through inlet  $Y$  are allowed to enter the tube at the same time. What fumes appear at point  $P$  inside the tube. Find distance of  $P$  from  $X$ . (1980)
- 1 litre of mixture of  $\text{CO}$  and  $\text{CO}_2$  is taken. The mixture is passed through a tube containing red hot charcoal. The volume now becomes 1.6 litre. The volumes are measured under the same conditions. Find the composition of mixture by volume. (1980)
- At room temperature, ammonia gas at 1 atm pressure and hydrogen chloride gas at  $P$  atm pressure are allowed to effuse through identical pin holes from opposite ends of a glass tube of one metre length and of uniform cross-section. Ammonium chloride is first formed at a distance of 60 cm from the end through which  $\text{HCl}$  gas is sent in. What is the value of  $P$ ? (1982 - 4 Marks)
- Calculate the average of kinetic energy, in Joules of the molecules in 8.0 g of methane at  $27^\circ\text{C}$ . (1982 - 2 Marks)
- Oxygen is present in 1 litre flask at a pressure of  $7.6 \times 10^{-10}$  mm of Hg. Calculate the number of oxygen molecules in the flask at  $0^\circ\text{C}$ . (1983 - 2 Marks)
- When 2 gm of a gas  $A$  is introduced into an evacuated flask kept at  $25^\circ\text{C}$ , the pressure is found to be one atmosphere. If 3 gm of another gas  $B$  is then added to the same flask, the total pressure becomes 1.5 atm. Assuming ideal gas behaviour, calculate the ratio of the molecular weights  $M_A : M_B$ . (1983 - 2 Marks)
- Calculate the root mean square velocity of ozone kept in a closed vessel at  $20^\circ\text{C}$  and 82 cm mercury pressure. (1985 - 2 Marks)
- A spherical balloon of 21 cm diameter is to be filled up with hydrogen at N.T.P. from a cylinder containing the gas at 20 atmospheres at  $27^\circ\text{C}$ . If the cylinder can hold 2.82 litres of water, calculate the number of balloons that can be filled up. (1987 - 5 Marks)
- The average velocity at  $T_1\text{K}$ , and the most probable velocity at  $T_2\text{K}$  of  $\text{CO}_2$  gas is  $9.0 \times 10^4 \text{ cm sec}^{-1}$ . Calculate the value of  $T_1$  and  $T_2$ . (1990 - 4 Marks)
- Calculate the volume occupied by 5.0 g of acetylene gas at  $50^\circ\text{C}$  and 740 mm pressure. (1991 - 2 Marks)
- At  $27^\circ\text{C}$ , hydrogen is leaked through a tiny hole into a vessel for 20 minutes. Another unknown gas at the same temperature and pressure as that of  $\text{H}_2$  is leaked through the same hole for 20 minutes. After the effusion of the gases the mixture exerts a pressure of 6 atmosphere. The hydrogen content of the mixture is 0.7 mole. If the volume of the container is 3 litres, what is the molecular weight of the unknown gas? (1992 - 3 Marks)
- At room temperature the following reactions proceed nearly to completion : (1992 - 4 Marks)
 
$$2\text{NO} + \text{O}_2 \rightarrow 2\text{NO}_2 \rightarrow \text{N}_2\text{O}_4$$
 The dimer,  $\text{N}_2\text{O}_4$ , solidifies at 262 K. A 250 ml flask and a 100 ml. flask are separated by a stop-cock. At 300 K, the nitric oxide in the larger flask exerts a pressure of 1.053 atm. and the smaller one contains oxygen at 0.789 atm. The gases are mixed by opening the stopcock and after the end of the reaction the flasks are cooled at 220K. Neglecting the vapour pressure of the dimer, find out the pressure and composition of the gas remaining at 220 K. (Assume the gases to behave ideally).
- A gas bulb of 1 litre capacity contains  $2.0 \times 10^{21}$  molecules of nitrogen exerting a pressure of  $7.57 \times 10^3 \text{ Nm}^{-2}$ . Calculate the root mean square (r.m.s) speed and the temperature of the gas molecules. If the ratio of the most probable speed to the root mean square speed is 0.82, calculate the most probable speed for these molecules at this temperature. (1993 - 4 Marks)
- A 4 : 1 molar mixture of  $\text{He}$  and  $\text{CH}_4$  is contained in a vessel at 20 bar pressure. Due to a hole in the vessel, the gas mixture leaks out. What is the composition of the mixture effusing out initially? (1994 - 2 Marks)
- An LPG (liquefied petroleum gas) cylinder weighs 14.8 kg when empty. When full, it weighs 29.0 kg and shows a pressure of 2.5 atm. In the course of use at  $27^\circ\text{C}$ , the weight of the full cylinder reduces to 23.2 kg. Find out the volume of the gas in cubic meters used up at the normal usage conditions, find the final pressure inside the cylinder. Assume LPG to be  $n$ -butane with normal boiling point of  $0^\circ\text{C}$ . (1994 - 3 Marks)
- A mixture of ethane ( $\text{C}_2\text{H}_6$ ) and ethene ( $\text{C}_2\text{H}_4$ ) occupies 40 litres at 1.00 atm and at 400 K. The mixture reacts completely with 130 g of  $\text{O}_2$  to produce  $\text{CO}_2$  and  $\text{H}_2\text{O}$ . Assuming ideal gas behaviour, calculate the mole fractions of  $\text{C}_2\text{H}_4$  and  $\text{C}_2\text{H}_6$  in the mixture. (1995 - 4 Marks)
- The composition of the equilibrium mixture ( $\text{Cl}_2 \rightleftharpoons 2\text{Cl}$ ), which is attained at  $1200^\circ\text{C}$ , is determined by measuring the rate of effusion through a pin-hole. It is observed that at 1.80 mmHg pressure, the mixture effuses 1.16 times as fast as krypton effuses under the same conditions. Calculate the fraction of the chlorine molecules dissociated into atoms. (Relative atomic mass of  $\text{Kr} = 84$ .) (1995 - 4 Marks)
- A  $20.0 \text{ cm}^3$  mixture of  $\text{CO}$ ,  $\text{CH}_4$  and  $\text{He}$  gases is exploded by an electric discharge at room temperature with excess of oxygen. The volume contraction is found to be  $13.0 \text{ cm}^3$ . A further contraction of  $14.0 \text{ cm}^3$  occurs when the residual gas is treated with  $\text{KOH}$  solution. Find out the composition of the gaseous mixture in terms of volume percentage. (1995 - 4 Marks)
- An evacuated glass vessel weighs 50.0 g when empty, 148.0 g when filled with a liquid of density  $0.98 \text{ g mL}^{-1}$  and 50.5 g

- when filled with an ideal gas at 760 mmHg at 300K. Determine the molar mass of the gas. (1998 - 3 Marks)
22. The degree of dissociation is 0.4 at 400 K and 1.0 atm for the gaseous reaction  $\text{PCl}_5 \rightleftharpoons \text{PCl}_3 + \text{Cl}_2$ . Assuming ideal behaviour of all gases, calculate the density of equilibrium mixture at 400 K and 1.0 atmosphere. (Relative atomic mass of P = 31.0 and Cl = 35.5) (1998 - 3 Marks)
23. Using van der waal's equation, calculate the constant, 'a' when two moles of a gas confined in a four litre flask exerts a pressure of 11.0 atmospheres at a temperature of 300 K. The value of 'b' is 0.05 L mol<sup>-1</sup>. (1998 - 4 Marks)
24. For the reaction,  $\text{N}_2\text{O}_5(\text{g}) \rightarrow 2\text{NO}_2(\text{g}) + 0.5 \text{O}_2(\text{g})$ , calculate the mole fraction of  $\text{N}_2\text{O}_5(\text{g})$  decomposed at a constant volume and temperature, if the initial pressure is 600 mm Hg and the pressure at any time is 960 mm Hg. Assume ideal gas behaviour. (1998 - 3 Marks)
25. One mole of nitrogen gas at 0.8 atm takes 38 s to diffuse through a pinhole, whereas one mole of an unknown compound of xenon with flourine at 1.6 atm takes 57 s to diffuse through the same hole. Calculate the molecular formula of the compound. (1999 - 5 Marks)
26. The pressure exerted by 12 g of an ideal gas at temperature  $t^\circ\text{C}$  in a vessel of volume  $V$  litre is one atm. When the temperature is increased by 10 degrees at the same volume, the pressure increases by 10%. Calculate the temperature  $t$  and volume  $V$ . (Molecular weight of the gas = 120.) (1999 - 5 Marks)
27. Calculate the pressure exerted by one mole of  $\text{CO}_2$  gas at 273 K if the van der Waal's constant  $a = 3.592 \text{ dm}^6 \text{ atm mol}^{-2}$ . Assume that the volume occupied by  $\text{CO}_2$  molecules is negligible. (2000 - 2 Marks)
28. The compression factor (compressibility factor) for one mole of a van der Waals gas at  $0^\circ\text{C}$  and 100 atmospheric pressure is found to be 0.5. Assuming that the volume of a gas molecule is negligible, calculate the van der Waals constant  $a$ . (2001 - 5 Marks)
29. The density of the vapour of a substance at 1 atm pressure and 500 K is  $0.36 \text{ kg m}^{-3}$ . The vapour effuses through a small hole at a rate of 1.33 times faster than oxygen under the same condition. (2002 - 5 Marks)
- (a) Determine  
(i) molecular weight,  
(ii) molar volume,  
(iii) compression factor ( $Z$ ) of the vapour and  
(iv) which forces among the gas molecules are dominating, the attractive or the repulsive?
- (b) If the vapour behaves ideally at 1000 K, determine the average translational kinetic energy of a molecule.
30. The average velocity of gas molecules is 400 m/sec. Calculate its rms velocity at the same temperature. (2003 - 2 Marks)
31. A graph is plotted between  $PV_m$  along Y-axis and  $P$  along X-axis, where  $V_m$  is the molar volume of a real gas. Find the intercept along Y-axis. (2004 - 2 Marks)

## F Match The Following

Each question contains statements given in two columns, which have to be matched. The statements in Column-I are labelled A, B, C and D, while the statements in Column-II are labelled p, q, r, s and t. Any given statement in Column-I can have correct matching with ONE OR MORE statement(s) in Column-II. The appropriate bubbles corresponding to the answers to these questions have to be darkened as illustrated in the following example :

If the correct matches are A-p, s and t; B-q and r; C-p and q; and D-s then the correct darkening of bubbles will look like the given.

	p	q	r	s	t
A	<input checked="" type="checkbox"/>	<input checked="" type="checkbox"/>	<input type="checkbox"/>	<input checked="" type="checkbox"/>	<input checked="" type="checkbox"/>
B	<input type="checkbox"/>	<input checked="" type="checkbox"/>	<input checked="" type="checkbox"/>	<input type="checkbox"/>	<input type="checkbox"/>
C	<input checked="" type="checkbox"/>	<input checked="" type="checkbox"/>	<input type="checkbox"/>	<input type="checkbox"/>	<input type="checkbox"/>
D	<input type="checkbox"/>	<input type="checkbox"/>	<input type="checkbox"/>	<input checked="" type="checkbox"/>	<input type="checkbox"/>

1. Match gases under specified conditions listed in **Column I** with their properties/laws in **Column II**. Indicate your answer by darkening the appropriate bubbles of the  $4 \times 4$  matrix given in the ORS. (2007)

### Column I

- (A) Hydrogen gas ( $P = 200 \text{ atm}$ ,  $T = 273 \text{ K}$ )  
 (B) Hydrogen gas ( $P \sim 0$ ,  $T = 273 \text{ K}$ )  
 (C)  $\text{CO}_2$  ( $P = 1 \text{ atm}$ ,  $T = 273 \text{ K}$ )  
 (D) Real gas with very large molar volume

### Column II

- (p) Compressibility factor  $\neq 1$   
 (q) Attractive forces are dominant  
 (r)  $PV = nRT$   
 (s)  $P(V - nb) = nRT$

## G Comprehension Based Questions

$X$  and  $Y$  are two volatile liquids with molar weights of  $10 \text{ g mol}^{-1}$  and  $40 \text{ g mol}^{-1}$  respectively. Two cotton plugs, one soaked in  $X$  and the other soaked in  $Y$ , are simultaneously placed at the ends of a tube of length  $L = 24 \text{ cm}$ , as shown in the figure. The tube is filled with an inert gas at 1 atmosphere pressure and a temperature of 300 K. Vapours of  $X$  and  $Y$  react to form a product which is first

observed at a distance  $d \text{ cm}$  from the plug soaked in  $X$ . Take  $X$  and  $Y$  to have equal molecular diameters and assume ideal behaviour for the inert gas and the two vapours.

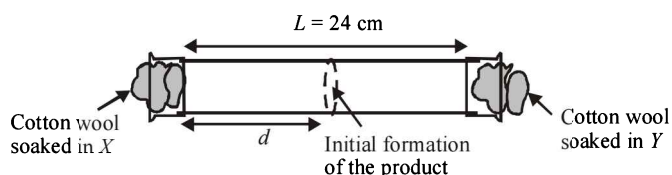

## States of Matter

- The value of  $d$  in cm (shown in the figure), as estimated from Graham's law, is (JEE Adv. 2014)
  - 8
  - 12
  - 16
  - 20
- The experimental value of  $d$  is found to be smaller than the estimate obtained using Graham's law. This is due to (JEE Adv. 2014)
  - Larger mean free path for  $X$  as compared to that of  $Y$
  - Larger mean free path for  $Y$  as compared to that of  $X$
  - Increased collision frequency of  $Y$  with the inert gas as compared to that of  $X$  with the inert gas
  - Increased collision frequency of  $X$  with the inert gas as compared to that of  $Y$  with the inert gas

## H Assertion & Reason Type Questions

- Read the following statement and explanation and answer as per the options given below :  
**Assertion :** The value of van der Waals' constant 'a' is larger for ammonia than for nitrogen.  
**Reason :** Hydrogen bonding is present in ammonia. (1998 - 2 Marks)
  - If both *assertion* and *reason* are correct, and *reason* is the correct explanation of the *assertion*.
  - If both *assertion* and *reason* are correct, but *reason* is not the correct explanation of the *assertion*.
  - If *assertion* is correct but *reason* is incorrect.
  - If *assertion* is incorrect but *reason* is correct.

## I Integer Value Correct Type

- At 400 K, the root mean square (rms) speed of a gas X (molecular weight = 40) is equal to the most probable speed of gas Y at 60 K. The molecular weight of the gas Y is (2009)
- To an evacuated vessel with movable piston under external pressure of 1 atm, 0.1 mol of He and 1.0 mol of an unknown compound (vapour pressure 0.68 atm. at 0°C) are introduced. Considering the ideal gas behaviour, the total volume (in litre) of the gases at 0°C is close to (2011)
- The diffusion coefficient of an ideal gas is proportional to its mean free path and mean speed. The absolute temperature of an ideal gas is increased 4 times and its pressure is increased 2 times. As a result, the diffusion coefficient of this gas increases  $x$  times. The value of  $x$  is (JEE Adv. 2016)

## Section-B JEE Main / AIEEE

- For an ideal gas, number of moles per litre in terms of its pressure  $P$ , gas constant  $R$  and temperature  $T$  is [2002]
  - $PT/R$
  - $PRT$
  - $P/RT$
  - $RT/P$
- Value of gas constant  $R$  is [2002]
  - 0.082 litre atm
  - 0.987 cal mol<sup>-1</sup> K<sup>-1</sup>
  - 8.3 J mol<sup>-1</sup> K<sup>-1</sup>
  - 83 erg mol<sup>-1</sup> K<sup>-1</sup>
- Kinetic theory of gases proves [2002]
  - only Boyle's law
  - only Charles' law
  - only Avogadro's law
  - All of these.
- According to the kinetic theory of gases, in an ideal gas, between two successive collisions a gas molecule travels [2003]
  - in a wavy path
  - in a straight line path
  - with an accelerated velocity
  - in a circular path
- As the temperature is raised from 20°C to 40°C, the average kinetic energy of neon atoms changes by a factor of which of the following? [2004]
  - $\frac{313}{293}$
  - $\sqrt{(313/293)}$
  - $\frac{1}{2}$
  - 2
- In van der Waals equation of state of the gas law, the constant 'b' is a measure of [2004]
  - volume occupied by the molecules
  - intermolecular attraction
  - intermolecular repulsions
  - intermolecular collisions per unit volume
- Which one of the following statements is NOT true about the effect of an increase in temperature on the distribution of molecular speeds in a gas? [2005]
  - The area under the distribution curve remains the same as under the lower temperature
  - The distribution becomes broader
  - The fraction of the molecules with the most probable speed increases
  - The most probable speed increases
- If 10<sup>-4</sup> dm<sup>3</sup> of water is introduced into a 1.0 dm<sup>3</sup> flask at 300 K, how many moles of water are in the vapour phase when equilibrium is established? [2010]

(Given : Vapour pressure of  $H_2O$  at 300 K is 3170 Pa;  
 $R = 8.314 \text{ J K}^{-1} \text{ mol}^{-1}$ )

- (a)  $5.56 \times 10^{-3} \text{ mol}$  (b)  $1.53 \times 10^{-2} \text{ mol}$   
 (c)  $4.46 \times 10^{-2} \text{ mol}$  (d)  $1.27 \times 10^{-3} \text{ mol}$
9. 'a' and 'b' are van der Waals' constants for gases. Chlorine is more easily liquefied than ethane because [2011]

- (a) a and b for  $Cl_2 > a$  and b for  $C_2H_6$   
 (b) a and b for  $Cl_2 < a$  and b for  $C_2H_6$   
 (c) a for  $Cl_2 < a$  for  $C_2H_6$  but b for  $Cl_2 > b$  for  $C_2H_6$   
 (d) a for  $Cl_2 > a$  for  $C_2H_6$  but b for  $Cl_2 < b$  for  $C_2H_6$

10. The compressibility factor for a real gas at high pressure is :

(a)  $1 + \frac{RT}{pb}$  (b) 1 [2012]

(c)  $1 + \frac{pb}{RT}$  (d)  $1 - \frac{pb}{RT}$

11. For gaseous state, if most probable speed is denoted by  $C^*$ , average speed by  $\bar{C}$  and mean square speed by  $C$ , then for a large number of molecules the ratios of these speeds are :

[JEE M 2013]

- (a)  $C^* : \bar{C} : C = 1.225 : 1.128 : 1$   
 (b)  $C^* : \bar{C} : C = 1.128 : 1.225 : 1$   
 (c)  $C^* : \bar{C} : C = 1 : 1.128 : 1.225$   
 (d)  $C^* : \bar{C} : C = 1 : 1.225 : 1.128$

12. If  $Z$  is a compressibility factor, van der Waals equation at low pressure can be written as: [JEE M 2014]

(a)  $Z = 1 + \frac{RT}{Pb}$  (b)  $Z = 1 - \frac{a}{VRT}$

(c)  $Z = 1 - \frac{Pb}{RT}$  (d)  $Z = 1 + \frac{Pb}{RT}$

13. The ratio of masses of oxygen and nitrogen in a particular gaseous mixture is 1 : 4. The ratio of number of their molecule is: [JEE M 2014]

- (a) 1 : 4 (b) 7 : 32  
 (c) 1 : 8 (d) 3 : 16

14. The intermolecular interaction that is dependent on the inverse cube of distance between the molecules is :

[JEE M 2015]

- (a) London force (b) hydrogen bond  
 (c) ion - ion interaction (d) ion - dipole interaction

15. Two closed bulbs of equal volume ( $V$ ) containing an ideal gas initially at pressure  $p_i$  and temperature  $T_1$  are connected through a narrow tube of negligible volume as shown in the figure below. The temperature of one of the bulbs is then raised to  $T_2$ . The final pressure  $p_f$  is : [JEE M 2016]

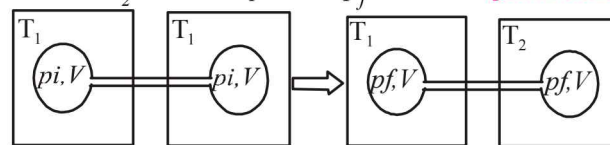

(a)  $2p_i \left( \frac{T_2}{T_1 + T_2} \right)$  (b)  $2p_i \left( \frac{T_1 T_2}{T_1 + T_2} \right)$

(c)  $p_i \left( \frac{T_1 T_2}{T_1 + T_2} \right)$  (d)  $2p_i \left( \frac{T_1}{T_1 + T_2} \right)$



## CHAPTER

## 6

## Thermodynamics

## Section-A

## JEE Advanced/ IIT-JEE

## A Fill in the Blanks

1. A system is said to be ..... if it can neither exchange matter nor energy with the surroundings. (1993 - 1 Mark)
2. The heat content of the products is more than that of the reactants in an ..... reaction. (1993 - 1 Mark)
3. Enthalpy is an ..... property. (1997 - 1 Mark)

## B True / False

1. First law of thermodynamics is not adequate in predicting the direction of a process. (1982 - 1 Mark)
2. Heat capacity of a diatomic gas is higher than that of a monoatomic gas. (1985 - ½ Mark)

## C MCQs with One Correct Answer

1. The difference between heats of reaction at constant pressure and constant volume for the reaction :  
 $2\text{C}_6\text{H}_6(l) + 15\text{O}_2(g) \rightarrow 12\text{CO}_2(g) + 6\text{H}_2\text{O}(l)$  at  $25^\circ\text{C}$  in kJ is (1991 - 1 Mark)
 

(a) -7.43	(b) +3.72
(c) -3.72	(d) +7.43
2. For which change  $\Delta H \neq \Delta E$ : (1995S)
 

(a) $\text{H}_2(g) + \text{I}_2(g) \rightarrow 2\text{HI}(g)$	(b) $\text{HCl} + \text{NaOH} \rightarrow \text{NaCl}$
(c) $\text{C}(s) + \text{O}_2(g) \rightarrow \text{CO}_2(g)$	(d) $\text{N}_2(g) + 3\text{H}_2(g) \rightarrow 2\text{NH}_3(g)$
3. The  $\Delta H_f^\circ$  for  $\text{CO}_2(g)$ ,  $\text{CO}(g)$  and  $\text{H}_2\text{O}(g)$  are  $-393.5$ ,  $-110.5$  and  $-241.8$  kJ mol<sup>-1</sup> respectively. The standard enthalpy change (in kJ) for the reaction  $\text{CO}_2(g) + \text{H}_2(g) \rightarrow \text{CO}(g) + \text{H}_2\text{O}(g)$  is (2000S)
 

(a) 524.1	(b) 41.2
(c) -262.5	(d) -41.2
4. In thermodynamics, a process is called reversible when (2001S)
 

(a) surroundings and system change into each other.
(b) there is no boundary between system and surroundings.
(c) the surroundings are always in equilibrium with the system.
(d) the system changes into the surroundings spontaneously.

5. Which one of the following statements is false? (2001S)
 

(a) Work is a state function.
(b) Temperature is a state function.
(c) Change in the state is completely defined when the initial and final states are specified.
(d) Work appears at the boundary of the system.
6. One mole of a non-ideal gas undergoes a change of state (2.0 atm, 3.0L, 95(K)  $\rightarrow$  (4.0 atm, 5.0 L, 245K) with a change in internal energy,  $\Delta U = 30.0$  L atm. The change in enthalpy ( $\Delta H$ ) of the process in L atm is (2002S)
 

(a) 40.0
(b) 42.3
(c) 44.0
(d) not defined, because pressure is not constant
7. Which of the reaction defines  $\Delta H_f^\circ$ ? (2003S)
 

(a) $\text{C}(\text{diamond}) + \text{O}_2(g) \rightarrow \text{CO}_2(g)$
(b) $\frac{1}{2}\text{H}_2(g) + \frac{1}{2}\text{F}_2(g) \rightarrow \text{HF}(g)$
(c) $\text{N}_2(g) + 3\text{H}_2(g) \rightarrow 2\text{NH}_3(g)$
(d) $\text{CO}(g) + \frac{1}{2}\text{O}_2(g) \rightarrow \text{CO}_2(g)$
8. Two moles of an ideal gas is expanded isothermally and reversibly from 1 litre to 10 litre at 300 K. The enthalpy change (in kJ) for the process is (2004S)
 

(a) 11.4 kJ	(b) -11.4 kJ
(c) 0 kJ	(d) 4.8 kJ
9. The enthalpy of vapourization of liquid is 30 kJ mol<sup>-1</sup> and entropy of vapourization is 75 J mol<sup>-1</sup> K. The boiling point of the liquid at 1 atm is (2004S)
 

(a) 250 K	(b) 400 K
(c) 450 K	(d) 600 K
10. The direct conversion of A to B is difficult, hence it is carried out by the following shown path :

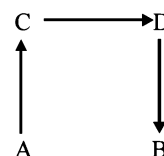

Given

 $\Delta S_{(A \rightarrow C)} = 50 \text{ e.u.}$ ,  $\Delta S_{(C \rightarrow D)} = 30 \text{ e.u.}$ ,  $\Delta S_{(B \rightarrow D)} = 20 \text{ e.u.}$ ,  
 where e.u. is the entropy unit, then  $\Delta S_{(A \rightarrow B)}$  is

(2006 - 3M, -1)

- |              |               |
|--------------|---------------|
| (a) +60 e.u. | (b) +100 e.u. |
| (c) -60 e.u. | (d) -100 e.u. |

11. The value of  $\log_{10} K$  for a reaction  $A \rightleftharpoons B$  is  
(Given :  $\Delta_r H_{298K}^\circ = -54.07 \text{ kJ mol}^{-1}$ ,  $\Delta_r S_{298K}^\circ = 10 \text{ JK}^{-1} \text{ mol}^{-1}$  and  $R = 8.314 \text{ JK}^{-1} \text{ mol}^{-1}$ ;  $2.303 \times 8.314 \times 298 = 5705$ ) (2007)
- (a) 5 (b) 10  
(c) 95 (d) 100
12. For the process  $\text{H}_2\text{O}(l)$  (1 bar, 373 K)  $\rightarrow$   $\text{H}_2\text{O}(g)$  (1 bar, 373 K), the correct set of thermodynamic parameters is (2007)
- (a)  $\Delta G = 0$ ,  $\Delta S = +ve$  (b)  $\Delta G = 0$ ,  $\Delta S = -ve$   
(c)  $\Delta G = +ve$ ,  $\Delta S = 0$  (d)  $\Delta G = -ve$ ,  $\Delta S = +ve$
13. The species which by definition has **ZERO** standard molar enthalpy of formation at 298 K is (2010)
- (a)  $\text{Br}_2(g)$  (b)  $\text{Cl}_2(g)$   
(c)  $\text{H}_2\text{O}(g)$  (d)  $\text{CH}_4(g)$
14. The standard enthalpies of formation of  $\text{CO}_2(g)$ ,  $\text{H}_2\text{O}(l)$  and glucose(s) at  $25^\circ\text{C}$  are  $-400 \text{ kJ/mol}$ ,  $-300 \text{ kJ/mol}$  and  $-1300 \text{ kJ/mol}$ , respectively. The standard enthalpy of combustion per gram of glucose at  $25^\circ\text{C}$  is (JEE Advanced 2013-I)
- (a)  $+2900 \text{ kJ}$  (b)  $-2900 \text{ kJ}$   
(c)  $-16.11 \text{ kJ}$  (d)  $+16.11 \text{ kJ}$
15. For the process (JEE Adv. 2014)  
 $\text{H}_2\text{O}(l) \rightarrow \text{H}_2\text{O}(g)$   
at  $T = 100^\circ\text{C}$  and 1 atmosphere pressure, the correct choice is
- (a)  $\Delta S_{\text{system}} > 0$  and  $\Delta S_{\text{surroundings}} > 0$   
(b)  $\Delta S_{\text{system}} > 0$  and  $\Delta S_{\text{surroundings}} < 0$   
(c)  $\Delta S_{\text{system}} < 0$  and  $\Delta S_{\text{surroundings}} > 0$   
(d)  $\Delta S_{\text{system}} < 0$  and  $\Delta S_{\text{surroundings}} < 0$
16. One mole of an ideal gas at  $300 \text{ K}$  in thermal contact with surroundings expands isothermally from  $1.0 \text{ L}$  to  $2.0 \text{ L}$  against a constant pressure of  $3.0 \text{ atm}$ . In this process, the change in entropy of surroundings ( $\Delta S_{\text{surr}}$ ) in  $\text{JK}^{-1}$  is ( $1 \text{ L atm} = 101.3 \text{ J}$ ) (JEE Adv. 2016)
- (a) 5.763 (b) 1.013  
(c)  $-1.013$  (d)  $-5.763$

## D MCQs with One or More Than One Correct

1. Identify the intensive quantities from the following: (1993 - 1 Mark)
- (a) Enthalpy (b) Temperature  
(c) Volume (d) Refractive Index
2. The following is (are) endothermic reaction(s): (1999 - 3 Marks)
- (a) Combustion of methane  
(b) Decomposition of water  
(c) Dehydrogenation of ethane to ethylene  
(d) Conversion of graphite to diamond
3. Among the following the state function(s) is (are) (2009)
- (a) Internal energy  
(b) Irreversible expansion work  
(c) Reversible expansion work  
(d) Molar enthalpy
4. Among the following, the intensive property is (properties are) (2010)
- (a) molar conductivity (b) electromotive force  
(c) resistance (d) heat capacity
5. For an ideal gas, consider only P-V work in going from an initial state X to the final state Z. The final state Z can be reached by either of the two paths shown in the figure. Which of the following choice(s) is (are) correct?

[Take  $\Delta S$  as change in entropy and was work done]. (2012)

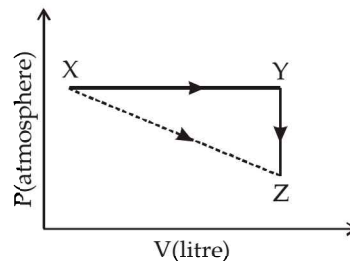

- (a)  $\Delta S_{x \rightarrow z} = \Delta S_{x \rightarrow y} + \Delta S_{y \rightarrow z}$   
(b)  $w_{x \rightarrow z} = w_{x \rightarrow y} + w_{y \rightarrow z}$   
(c)  $w_{x \rightarrow y \rightarrow z} = w_{x \rightarrow y}$   
(d)  $\Delta S_{x \rightarrow y \rightarrow z} = \Delta S_{x \rightarrow y}$
6. The reversible expansion of an ideal gas under adiabatic and isothermal conditions is shown in the figure. Which of the following statement(s) is (are) correct?

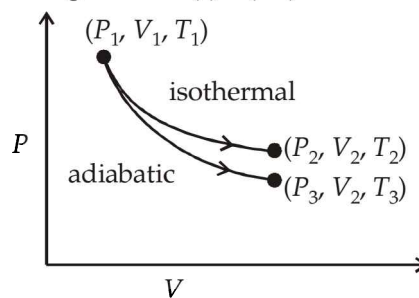

- (a)  $T_1 = T_2$  (2012 - II)  
(b)  $T_3 > T_1$   
(c)  $w_{\text{isothermal}} > w_{\text{adiabatic}}$   
(d)  $\Delta U_{\text{isothermal}} > \Delta U_{\text{adiabatic}}$
7. An ideal gas in a thermally insulated vessel at internal pressure =  $P_1$ , volume =  $V_1$  and absolute temperature =  $T_1$  expands irreversibly against zero external pressure, as shown in the diagram. The final internal pressure, volume and absolute temperature of the gas are  $P_2$ ,  $V_2$  and  $T_2$ , respectively. For this expansion, (JEE Adv. 2014)

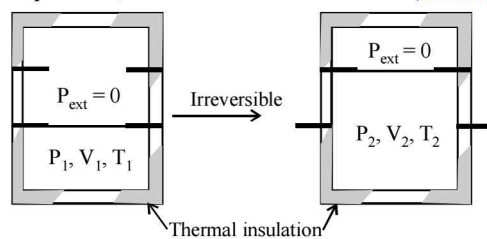

- (a)  $q = 0$  (b)  $T_2 = T_1$   
(c)  $P_2 V_2 = P_1 V_1$  (d)  $P_2 V_2^\gamma = P_1 V_1^\gamma$

## E Subjective Problems

1. The enthalpy for the following reaction ( $\Delta H^\circ$ ) at  $25^\circ\text{C}$  are given below: (1981 - 2 Marks)
- (i)  $\frac{1}{2} \text{H}_2(g) + \frac{1}{2} \text{O}_2(g) \rightarrow \text{OH}(g)$  10.06 kcal  
(ii)  $\text{H}_2(g) \rightarrow 2\text{H}(g)$  104.18 kcal  
(iii)  $\text{O}_2(g) \rightarrow 2\text{O}(g)$  118.32 kcal
- Calculate the O-H bond energy in the hydroxyl radical.

2. The molar heats of combustion of  $C_2H_2(g)$ , C(graphite) and  $H_2(g)$  are 310.62 kcal, 94.05 kcal and 68.32 kcal, respectively. Calculate the standard heat of formation of  $C_2H_2(g)$ .  
(1983 - 2 Marks)
3. The heat energy,  $q$ , absorbed by a gas  $\Delta H$ , is true at what condition(s).  
(1984 - 1 Mark)
4. Given the following standard heats of reactions :  
(i) heat of formation of water = -68.3 kcal;  
(ii) heat of combustion of acetylene = -310.6 kcal;  
(iii) heat of combustion of ethylene = -337.2 kcal;  
Calculate the heat of reaction for the hydrogenation of acetylene at constant volume (25°C). (1984 - 4 Marks)
5. The bond dissociation energies of gaseous  $H_2$ ,  $Cl_2$  and  $HCl$  are 104, 58 and 103 kcal/mole respectively. Calculate the enthalpy of formation of  $HCl$  gas. (1985 - 2 Marks)
6. The standard molar heats of formation of ethane, carbon dioxide and liquid water are -21.1, -94.1 and -68.3 kcal respectively. Calculate the standard molar heat of combustion of ethane. (1986 - 2 Marks)
7. An intimate mixture of ferric oxide,  $Fe_2O_3$ , and aluminium, Al, is used in solid fuel rockets. Calculate the fuel value per gram and fuel value per cc of the mixture. Heats of formation and densities are as follows : (1988 - 2 Marks)  
 $H_f(Al_2O_3) = 399$  kcal/mole;  
 $H_f(Fe_2O_3) = 199$  kcal/mole;  
Density of  $Fe_2O_3 = 5.2$  g/cc;  
Density of Al = 2.7 g/cc.
8. An athlete is given 100 gm of glucose ( $C_6H_{12}O_6$ ) of energy equivalent to 1560 kJ. He utilizes 50 percent of this gained energy in the event. In order to avoid storage of energy in the body, calculate the weight of water he would need to perspire. The enthalpy of evaporation of water is 44 kJ/mole. (1989 - 2 Marks)
9. The standard enthalpy of combustion at 25°C of hydrogen, cyclohexene ( $C_6H_{10}$ ) and cyclohexane ( $C_6H_{12}$ ) are -241, -3800 and -3920 kJ/mole respectively. Calculate the heat of hydrogenation of cyclohexene. (1989 - 2 Marks)
10. Using the data (all values are in kcal mol<sup>-1</sup> at 25°C) given below, calculate the bond energy of C-C and C-H bonds. (1990 - 5 Marks)
- |  |   |        |
|--|---|--------|
| $\Delta H^\circ_{\text{combustion}}(\text{ethane})$  | = | -372.0 |
| $\Delta H^\circ_{\text{combustion}}(\text{propane})$ | = | -530.0 |
| $\Delta H^\circ_{C(s) \rightarrow C(g)}$             | = | 172.0  |
| Bond energy of H-H                                   | = | 104.0  |
| $\Delta H^\circ_f$ of $H_2O(l)$                      | = | -68.0  |
| $\Delta H^\circ_f$ of $CO_2(g)$                      | = | -94.0  |
11. A gas mixture of 3.67 litres of ethylene and methane on complete combustion at 25°C produces 6.11 litres of  $CO_2$ . Find out the amount of heat evolved on burning one litre of the gas mixture. The heats of combustion of ethylene and methane are -1423 and -891 kJ mol<sup>-1</sup> at 25°C.  
(1991 - 5 Marks)
12. Determine the enthalpy change of the reaction.  
 $C_3H_8(g) + H_2(g) \rightarrow C_2H_6(g) + CH_4(g)$ , at 25°, using the given heat of combustion values under standard conditions:  
Compound     $H_2(g)$      $CH_4(g)$      $C_2H_6(g)$     C(graphite)  
 $\Delta H^\circ$  (kJ/mol)   -285.8    -890.0    -1560.0    -393.5  
The standard heat of formation of  $C_3H_8(g)$  is -103.8 kJ/mol.  
(1992 - 3 Marks)
13. In order to get maximum calorific output, a burner should have an optimum fuel to oxygen ratio which corresponds to 3 times as much oxygen as is required theoretically for complete combustion of the fuel. A burner which has been adjusted for methane as fuel (with x litre/hour of  $CH_4$  and 6x litre/hour of  $O_2$ ) is to be readjusted for butane,  $C_4H_{10}$ . In order to get the same calorific output, what should be the rate of supply of butane and oxygen? Assume that losses due to incomplete combustion, etc, are the same for both the fuels and the gases behave ideally. (1993 - 3 Marks)  
Heats of combustion :  
 $CH_4 = 809$  kJ/mol;  $C_4H_{10} = 2878$  kJ/mol
14. The polymerisation of ethylene to linear polyethylene is represented by the reaction (1994 - 2 Marks)  
 $nCH_2=CH_2 \longrightarrow \text{---} [CH_2-CH_2]_n \text{---}$   
where n has a large integral value. Given that the average enthalpies of bond dissociation for C=C and C-C at 298 K are + 590 and + 331 kJ mol<sup>-1</sup>, respectively, calculate the enthalpy of polymerisation per mole of ethylene at 298 K.
15. The standard molar enthalpies of formation of cyclohexane(l) and benzene(l) at 25°C are -156 and + 49 kJ mol<sup>-1</sup> respectively. The standard enthalpy of hydrogenation of cyclohexene(l) at 25°C is -119 kJ mol<sup>-1</sup>. Use these data to estimate the magnitude of the resonance energy of benzene. (1996 - 2 Marks)
16. Compute the heat of formation of liquid methyl alcohol in kilojoules per mole, using the following data. Heat of vaporization of liquid methyl alcohol = 38 kJ/mol. Heat of formation of gaseous atoms from the elements in their standard states; H, 218 kJ/mol; C, 715 kJ/mol; O, 249 kJ/mol. Average bond energies :  
C-H = 415 kJ/mol, C-O = 365 kJ/mol, O-H = 463 kJ/mol  
(1997 - 5 Marks)
17. Anhydrous  $AlCl_3$  is covalent. From the data given below, predict whether it would remain covalent or become ionic in aqueous solution. (Ionisation energy for Al = 5137 kJ mol<sup>-1</sup>;  $\Delta H_{\text{hydration}}$  for  $Al^{3+} = -4665$  kJ mol<sup>-1</sup>;  $\Delta H_{\text{hydration}}$  for  $Cl^- = -381$  kJ mol<sup>-1</sup>.) (1997 - 2 Marks)
18. From the following data, calculate the enthalpy change for the combustion of cyclopropane at 298 K. The enthalpy of formation of  $CO_2(g)$ ,  $H_2O(l)$  and propene(g) are - 393.5, - 285.8 and 20.42 kJ mol<sup>-1</sup> respectively. The enthalpy of isomerisation of cyclopropane to propene is - 33.0 kJ mol<sup>-1</sup>.  
(1998 - 5 Marks)

19. Estimate the average S–F bond energy in SF<sub>6</sub>. The values of standard enthalpy of formation of SF<sub>6</sub>(g), S(g) and F(g) are : – 1100, 275 and 80 kJ mol<sup>-1</sup> respectively. (1999 - 3 Marks)
20. A sample of argon gas at 1 atm pressure and 27°C expands reversibly and adiabatically from 1.25 dm<sup>3</sup> to 2.50 dm<sup>3</sup>. Calculate the enthalpy change in this process. C<sub>v,m</sub> for argon is 12.48 JK<sup>-1</sup> mol<sup>-1</sup>. (2000 - 4 Marks)
21. Show that the reaction  $\text{CO}(g) + \frac{1}{2}\text{O}_2(g) \longrightarrow \text{CO}_2(g)$  at 300 K, is spontaneous and exothermic, when the standard entropy change is –0.094 kJ mol<sup>-1</sup> K<sup>-1</sup>. The standard Gibbs free energies of formation for CO<sub>2</sub> and CO are –394.4 and –137.2 kJ mol<sup>-1</sup>, respectively. (2000 - 3 Marks)
22. Diborane is a potential rocket fuel which undergoes combustion according to the reaction. (2000 - 2 Marks)  
 $\text{B}_2\text{H}_6(g) + 3\text{O}_2(g) \rightarrow \text{B}_2\text{O}_3(s) + 3\text{H}_2\text{O}(g)$   
 From the following data, calculate the enthalpy change for the combustion of diborane.
- $$2\text{B}(s) + \frac{3}{2}\text{O}_2(g) \longrightarrow \text{B}_2\text{O}_3(s) \quad \Delta H = -1273 \text{ kJ mol}^{-1}$$
- $$\text{H}_2(g) + \frac{1}{2}\text{O}_2(g) \longrightarrow \text{H}_2\text{O}(\ell) \quad \Delta H = -286 \text{ kJ mol}^{-1}$$
- $$\text{H}_2\text{O}(\ell) \longrightarrow \text{H}_2\text{O}(g) \quad \Delta H = 44 \text{ kJ mol}^{-1}$$
- $$2\text{B}(s) + 3\text{H}_2(g) \longrightarrow \text{B}_2\text{H}_6(g) \quad \Delta H = 36 \text{ kJ mol}^{-1}$$
23. When 1-pentyne (A) is treated with 4 N alcoholic KOH at 175°C, it is converted slowly into an equilibrium mixture of 1.3% 1-pentyne (A), 95.2% 2-pentyne (B) and 3.5% of 1, 2-pentadiene (C). The equilibrium was maintained at 175°C. Calculate ΔG° for the following equilibria :
- $$\text{B} \rightleftharpoons \text{A} \quad \Delta G_1^\circ = ? \quad \text{B} \rightleftharpoons \text{C} \quad \Delta G_2^\circ = ?$$
- From the calculated value of ΔG<sub>1</sub><sup>°</sup> and ΔG<sub>2</sub><sup>°</sup> indicate the order of stability of (A), (B) and (C). Write a reasonable reaction mechanism showing all intermediates leading to (A), (B) and (C). (2001 - 10 Marks)
24. Two moles of a perfect gas undergo the following processes: (2002 - 5 Marks)
- a reversible isobaric expansion from (1.0 atm, 20.0 L) to (1.0 atm, 40.0 L);
  - a reversible isochoric change of state from (1.0 atm, 40.0 L) to (0.5 atm, 40.0 L);
  - a reversible isothermal compression from (0.5 atm, 40.0 L) to (1.0 atm, 20.0 L).
- Sketch with labels each of the processes on the same P-V diagram.
  - Calculate the total work (w) and the total heat change (q) involved in the above processes.
  - What will be the values of ΔU, ΔH and ΔS for the overall process?
25. C<sub>v</sub> value of He is always 3R/2 but C<sub>v</sub> value of H<sub>2</sub> is 3R/2 at low temperature and 5R/2 at moderate temperature and more than 5R/2 at higher temperature explain in two to three lines. (2003 - 2 Marks)
26. An insulated container contains 1 mol of a liquid, molar volume 100 ml, at 1 bar. When liquid is steeply pressed to 100 bar, volume decreases to 99 ml. Find. ΔH and ΔU for the process. (2004 - 2 Marks)
27. In the following equilibrium  $\text{N}_2\text{O}_4(g) \rightleftharpoons 2\text{NO}_2(g)$  (2004 - 2 Marks)
- When 5 moles of each is taken and the temperature is kept at 298 K, the total pressure was found to be 20 bar.
- Given : ΔG<sub>f</sub><sup>°</sup>(N<sub>2</sub>O<sub>4</sub>) = 100 kJ; ΔG<sub>f</sub><sup>°</sup>(NO<sub>2</sub>) = 50 kJ
- Find ΔG of the reaction at 298 K.
  - Find the direction of the reaction
28. For the reaction,  $2\text{CO} + \text{O}_2 \longrightarrow 2\text{CO}_2$ ; ΔH = –560 kJ. Two moles of CO and one mole of O<sub>2</sub> are taken in a container of volume 1 L. They completely form two moles of CO<sub>2</sub>, the gases deviate appreciably from ideal behaviour. If the pressure in the vessel changes from 70 to 40 atm, find the magnitude (absolute value) of ΔU at 500 K. (1 L atm = 0.1 kJ) (2006 - 6M)

## F Match The Following

**DIRECTION (Q. 1 & 2):** Each question contains statements given in two columns, which have to be matched. The statements in Column-I are labelled A, B, C and D, while the statements in Column-II are labelled p, q, r, s and t. Any given statement in Column-I can have correct matching with ONE OR MORE statement(s) in Column-II. The appropriate bubbles corresponding to the answers to these questions have to be darkened as illustrated in the following example :

If the correct matches are A-p, s and t; B-q and r; C-p and q; and D-s then the correct darkening of bubbles will look like the given.

	p	q	r	s	t
A	<input checked="" type="checkbox"/>	<input type="checkbox"/>	<input type="checkbox"/>	<input checked="" type="checkbox"/>	<input checked="" type="checkbox"/>
B	<input type="checkbox"/>	<input checked="" type="checkbox"/>	<input checked="" type="checkbox"/>	<input type="checkbox"/>	<input type="checkbox"/>
C	<input checked="" type="checkbox"/>	<input checked="" type="checkbox"/>	<input type="checkbox"/>	<input type="checkbox"/>	<input type="checkbox"/>
D	<input type="checkbox"/>	<input type="checkbox"/>	<input type="checkbox"/>	<input checked="" type="checkbox"/>	<input type="checkbox"/>

1. Match the transformations in column I with appropriate options in column II (2011)

### Column-I

- CO<sub>2</sub>(s) → CO<sub>2</sub>(g)
- CaCO<sub>3</sub>(s) → CaO(s) + CO<sub>2</sub>(g)
- 2H<sup>•</sup> → H<sub>2</sub>(g)
- P<sub>(white, solid)</sub> → P<sub>(red, solid)</sub>

### Column-II

- phase transition
- allotropic change
- ΔH is positive
- ΔS is positive
- ΔS is negative

2. Match the thermodynamic processes given under Column-I with the expressions given under Column-II. (JEE Adv. 2015)

## Column-I

- (A) Freezing of water at 273 K and 1 atm  
 (B) Expansion of 1 mol of an ideal gas into a vacuum under isolated conditions  
 (C) Mixing of equal volumes of two ideal gases at constant temperature and pressure in an isolated container  
 (D) Reversible heating of  $\text{H}_2(\text{g})$  at 1 atm from 300 K to 600 K, followed by reversible cooling to 300 K at 1 atm

## Column-II

- (p)  $q=0$   
 (q)  $w=0$   
 (r)  $\Delta S_{\text{sys}} < 0$   
 (s)  $\Delta U=0$   
 (t)  $\Delta G=0$

### G Comprehension Based Questions

A fixed mass 'm' of a gas is subjected to transformation of states from K to L to M to N and back to K as shown in the figure

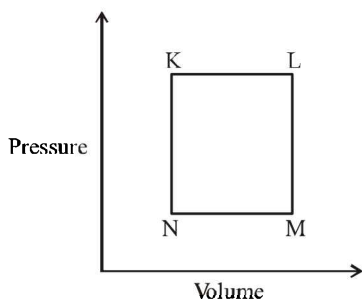

(JEE Adv. 2013)

- The succeeding operations that enable this transformation of states are
  - Heating, cooling, heating, cooling
  - Cooling, heating, cooling, heating
  - Heating, cooling, cooling, heating
  - Cooling, heating, heating, cooling
- The pair of isochoric processes among the transformation of states is
  - K to L and L to M
  - L to M and N to K
  - L to M and M to N
  - M to N and N to K

### H Assertion & Reason Type Questions

- Read the following statement and explanation and answer as per the options given below :

**Assertion :** The heat absorbed during the isothermal expansion of an ideal gas against vacuum is zero.

**Reason :** The volume occupied by the molecules of an ideal gas is zero. (2000S)

- If both assertion and reason are CORRECT, and reason is the CORRECT explanation of the assertion.
- If both assertion and reason are CORRECT, but reason is NOT the CORRECT explanation of the assertion.

- If assertion is CORRECT, but reason is INCORRECT.
- If assertion is INCORRECT, but reason is CORRECT.

**Statement - 1 :** There is a natural asymmetry between converting work to heat and converting heat to work. and  
**Statement - 2 :** No process is possible in which the sole result is the absorption of heat from a reservoir and its complete conversion into work. (2008S)

- Statement-1 is True, Statement-2 is True; Statement-2 is a correct explanation for Statement-1.
- Statement-1 is True, Statement-2 is True; Statement-2 is NOT a correct explanation for Statement-1
- Statement-1 is True, Statement-2 is False
- Statement-1 is False, Statement-2 is True

### I Integer Value Correct Type

- In a constant volume calorimeter, 3.5 g of a gas with molecular weight 28 was burnt in excess oxygen at 298.0 K. The temperature of the calorimeter was found to increase from 298.0 K to 298.45 K due to the combustion process. Given that the heat capacity of the calorimeter is  $2.5 \text{ kJ K}^{-1}$ , the numerical value for the enthalpy of combustion of the gas in  $\text{kJ mol}^{-1}$  is (2009 - 6M)
- One mole of an ideal gas is taken from  $a$  to  $b$  along two paths denoted by the solid and the dashed lines as shown in the graphs below. If the work done along the solid line path  $w_s$  and that along the dotted line path is  $w_d$ , then the integer closest to the ratio  $w_d/w_s$  is : (2010)

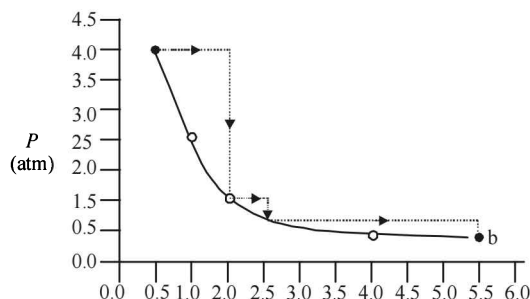

## Section-B

## JEE Main / AIEEE

- If an endothermic reaction is non-spontaneous at freezing point of water and becomes feasible at its boiling point, then
  - $\Delta H$  is -ve,  $\Delta S$  is +ve [2002]
  - $\Delta H$  and  $\Delta S$  both are +ve
  - $\Delta H$  and  $\Delta S$  both are -ve
  - $\Delta H$  is +ve,  $\Delta S$  is -ve
- A heat engine absorbs heat  $Q_1$  at temperature  $T_1$  and heat  $Q_2$  at temperature  $T_2$ . Work done by the engine is  $J(Q_1 + Q_2)$ . This data [2002]
  - violates 1<sup>st</sup> law of thermodynamics
  - violates 1<sup>st</sup> law of thermodynamics if  $Q_1$  is -ve
  - violates 1<sup>st</sup> law of thermodynamics of  $Q_2$  is -ve
  - does not violate 1<sup>st</sup> law of thermodynamics.
- For the reactions, [2002]
 
$$2C + O_2 \rightarrow 2CO_2; \quad \Delta H = -393 \text{ J}$$

$$2Zn + O_2 \rightarrow 2ZnO; \quad \Delta H = -412 \text{ J}$$
  - carbon can oxidise Zn
  - oxidation of carbon is not feasible
  - oxidation of Zn is not feasible
  - Zn can oxidise carbon.
- The heat required to raise the temperature of body by 1 K is called [2002]
  - specific heat
  - thermal capacity
  - water equivalent
  - none of these.
- The internal energy change when a system goes from state A to B is 40 kJ/mole. If the system goes from A to B by a reversible path and returns to state A by an irreversible path what would be the net change in internal energy? [2003]
  - > 40 kJ
  - < 40 kJ
  - Zero
  - 40 kJ
- If at 298 K the bond energies of C—H, C—C, C=C and H—H bonds are respectively 414, 347, 615 and 435 kJ mol<sup>-1</sup>, the value of enthalpy change for the reaction
 
$$H_2C = CH_2(g) + H_2(g) \rightarrow H_3C - CH_3(g)$$
 at 298 K will be [2003]
  - 250 kJ
  - +125 kJ
  - 125 kJ
  - +250 kJ
- In an irreversible process taking place at constant T and P and in which only pressure-volume work is being done, the change in Gibbs free energy ( $dG$ ) and change in entropy ( $dS$ ), satisfy the criteria [2003]
  - $(dS)_{V,E} > 0, (dG)_{T,P} < 0$
  - $(dS)_{V,E} = 0, (dG)_{T,P} = 0$
  - $(dS)_{V,E} = 0, (dG)_{T,P} > 0$
  - $(dS)_{V,E} < 0, (dG)_{T,P} < 0$
- The correct relationship between free energy change in a reaction and the corresponding equilibrium constant  $K_c$  is [2003]
  - $-\Delta G = RT \ln K_c$
  - $\Delta G^\circ = RT \ln K_c$
  - $-\Delta G^\circ = RT \ln K_c$
  - $\Delta G = RT \ln K_c$
- The enthalpy change for a reaction does not depend upon [2003]
  - use of different reactants for the same product
  - the nature of intermediate reaction steps
  - the differences in initial or final temperatures of involved substances
  - the physical states of reactants and products
- An ideal gas expands in volume from  $1 \times 10^{-3}$  to  $1 \times 10^{-2}$  m<sup>3</sup> at 300 K against a constant pressure of  $1 \times 10^5$  Nm<sup>-2</sup>. The work done is [2004]
  - 270 kJ
  - 900 kJ
  - 900
  - 900 kJ
- The enthalpies of combustion of carbon and carbon monoxide are -393.5 and -283 kJ mol<sup>-1</sup> respectively. The enthalpy of formation of carbon monoxide per mole is [2004]
  - 676.5 kJ
  - 676.5 kJ
  - 110.5 kJ
  - 110.5 kJ
- Consider an endothermic reaction  $X \rightarrow Y$  with the activation energies  $E_b$  and  $E_f$  for the backward and forward reactions, respectively. In general [2005]
  - there is no definite relation between  $E_b$  and  $E_f$
  - $E_b = E_f$
  - $E_b > E_f$
  - $E_b < E_f$
- Consider the reaction:  $N_2 + 3H_2 \rightarrow 2NH_3$  carried out at constant temperature and pressure. If  $\Delta H$  and  $\Delta U$  are the enthalpy and internal energy changes for the reaction, which of the following expressions is true? [2005]
  - $\Delta H > \Delta U$
  - $\Delta H < \Delta U$
  - $\Delta H = \Delta U$
  - $\Delta H = 0$
- If the bond dissociation energies of XY, X<sub>2</sub> and Y<sub>2</sub> (all diatomic molecules) are in the ratio of 1 : 1 : 0.5 and  $\Delta H_f$  for the formation of XY is -200 kJ mole<sup>-1</sup>. The bond dissociation energy of X<sub>2</sub> will be [2005]
  - 400 kJ mol<sup>-1</sup>
  - 300 kJ mol<sup>-1</sup>
  - 200 kJ mol<sup>-1</sup>
  - 100 kJ mol<sup>-1</sup>

15. An ideal gas is allowed to expand both reversibly and irreversibly in an isolated system. If  $T_i$  is the initial temperature and  $T_f$  is the final temperature, which of the following statements is correct? [2006]
- $(T_f)_{\text{rev}} = (T_f)_{\text{irrev}}$
  - $T_f = T_i$  for both reversible and irreversible processes
  - $(T_f)_{\text{irrev}} > (T_f)_{\text{rev}}$
  - $T_f > T_i$  for reversible process but  $T_f = T_i$  for irreversible process
16. The standard enthalpy of formation ( $\Delta_f H^\circ$ ) at 298 K for methane,  $\text{CH}_4(\text{g})$  is  $-74.8 \text{ kJ mol}^{-1}$ . The additional information required to determine the average energy for C – H bond formation would be [2006]
- the first four ionization energies of carbon and electron gain enthalpy of hydrogen
  - the dissociation energy of hydrogen molecule,  $\text{H}_2$
  - the dissociation energy of  $\text{H}_2$  and enthalpy of sublimation of carbon
  - latent heat of vapourization of methane
17. The enthalpy changes for the following processes are listed below : [2006]
- |  |                             |
|--|-----------------------------|
| $\text{Cl}_2(\text{g}) \rightarrow 2\text{Cl}(\text{g}),$                    | $242.3 \text{ kJ mol}^{-1}$ |
| $\text{I}_2(\text{g}) \rightarrow 2\text{I}(\text{g}),$                      | $151.0 \text{ kJ mol}^{-1}$ |
| $\text{ICl}(\text{g}) \rightarrow \text{I}(\text{g}) + \text{Cl}(\text{g}),$ | $211.3 \text{ kJ mol}^{-1}$ |
| $\text{I}_2(\text{s}) \rightarrow \text{I}_2(\text{g}),$                     | $62.76 \text{ kJ mol}^{-1}$ |
- Given that the standard states for iodine and chlorine are  $\text{I}_2(\text{s})$  and  $\text{Cl}_2(\text{g})$ , the standard enthalpy of formation for  $\text{ICl}(\text{g})$  is : [2006]
- $+16.8 \text{ kJ mol}^{-1}$
  - $+244.8 \text{ kJ mol}^{-1}$
  - $-14.6 \text{ kJ mol}^{-1}$
  - $-16.8 \text{ kJ mol}^{-1}$
18.  $(\Delta H - \Delta U)$  for the formation of carbon monoxide (CO) from its elements at 298 K is [2006]
- $(R = 8.314 \text{ J K}^{-1} \text{ mol}^{-1})$
- $-2477.57 \text{ J mol}^{-1}$
  - $2477.57 \text{ J mol}^{-1}$
  - $-1238.78 \text{ J mol}^{-1}$
  - $1238.78 \text{ J mol}^{-1}$
19. In conversion of lime-stone to lime,
- $\text{CaCO}_3(\text{s}) \rightarrow \text{CaO}(\text{s}) + \text{CO}_2(\text{g})$  the values of  $\Delta H^\circ$  and  $\Delta S^\circ$  are  $+179.1 \text{ kJ mol}^{-1}$  and  $160.2 \text{ J/K}$  respectively at 298 K and 1 bar. Assuming that  $\Delta H^\circ$  and  $\Delta S^\circ$  do not change with temperature, temperature above which conversion of limestone to lime will be spontaneous is [2007]
- 1118 K
  - 1008 K
  - 1200 K
  - 845 K
20. Assuming that water vapour is an ideal gas, the internal energy change ( $\Delta U$ ) when 1 mol of water is vapourised at 1 bar pressure and  $100^\circ\text{C}$ , (given : molar enthalpy of vapourisation of water at 1 bar and  $373 \text{ K} = 41 \text{ kJ mol}^{-1}$  and  $R = 8.3 \text{ J mol}^{-1} \text{ K}^{-1}$ ) will be [2007]
- $41.00 \text{ kJ mol}^{-1}$
  - $4.100 \text{ kJ mol}^{-1}$
  - $3.7904 \text{ kJ mol}^{-1}$
  - $37.904 \text{ kJ mol}^{-1}$
21. Identify the correct statement regarding a spontaneous process: [2007]
- Lowering of energy in the process is the only criterion for spontaneity.
  - For a spontaneous process in an isolated system, the change in entropy is positive.
  - Endothermic processes are never spontaneous.
  - Exothermic processes are always spontaneous.
22. Oxidising power of chlorine in aqueous solution can be determined by the parameters indicated below:
- $$\frac{1}{2}\text{Cl}_2(\text{g}) \xrightarrow{\frac{1}{2}\Delta_{\text{diss}}H^\ominus} \text{Cl}(\text{g}) \xrightarrow{\Delta_{\text{eg}}H^\ominus} \text{Cl}^-(\text{g})$$
- $$\xrightarrow{\Delta_{\text{Hyd}}H^\ominus} \text{Cl}^-(\text{aq})$$
- (using the data,
- $\Delta_{\text{diss}}H_{\text{Cl}_2}^\ominus = 240 \text{ kJ mol}^{-1}$ ,  $\Delta_{\text{eg}}H_{\text{Cl}}^\ominus = -349 \text{ kJ mol}^{-1}$ ,
- $\Delta_{\text{hyd}}H_{\text{Cl}^-}^\ominus = -381 \text{ kJ mol}^{-1}$ ), will be [2008]
- $+152 \text{ kJ mol}^{-1}$
  - $-610 \text{ kJ mol}^{-1}$
  - $-850 \text{ kJ mol}^{-1}$
  - $+120 \text{ kJ mol}^{-1}$
23. Standard entropy of  $\text{X}_2$ ,  $\text{Y}_2$  and  $\text{XY}_3$  are 60, 40 and  $50 \text{ J K}^{-1} \text{ mol}^{-1}$ , respectively. For the reaction,
- $$\frac{1}{2}\text{X}_2 + \frac{3}{2}\text{Y}_2 \rightarrow \text{XY}_3, \Delta H = -30 \text{ kJ}$$
- to be at equilibrium, the temperature will be [2008]
- 1250 K
  - 500 K
  - 750 K
  - 1000 K
24. On the basis of the following thermochemical data : [2009]
- $(\Delta_f G^\ominus_{\text{H}^+(\text{aq})} = 0)$
- $\text{H}_2\text{O}(\text{l}) \rightarrow \text{H}^+(\text{aq}) + \text{OH}^-(\text{aq}); \Delta H = 57.32 \text{ kJ}$
- $\text{H}_2(\text{g}) + \frac{1}{2}\text{O}_2(\text{g}) \longrightarrow \text{H}_2\text{O}(\text{l}); \Delta H = -286.20 \text{ kJ}$
- The value of enthalpy of formation of  $\text{OH}^-$  ion at  $25^\circ\text{C}$  is:
- $-228.88 \text{ kJ}$
  - $+228.88 \text{ kJ}$
  - $-343.52 \text{ kJ}$
  - $-22.88 \text{ kJ}$
25. The standard enthalpy of formation of  $\text{NH}_3$  is  $-46.0 \text{ kJ mol}^{-1}$ . If the enthalpy of formation of  $\text{H}_2$  from its atoms is  $-436 \text{ kJ mol}^{-1}$  and that of  $\text{N}_2$  is  $-712 \text{ kJ mol}^{-1}$ , the average bond enthalpy of N – H bond in  $\text{NH}_3$  is [2010]
- $-964 \text{ kJ mol}^{-1}$
  - $+352 \text{ kJ mol}^{-1}$
  - $+1056 \text{ kJ mol}^{-1}$
  - $-1102 \text{ kJ mol}^{-1}$
26. For a particular reversible reaction at temperature  $T$ ,  $\Delta H$  and  $\Delta S$  were found to be both +ve. If  $T_e$  is the temperature at equilibrium, the reaction would be spontaneous when [2010]
- $T_e > T$
  - $T > T_e$
  - $T_e$  is 5 times  $T$
  - $T = T_e$

27. The entropy change involved in the isothermal reversible expansion of 2 mole of an ideal gas from a volume of  $10 \text{ dm}^3$  to a volume of  $100 \text{ dm}^3$  at  $27^\circ\text{C}$  is: [2011]  
 (a)  $38.3 \text{ J mol}^{-1} \text{ K}^{-1}$  (b)  $35.8 \text{ J mol}^{-1} \text{ K}^{-1}$   
 (b)  $32.3 \text{ J mol}^{-1} \text{ K}^{-1}$  (d)  $42.3 \text{ J mol}^{-1} \text{ K}^{-1}$
28. The incorrect expression among the following is: [2012]  
 (a)  $\frac{\Delta G_{\text{system}}}{\Delta S_{\text{total}}} = -T$   
 (b) In isothermal process,  $w_{\text{reversible}} = -nRT \ln \frac{V_f}{V_i}$   
 (c)  $\ln K = \frac{\Delta H^\circ - T\Delta S^\circ}{RT}$  (d)  $K = e^{-\Delta G^\circ/RT}$
29. A piston filled with 0.04 mol of an ideal gas expands reversibly from 50.0 mL to 375 mL at a constant temperature of  $37.0^\circ\text{C}$ . As it does so, it absorbs 208 J of heat. The values of  $q$  and  $w$  for the process will be: [JEE M 2013]  
 ( $R = 8.314 \text{ J/mol K}$ ) ( $\ln 7.5 = 2.01$ )  
 (a)  $q = +208 \text{ J}$ ,  $w = -208 \text{ J}$  (b)  $q = -208 \text{ J}$ ,  $w = -208 \text{ J}$   
 (c)  $q = -208 \text{ J}$ ,  $w = +208 \text{ J}$  (d)  $q = +208 \text{ J}$ ,  $w = +208 \text{ J}$
30. For complete combustion of ethanol,  
 $\text{C}_2\text{H}_5\text{OH}(l) + 3\text{O}_2(g) \longrightarrow 2\text{CO}_2(g) + 3\text{H}_2\text{O}(l)$ ,  
 the amount of heat produced as measured in bomb calorimeter, is  $1364.47 \text{ kJ mol}^{-1}$  at  $25^\circ\text{C}$ . Assuming ideality the enthalpy of combustion,  $\Delta_c H$ , for the reaction will be:  
 ( $R = 8.314 \text{ kJ mol}^{-1}$ ) [JEE M 2014]  
 (a)  $-1366.95 \text{ kJ mol}^{-1}$  (b)  $-1361.95 \text{ kJ mol}^{-1}$   
 (c)  $-1460.95 \text{ kJ mol}^{-1}$  (d)  $-1350.50 \text{ kJ mol}^{-1}$
31. The heats of combustion of carbon and carbon monoxide are  $-393.5$  and  $-283.5 \text{ kJ mol}^{-1}$ , respectively. The heat of formation (in kJ) of carbon monoxide per mole is: [JEE M 2016]  
 (a)  $-676.5$  (b)  $-110.5$   
 (c)  $110.5$  (d)  $676.5$



## CHAPTER

## 7

## Equilibrium

## Section-A

## JEE Advanced/ IIT-JEE

## A Fill in the Blanks

- The conjugate base of  $\text{HSO}_4^-$  in aqueous solution is .....  
(1982 - 1 Mark)
- An element which can exist as a positive ion in acidic solution and also as a negative ion in basic solution is said to be .....  
(1984 - 1 Mark)
- For a given reversible reaction at a fixed temperature, equilibrium constants  $K_p$  and  $K_c$  are related by.....  
(1994 - 1 Mark)
- A ten-fold increase in pressure on the reaction,  
 $\text{N}_2(\text{g}) + 3\text{H}_2(\text{g}) \rightleftharpoons 2\text{NH}_3(\text{g})$  at equilibrium results in .... in  $K_p$ .  
(1996 - 1 Mark)
- In the reaction  $\text{I}^- + \text{I}_2 \rightarrow \text{I}_3^-$ , the Lewis acid is .....  
(1997 - 1 Mark)

## B True / False

- Aluminium chloride ( $\text{AlCl}_3$ ) is a Lewis acid because it can donate electrons.  
(1982 - 1 Mark)
- If equilibrium constant for the reaction  $\text{A}_2 + \text{B}_2 \rightleftharpoons 2\text{AB}$ , is  $K$ , then for the backward reaction  $\text{AB} \rightleftharpoons \frac{1}{2}\text{A}_2 + \frac{1}{2}\text{B}_2$ , the equilibrium constant is  $1/K$ .  
(1984 - 1 Mark)
- When a liquid and its vapour are at equilibrium and the pressure is suddenly decreased, cooling occurs.  
(1984 - 1 Mark)
- Solubility of sodium hydroxide increases with increase in temperature.  
(1985 - 1/2 Mark)

## C MCQs with One Correct Answer

- Molten sodium chloride conducts electricity due to the presence of  
(1981 - 1 Mark)
  - free electrons
  - free ions
  - free molecules
  - atoms of sodium and chlorine
- An acidic buffer solution can be prepared by mixing the solutions of  
(1981 - 1 Mark)
  - ammonium acetate and acetic acid
  - ammonium chloride and ammonium hydroxide
  - sulphuric acid and sodium sulphate
  - sodium chloride and sodium hydroxide.
- The pH of a  $10^{-8}$  molar solution of HCl in water is  
(1981 - 1 Mark)
  - 8
  - 8
  - between 7 and 8
  - between 6 and 7
- The oxidation of  $\text{SO}_2$  by  $\text{O}_2$  to  $\text{SO}_3$  is an exothermic reaction. The yield of  $\text{SO}_3$  will be maximum if  
(1981 - 1 Mark)
  - temperature is increased and pressure is kept constant
  - temperature is reduced and pressure is increased
  - both temperature and pressure are increased
  - both temperature and pressure are reduced
- For the reaction :  
 $\text{H}_2(\text{g}) + \text{I}_2(\text{g}) \rightleftharpoons 2\text{HI}(\text{g})$   
the equilibrium constant  $K_p$  changes with  
(1981 - 1 Mark)
  - total pressure
  - catalyst
  - the amounts of  $\text{H}_2$  and  $\text{I}_2$  present
  - temperature
- Of the given anions, the strongest Bronsted base is  
(1981 - 1 Mark)
  - $\text{ClO}^-$
  - $\text{ClO}_2^-$
  - $\text{ClO}_3^-$
  - $\text{ClO}_4^-$
- At  $90^\circ\text{C}$ , pure water has  $[\text{H}_3\text{O}^+] 10^{-6}$  mole litre $^{-1}$ . What is the value of  $K_w$  at  $90^\circ\text{C}$ ?  
(1981 - 1 Mark)
  - $10^{-6}$
  - $10^{-12}$
  - $10^{-14}$
  - $10^{-8}$
- The precipitate of  
 $\text{CaF}_2 (K_{sp} = 1.7 \times 10^{-10})$   
is obtained when equal volumes of the following are mixed  
(1982 - 1 Mark)
  - $10^{-4}\text{M Ca}^{2+} + 10^{-4}\text{M F}^-$
  - $10^{-2}\text{M Ca}^{2+} + 10^{-3}\text{M F}^-$
  - $10^{-5}\text{M Ca}^{2+} + 10^{-3}\text{M F}^-$
  - $10^{-3}\text{M Ca}^{2+} + 10^{-5}\text{M F}^-$
- A liquid is in equilibrium with its vapour at its boiling point. On the average, the molecules in the two phases have equal :  
(1984 - 1 Mark)
  - inter-molecular forces
  - potential energy
  - total energy
  - kinetic energy

10. Pure ammonia is placed in a vessel at a temperature where its dissociation constant ( $a$ ) is appreciable. At equilibrium : (1984 - 1 Mark)
- $K_p$  does not change significantly with pressure.
  - does not change with pressure.
  - concentration of  $\text{NH}_3$  does not change with pressure.
  - concentration of hydrogen is less than that of nitrogen.
11. A certain buffer solution contains equal concentration of  $\text{X}^-$  and  $\text{HX}$ . The  $K_b$  for  $\text{X}^-$  is  $10^{-10}$ . The pH of the buffer is : (1984 - 1 Mark)
- 4
  - 7
  - 10
  - 14
12. A certain weak acid has a dissociation constant of  $1.0 \times 10^{-4}$ . The equilibrium constant for its reaction with a strong base is : (1984 - 1 Mark)
- $1.0 \times 10^{-4}$
  - $1.0 \times 10^{-10}$
  - $1.0 \times 10^{10}$
  - $1.0 \times 10^{14}$
13. An example of a reversible reaction is : (1985 - 1 Mark)
- $\text{Pb}(\text{NO}_3)_2(\text{aq}) + 2\text{NaI}(\text{aq}) \rightarrow \text{PbI}_2(\text{s}) + 2\text{NaNO}_3(\text{aq})$
  - $\text{AgNO}_3(\text{aq}) + \text{HCl}(\text{aq}) \rightarrow \text{AgCl}(\text{s}) + \text{NaNO}_3(\text{aq})$
  - $2\text{Na}(\text{s}) + \text{H}_2\text{O}(\text{l}) \rightarrow 2\text{NaOH}(\text{aq}) + \text{H}_2(\text{g})$
  - $\text{KNO}_3(\text{aq}) + \text{NaCl}(\text{aq}) \rightarrow \text{KCl}(\text{aq}) + \text{NaNO}_3(\text{aq})$
14. The best indicator for detection of end point in titration of a weak acid and a strong base is : (1985 - 1 Mark)
- methyl orange (3 to 4)
  - methyl red (5 to 6)
  - bromothymol blue (6 to 7.5)
  - phenolphthalein (8 to 9.6)
15. The conjugate acid of  $\text{NH}_2^-$  is : (1985 - 1 Mark)
- $\text{NH}_3$
  - $\text{NH}_2\text{OH}$
  - $\text{NH}_4^+$
  - $\text{N}_2\text{H}_4$
16. The compound that is not a Lewis acid is : (1985 - 1 Mark)
- $\text{BF}_3$
  - $\text{AlCl}_3$
  - $\text{BeCl}_2$
  - $\text{SnCl}_4$
17. The compound insoluble in acetic acid is : (1986 - 1 Mark)
- calcium oxide
  - calcium carbonate
  - calcium oxalate
  - calcium hydroxide
18. The compound whose 0.1 M solution is basic is : (1986 - 1 Mark)
- ammonium acetate
  - ammonium chloride
  - ammonium sulphate
  - sodium acetate
19. When equal volumes of the following solutions are mixed, precipitation of  $\text{AgCl}$  ( $K_{sp} = 1.8 \times 10^{-10}$ ) will occur only with (1988 - 1 Mark)
- $10^{-4} \text{ M}(\text{Ag}^+)$  and  $10^{-4} \text{ M}(\text{Cl}^-)$
  - $10^{-5} \text{ M}(\text{Ag}^+)$  and  $10^{-5} \text{ M}(\text{Cl}^-)$
  - $10^{-6} \text{ M}(\text{Ag}^+)$  and  $10^{-6} \text{ M}(\text{Cl}^-)$
  - $10^{-10} \text{ M}(\text{Ag}^+)$  and  $10^{-10} \text{ M}(\text{Cl}^-)$
20. The  $pK_a$  of acetylsalicylic acid (aspirin) is 3.5. The pH of gastric juice in human stomach is about 2-3 and the pH in the small intestine is about 8. Aspirin will be (1988 - 1 Mark)
- unionised in the small intestine and in the stomach
  - completely ionised in the small intestine and in the stomach
  - ionised in the stomach and almost unionised in the small intestine
  - ionised in the small intestine and almost unionised in the stomach.
21. Which one of the following is the strongest acid? (1989 - 1 Mark)
- $\text{ClO}_3(\text{OH})$
  - $\text{ClO}_2(\text{OH})$
  - $\text{SO}(\text{OH})_2$
  - $\text{SO}_2(\text{OH})_2$
22. Amongst the following hydroxides, the one which has the lowest value of  $K_{sp}$  at ordinary temperature (about  $25^\circ\text{C}$ ) is (1990 - 1 Mark)
- $\text{Mg}(\text{OH})_2$
  - $\text{Ca}(\text{OH})_2$
  - $\text{Ba}(\text{OH})_2$
  - $\text{Be}(\text{OH})_2$
23. The reaction which proceeds in the forward direction is (1991 - 1 Mark)
- $\text{Fe}_2\text{O}_3 + 6\text{HCl} \rightarrow 2\text{FeCl}_3 + 3\text{H}_2\text{O}$
  - $\text{NH}_3 + \text{H}_2\text{O} + \text{NaCl} \rightarrow \text{NH}_4\text{Cl} + \text{NaOH}$
  - $\text{SnCl}_4 + \text{Hg}_2\text{Cl}_2 \rightarrow \text{SnCl}_2 + 2\text{HgCl}_2$
  - $2\text{CuI} + \text{I}_2 + 4\text{K}^+ \rightarrow 2\text{Cu}^{2+} + 4\text{KI}$
24. The following equilibrium is established when hydrogen chloride is dissolved in acetic acid.
- $$\text{HCl} + \text{CH}_3\text{COOH} \rightleftharpoons \text{Cl}^- + \text{CH}_3\text{COOH}_2^+$$
- The set that characterises the conjugate acid-base pairs is (1992 - 1 Mark)
- ( $\text{HCl}$ ,  $\text{CH}_3\text{COOH}$ ) and ( $\text{CH}_3\text{COOH}_2^+$ ,  $\text{Cl}^-$ )
  - ( $\text{HCl}$ ,  $\text{CH}_3\text{COOH}_2^+$ ) and ( $\text{CH}_3\text{COOH}$ ,  $\text{Cl}^-$ )
  - ( $\text{CH}_3\text{COOH}_2^+$ ,  $\text{HCl}$ ) and ( $\text{Cl}^-$ ,  $\text{CH}_3\text{COOH}$ )
  - ( $\text{HCl}$ ,  $\text{Cl}^-$ ) and ( $\text{CH}_3\text{COOH}_2^+$ ,  $\text{CH}_3\text{COOH}$ )
25. Which of the following solutions will have pH close to 1.0? (1992 - 1 Mark)
- 100 ml of (M/10)  $\text{HCl}$  + 100 ml of (M/10)  $\text{NaOH}$
  - 55 ml of (M/10)  $\text{HCl}$  + 45 ml of (M/10)  $\text{NaOH}$
  - 10 ml of (M/10)  $\text{HCl}$  + 90 ml of (M/10)  $\text{NaOH}$
  - 75 ml of (M/5)  $\text{HCl}$  + 25 ml of (M/5)  $\text{NaOH}$
26. The degree of dissociation of water at  $25^\circ\text{C}$  is  $1.9 \times 10^{-7}\%$  and density is  $1.0 \text{ g cm}^{-3}$ . The ionic constant for water is : (1995S)
- $1.0 \times 10^{-10}$
  - $1.0 \times 10^{-14}$
  - $1.0 \times 10^{-16}$
  - $1.0 \times 10^{-8}$
27. Which one is more acidic in aqueous solution. (1995S)
- $\text{NiCl}_2$
  - $\text{FeCl}_3$
  - $\text{AlCl}_3$
  - $\text{BeCl}_2$
28. The following acids have been arranged in the order of decreasing acid strength. Identify the correct order. (1996 - 1 Mark)
- $$\text{ClOH}(\text{I}), \text{BrOH}(\text{II}), \text{IOH}(\text{III})$$
- $\text{I} > \text{II} > \text{III}$
  - $\text{II} > \text{I} > \text{III}$
  - $\text{III} > \text{II} > \text{I}$
  - $\text{I} > \text{III} > \text{II}$

29. The pH of 0.1 M solution of the following salts increases in the order. (1999 - 2 Marks)
- $\text{NaCl} < \text{NH}_4\text{Cl} < \text{NaCN} < \text{HCl}$
  - $\text{HCl} < \text{NH}_4\text{Cl} < \text{NaCl} < \text{NaCN}$
  - $\text{NaCN} < \text{NH}_4\text{Cl} < \text{NaCl} < \text{HCl}$
  - $\text{HCl} < \text{NaCl} < \text{NaCN} < \text{NH}_4\text{Cl}$
30. For the chemical reaction  $3\text{X}(\text{g}) + \text{Y}(\text{g}) \rightleftharpoons \text{X}_3\text{Y}(\text{g})$ , the amount of  $\text{X}_3\text{Y}$  at equilibrium is affected by (1999 - 2 Marks)
- temperature and pressure
  - temperature only
  - pressure only
  - temperature, pressure and catalyst
31. For the reversible reaction,  $\text{N}_2(\text{g}) + 3\text{H}_2(\text{g}) \rightleftharpoons 2\text{NH}_3(\text{g})$  at  $500^\circ\text{C}$ , the value of  $K_p$  is  $1.44 \times 10^{-5}$  when partial pressure is measured in atmospheres. The corresponding value of  $K_c$ , with concentration in mole litre<sup>-1</sup>, is (2000S)
- $\frac{1.44 \times 10^{-5}}{(0.082 \times 500)^2}$
  - $\frac{1.44 \times 10^{-5}}{(8.314 \times 773)^2}$
  - $\frac{1.44 \times 10^{-5}}{(0.082 \times 773)^2}$
  - $\frac{1.44 \times 10^{-5}}{(0.082 \times 773)^2}$
32. When two reactants,  $A$  &  $B$  are mixed to give products  $C$  &  $D$ , the reaction quotient  $Q$ , at the initial stages of the reaction (2000S)
- is zero
  - decreases with time
  - is independent of time
  - increases with time
33. The set with correct order of acidity is (2001S)
- $\text{HClO} < \text{HClO}_2 < \text{HClO}_3 < \text{HClO}_4$
  - $\text{HClO}_4 < \text{HClO}_3 < \text{HClO}_2 < \text{HClO}$
  - $\text{HClO} < \text{HClO}_4 < \text{HClO}_3 < \text{HClO}_2$
  - $\text{HClO}_4 < \text{HClO}_2 < \text{HClO}_3 < \text{HClO}$
34. For a sparingly soluble salt  $A_pB_q$ , the relationship of its solubility product ( $L_S$ ) with its solubility ( $S$ ) is (2001S)
- $L_S = S^{p+q} \cdot p^p \cdot q^q$
  - $L_S = S^{p+q} \cdot p^q \cdot q^p$
  - $L_S = S^{pq} \cdot p^p \cdot q^q$
  - $L_S = S^{pq} \cdot (pq)^{p+q}$
35. At constant temperature, the equilibrium constant ( $K_p$ ) for the decomposition reaction  $\text{N}_2\text{O}_4 \rightleftharpoons 2\text{NO}_2$  is expressed by  $K_p = (4x^2P)/(1-x^2)$ , where  $P$  = pressure,  $x$  = extent of decomposition. Which one of the following statements is true? (2001S)
- $K_p$  increases with increase of  $P$
  - $K_p$  increases with increase of  $x$
  - $K_p$  increases with decrease of  $x$
  - $K_p$  remains constant with change in  $P$  and  $x$
36. Consider the following equilibrium in a closed container (2002S)
- $$\text{N}_2\text{O}_4(\text{g}) \rightleftharpoons 2\text{NO}_2(\text{g})$$
- At a fixed temperature, the volume of the reaction container is halved. For this change, which of the following statements holds true regarding the equilibrium constant ( $K_p$ ) and degree of dissociation ( $\alpha$ )?
- neither  $K_p$  nor  $\alpha$  changes
  - both  $K_p$  and  $\alpha$  change
  - $K_p$  changes, but  $\alpha$  does not change
  - $K_p$  does not change, but  $\alpha$  changes
37. A weak acid HX has the dissociation constant  $1 \times 10^{-5}$  M. It forms a salt NaX on reaction with alkali. The percentage hydrolysis of 0.1 M solution of NaX is (2004S)
- 0.0001%
  - 0.01%
  - 0.1%
  - 0.15%
38. A 0.004 M solution of  $\text{Na}_2\text{SO}_4$  is isotonic with 0.010 M solution of glucose at same temperature. The percentage dissociation of  $\text{Na}_2\text{SO}_4$  is (2004S)
- 25%
  - 50%
  - 75%
  - 85%
39. 0.1 mole of  $\text{CH}_3\text{NH}_2$  ( $K_b = 5 \times 10^{-4}$ ) is mixed with 0.08 mole of HCl and diluted to one litre. What will be the  $\text{H}^+$  concentration in the solution? (2005S)
- $8 \times 10^{-2}$  M
  - $8 \times 10^{-11}$  M
  - $1.6 \times 10^{-11}$  M
  - $8 \times 10^{-5}$  M
40. The Haber's process for the formation of  $\text{NH}_3$  at 298K is  $\text{N}_2 + 3\text{H}_2 \rightleftharpoons 2\text{NH}_3$ ;  $\Delta H = -46.0$  kJ; Which of the following is the correct statement (2006 - 3M, -1)
- The condition for equilibrium is  $G_{\text{N}_2} + 3G_{\text{H}_2} = 2G_{\text{NH}_3}$  where  $G$  is Gibb's free energy per mole of the gaseous species measured at that partial pressure.
  - On adding  $\text{N}_2$ , the equilibrium will shift to forward direction because according to II<sup>nd</sup> law of thermodynamics the entropy must increase in the direction of spontaneous reaction
  - The catalyst will increase the rate of forward reaction by 2 times and that of backward reaction by 1.5 times
  - None of these
41. 2.5 ml of (2/5) M weak monoacidic base ( $K_b = 1 \times 10^{-12}$  at  $25^\circ\text{C}$ ) is titrated (2/15) M HCl in water at  $25^\circ\text{C}$ . The concentration of  $\text{H}^+$  at equivalence point is ( $K_w = 1 \times 10^{-14}$  at  $25^\circ\text{C}$ ) (2008S)
- $3.7 \times 10^{-14}$  M
  - $3.2 \times 10^{-7}$  M
  - $3.2 \times 10^{-2}$  M
  - $2.7 \times 10^{-2}$  M
42. Solubility product constant ( $K_{sp}$ ) of salts of types  $\text{MX}$ ,  $\text{MX}_2$  and  $\text{M}_3\text{X}$  at temperature  $T$  are  $4.0 \times 10^{-8}$ ,  $3.2 \times 10^{-14}$  &  $2.7 \times 10^{-15}$ , respectively. Solubilities (mol dm<sup>-3</sup>) of the salts at temperature ' $T$ ' are in the order – (2008S)
- $\text{MX} > \text{MX}_2 > \text{M}_3\text{X}$
  - $\text{M}_3\text{X} > \text{MX}_2 > \text{MX}$
  - $\text{MX}_2 > \text{M}_3\text{X} > \text{MX}$
  - $\text{MX} > \text{M}_3\text{X} > \text{MX}_2$

**D MCQs with One or More Than One Correct**

- For the gas phase reaction : (1984 - 1 Mark)  

$$\text{C}_2\text{H}_4 + \text{H}_2 \rightleftharpoons \text{C}_2\text{H}_6 \quad (\Delta H = -32.7 \text{ kcal})$$
 carried out in a vessel, the equilibrium concentration of  $\text{C}_2\text{H}_4$  can be increased by :  
 (a) increasing the temperature  
 (b) decreasing the pressure  
 (c) removing some  $\text{H}_2$   
 (d) adding some  $\text{C}_2\text{H}_6$
- When  $\text{NaNO}_3$  is heated in a closed vessel, oxygen is liberated and  $\text{NaNO}_2$  is left behind. At equilibrium. (1986 - 1 Mark)  
 (a) addition of  $\text{NaNO}_2$  favours reverse reaction  
 (b) addition of  $\text{NaNO}_3$  favours forward reaction  
 (c) increasing temperature favours forward reaction  
 (d) increasing pressure favours reverse reaction
- The equilibrium : (1989 - 1 Mark)  

$$\text{SO}_2\text{Cl}_2(\text{g}) \rightleftharpoons \text{SO}_2(\text{g}) + \text{Cl}_2(\text{g})$$
 is attained at  $25^\circ\text{C}$  in a closed container and an inert gas, helium is introduced. Which of the following statements are correct?  
 (a) Concentration of  $\text{SO}_2$ ,  $\text{Cl}_2$  and  $\text{SO}_2\text{Cl}_2$  do not change  
 (b) More chlorine is formed  
 (c) Concentration of  $\text{SO}_2$  is reduced  
 (d) More  $\text{SO}_2\text{Cl}_2$  is formed.
- For the reaction : (1991 - 1 Mark)  

$$\text{PCl}_5(\text{g}) \rightarrow \text{PCl}_3(\text{g}) + \text{Cl}_2(\text{g})$$
 The forward reaction at constant temperature is favoured by  
 (a) introducing an inert gas at constant volume  
 (b) introducing chlorine gas at constant volume  
 (c) introducing an inert gas at constant pressure  
 (d) increasing the volume of the container  
 (e) introducing  $\text{PCl}_5$  at constant volume
- For the reaction  $\text{CO}(\text{g}) + \text{H}_2\text{O}(\text{g}) \rightleftharpoons \text{CO}_2(\text{g}) + \text{H}_2(\text{g})$  at a given temperature the equilibrium amount of  $\text{CO}_2(\text{g})$  can be increased by (1998 - 2 Marks)  
 (a) adding a suitable catalyst  
 (b) adding an inert gas  
 (c) decreasing the volume of the container  
 (d) increasing the amount of  $\text{CO}(\text{g})$ .
- Which of the following statements(s) is (are) correct? (1998 - 2 Marks)  
 (a) The pH of  $1.0 \times 10^{-8} \text{ M}$  solution of  $\text{HCl}$  is 8  
 (b) The conjugate base of  $\text{H}_2\text{PO}_4^-$  is  $\text{HPO}_4^{2-}$   
 (c) Autoprotolysis constant of water increases with temperature  
 (d) When a solution of a weak monoprotic acid is titrated against a strong base, at half-neutralisation point  $\text{pH} = (1/2) \text{p}K_a$ .
- A buffer solution can be prepared from a mixture of (1999 - 3 Marks)  
 (a) sodium acetate and acetic acid in water  
 (b) sodium acetate and hydrochloric acid in water  
 (c) ammonia and ammonium chloride in water  
 (d) ammonia and sodium hydroxide in water

- Aqueous solutions of  $\text{HNO}_3$ ,  $\text{KOH}$ ,  $\text{CH}_3\text{COOH}$  and  $\text{CH}_3\text{COONa}$  of identical concentrations are provided. The pair(s) of solutions which form a buffer upon mixing is(are) (2010)  
 (a)  $\text{HNO}_3$  and  $\text{CH}_3\text{COOH}$   
 (b)  $\text{KOH}$  and  $\text{CH}_3\text{COONa}$   
 (c)  $\text{HNO}_3$  and  $\text{CH}_3\text{COONa}$   
 (d)  $\text{CH}_3\text{COOH}$  and  $\text{CH}_3\text{COONa}$
- The initial rate of hydrolysis of methyl acetate (1M) by a weak acid ( $\text{HA}$ , 1M) is  $1/100^{\text{th}}$  of that of a strong acid ( $\text{HX}$ , 1M), at  $25^\circ\text{C}$ . The  $K_a$  of  $\text{HA}$  is (JEE Adv. 2013)  
 (a)  $1 \times 10^{-4}$  (b)  $1 \times 10^{-5}$   
 (c)  $1 \times 10^{-6}$  (d)  $1 \times 10^{-3}$
- The  $K_{sp}$  of  $\text{Ag}_2\text{CrO}_4$  is  $1.1 \times 10^{-12}$  at 298 K. The solubility (in mol/L) of  $\text{Ag}_2\text{CrO}_4$  in a 0.1 M  $\text{AgNO}_3$  solution is (JEE Adv. 2013)  
 (a)  $1.1 \times 10^{-11}$  (b)  $1.1 \times 10^{-10}$   
 (c)  $1.1 \times 10^{-12}$  (d)  $1.1 \times 10^{-9}$
- The thermal dissociation equilibrium of  $\text{CaCO}_3(\text{s})$  is studied under different conditions (JEE Adv. 2013)  

$$\text{CaCO}_3(\text{s}) \rightleftharpoons \text{CaO}(\text{s}) + \text{CO}_2(\text{g})$$
 For this equilibrium, the correct statement(s) is(are)  
 (a)  $\Delta H$  is dependent on T  
 (b) K is independent of the initial amount of  $\text{CaCO}_3$   
 (c) K is dependent on the pressure of  $\text{CO}_2$  at a given T  
 (d)  $\Delta H$  is independent of catalyst, if any
- The %yield of ammonia as a function of time in the reaction  $\text{N}_2(\text{g}) + 3\text{H}_2(\text{g}) \rightleftharpoons 2\text{NH}_3(\text{g})$ ,  $\Delta H < 0$  at (P,  $T_1$ ) is given below

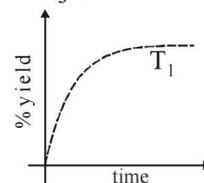

If this reaction is conducted at (P,  $T_2$ ), with  $T_2 > T_1$ , the %yield of ammonia as a function of time is represented by (JEE Adv. 2015)

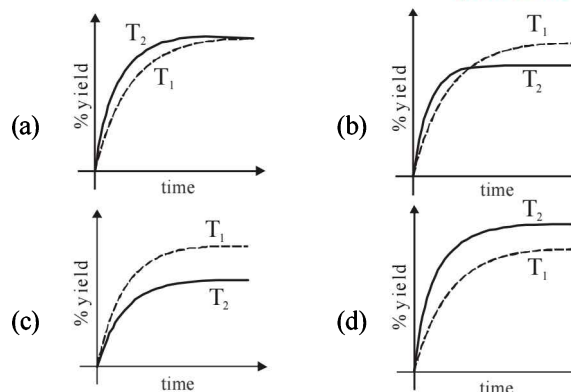
**E Subjective Problems**

- A solution contains  $\text{Na}_2\text{CO}_3$  and  $\text{NaHCO}_3$ . 10 ml of solution requires 2.5 ml of 0.1 M  $\text{H}_2\text{SO}_4$  for neutralisation using phenolphthalein as an indicator. Methyl orange is then added when a further 2.5 ml of 0.2 M  $\text{H}_2\text{SO}_4$  was required. Calculate the amount of  $\text{Na}_2\text{CO}_3$  and  $\text{NaHCO}_3$  in one litre of the solution. (1979)

2. How many moles of sodium propionate should be added to one litre of an aqueous solution containing 0.020 mole of propionic acid to obtain a buffer solution of pH 4.75? What will be pH if 0.010 mole of hydrogen chloride is dissolved in the above buffer solution. Compare the last pH value with the pH of 0.010 molar HCl solution. Dissociation constant of propionic acid,  $K_a$  at  $25^\circ\text{C} = 1.34 \times 10^{-5}$ .  
(1981 - 4 Marks)
3. One mole of nitrogen is mixed with three moles of hydrogen in a 4 litre container. If 0.25 per cent of nitrogen is converted to ammonia by the following reaction (1981 - 4 Marks)
- $$\text{N}_2(\text{g}) + 3\text{H}_2(\text{g}) \rightleftharpoons 2\text{NH}_3(\text{g}),$$
- calculate the equilibrium constant ( $K_c$ ) in concentration units. What will be the value of  $K_c$  for the following equilibrium?
- $$\frac{1}{2}\text{N}_2(\text{g}) + \frac{3}{2}\text{H}_2(\text{g}) \rightleftharpoons \text{NH}_3(\text{g})$$
4. Twenty ml. of 0.2 M sodium hydroxide is added to 50 ml. of 0.2 M acetic acid to give 70 ml of the solution. What is the pH of this solution? Calculate the additional volume of 0.2 M NaOH required to make the pH of the solution 4.74. The ionization constant of acetic acid is  $1.8 \times 10^{-5}$ .  
(1982 - 3 Marks)
5. The dissociation constant of a weak acid HA is  $4.9 \times 10^{-8}$ . After making the necessary approximations, calculate (i) percentage ionization, (ii) pH and (iii)  $\text{OH}^-$  concentration in a decimolar solution of the acid. Water has a pH of 7.  
(1983 - 2 Marks)
6. A solution contains a mixture of Ag (0.10 M) and  $\text{Hg}_2^{++}$  (0.10 M) which are to be separated by selective precipitation. Calculate the maximum concentration of iodide ion at which one of them gets precipitated almost completely. What percentage of that metal ion is precipitated?  
[ $K_{sp} : \text{AgI} = 8.5 \times 10^{-17}$ ;  $\text{Hg}_2\text{I}_2 = 2.5 \times 10^{-26}$ ]  
(1984 - 4 Marks)
7. One mole of  $\text{Cl}_2$  and 3 moles of  $\text{PCl}_5$  are placed in a 100 litre vessel heated to  $227^\circ\text{C}$ . The equilibrium pressure is 2.05 atmosphere. Assuming ideal behaviour, calculate the degree of dissociation for  $\text{PCl}_5$  and  $K_p$  for the reaction:  
 $\text{PCl}_5(\text{g}) \rightleftharpoons \text{PCl}_3(\text{g}) + \text{Cl}_2(\text{g})$ . (1984 - 6 Marks)
8. Arrange the following in:
- increasing bond length :  $\text{F}_2$ ,  $\text{N}_2$ ,  $\text{Cl}_2$ ,  $\text{O}_2$  (1985 - 1 Mark)
  - increasing acid strength :  $\text{HClO}_3$ ,  $\text{HClO}_4$ ,  $\text{HClO}_2$ ,  $\text{HClO}$  (1986 - 1 Mark)
  - increasing basicity :  $\text{H}_2\text{O}$ ,  $\text{OH}^-$ ,  $\text{CH}_3\text{OH}$ ,  $\text{CH}_3\text{O}^-$  (1992 - 1 Mark)
  - Arrange the following oxides in the decreasing order of Bronsted basicity :  
 $\text{BaO}$ ,  $\text{SO}_3$ ,  $\text{CO}_2$ ,  $\text{Cl}_2\text{O}_7$ ,  $\text{B}_2\text{O}_3$  (2004 - 2 Marks)
9. The  $[\text{H}^+]$  in 0.2 M solution of formic acid is  $6.4 \times 10^{-3}$  mole litre $^{-1}$ . To this solution sodium formate is added so as to adjust the concentration of sodium formate to one mole litre $^{-1}$ . What will be pH of this solution?  $K_a$  for  $\text{HCOOH}$  is  $2.4 \times 10^{-4}$  and degree of dissociation of  $\text{HCOONa}$  is 0.75.  
(1985 - 3 Marks)
10. The equilibrium constant of the reaction  
 $\text{A}_2(\text{g}) + \text{B}_2(\text{g}) \rightleftharpoons 2\text{AB}(\text{g})$   
at  $100^\circ\text{C}$  is 50. If a one litre flask containing one mole of  $\text{A}_2$  is connected to a two litre flask containing two mole of  $\text{B}_2$ , how many mole of AB will be formed at  $373^\circ\text{C}$ ?  
(1985 - 4 Marks)
11. The solubility of  $\text{Mg}(\text{OH})_2$  in pure water is  $9.57 \times 10^{-3}$  g/litre. Calculate its solubility (in g/litre) in 0.02 M  $\text{Mg}(\text{NO}_3)_2$  solution.  
(1986 - 5 Marks)
12. What is the pH of the solution when 0.20 mole of hydrochloric acid is added to one litre of a solution containing.  
(1987 - 5 Marks)
- 1 M each of acetic acid and acetate ion?
  - 0.1 M each of acetic acid and acetate ion?
- Assume the total volume is one litre.  
 $K_a$  for acetic acid =  $1.8 \times 10^{-5}$ .
13. At a certain temperature equilibrium constant ( $K_c$ ) is 16 for the reaction.  
(1987 - 5 Marks)
- $$\text{SO}_2(\text{g}) + \text{NO}_2(\text{g}) \rightleftharpoons \text{SO}_3(\text{g}) + \text{NO}(\text{g})$$
- If we take one mole each of all the four gases in a one litre container, what would be the equilibrium concentrations of  $\text{NO}(\text{g})$  and  $\text{NO}_2(\text{g})$ ?
14.  $\text{N}_2\text{O}_4$  is 25% dissociated at  $37^\circ\text{C}$  and one atmosphere pressure. Calculate (i)  $K_p$  and (ii) the percentage dissociation at 0.1 atmosphere and  $37^\circ\text{C}$ .  
(1988 - 4 Marks)
15. How many gram-mole of HCl will be required to prepare one litre of buffer solution (containing NaCN and HCl) of pH 8.5 using 0.01 gram formula weight of NaCN?  
 $K$  dissociation ( $\text{HCN}$ ) =  $4.1 \times 10^{-10}$ . (1988 - 4 Marks)
16. The equilibrium constant  $K_p$  of the reaction :  
 $2\text{SO}_2(\text{g}) + \text{O}_2(\text{g}) \rightleftharpoons 2\text{SO}_3(\text{g})$   
is 900 atm. at 800 K. A mixture containing  $\text{SO}_3$  and  $\text{O}_2$  having initial partial pressure of 1 and 2 atm. respectively is heated at constant volume to equilibrate. Calculate the partial pressure of each gas at 800 K. (1989 - 3 Marks)
17. Freshly precipitated aluminium and magnesium hydroxides are stirred vigorously in a buffer solution containing 0.25 mole/l of ammonium chloride and 0.05 mole/l of ammonium hydroxide. Calculate the concentration of aluminium and magnesium ions in solution: (1989 - 3 Marks)
- $$K_b[\text{NH}_4\text{OH}] = 1.80 \times 10^{-5}$$
- $$K_{sp}[\text{Mg}(\text{OH})_2] = 6 \times 10^{-10}$$
- $$K_{sp}[\text{Al}(\text{OH})_3] = 6 \times 10^{-32}$$
18. For the reaction :  $\text{CO}(\text{g}) + 2\text{H}_2(\text{g}) \rightleftharpoons \text{CH}_3\text{OH}(\text{g})$   
hydrogen gas is introduced into a five litre flask at  $327^\circ\text{C}$ , containing 0.2 mole of  $\text{CO}(\text{g})$  and a catalyst, until the pressure is 4.92 atm. At this point 0.1 mole of  $\text{CH}_3\text{OH}(\text{g})$  is formed. Calculate the equilibrium constant,  $K_p$  and  $K_c$ .  
(1990 - 5 Marks)
19. What is the pH of 1.0 M solution of acetic acid? To what volume must one liter of this solution be diluted so that the pH of the resulting solution will be twice the original value? Given :  $K_a = 1.8 \times 10^{-5}$ .  
(1990 - 4 Marks)
20. The solubility product of  $\text{Ag}_2\text{C}_2\text{O}_4$  at  $25^\circ\text{C}$  is  $1.29 \times 10^{-11}$  mol $^3$  l $^{-3}$ . A solution of  $\text{K}_2\text{C}_2\text{O}_4$  containing 0.1520 mole in 500 ml water is shaken at  $25^\circ\text{C}$  with excess of  $\text{Ag}_2\text{CO}_3$  till the following equilibrium is reached : (1991 - 4 Marks)
- $$\text{Ag}_2\text{CO}_3 + \text{K}_2\text{C}_2\text{O}_4 \rightleftharpoons \text{Ag}_2\text{C}_2\text{O}_4 + \text{K}_2\text{CO}_3$$
- At equilibrium the solution contains 0.0358 mole of  $\text{K}_2\text{CO}_3$ . Assuming the degree of dissociation of  $\text{K}_2\text{C}_2\text{O}_4$  and  $\text{K}_2\text{CO}_3$  to be equal, calculate the solubility product of  $\text{Ag}_2\text{CO}_3$ .

21. A 40.0 ml solution of weak base, BOH is titrated with 0.1N HCl solution. The pH of the solution is found to be 10.04 and 9.14 after adding 5.0 ml and 20.0 ml of the acid respectively. Find out the dissociation constant of the base. (1991 - 6 Marks)
22. The solubility product ( $K_{sp}$ ) of  $\text{Ca}(\text{OH})_2$  at 25°C is  $4.42 \times 10^{-5}$ . A 500 ml. of saturated solution of  $\text{Ca}(\text{OH})_2$  is mixed with equal volume of 0.4 M NaOH. How much  $\text{Ca}(\text{OH})_2$  in milligrams is precipitated? (1992 - 4 Marks)
23. 0.15 mole of CO taken in a 2.5 l flask is maintained at 750 K along with a catalyst so that the following reaction can take place:
- $$\text{CO}(\text{g}) + 2\text{H}_2(\text{g}) \rightleftharpoons \text{CH}_3\text{OH}(\text{g})$$
- Hydrogen is introduced until the total pressure of the system is 8.5 atmosphere at equilibrium and 0.08 mole of methanol is formed. Calculate (i)  $K_p$  and  $K_c$  and (ii) the final pressure if the same amount of CO and  $\text{H}_2$  as before are used, but with no catalyst so that the reaction does not take place. (1993 - 5 Marks)
24. The pH of blood stream is maintained by a proper balance of  $\text{H}_2\text{CO}_3$  and  $\text{NaHCO}_3$  concentrations. What volume of 5M  $\text{NaHCO}_3$  solution should be mixed with a 10 ml sample of blood which is 2M in  $\text{H}_2\text{CO}_3$  in order to maintain a pH of 7.4?  $K_a$  for  $\text{H}_2\text{CO}_3$  in blood is  $7.8 \times 10^{-7}$ . (1993 - 2 Marks)
25. An aqueous solution of a metal bromide  $\text{MBr}_2$  (0.05M) is saturated with  $\text{H}_2\text{S}$ . What is the minimum pH at which MS will precipitate? (1993 - 3 Marks)
- $K_{sp}$  for MS =  $6.0 \times 10^{-21}$ ; concentration of saturated  $\text{H}_2\text{S}$  = 0.1 M
- $K_1 = 10^{-7}$  and  $K_2 = 1.3 \times 10^{-13}$ , for  $\text{H}_2\text{S}$ .
26. At temperature  $T$ , a compound  $\text{AB}_2$  (g) dissociates according to the reaction (1994 - 4 Marks)
- $$2\text{AB}_2(\text{g}) \rightleftharpoons 2\text{AB}(\text{g}) + \text{B}_2(\text{g})$$
- with a degree of dissociation  $x$  which is small compared with unity. Deduce the expression for  $x$  in terms of the equilibrium constant  $K_p$  and the total pressure,  $P$ .
27. For the reaction
- $$[\text{Ag}(\text{CN})_2]^- \rightleftharpoons \text{Ag}^+ + 2\text{CN}^-$$
- the equilibrium constant, at 25°C, is  $4.0 \times 10^{-19}$ . Calculate the silver ion concentration in a solution which was originally 0.10 molar in KCN and 0.03 molar in  $\text{AgNO}_3$ . (1994 - 3 Marks)
28. Calculate the pH of an aqueous solution of 1.0 M ammonium formate assuming complete dissociation. ( $pK_a$  of formic acid = 3.8 and  $pK_b$  of ammonia = 4.8.) (1995 - 2 Marks)
29. What is the pH of a 0.50 M aqueous NaCN solution?  $pK_b$  of  $\text{CN}^-$  is 4.70. (1996 - 2 Marks)
30. A sample of AgCl was treated with 5.00 mL of 1.5 M  $\text{Na}_2\text{CO}_3$  solution to give  $\text{Ag}_2\text{CO}_3$ . The remaining solution contained 0.0026 g of  $\text{Cl}^-$  per litre. Calculate the solubility product of AgCl ( $K_{sp}(\text{Ag}_2\text{CO}_3) = 8.2 \times 10^{-12}$ ). (1997 - 5 Marks)
31. An acid type indicator, HIn differs in colour from its conjugate base ( $\text{In}^-$ ). The human eye is sensitive to colour differences only when the ratio  $[\text{In}^-]/[\text{HIn}]$  is greater than 10 or smaller than 0.1. What should be the minimum change in the pH of the solution to observe a complete colour change ( $K_a = 1.0 \times 10^{-5}$ )? (1997 - 2 Marks)
32. Given:  $\text{Ag}(\text{NH}_3)_2^+ \rightleftharpoons \text{Ag}^+ + 2\text{NH}_3$ ,  $K_c = 6.2 \times 10^{-8}$  and  $K_{sp}$  of  $\text{AgCl} = 1.8 \times 10^{-10}$  at 298 K. If ammonia is added to a water solution containing excess of  $\text{AgCl}(\text{s})$  only, calculate the concentration of the complex in 1.0 M aqueous ammonia. (1998 - 5 Marks)
33. What will be the resultant pH when 200 mL of an aqueous solution of HCl (pH = 2.0) is mixed with 300 mL of an aqueous solution of NaOH (pH = 12.0)? (1998 - 2 Marks)
34. When 3.06 g of solid  $\text{NH}_4\text{HS}$  is introduced into a two litre evacuated flask at 27°C, 30% of the solid decomposes into gaseous ammonia and hydrogen sulphide. (i) Calculate  $K_c$  and  $K_p$  for the reaction at 27°C. (ii) What would happen to the equilibrium when more solid  $\text{NH}_4\text{HS}$  is introduced into the flask? (1999 - 7 Marks)
35. The solubility of  $\text{Pb}(\text{OH})_2$  in water is  $6.7 \times 10^{-6}$  M. Calculate the solubility of  $\text{Pb}(\text{OH})_2$  in a buffer solution of pH = 8. (1999 - 4 Marks)
36. The average concentration of  $\text{SO}_2$  in the atmosphere over a city on a certain day is 10 ppm, when the average temperature is 298 K. Given that the solubility of  $\text{SO}_2$  in water at 298 K is 1.3653 moles litre<sup>-1</sup> and the  $pK_a$  of  $\text{H}_2\text{SO}_3$  is 1.92, estimate the pH of rain on that day. (2000 - 5 Marks)
37. 500 mL of 0.2 M aqueous solution of acetic acid is mixed with 500 mL of 0.2 M HCl at 25°C.
- (i) Calculate the degree of dissociation of acetic acid in the resulting solution and pH of the solution.
- (ii) If 6 g of NaOH is added to the above solution, determine the final pH. [Assume there is no change in volume on mixing;  $K_a$  of acetic acid is  $1.75 \times 10^{-5}$  mol L<sup>-1</sup>]. (2002 - 5 Marks)
38. Match the following if the molecular weights of X, Y and Z are same. (2003 - 2 Marks)
- |   | Boiling Point | $K_b$ |
|---|---------------|-------|
| x | 100           | 0.63  |
| y | 27            | 0.53  |
| z | 253           | 0.98  |

## G

## Comprehension Based Questions

## PARAGRAPH 1

When 100 mL of 1.0 M HCl was mixed with 100 mL of 1.0 M NaOH in an insulated beaker at constant pressure, a temperature increase of 5.7°C was measured for the beaker and its contents (Expt. 1). Because the enthalpy of neutralization of a strong acid with a strong base is a constant ( $-57.0$  kJ mol<sup>-1</sup>), this experiment could be used to measure the calorimeter constant. In a second experiment (Expt. 2), 100 mL of 2.0 M acetic acid ( $K_a = 2.0 \times 10^{-5}$ ) was mixed with 100 mL of 1.0 M NaOH (under identical conditions to Expt. 1) where a temperature rise of 5.6°C was measured. (Consider heat capacity of all solutions as 4.2 J g<sup>-1</sup> K<sup>-1</sup> and density of all solutions as 1.0 g mL<sup>-1</sup>) (JEE Adv. 2015)

## Equilibrium

- Enthalpy of dissociation (in  $\text{kJ mol}^{-1}$ ) of acetic acid obtained from the Expt.2 is  
(a) 1.0 (b) 10.0 (c) 24.5 (d) 51.4
- The pH of the solution after Expt. 2 is  
(a) 2.8 (b) 4.7  
(c) 5.0 (d) 7.0

## PARAGRAPH 2

Thermal decomposition of gaseous  $X_2$  to gaseous X at 298 K takes place according to the following equation:

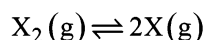

The standard reaction Gibbs energy,  $\Delta_r G^\circ$ , of this reaction is positive. At the start of the reaction, there is one mole of  $X_2$  and no X. As the reaction proceeds, the number of moles of X formed is given by  $\beta$ . Thus,  $\beta_{\text{equilibrium}}$  is the number of moles of X formed at equilibrium. The reaction is carried out at a constant total pressure of 2 bar. Consider the gases to behave ideally.

(Given  $R = 0.083 \text{ L bar K}^{-1} \text{ mol}^{-1}$ ) (JEE Adv. 2016)

- The equilibrium constant  $K_p$  for this reaction at 298 K, in terms of  $\beta_{\text{equilibrium}}$  is  
(a)  $\frac{8\beta_{\text{equilibrium}}^2}{2-\beta_{\text{equilibrium}}}$  (b)  $\frac{8\beta_{\text{equilibrium}}^2}{4-\beta_{\text{equilibrium}}}$   
(c)  $\frac{4\beta_{\text{equilibrium}}^2}{2-\beta_{\text{equilibrium}}}$  (d)  $\frac{4\beta_{\text{equilibrium}}^2}{4-\beta_{\text{equilibrium}}}$
- The INCORRECT statement among the following, for this reaction, is  
(a) Decrease in the total pressure will result in formation of more moles of gaseous X  
(b) At the start of the reaction, dissociation of gaseous  $X_2$  takes place spontaneously  
(c)  $\beta_{\text{equilibrium}} = 0.7$   
(d)  $K_c < 1$

## H Assertion &amp; Reason Type Questions

- Each question contains STATEMENT-1 (Assertion) and STATEMENT-2 (Reason). Each question has 5 choices (a), (b), (c) and (d) out of which ONLY ONE is correct. Mark your answer as  
(a) If both Statement -1 and Statement -2 are correct, and Statement -2 is the correct explanation of the Statement-2.

- If both Statement -1 and Statement -2 are correct, but Statement -2 is not the correct explanation of the Statement -1.  
(c) If Statement -1 is correct but Statement -2 is incorrect.  
(d) If Statement -1 is incorrect but Statement -2 is correct.
- Statement -1** The endothermic reactions are favoured at lower temperature and the exothermic reactions are favoured at higher temperature.

**Statement -2** When a system in equilibrium is disturbed by changing the temperature, it will tend to adjust itself so as to overcome the effect of change. (1991 - 2 Marks)

- Read the following statement and explanation and answer as per the options given below :  
**Statement -1**  $\text{HNO}_3$  is a stronger acid than  $\text{HNO}_2$   
**Statement -2** In  $\text{HNO}_3$  there are two nitrogen-to-oxygen bonds whereas in  $\text{HNO}_2$  there is only one. (1998 - 2 Marks)

- Statement -1** For every chemical reaction at equilibrium, standard Gibbs energy of reaction is zero.  
**Statement -2** At constant temperature and pressure, chemical reactions are spontaneous in the direction of decreasing Gibbs energy. (2008)

## I Integer Value Correct Type

- 0.1 M NaOH is titrated with 0.1 M HA till the end point;  $K_a$  for HA is  $5.6 \times 10^{-6}$  and degree of hydrolysis is less compared to 1. Calculate pH of the resulting solution at the end point. (2004 - 2 Marks)
- The dissociation constant of a substituted benzoic acid at  $25^\circ\text{C}$  is  $1.0 \times 10^{-4}$ . The pH of a 0.01 M solution of its sodium salt is (2009 - 2 Marks)
- Amongst the following, the total number of compounds whose aqueous solution turns red litmus paper blue is KCN,  $\text{K}_2\text{SO}_4$ ,  $(\text{NH}_4)_2\text{C}_2\text{O}_4$ , NaCl,  $\text{Zn}(\text{NO}_3)_2$ ,  $\text{FeCl}_3$ ,  $\text{K}_2\text{CO}_3$ ,  $\text{NH}_4\text{NO}_3$  and LiCN (2010)
- The total number of diprotic acids among the following is:  $\text{H}_3\text{PO}_4$ ,  $\text{H}_2\text{SO}_4$ ,  $\text{H}_3\text{PO}_3$ ,  $\text{H}_2\text{CO}_3$ ,  $\text{H}_2\text{S}_2\text{O}_7$ ,  $\text{H}_3\text{BO}_3$ ,  $\text{H}_3\text{PO}_2$ ,  $\text{H}_2\text{CrO}_4$  and  $\text{H}_2\text{SO}_3$ . (2010)
- In 1 L saturated solution of AgCl [ $K_{sp}(\text{AgCl}) = 1.6 \times 10^{-10}$ ], 0.1 mol of CuCl [ $K_{sp}(\text{CuCl}) = 1.0 \times 10^{-6}$ ] is added. The resultant concentration of  $\text{Ag}^+$  in the solution is  $1.6 \times 10^{-x}$ . The value of "x" is (2011)

## Section-B

## JEE Main / AIEEE

- 1 M NaCl and 1 M HCl are present in an aqueous solution. The solution is [2002]  
(a) not a buffer solution with  $\text{pH} < 7$   
(b) not a buffer solution with  $\text{pH} > 7$   
(c) a buffer solution with  $\text{pH} < 7$   
(d) a buffer solution with  $\text{pH} > 7$ .
- Species acting as both Bronsted acid and base is  
(a)  $(\text{HSO}_4)^{-1}$  (b)  $\text{Na}_2\text{CO}_3$  [2002]  
(c)  $\text{NH}_3$  (d)  $\text{OH}^{-1}$ .
- Let the solubility of an aqueous solution of  $\text{Mg}(\text{OH})_2$  be x then its  $K_{sp}$  is [2002]  
(a)  $4x^3$  (b)  $108x^5$   
(c)  $27x^4$  (d)  $9x$ .
- Change in volume of the system does not alter which of the following equilibria? [2002]

- (a)  $\text{N}_2(\text{g}) + \text{O}_2(\text{g}) \rightleftharpoons 2\text{NO}(\text{g})$   
 (b)  $\text{PCl}_5(\text{g}) \rightleftharpoons \text{PCl}_3(\text{g}) + \text{Cl}_2(\text{g})$   
 (c)  $\text{N}_2(\text{g}) + 3\text{H}_2(\text{g}) \rightleftharpoons 2\text{NH}_3(\text{g})$   
 (d)  $\text{SO}_2\text{Cl}_2(\text{g}) \rightleftharpoons \text{SO}_2(\text{g}) + \text{Cl}_2(\text{g})$
5. For the reaction  $\text{CO}(\text{g}) + (1/2)\text{O}_2(\text{g}) = \text{CO}_2(\text{g})$ ,  $K_p/K_c$  is  
 (a)  $RT$  (b)  $(RT)^{-1}$  [2002]  
 (c)  $(RT)^{-1/2}$  (d)  $(RT)^{1/2}$
6. Which one of the following statements is not true? [2003]  
 (a)  $\text{pH} + \text{pOH} = 14$  for all aqueous solutions  
 (b) The pH of  $1 \times 10^{-8}$  M HCl is 8  
 (c) 96,500 coulombs of electricity when passed through a  $\text{CuSO}_4$  solution deposits 1 gram equivalent of copper at the cathode  
 (d) The conjugate base of  $\text{H}_2\text{PO}_4^-$  is  $\text{HPO}_4^{2-}$
7. The solubility in water of a sparingly soluble salt  $\text{AB}_2$  is  $1.0 \times 10^{-5}$  mol  $\text{L}^{-1}$ . Its solubility product number will be  
 (a)  $4 \times 10^{-10}$  (b)  $1 \times 10^{-15}$  [2003]  
 (c)  $1 \times 10^{-10}$  (d)  $4 \times 10^{-15}$
8. For the reaction equilibrium [2003]  
 $\text{N}_2\text{O}_4(\text{g}) \rightleftharpoons 2\text{NO}_2(\text{g})$   
 the concentrations of  $\text{N}_2\text{O}_4$  and  $\text{NO}_2$  at equilibrium are  $4.8 \times 10^{-2}$  and  $1.2 \times 10^{-2}$  mol  $\text{L}^{-1}$  respectively. The value of  $K_c$  for the reaction is  
 (a)  $3 \times 10^{-1}$  mol  $\text{L}^{-1}$  (b)  $3 \times 10^{-3}$  mol  $\text{L}^{-1}$   
 (c)  $3 \times 10^3$  mol  $\text{L}^{-1}$  (d)  $3.3 \times 10^2$  mol  $\text{L}^{-1}$
9. Consider the reaction equilibrium [2003]  
 $2\text{SO}_2(\text{g}) + \text{O}_2(\text{g}) \rightleftharpoons 2\text{SO}_3(\text{g}); \Delta H^\circ = -198$  kJ  
 On the basis of Le Chatelier's principle, the condition favourable for the forward reaction is  
 (a) increasing temperature as well as pressure  
 (b) lowering the temperature and increasing the pressure  
 (c) any value of temperature and pressure  
 (d) lowering of temperature as well as pressure
10. When rain is accompanied by a thunderstorm, the collected rain water will have a pH value [2003]  
 (a) slightly higher than that when the thunderstorm is not there  
 (b) uninfluenced by occurrence of thunderstorm  
 (c) which depends on the amount of dust in air  
 (d) slightly lower than that of rain water without thunderstorm.
11. The conjugate base of  $\text{H}_2\text{PO}_4^-$  is [2004]  
 (a)  $\text{H}_3\text{PO}_4$  (b)  $\text{P}_2\text{O}_5$   
 (c)  $\text{PO}_4^{3-}$  (d)  $\text{HPO}_4^{2-}$
12. What is the equilibrium expression for the reaction [2004]  
 $\text{P}_4(\text{s}) + 5\text{O}_2(\text{g}) \rightleftharpoons \text{P}_4\text{O}_{10}(\text{s})$   
 (a)  $K_c = [\text{O}_2]^5$   
 (b)  $K_c = [\text{P}_4\text{O}_{10}]/5[\text{P}_4][\text{O}_2]$   
 (c)  $K_c = [\text{P}_4\text{O}_{10}]/[\text{P}_4][\text{O}_2]^5$   
 (d)  $K_c = 1/[\text{O}_2]^5$
13. For the reaction,  $\text{CO}(\text{g}) + \text{Cl}_2(\text{g}) \rightleftharpoons \text{COCl}_2(\text{g})$  the  $K_p/K_c$  is equal to [2004]  
 (a)  $\sqrt{RT}$  (b)  $RT$   
 (c)  $1/RT$  (d) 1.0
14. The equilibrium constant for the reaction  $\text{N}_2(\text{g}) + \text{O}_2(\text{g}) \rightleftharpoons 2\text{NO}_2(\text{g})$  at temperature T is  $4 \times 10^{-4}$ . The value of  $K_c$  for the reaction  $\text{NO}_2(\text{g}) \rightleftharpoons \frac{1}{2}\text{N}_2(\text{g}) + \frac{1}{2}\text{O}_2(\text{g})$  at the same temperature is  
 (a)  $4 \times 10^{-4}$  (b) 50 [2004]  
 (c)  $2.5 \times 10^2$  (d) 0.02
15. The molar solubility (in mol  $\text{L}^{-1}$ ) of a sparingly soluble salt  $\text{MX}_4$  is 's'. The corresponding solubility product is  $K_{sp}$ . 's' is given in term of  $K_{sp}$  by the relation : [2004]  
 (a)  $s = (256 K_{sp})^{1/5}$  (b)  $s = (128 K_{sp})^{1/4}$   
 (c)  $s = (K_{sp}/128)^{1/4}$  (d)  $s = (K_{sp}/256)^{1/5}$
16. If  $\alpha$  is the degree of dissociation of  $\text{Na}_2\text{SO}_4$ , the Vant Hoff's factor (i) used for calculating the molecular mass is [2005]  
 (a)  $1 - 2\alpha$  (b)  $1 + 2\alpha$   
 (c)  $1 - \alpha$  (d)  $1 + \alpha$
17. The solubility product of a salt having general formula  $\text{MX}_2$ , in water is :  $4 \times 10^{-12}$ . The concentration of  $\text{M}^{2+}$  ions in the aqueous solution of the salt is [2005]  
 (a)  $4.0 \times 10^{-10}$  M (b)  $1.6 \times 10^{-4}$  M  
 (c)  $1.0 \times 10^{-4}$  M (d)  $2.0 \times 10^{-6}$  M
18. The exothermic formation of  $\text{ClF}_3$  is represented by the equation :  
 $\text{Cl}_2(\text{g}) + 3\text{F}_2(\text{g}) \rightleftharpoons 2\text{ClF}_3(\text{g}); \Delta H = -329$  kJ  
 Which of the following will increase the quantity of  $\text{ClF}_3$  in an equilibrium mixture of  $\text{Cl}_2$ ,  $\text{F}_2$  and  $\text{ClF}_3$ ? [2005]  
 (a) Adding  $\text{F}_2$   
 (b) Increasing the volume of the container  
 (c) Removing  $\text{Cl}_2$   
 (d) Increasing the temperature
19. For the reaction :  $2\text{NO}_{2(\text{g})} \rightleftharpoons 2\text{NO}_{(\text{g})} + \text{O}_{2(\text{g})}$ ,  
 ( $K_c = 1.8 \times 10^{-6}$  at  $184^\circ\text{C}$ ) ( $R = 0.0831$  kJ/(mol. K))



When  $K_p$  and  $K_c$  are compared at  $184^\circ\text{C}$ , it is found that

- [2005]
- (a) Whether  $K_p$  is greater than, less than or equal to  $K_c$  depends upon the total gas pressure
- (b)  $K_p = K_c$
- (c)  $K_p$  is less than  $K_c$
- (d)  $K_p$  is greater than  $K_c$
20. Hydrogen ion concentration in mol/L in a solution of  $\text{pH} = 5.4$  will be : [2005]
- (a)  $3.98 \times 10^{-6}$  (b)  $3.68 \times 10^{-6}$
- (c)  $3.88 \times 10^6$  (d)  $3.98 \times 10^8$
21. What is the conjugate base of  $\text{OH}^-$ ? [2005]
- (a)  $\text{O}^{2-}$  (b)  $\text{O}^-$
- (c)  $\text{H}_2\text{O}$  (d)  $\text{O}_2$
22. An amount of solid  $\text{NH}_4\text{HS}$  is placed in a flask already containing ammonia gas at a certain temperature and 0.50 atm pressure. Ammonium hydrogen sulphide decomposes to yield  $\text{NH}_3$  and  $\text{H}_2\text{S}$  gases in the flask. When the decomposition reaction reaches equilibrium, the total pressure in the flask rises to 0.84 atm? The equilibrium constant for  $\text{NH}_4\text{HS}$  decomposition at this temperature is
- (a) 0.11 (b) 0.17 [2005]
- (c) 0.18 (d) 0.30
23. Phosphorus pentachloride dissociates as follows, in a closed reaction vessel [2006]
- $$\text{PCl}_5(\text{g}) \rightleftharpoons \text{PCl}_3(\text{g}) + \text{Cl}_2(\text{g})$$
- If total pressure at equilibrium of the reaction mixture is  $P$  and degree of dissociation of  $\text{PCl}_5$  is  $x$ , the partial pressure of  $\text{PCl}_3$  will be
- (a)  $\left(\frac{x}{x-1}\right)P$  (b)  $\left(\frac{x}{1-x}\right)P$
- (c)  $\left(\frac{x}{x+1}\right)P$  (d)  $\left(\frac{2x}{1-x}\right)P$
24. The equilibrium constant for the reaction
- $$\text{SO}_3(\text{g}) \rightleftharpoons \text{SO}_2(\text{g}) + \frac{1}{2}\text{O}_2(\text{g})$$
- is  $K_c = 4.9 \times 10^{-2}$ . The value of  $K_c$  for the reaction
- $$2\text{SO}_2(\text{g}) + \text{O}_2(\text{g}) \rightleftharpoons 2\text{SO}_3(\text{g})$$
- will be [2006]
- (a)  $9.8 \times 10^{-2}$  (b)  $4.9 \times 10^{-2}$
- (c) 416 (d)  $2.40 \times 10^{-3}$
25. Given the data at  $25^\circ\text{C}$
- $$\text{Ag} + \text{I}^- \longrightarrow \text{AgI} + \text{e}^- \quad E^\circ = 0.152 \text{ V}$$
- $$\text{Ag} \longrightarrow \text{Ag}^+ + \text{e}^- \quad E^\circ = -0.800 \text{ V}$$
- What is the value of  $\log K_{\text{sp}}$  for  $\text{AgI}$ ? ( $2.303 RT/F = 0.059 \text{ V}$ )
- (a)  $-37.83$  (b)  $-16.13$  [2006]
- (c)  $-8.12$  (d)  $+8.612$
26. The first and second dissociation constants of an acid  $\text{H}_2\text{A}$  are  $1.0 \times 10^{-5}$  and  $5.0 \times 10^{-10}$  respectively. The overall dissociation constant of the acid will be [2007]
- (a)  $0.2 \times 10^5$  (b)  $5.0 \times 10^{-5}$
- (c)  $5.0 \times 10^{15}$  (d)  $5.0 \times 10^{-15}$
27. The  $\text{pK}_a$  of a weak acid (HA) is 4.5. The  $\text{pOH}$  of an aqueous buffer solution of HA in which 50% of the acid is ionized is
- (a) 7.0 (b) 4.5 [2007]
- (c) 2.5 (d) 9.5
28. In a saturated solution of the sparingly soluble strong electrolyte  $\text{AgIO}_3$  (molecular mass = 283) the equilibrium which sets in is  $\text{AgIO}_3(\text{s}) \rightleftharpoons \text{Ag}^+(\text{aq}) + \text{IO}_3^-(\text{aq})$ . If the solubility product constant  $K_{\text{sp}}$  of  $\text{AgIO}_3$  at a given temperature is  $1.0 \times 10^{-8}$ , what is the mass of  $\text{AgIO}_3$  contained in 100 ml of its saturated solution? [2007]
- (a)  $1.0 \times 10^{-4} \text{ g}$  (b)  $28.3 \times 10^{-2} \text{ g}$
- (c)  $2.83 \times 10^{-3} \text{ g}$  (d)  $1.0 \times 10^{-7} \text{ g}$
29. The equilibrium constants  $K_{p1}$  and  $K_{p2}$  for the reactions  $\text{X} \rightleftharpoons 2\text{Y}$  and  $\text{Z} \rightleftharpoons \text{P} + \text{Q}$ , respectively are in the ratio of 1 : 9. If the degree of dissociation of X and Z be equal then the ratio of total pressures at these equilibria is [2008]
- (a) 1:36 (b) 1:1
- (c) 1:3 (d) 1:9
30. For the following three reactions a, b and c, equilibrium constants are given: [2008]
- (i)  $\text{CO}(\text{g}) + \text{H}_2\text{O}(\text{g}) \rightleftharpoons \text{CO}_2(\text{g}) + \text{H}_2(\text{g}); K_1$
- (ii)  $\text{CH}_4(\text{g}) + \text{H}_2\text{O}(\text{g}) \rightleftharpoons \text{CO}(\text{g}) + 3\text{H}_2(\text{g}); K_2$
- (iii)  $\text{CH}_4(\text{g}) + 2\text{H}_2\text{O}(\text{g}) \rightleftharpoons \text{CO}_2(\text{g}) + 4\text{H}_2(\text{g}); K_3$
- (a)  $K_1\sqrt{K_2} = K_3$  (b)  $K_2K_3 = K_1$
- (c)  $K_3 = K_1K_2$  (d)  $K_3 \cdot K_2^3 = K_1^2$
31. Four species are listed below: [2008]
- i.  $\text{HCO}_3^-$  ii.  $\text{H}_3\text{O}^+$
- iii.  $\text{HSO}_4^-$  iv.  $\text{HSO}_3\text{F}$
- Which one of the following is the correct sequence of their acid strength?
- (a)  $\text{iv} < \text{ii} < \text{iii} < \text{i}$  (b)  $\text{ii} < \text{iii} < \text{i} < \text{iv}$
- (c)  $\text{i} < \text{iii} < \text{ii} < \text{iv}$  (d)  $\text{iii} < \text{i} < \text{iv} < \text{ii}$
32. The  $\text{pK}_a$  of a weak acid, HA, is 4.80. The  $\text{pK}_b$  of a weak base, BOH, is 4.78. The pH of an aqueous solution of the corresponding salt, BA, will be [2008]
- (a) 9.58 (b) 4.79
- (c) 7.01 (d) 9.22

33. Solid  $\text{Ba}(\text{NO}_3)_2$  is gradually dissolved in a  $1.0 \times 10^{-4}$  M  $\text{Na}_2\text{CO}_3$  solution. At what concentration of  $\text{Ba}^{2+}$  will a precipitate begin to form? ( $K_{\text{sp}}$  for  $\text{BaCO}_3 = 5.1 \times 10^{-9}$ ) [2009]
- (a)  $5.1 \times 10^{-5}$  M (b)  $8.1 \times 10^{-8}$  M  
(c)  $8.1 \times 10^{-7}$  M (d)  $4.1 \times 10^{-5}$  M
34. Three reactions involving  $\text{H}_2\text{PO}_4^-$  are given below :
- (i)  $\text{H}_3\text{PO}_4 + \text{H}_2\text{O} \rightarrow \text{H}_3\text{O}^+ + \text{H}_2\text{PO}_4^-$   
(ii)  $\text{H}_2\text{PO}_4^- + \text{H}_2\text{O} \rightarrow \text{HPO}_4^{2-} + \text{H}_3\text{O}^+$   
(iii)  $\text{H}_2\text{PO}_4^- + \text{OH}^- \rightarrow \text{H}_3\text{PO}_4 + \text{O}^{2-}$
- In which of the above does  $\text{H}_2\text{PO}_4^-$  act as an acid ? [2010]
- (a) (ii) only (b) (i) and (ii)  
(c) (iii) only (d) (i) only
35. In aqueous solution the ionization constants for carbonic acid are  $K_1 = 4.2 \times 10^{-7}$  and  $K_2 = 4.8 \times 10^{-11}$ . Select the correct statement for a saturated 0.034 M solution of the carbonic acid. [2010]
- (a) The concentration of  $\text{CO}_3^{2-}$  is 0.034 M.  
(b) The concentration of  $\text{CO}_3^{2-}$  is greater than that of  $\text{HCO}_3^-$ .  
(c) The concentrations of  $\text{H}^+$  and  $\text{HCO}_3^-$  are approximately equal.  
(d) The concentration of  $\text{H}^+$  is double that of  $\text{CO}_3^{2-}$ .
36. Solubility product of silver bromide is  $5.0 \times 10^{-13}$ . The quantity of potassium bromide (molar mass taken as 120 g  $\text{mol}^{-1}$ ) to be added to 1 litre of 0.05 M solution of silver nitrate to start the precipitation of AgBr is [2010]
- (a)  $1.2 \times 10^{-10}$  g (b)  $1.2 \times 10^{-9}$  g  
(c)  $6.2 \times 10^{-5}$  g (d)  $5.0 \times 10^{-8}$  g
37. At  $25^\circ\text{C}$ , the solubility product of  $\text{Mg}(\text{OH})_2$  is  $1.0 \times 10^{-11}$ . At which pH, will  $\text{Mg}^{2+}$  ions start precipitating in the form of  $\text{Mg}(\text{OH})_2$  from a solution of 0.001 M  $\text{Mg}^{2+}$  ions? [2010]
- (a) 9 (b) 10  
(c) 11 (d) 8
38. A vessel at 1000 K contains  $\text{CO}_2$  with a pressure of 0.5 atm. Some of the  $\text{CO}_2$  is converted into CO on the addition of graphite. If the total pressure at equilibrium is 0.8 atm, the value of K is : [2011]
- (a) 1.8 atm (b) 3 atm  
(c) 0.3 atm (d) 0.18 atm
39. The equilibrium constant ( $K_c$ ) for the reaction  $\text{N}_2(\text{g}) + \text{O}_2(\text{g}) \rightarrow 2\text{NO}(\text{g})$  at temperature T is  $4 \times 10^{-4}$ . The value of  $K_c$  for the reaction [2012]
- $\text{NO}(\text{g}) \rightarrow \frac{1}{2}\text{N}_2(\text{g}) + \frac{1}{2}\text{O}_2(\text{g})$  at the same temperature is:
- (a) 0.02 (b)  $2.5 \times 10^2$   
(c)  $4 \times 10^{-4}$  (d) 50.0
40. The pH of a 0.1 molar solution of the acid HQ is 3. The value of the ionization constant,  $K_a$  of the acid is : [2012]
- (a)  $3 \times 10^{-1}$  (b)  $1 \times 10^{-3}$   
(c)  $1 \times 10^{-5}$  (d)  $1 \times 10^{-7}$
41. How many litres of water must be added to 1 litre an aqueous solution of HCl with a pH of 1 to create an aqueous solution with pH of 2 ? [JEE M 2013]
- (a) 0.1 L (b) 0.9 L  
(c) 2.0 L (d) 9.0 L
42. For the reaction  $\text{SO}_2(\text{g}) + \frac{1}{2}\text{O}_2(\text{g}) \rightleftharpoons \text{SO}_3(\text{g})$ , if  $K_P = K_C (RT)^x$  where the symbols have usual meaning then the value of x is (assuming ideality): [JEE M 2014]
- (a) -1 (b)  $-\frac{1}{2}$   
(c)  $\frac{1}{2}$  (d) 1
43. The standard Gibbs energy change at 300 K for the reaction  $2\text{A} \rightleftharpoons \text{B} + \text{C}$  is 2494.2 J. At a given time, the composition of the reaction mixture is  $[\text{A}] = \frac{1}{2}$ ,  $[\text{B}] = 2$  and  $[\text{C}] = \frac{1}{2}$ . The reaction proceeds in the :  $[\text{R} = 8.314 \text{ J/K/mol}, e = 2.718]$  [JEE M 2015]
- (a) forward direction because  $Q < K_c$   
(b) reverse direction because  $Q < K_c$   
(c) forward direction because  $Q > K_c$   
(d) reverse direction because  $Q > K_c$
44. The following reaction is performed at 298 K.
- $$2\text{NO}(\text{g}) + \text{O}_2(\text{g}) \rightleftharpoons 2\text{NO}_2(\text{g})$$
- The standard free energy of formation of  $\text{NO}(\text{g})$  is 86.6 kJ/mol at 298 K. What is the standard free energy of formation of  $\text{NO}_2(\text{g})$  at 298 K? ( $K_p = 1.6 \times 10^{12}$ ) [JEE M 2015]
- (a)  $86600 - \frac{\ln(1.6 \times 10^{12})}{\text{R}(298)}$   
(b)  $0.5[2 \times 86,600 - \text{R}(298)\ln(1.6 \times 10^{12})]$   
(c)  $\text{R}(298)\ln(1.6 \times 10^{12}) - 86600$   
(d)  $86600 + \text{R}(298)\ln(1.6 \times 10^{12})$
45. The equilibrium constant at 298 K for a reaction  $\text{A} + \text{B} \rightleftharpoons \text{C} + \text{D}$  is 100. If the initial concentration of all the four species were 1 M each, then equilibrium concentration of D (in mol  $\text{L}^{-1}$ ) will be : [JEE M 2016]
- (a) 1.818 (b) 1.182  
(c) 0.182 (d) 0.818

## CHAPTER

## 8

## The s-Block Elements

## Section-A JEE Advanced/ IIT-JEE

## A Fill in the Blanks

- Anhydrous  $\text{MgCl}_2$  is obtained by heating hydrated salt with ..... (1980)
- The absorption of hydrogen by palladium is commonly known as ..... (1983 - 1 Mark)
- Sodium dissolved in liquid ammonia conducts electricity because ..... (1985 - 1 Mark)
- The electrolysis of molten sodium hydride liberates ..... gas at the ..... (1989 - 1 Mark)
- $\text{Ca}^{2+}$  has a smaller ionic radius than  $\text{K}^+$  because it has ..... (1993 - 1 Mark)
- Heavy water is (1983 - 1 Mark)
  - $\text{H}_2^{18}\text{O}$
  - water obtained by repeated distillation
  - $\text{D}_2\text{O}$
  - water at  $4^\circ\text{C}$
- The hydration energy of  $\text{Mg}^{++}$  is larger than that of:
  - $\text{Al}^{3+}$
  - $\text{Na}^+$  (1984 - 1 Mark)
  - $\text{Be}^{++}$
  - $\text{Mg}^{3+}$
- The oxide that gives hydrogen peroxide on treatment with a dilute acid is: (1985 - 1 Mark)
  - $\text{PbO}_2$
  - $\text{Na}_2\text{O}_2$
  - $\text{MnO}_2$
  - $\text{TiO}_2$
- Molecular formula of Glauber's salt is: (1985 - 1 Mark)
  - $\text{MgSO}_4 \cdot 7\text{H}_2\text{O}$
  - $\text{CuSO}_4 \cdot 5\text{H}_2\text{O}$
  - $\text{FeSO}_4 \cdot 7\text{H}_2\text{O}$
  - $\text{Na}_2\text{SO}_4 \cdot 10\text{H}_2\text{O}$

## B True / False

- $\text{MgCl}_2 \cdot 6\text{H}_2\text{O}$  on heating give anhydrous  $\text{MgCl}_2$ . (1982 - 1 Mark)
- The softness of group I-A metals increases down the group with increasing atomic number. (1986 - 1 Mark)
- Sodium when burnt in excess of oxygen gives sodium oxide. (1987 - 1 Mark)
- Hydrogen gas will not reduce: (1985 - 1 Mark)
  - heated cupric oxide
  - heated ferric oxide
  - heated stannic oxide
  - heated aluminium oxide
- The pair of compounds which cannot exist together in solution is: (1986 - 1 Mark)
  - $\text{NaHCO}_3$  and  $\text{NaOH}$
  - $\text{Na}_2\text{CO}_3$  and  $\text{NaHCO}_3$
  - $\text{Na}_2\text{CO}_3$  and  $\text{NaOH}$
  - $\text{NaHCO}_3$  and  $\text{NaCl}$

## C MCQs with One Correct Answer

- A substance absorbs  $\text{CO}_2$  and violently reacts with water. The substance is (1978)
  - $\text{CaCO}_3$
  - $\text{CaO}$
  - $\text{H}_2\text{SO}_4$
  - $\text{ZnO}$
- $\text{HCl}$  is added to following oxides. Which one would give  $\text{H}_2\text{O}_2$ ? (1980)
  - $\text{MnO}_2$
  - $\text{PbO}_2$
  - $\text{BaO}_2 \cdot 8\text{H}_2\text{O}$
  - $\text{NO}_2$
- Calcium is obtained by (1980)
  - electrolysis of molten  $\text{CaCl}_2$ .
  - electrolysis of solution of  $\text{CaCl}_2$  in water.
  - Reduction of  $\text{CaCl}_2$  with carbon.
  - roasting of limestone.
- A solution of sodium metal in liquid ammonia is strongly reducing due to the presence of (1981 - 1 Mark)
  - sodium atoms
  - sodium hydride
  - sodium amide
  - solvated electrons
- The following compounds have been arranged in order of their increasing thermal stabilities. Identify the correct order. (1996 - 1 Mark)
 

$\text{K}_2\text{CO}_3$  (I)  $\text{MgCO}_3$  (II)  $\text{CaCO}_3$  (III)  $\text{BeCO}_3$  (IV)

  - $\text{I} < \text{II} < \text{III} < \text{IV}$
  - $\text{IV} < \text{II} < \text{III} < \text{I}$
  - $\text{IV} < \text{II} < \text{I} < \text{III}$
  - $\text{II} < \text{IV} < \text{III} < \text{I}$
- The set representing the correct order of first ionization potential is (2001S)
  - $\text{K} > \text{Na} > \text{Li}$
  - $\text{Be} > \text{Mg} > \text{Ca}$
  - $\text{B} > \text{C} > \text{N}$
  - $\text{Ge} > \text{Si} > \text{C}$

15. A sodium salt on treatment with  $\text{MgCl}_2$  gives white precipitate only on heating. The anion of the sodium salt is  
 (a)  $\text{HCO}_3^-$  (b)  $\text{CO}_3^{2-}$  (2004S)  
 (c)  $\text{NO}_3^-$  (d)  $\text{SO}_4^{2-}$
16. Hydrogen peroxide in its reaction with  $\text{KIO}_4$  and  $\text{NH}_2\text{OH}$  respectively, is acting as a (JEE Adv. 2014)  
 (a) Reducing agent, oxidising agent  
 (b) Reducing agent, reducing agent  
 (c) Oxidising agent, oxidising agent  
 (d) Oxidising agent, reducing agent

### D MCQs with One or More Than One Correct

- When zeolite, which is hydrated sodium aluminium silicate, is treated with hard water the sodium ions are exchanged with (1990 - 1 Mark)  
 (a)  $\text{H}^+$  ions (b)  $\text{Ca}^{++}$  ions  
 (c)  $\text{SO}_4^{--}$  ions (d)  $\text{Mg}^{++}$  ions  
 (e)  $\text{OH}^-$  ions
- The species that do not contain peroxide ions are (1992 - 1 Mark)  
 (a)  $\text{PbO}_2$  (b)  $\text{H}_2\text{O}_2$   
 (c)  $\text{SrO}_2$  (d)  $\text{BaO}_2$
- Highly pure dilute solution of sodium in liquid ammonia (1998 - 2 Marks)  
 (a) shows blue colour  
 (b) exhibits electrical conductivity  
 (c) produces sodium amide  
 (d) produces hydrogen gas.
- The species present in solution when  $\text{CO}_2$  is dissolved in water are (2006 - 5M, -1)  
 (a)  $\text{CO}_2, \text{H}_2\text{CO}_3, \text{HCO}_3^-, \text{CO}_3^{2-}$   
 (b)  $\text{H}_2\text{CO}_3, \text{CO}_3^{2-}$   
 (c)  $\text{CO}_3^{2-}, \text{HCO}_3^-$   
 (d)  $\text{CO}_2, \text{H}_2\text{CO}_3$
- $\text{MgSO}_4$  on reaction with  $\text{NH}_4\text{OH}$  and  $\text{Na}_2\text{HPO}_4$  forms a white crystalline precipitate. What is its formula? (2006 - 5M, -1)  
 (a)  $\text{Mg}(\text{NH}_4)\text{PO}_4$  (b)  $\text{Mg}_3(\text{PO}_4)_2$   
 (c)  $\text{MgCl}_2 \cdot \text{MgSO}_4$  (d)  $\text{MgSO}_4$
- The compound(s) formed upon combustion of sodium metal in excess air is (are) (2009 - 5M, -1)  
 (a)  $\text{Na}_2\text{O}_2$  (b)  $\text{Na}_2\text{O}$   
 (c)  $\text{NaO}_2$  (d)  $\text{NaOH}$
- The reagent(s) used for softening the temporary hardness of water is (are) (2010)  
 (a)  $\text{Ca}_3(\text{PO}_4)_2$  (b)  $\text{Ca}(\text{OH})_2$   
 (c)  $\text{Na}_2\text{CO}_3$  (d)  $\text{NaOCl}$
- Hydrogen peroxide is a better oxidising agent than water. (1986 - 1 Mark)
- Magnesium oxide is used for the lining of steel making furnace. (1987 - 1 Mark)
- Why is sodium chloride added during electrolysis of fused anhydrous magnesium chloride? (1987 - 1 Mark)
- Hydrogen peroxide acts as an oxidising as well as a reducing agent. (1992 - 1 Mark)
- The crystalline salts of alkaline earth metals contain more water of crystallisation than the corresponding alkali metal salts. (1997 - 2 Marks)
- $\text{BeCl}_2$  can be easily hydrolysed. (1999 - 2 Marks)
- How will you prepare bleaching powder from slaked lime (1982 - 1 Mark)
- Write down the balanced equations for the reactions when:  
 (i) Calcum phosphate is heated with a mixture of sand and carbon; (1985 - 1 Mark)  
 (ii) An alkaline solution of potassium ferricyanide is reacted with hydrogen peroxide. (1982 - 1 Mark)  
 (iii) Carbon dioxide is passed through a concentrated aqueous solution of sodium chloride saturated with ammonia. (1988 - 1 Mark)  
 (iv) Potassium ferricyanide reacts with hydrogen peroxide in basic solution. (1989 - 1 Mark)  
 (v) Carbon dioxide is passed through a suspension of lime stone in water. (1991 - 1 Mark)
- Give briefly the isolation of magnesium from sea water by the Dow process. Give equations for the steps involved. (1993 - 3 Marks)
- Complete and balance the following reactions :  
 $\text{Ca}_5(\text{PO}_4)_3\text{F} + \text{H}_2\text{SO}_4 + \text{H}_2\text{O}$   
 $\xrightarrow{\text{Heat}} \dots\dots\dots + 5\text{CaSO}_4 \cdot 2\text{H}_2\text{O} + \dots\dots\dots$  (1994 - 1 Mark)
- A 5.0  $\text{cm}^3$  solution of  $\text{H}_2\text{O}_2$  liberates 0.508 g of iodine from an acidified KI solution. Calculate the strength of  $\text{H}_2\text{O}_2$  solution in terms of volume strength at STP. (1995 - 2 Marks)
- Explain the difference in the nature of bonding in  $\text{LiF}$  and  $\text{LiI}$ . (1996 - 2 Marks)
- To a 25ml  $\text{H}_2\text{O}_2$  solution, excess of acidified solution of potassium iodide was added. The iodine liberated required 20 ml of 0.3 N sodium thiosulphate solution. Calculate the volume strength of  $\text{H}_2\text{O}_2$  solution. (1997 - 5 Marks)
- Give reactions for the oxidation of hydrogen peroxide with potassium permanganate in acidic medium. (1997 - 1 Mark)

### E Subjective Problems

- Give reasons for the following :  
 (i) Sodium carbonate is made by Solvay process but the same process is not extended to the manufacture of potassium carbonate. (1981 - 1 Mark)
- Element A burns in nitrogen to give an ionic compound B. Compound B reacts with water to give C and D. A solution of C becomes 'milky' on bubbling carbon dioxide. Identify A, B, C and D. (1997 - 3 Marks)

11. Arrange the following sulphates of alkaline earth metals in order of decreasing thermal stability :  $\text{BeSO}_4$ ,  $\text{MgSO}_4$ ,  $\text{CaSO}_4$ ,  $\text{SrSO}_4$  (1997 - 1 Mark)
12. Work out the following using chemical equation:  
Chlorination of calcium hydroxide produces bleaching powder. (1998 - 2 Marks)
13. Hydrogen peroxide acts both as an oxidising and as a reducing agent in alkaline solution towards certain first row transition metal ions. Illustrate both these properties of  $\text{H}_2\text{O}_2$  using chemical equations. (1998 - 4 Marks)
2. This question contains STATEMENT-1 (Assertion) and STATEMENT-2 (Reason) and has 4 choices (a), (b), (c) and (d) out of which ONLY ONE is correct. (2007)

### H Assertion & Reason Type Questions

1. Read the following statement and explanation and answer as per the options given below :

**Statement :** The alkali metals can form ionic hydrides which contain the hydride ion  $\text{H}^-$ .

**Explanation :** The alkali metals have low electronegativity; their hydrides conduct electricity when fused and liberate hydrogen at the anode. (1994 - 2 Marks)

- (a) Both S and E are true and E is the correct explanation of S.
- (b) Both S and E are true but E is not the correct explanation of S.
- (c) S is true but E is false.
- (d) S is false but E is true
- STATEMENT-1 : Alkali metals dissolve in liquid ammonia to give blue solutions. because
- STATEMENT-2 : Alkali metals is liquid ammonia give solvated species of the type  $[\text{M}(\text{NH}_3)_n]^+$  (M = alkali metals).
- (a) Statement-1 is True, Statement-2 is True; Statement-2 is a correct explanation for Statement-1
- (b) Statement-1 is True, Statement-2 is True; Statement-2 is not correct explanation for Statement-1
- (c) Statement-1 is True, Statement-2 is False
- (d) Statement-1 is False, Statement-2 is True.

## Section-B JEE Main / AIEEE

1.  $\text{KO}_2$  (potassium super oxide) is used in oxygen cylinders in space and submarines because it [2002]  
(a) absorbs  $\text{CO}_2$  and increases  $\text{O}_2$  content  
(b) eliminates moisture  
(c) absorbs  $\text{CO}_2$   
(d) produces ozone.
2. The metallic sodium dissolves in liquid ammonia to form a deep blue coloured solution. The deep blue colour is due to formation of: [2002]  
(a) solvated electron,  $e(\text{NH}_3)_x^-$   
(b) solvated atomic sodium,  $\text{Na}(\text{NH}_3)_y$   
(c)  $(\text{Na}^+ + \text{Na}^-)$   
(d)  $\text{NaNH}_2 + \text{H}_2$
3. A metal M readily forms its sulphate  $\text{MSO}_4$  which is water-soluble. It forms its oxide MO which becomes inert on heating. It forms an insoluble hydroxide  $\text{M}(\text{OH})_2$  which is soluble in  $\text{NaOH}$  solution. Then M is [2002]  
(a) Mg (b) Ba  
(c) Ca (d) Be.
4. In curing cement plasters water is sprinkled from time to time. This helps in [2003]  
(a) developing interlocking needle-like crystals of hydrated silicates  
(b) hydrating sand and gravel mixed with cement  
(c) converting sand into silicic acid  
(d) keeping it cool
5. The substance **not** likely to contain  $\text{CaCO}_3$  is [2003]  
(a) calcined gypsum (b) sea shells  
(c) dolomite (d) a marble statue
6. The solubilities of carbonates decrease down the magnesium group due to a decrease in [2003]  
(a) hydration energies of cations  
(b) inter-ionic attraction  
(c) entropy of solution formation  
(d) lattice energies of solids
7. Which one of the following processes will produce hard water ? [2003]  
(a) Saturation of water with  $\text{MgCO}_3$   
(b) Saturation of water with  $\text{CaSO}_4$   
(c) Addition of  $\text{Na}_2\text{SO}_4$  to water  
(d) Saturation of water with  $\text{CaCO}_3$
8. One mole of magnesium nitride on the reaction with an excess of water gives : [2004]  
(a) two moles of ammonia  
(b) one mole of nitric acid  
(c) one mole of ammonia  
(d) two moles of nitric acid
9. Which of the following species is diamagnetic in nature? [2005]  
(a)  $\text{H}_2^-$  (b)  $\text{H}_2^+$   
(c)  $\text{H}_2$  (d)  $\text{He}_2^+$

10. Based on lattice energy and other considerations which one of the following alkali metal chlorides is expected to have the highest melting point ? [2005]  
 (a) RbCl (b) KCl  
 (c) NaCl (d) LiCl
11. Which of the following statements in relation to the hydrogen atom is correct ? [2005]  
 (a) 3s, 3p and 3d orbitals all have the same energy  
 (b) 3s and 3p orbitals are of lower energy than 3d orbital  
 (c) 3p orbital is lower in energy than 3d orbital  
 (d) 3s orbital is lower in energy than 3p orbital
12. The ionic mobility of alkali metal ions in aqueous solution is maximum for [2006]  
 (a)  $\text{Li}^+$  (b)  $\text{Na}^+$   
 (c)  $\text{K}^+$  (d)  $\text{Rb}^+$
13. In context with the industrial preparation of hydrogen from water gas ( $\text{CO} + \text{H}_2$ ), which of the following is the correct statement? [2008]  
 (a)  $\text{CO}$  and  $\text{H}_2$  are fractionally separated using differences in their densities  
 (b)  $\text{CO}$  is removed by absorption in aqueous  $\text{Cu}_2\text{Cl}_2$  solution  
 (c)  $\text{H}_2$  is removed through occlusion with  $\text{pd}$   
 (d)  $\text{CO}$  is oxidised to  $\text{CO}_2$  with steam in the presence of a catalyst followed by absorption of  $\text{CO}_2$  in alkali
14. Which of the following on thermal decomposition yields a basic as well as acidic oxide ? [2012]  
 (a)  $\text{NaNO}_3$  (b)  $\text{KClO}_3$   
 (c)  $\text{CaCO}_3$  (d)  $\text{NH}_4\text{NO}_3$
15. Very pure hydrogen (99.9) can be made by which of the following processes ? [2012]  
 (a) Reaction of methane with steam  
 (b) Mixing natural hydrocarbons of high molecular weight  
 (c) Electrolysis of water  
 (d) Reaction of salts like hydrides with water
16. In which of the following reactions  $\text{H}_2\text{O}_2$  acts as a reducing agent? [JEE M 2014]  
 (a)  $\text{H}_2\text{O}_2 + 2\text{H}^+ + 2\text{e}^- \rightarrow 2\text{H}_2\text{O}$   
 (b)  $\text{H}_2\text{O}_2 + 2\text{e}^- \rightarrow \text{O}_2 + 2\text{H}^+$   
 (c)  $\text{H}_2\text{O}_2 + 2\text{e}^- \rightarrow 2\text{OH}^-$   
 (d)  $\text{H}_2\text{O}_2 + 2\text{OH}^- - 2\text{e}^- \rightarrow \text{O}_2 + 2\text{H}_2\text{O}$
17. Which one of the following alkaline earth metal sulphates has its hydration enthalpy greater than its lattice enthalpy ? [JEE M 2015]  
 (a)  $\text{BaSO}_4$  (b)  $\text{SrSO}_4$   
 (c)  $\text{CaSO}_4$  (d)  $\text{BeSO}_4$
18. The molecular formula of a commercial resin used for exchanging ions in water softening is  $\text{C}_8\text{H}_7\text{SO}_3^- \text{Na}^+$  (Mol. wt. 206). What would be the maximum uptake of  $\text{Ca}^{2+}$  ions by the resin when expressed in mole per gram resin ? [JEE M 2015]  
 (a)  $\frac{2}{309}$  (b)  $\frac{1}{412}$   
 (c)  $\frac{1}{103}$  (d)  $\frac{1}{206}$
19. From the following statements regarding  $\text{H}_2\text{O}_2$ , choose the incorrect statement : [JEE M 2015]  
 (a) It has to be stored in plastic or wax lined glass bottles in dark  
 (b) It has to be kept away from dust  
 (c) It can act only as an oxidizing agent  
 (d) It decomposes on exposure to light
20. Which one of the following statements about water is FALSE? [JEE M 2016]  
 (a) There is extensive intramolecular hydrogen bonding in the condensed phase.  
 (b) Ice formed by heavy water sinks in normal water.  
 (c) Water is oxidized to oxygen during photosynthesis.  
 (d) Water can act both as an acid and as a base.
21. Which of the following atoms has the highest first ionization energy? [JEE M 2016]  
 (a) K (b) Sc  
 (c) Rb (d) Na
22. The main oxides formed on combustion of Li, Na and K in excess of air are, respectively: [JEE M 2016]  
 (a)  $\text{Li}_2\text{O}_2$ ,  $\text{Na}_2\text{O}_2$  and  $\text{KO}_2$  (b)  $\text{Li}_2\text{O}$ ,  $\text{Na}_2\text{O}_2$  and  $\text{KO}_2$   
 (c)  $\text{Li}_2\text{O}$ ,  $\text{Na}_2\text{O}$  and  $\text{KO}_2$  (d)  $\text{LiO}_2$ ,  $\text{Na}_2\text{O}_2$  and  $\text{K}_2\text{O}$

## CHAPTER

## 9

# Organic Chemistry — Some Basic Principles and Techniques

## Section-A

## JEE Advanced/ IIT-JEE

## A Fill in the Blanks

- Among the given cations, ..... is most stable. (1981)  
(*sec*-butyl carbonium ion; *tert*-butyl carbonium ion; *n*-butyl carbonium ion)
- The compound having both  $sp$  and  $sp^2$  hybridized carbon atoms is ..... (1981)  
(propene, propane, propadiene)
- ..... ring is most strained. (1981)  
(Cyclopropane, Cyclobutane, Cyclopentane)
- The terminal carbon atom in butane is ..... hybridised. (1985)
- A ..... diol has two hydroxyl groups on ..... carbon atoms. (1986)
- Isomers which are ..... mirror images are known as ..... (1988)  
(superimposable, non-superimposable, enantiomers, diastereomers, epimers)
- The valence atomic orbitals on carbon in silver acetylide is ..... hybridized. (1990)
- The kind of delocalization involving sigma bond orbitals is called ..... (1994)
- The IUPAC name of succinic acid is ..... (1994)
- Molecule in which the distance between the two adjacent carbon atoms is largest is (1981)  
(a) Ethane (b) Ethene  
(c) Ethyne (d) Benzene
- The compound which is not isomeric with diethyl ether is (1981)  
(a) *n*-propyl methyl ether (b) butan-1-ol  
(c) 2-methylpropan-2-ol (d) butanone
- Among the following, the compound that can be most readily sulphonated is (1982)  
(a) benzene (b) nitrobenzene  
(c) toluene (d) chlorobenzene
- The compound 1, 2-butadiene has (1983)  
(a) only  $sp$  hybridized carbon atoms  
(b) only  $sp^2$  hybridized carbon atoms  
(c) both  $sp$  and  $sp^2$  hybridized carbon atoms  
(d)  $sp$ ,  $sp^2$  and  $sp^3$  hybridized carbon atoms
- Which of the following compounds will exhibit *cis-trans* (geometrical) isomerism? (1983)  
(a) 2-butene (b) 2-butyne  
(c) 2-butanol (d) butanal
- The IUPAC name of the compound having the formula

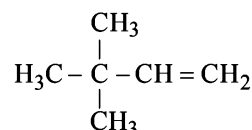

## B True / False

- Iodide is a better nucleophile than bromide. (1985 - 1/2 Mark)
- An electron donating substituent in benzene orients the incoming electrophilic group to the meta position. (1987)
- 2, 3, 4-Trichloropentane has three asymmetric carbon atoms. (1990)
- During  $S_N1$  reaction, the leaving group leaves the molecule before the incoming group is attached to the molecule. (1990)
- The IUPAC name of the compound having the formula is: (1984)  
(a) 3, 3, 3-Trimethyl-1-propene  
(b) 1, 1, 1-Trimethyl-2-propene  
(c) 3, 3-Dimethyl-1-butene  
(d) 2, 2-Dimethyl-3-butene
- An isomer of ethanol is: (1986)  
(a) methanol (b) diethyl ether  
(c) acetone (d) dimethyl ether

## C MCQs with One Correct Answer

- The bond order of individual carbon-carbon bonds in benzene is (1981)  
(a) one (b) two  
(c) between one and two (d) one and two, alternately
- Out of the following compounds, which will have a zero dipole moment? (1987)  
(a) 1, 1-dichloroethylene  
(b) *cis*-1, 2-dichloroethylene  
(c) *trans*-1, 2-dichloroethylene  
(d) None of these compounds

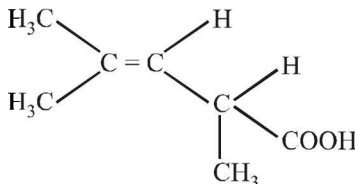
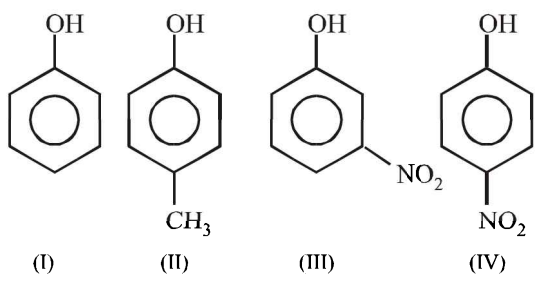
10. The bond between carbon atom (1) and carbon atom (2) in compound  $\text{N} \equiv \underset{1}{\text{C}} - \underset{2}{\text{CH}} = \text{CH}_2$  involves the hybrids as (1987)
- (a)  $sp^2$  and  $sp^2$  (b)  $sp^3$  and  $sp$   
(c)  $sp$  and  $sp^2$  (d)  $sp$  and  $sp$
11. The IUPAC name of the compound  $\text{CH}_2 = \text{CH} - \text{CH}(\text{CH}_3)_2$  is (1987)
- (a) 1, 1-dimethyl-2-propene (b) 3-methyl 1-butene  
(c) 2-vinylpropane (d) 1-isopropylethylene
12. The number of isomers of  $\text{C}_6\text{H}_{14}$  is (1987, 2007)
- (a) 4 (b) 5  
(c) 6 (d) 7
13. The  $\text{Cl}-\text{C}-\text{Cl}$  angle in 1,1,2,2-tetrachloroethene and tetrachloromethane respectively will be about (1988)
- (a)  $120^\circ$  and  $109.5^\circ$  (b)  $90^\circ$  and  $109.5^\circ$   
(c)  $109.5^\circ$  and  $90^\circ$  (d)  $109.5^\circ$  and  $120^\circ$
14. In  $\text{CH}_3\text{CH}_2\text{OH}$ , the bond that undergoes heterolytic cleavage most readily is (1988)
- (a)  $\text{C}-\text{C}$  (b)  $\text{C}-\text{O}$   
(c)  $\text{C}-\text{H}$  (d)  $\text{O}-\text{H}$
15. The compound which has one isopropyl group is : (1989)
- (a) 2, 2, 3, 3-tetramethylpentane  
(b) 2, 2-dimethylpentane  
(c) 2, 2, 3-trimethylpentane  
(d) 2-methylpentane
16. The  $\text{C}-\text{H}$  bond distance is the longest in : (1989)
- (a)  $\text{C}_2\text{H}_2$  (b)  $\text{C}_2\text{H}_4$   
(c)  $\text{C}_2\text{H}_6$  (d)  $\text{C}_2\text{H}_2\text{Br}_2$
17. The number of sigma and pi-bonds in 1-butene-3-yne are : (1989)
- (a) 5 sigma and 5 pi (b) 7 sigma and 3 pi  
(c) 8 sigma and 2 pi (d) 5 sigma and 4 pi
18. The compound which gives the most stable carbonium ion on dehydration is : (1989)
- (a)  $\text{CH}_3 - \underset{\text{CH}_3}{\text{CH}} - \text{CH}_2\text{OH}$  (b)  $\text{CH}_3 - \overset{\text{CH}_3}{\underset{\text{CH}_3}{\text{C}}} - \text{OH}$   
(c)  $\text{CH}_3 - \text{CH}_2 - \text{CH}_2 - \text{CH}_2\text{OH}$   
(d)  $\text{CH}_3 - \underset{\text{OH}}{\text{CH}} - \text{CH}_2 - \text{CH}_3$
19. The hybridization of carbon atoms in  $\text{C}-\text{C}$  single bond of  $\text{HC} \equiv \text{C} - \text{CH} = \text{CH}_2$  is (1991)
- (a)  $sp^3 - sp^3$  (b)  $sp^2 - sp^3$   
(c)  $sp - sp^2$  (d)  $sp^3 - sp$
20. The products of combustion of an aliphatic thiol ( $\text{RSH}$ ) at 298 K are (1992)
- (a)  $\text{CO}_2(\text{g})$ ,  $\text{H}_2\text{O}(\text{g})$  and  $\text{SO}_2(\text{g})$   
(b)  $\text{CO}_2(\text{g})$ ,  $\text{H}_2\text{O}(\text{l})$  and  $\text{SO}_2(\text{g})$   
(c)  $\text{CO}_2(\text{l})$ ,  $\text{H}_2\text{O}(\text{l})$  and  $\text{SO}_2(\text{g})$   
(d)  $\text{CO}_2(\text{g})$ ,  $\text{H}_2\text{O}(\text{l})$  and  $\text{SO}_2(\text{l})$
21. Isomers which can be interconverted through rotation around a single bond are (1992)
- (a) Conformers (b) Diastereomers  
(c) Enantiomers (d) Positional isomers
22. The structure  shows : (1995S)
- (a) geometrical isomerism  
(b) optical isomerism  
(c) geometrical & optical isomerism  
(d) tautomerism.
23. Allyl isocyanide has : (1995S)
- (a)  $9\sigma$  and  $4\pi$  bonds  
(b)  $8\sigma$  and  $5\pi$  bonds  
(c)  $9\sigma$ ,  $3\pi$  and 2 non-bonded electrons  
(d)  $8\sigma$ ,  $3\pi$  and 4 non-bonded electrons
24. Arrange in order of decreasing trend towards  $\text{S}_{\text{E}}$  reactions : (1995S)
- Chlorobenzene, benzene, anilinium chloride, toluene
- I II III IV
- (a)  $\text{II} > \text{I} > \text{III} > \text{IV}$  (b)  $\text{III} > \text{I} > \text{II} > \text{IV}$   
(c)  $\text{IV} > \text{II} > \text{I} > \text{III}$  (d)  $\text{I} > \text{II} > \text{III} > \text{IV}$
25. Most stable carbonium ion is : (1995S)
- (a)  $p\text{-NO}_2\text{-C}_6\text{H}_4\text{-CH}_2^+$   
(b)  $\text{C}_6\text{H}_5\text{CH}_2^+$   
(c)  $p\text{-Cl-C}_6\text{H}_4\text{-CH}_2^+$   
(d)  $p\text{-CH}_3\text{O-C}_6\text{H}_4\text{-CH}_2^+$
26. In the following compounds, (1996)
- 
- (I) (II) (III) (IV)
- The order of acidity is :
- (a)  $\text{III} > \text{IV} > \text{I} > \text{II}$  (b)  $\text{I} > \text{IV} > \text{III} > \text{II}$   
(c)  $\text{II} > \text{I} > \text{III} > \text{IV}$  (d)  $\text{IV} > \text{III} > \text{I} > \text{II}$
27. Arrange the following compounds in order of increasing dipole moment. (1996)
- Toluene (I) *m*-dichlorobenzene (II)  
*o*-dichlorobenzene (III) *p*-dichlorobenzene (IV)
- (a)  $\text{I} < \text{IV} < \text{II} < \text{III}$  (b)  $\text{IV} < \text{I} < \text{II} < \text{III}$   
(c)  $\text{IV} < \text{I} < \text{III} < \text{II}$  (d)  $\text{IV} < \text{II} < \text{I} < \text{III}$
28. How many optically active stereoisomers are possible for butane-2, 3-diol? (1997)
- (a) 1 (b) 2  
(c) 3 (d) 4



29. In the compound  $\text{CH}_2 = \text{CH}-\text{CH}_2-\text{CH}_2-\text{C} \equiv \text{CH}$ , the  $\text{C}_2-\text{C}_3$  bond is of the type, (1999)  
 (a)  $sp-sp^2$  (b)  $sp^3-sp^3$   
 (c)  $sp-sp^3$  (d)  $sp^2-sp^3$
30. The optically active tartaric acid is named as D-(+)-tartaric acid because it has a positive (1999)  
 (a) optical rotation and is derived from D-glucose  
 (b) pH in organic solvent  
 (c) optical rotation and is derived from D-(+)-glyceraldehyde  
 (d) optical rotation only when substituted by deuterium
31. Which of the following compounds will exhibit geometrical isomerism? (2000S)  
 (a) 1-Phenyl-2-butene (b) 3-Phenyl-1-butene  
 (c) 2-Phenyl-1-butene (d) 1,1-Diphenyl-1-propene
32. Which of the following has the highest nucleophilicity?  
 (a)  $\text{F}^-$  (b)  $\text{OH}^-$  (2000S)  
 (c)  $\text{CH}_3^-$  (d)  $\text{NH}_2^-$
33. The order of reactivities of the following alkyl halides for a  $\text{S}_\text{N}2$  reaction is (2000S)  
 (a)  $\text{RF} > \text{RCl} > \text{RBr} > \text{RI}$  (b)  $\text{RF} > \text{RBr} > \text{RCl} > \text{RI}$   
 (c)  $\text{RCl} > \text{RBr} > \text{RF} > \text{RI}$  (d)  $\text{RI} > \text{RBr} > \text{RCl} > \text{RF}$
34. Which of the following has the most acidic hydrogen? (2000S)  
 (a) 3-Hexanone (b) 2,4-Hexanedione  
 (c) 2,5-Hexanedione (d) 2,3-Hexanedione
35. The number of isomers for the compound with molecular formula  $\text{C}_2\text{BrClFI}$  is (2001S)  
 (a) 3 (b) 4  
 (c) 5 (d) 6
36. An  $\text{S}_\text{N}2$  reaction at an asymmetric carbon of a compound always gives (2001S)  
 (a) an enantiomer of the substrate  
 (b) a product with opposite optical rotation  
 (c) a mixture of diastereomers  
 (d) a single stereoisomer
37. Which of the following compounds exhibits stereoisomerism? (2002S)  
 (a) 2-methylbutene-1 (b) 3-methylbutyne-1  
 (c) 3-methylbutanoic acid (d) 2-methylbutanoic acid
38. Which of the following acids has the smallest dissociation constant? (2002S)  
 (a)  $\text{CH}_3\text{CHF}\text{COOH}$  (b)  $\text{FCH}_2\text{CH}_2\text{COOH}$   
 (c)  $\text{BrCH}_2\text{CH}_2\text{COOH}$  (d)  $\text{CH}_3\text{CHBr}\text{COOH}$
39. Identify the correct order of boiling points of the following compounds; (2002S)  
 $\text{CH}_3\text{CH}_2\text{CH}_2\text{CH}_2\text{OH}$ ,  $\text{CH}_3\text{CH}_2\text{CH}_2\text{CHO}$ ,  $\text{CH}_3\text{CH}_2\text{CH}_2\text{COOH}$   
 1 2 3  
 (a)  $1 > 2 > 3$  (b)  $3 > 1 > 2$   
 (c)  $1 > 3 > 2$  (d)  $3 > 2 > 1$
40. Identify the correct order of reactivity in electrophilic substitution reactions of the following compounds (2002S)

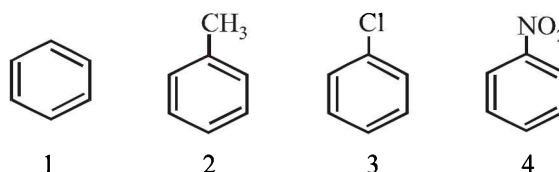

- (a)  $1 > 2 > 3 > 4$  (b)  $4 > 3 > 2 > 1$   
 (c)  $2 > 1 > 3 > 4$  (d)  $2 > 3 > 1 > 4$
41. Which of the following hydrocarbons has the lowest dipole moment? (2002S)

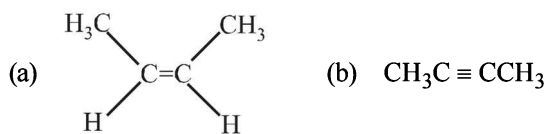

- (c)  $\text{CH}_3\text{CH}_2\text{C} \equiv \text{CH}$  (d)  $\text{CH}_2 = \text{CH} - \text{C} \equiv \text{CH}$
42. Which of the following represents the given mode of hybridisation  $sp^2-sp^2-sp-sp$  from left to right? (2003S)

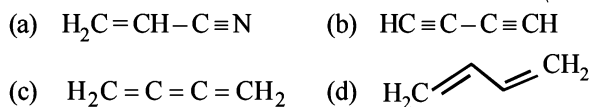

43. Among the following, the molecule with the highest dipole moment is: (2003S)

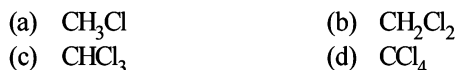

44. In the given conformation, if  $\text{C}_2$  is rotated about  $\text{C}_2 - \text{C}_3$  bond anticlockwise by an angle of  $120^\circ$  then the conformation obtained is (2004S)

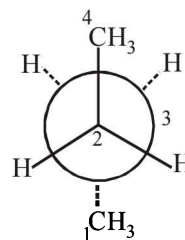

- (a) fully eclipsed conformation  
 (b) partially eclipsed conformation  
 (c) gauche conformation  
 (d) staggered conformation
45. Which of the following resonating structures of 1-methoxy-1,3-butadiene is least stable? (2005S)

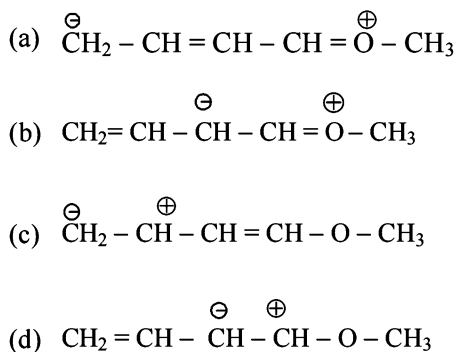

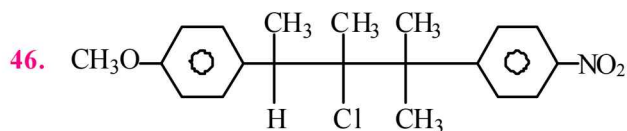

compound on hydrolysis in aqueous acetone will give (2005S)

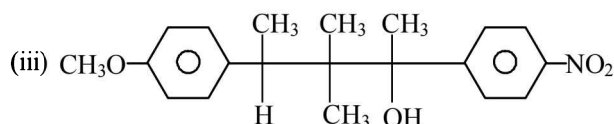
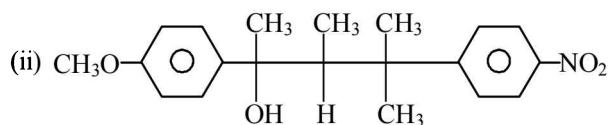
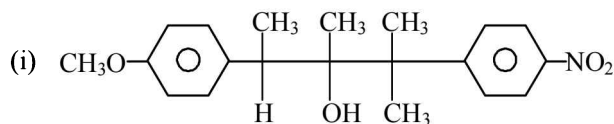

- (a) Mixture of (i) and (ii)      (b) Mixture of (i) and (iii)  
(c) Only (iii)                      (d) Only (i)

47. The IUPAC name of  $C_6H_5COCl$  is (2006 - 3M, -1)

- (a) Benzene chloro ketone  
(b) Benzoyl chloride  
(c) Chloro phenyl ketone  
(d) Benzene carbonyl chloride

48. In the following reaction,

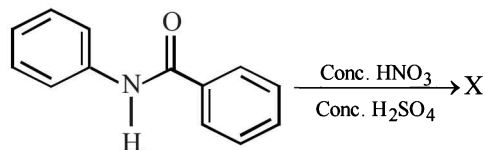

the structure of the major product 'X' is (2007)

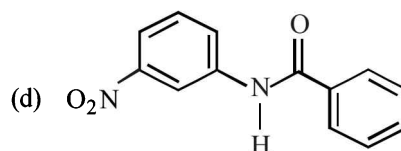
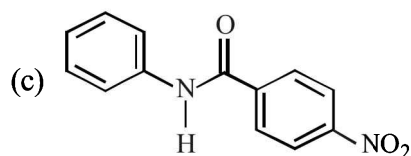
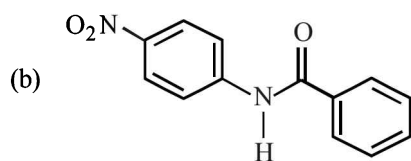
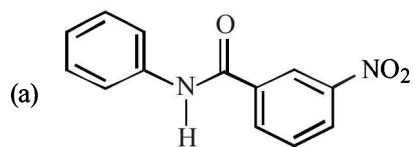

49. Among the following, the least stable resonance structure is (2007)

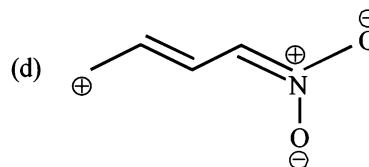
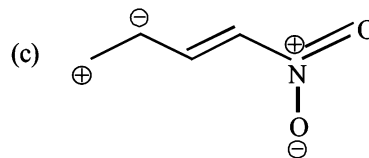
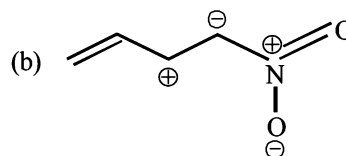
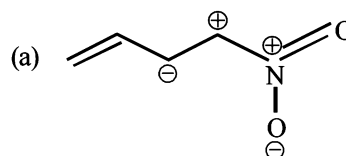

50. The number of stereoisomers obtained by bromination of *trans*-2-butene is (2007)

- (a) 1                                      (b) 2  
(c) 3                                      (d) 4

51. Hyperconjugation involves overlap of the following orbitals (2008)

- (a)  $\sigma$ - $\sigma$                               (b)  $\sigma$ - $\pi$   
(c) p-p                                    (d)  $\pi$ - $\pi$

52. The correct stability order for the following species is (2008)

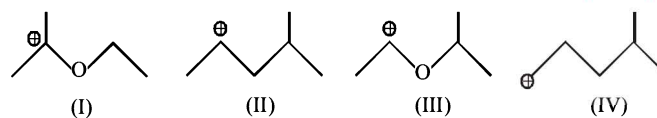

- (a) (II) > (IV) > (I) > (III)      (b) (I) > (II) > (III) > (IV)  
(c) (II) > (I) > (IV) > (III)      (d) (I) > (III) > (II) > (IV)

53. The IUPAC name of the following compound is (2009)

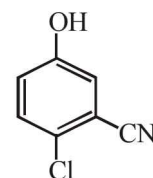

- (a) 4-Bromo-3-cyanophenol  
(b) 2-Bromo-5-hydroxybenzonitrile  
(c) 2-Cyano-4-hydroxybromobenzene  
(d) 6-Bromo-3-hydroxybenzonitrile

54. In the following carbocation, H/CH<sub>3</sub> that is most likely to migrate to the positively charged carbon is (2009)

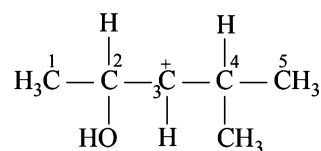

- (a) CH<sub>3</sub> at C-4 (b) Hat C-4  
(c) CH<sub>3</sub> at C-2 (d) Hat C-2
55. Among the following compounds, the most acidic is (2011)

- (a) *p*-nitrophenol (b) *p*-hydroxybenzoic acid  
(c) *o*-hydroxybenzoic acid (d) *p*-toluic acid

56. KI in acetone, undergoes S<sub>N</sub>2 reaction with each of P, Q, R and S. The rates of the reaction vary as (JEE Adv. 2013)

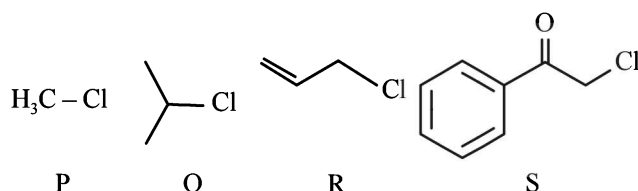

- (a) P > Q > R > S (b) S > P > R > Q  
(c) P > R > Q > S (d) R > P > S > Q

### D MCQs with One or More Than One Correct

1. Resonance structures of a molecule should have : (1984)  
(a) identical arrangement of atoms  
(b) nearly the same energy content  
(c) the same number of paired electrons  
(d) identical bonding
2. Phenol is less acidic than : (1986)  
(a) acetic acid (b) *p*-methoxyphenol  
(c) *p*-nitrophenol (d) ethanol
3. Dipole moment is shown by : (1986)  
(a) 1, 4-dichlorobenzene  
(b) *cis*-1, 2-dichloroethane  
(c) *trans*-1, 2-dichloroethene  
(d) *trans*-1, 2-dichloro-2-pentene
4. Only two isomeric monochloro derivatives are possible for: (1986)  
(a) *n*-butane (b) 2, 4-dimethylpentane  
(c) benzene (d) 2-methylpropane
5. Which of the following have asymmetric carbon atom? (1989)

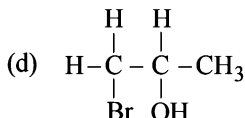
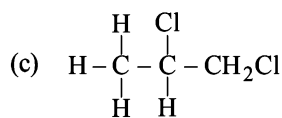
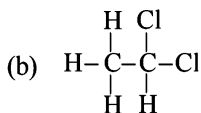
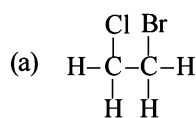

6. What is the decreasing order of strength of the bases OH<sup>-</sup>, NH<sub>2</sub><sup>-</sup>, HC≡C<sup>-</sup> and CH<sub>3</sub>CH<sub>2</sub><sup>-</sup>? (1993)

- (a) CH<sub>3</sub>-CH<sub>2</sub><sup>-</sup> > NH<sub>2</sub><sup>-</sup> > H-C≡C<sup>-</sup> > OH<sup>-</sup>  
(b) H-C≡C<sup>-</sup> > CH<sub>3</sub>-CH<sub>2</sub><sup>-</sup> > NH<sub>2</sub><sup>-</sup> > OH<sup>-</sup>  
(c) OH<sup>-</sup> > NH<sub>2</sub><sup>-</sup> > H-C≡C<sup>-</sup> > CH<sub>3</sub>-CH<sub>2</sub><sup>-</sup>  
(d) NH<sub>2</sub><sup>-</sup> > H-C≡C<sup>-</sup> > OH<sup>-</sup> > CH<sub>3</sub>-CH<sub>2</sub><sup>-</sup>

7. Which of the following compounds will show geometrical isomerism? (1998)

- (a) 2-butene (b) propene  
(c) 1-phenylpropene (d) 2-methyl-2-butene

8. Among the following compounds, the strongest acid is (1998)

- (a) HC≡CH (b) C<sub>6</sub>H<sub>6</sub>  
(c) C<sub>2</sub>H<sub>6</sub> (d) CH<sub>3</sub>OH

9. Tautomerism is exhibited by (1998)

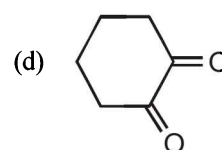
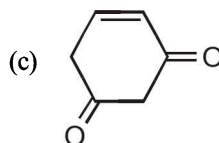
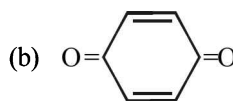
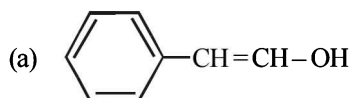

10. An aromatic molecule will (1999)

- (a) have 4n π electrons (b) have (4n + 2) π electrons  
(c) be planar (d) be cyclic

11. The correct statement(s) concerning the structures E, F and G is (are)– (2008)

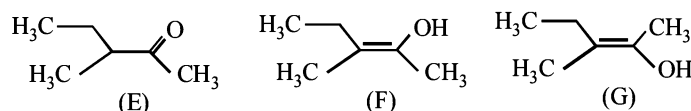

- (a) E, F, and G are resonance structures  
(b) E, F and E, G are tautomers  
(c) F and G are geometrical isomers  
(d) F and G are diastereomers

12. The correct statement(s) about the compound given below is (are) (2008)

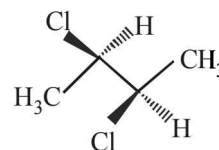

- (a) The compound is optically active  
(b) The compound possesses centre of symmetry  
(c) The compound possesses plane of symmetry  
(d) The compound possesses axis of symmetry

13. The correct statement(s) about the compound (2009)  
 $\text{H}_3\text{C}(\text{HO})\text{HC}=\text{CH}-\text{CH}(\text{OH})\text{CH}_3$  (X) is(are)  
 (a) The total number of stereoisomers possible for X is 6  
 (b) The total number of diastereomers possible for X is 3  
 (c) If the stereochemistry about the double bond in X is *trans*, the number of enantiomers possible for X is 4  
 (d) If the stereochemistry about the double bond in X is *cis*, the number of enantiomers possible for X is 2
14. In the Newman projection for 2,2-dimethylbutane

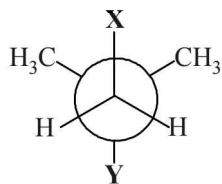

X and Y can respectively be (2010)

- (a) H and H (b) H and  $\text{C}_2\text{H}_5$   
 (c)  $\text{C}_2\text{H}_5$  and H (d)  $\text{CH}_3$  and  $\text{CH}_3$
15. Amongst the given options, the compound(s) in which all the atoms are in one plane in all the possible conformations (if any), is (are) (2011)

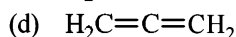
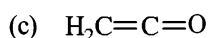
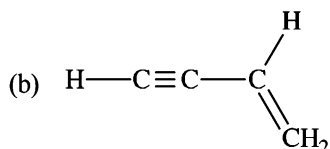
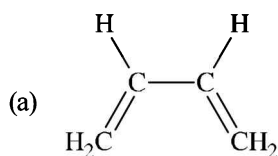

16. Which of the following molecules, in pure form, is (are) unstable at room temperature? (2012)

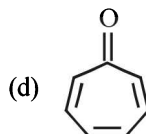
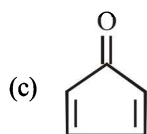
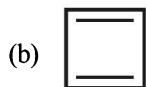
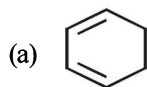

17. Which of the given statement(s) about N, O, P and Q with respect to M is (are) correct? (2012)

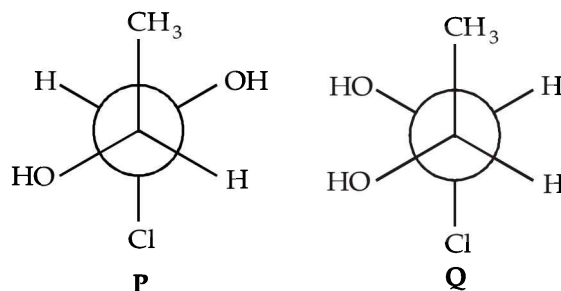
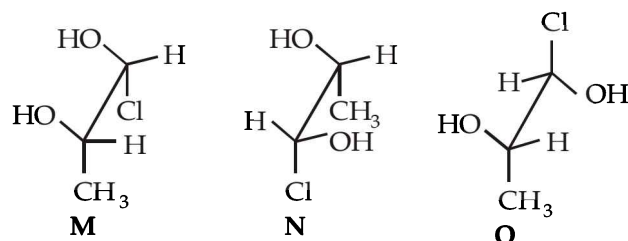

- (a) M and N are non-mirror image stereoisomers  
 (b) M and O are identical  
 (c) M and P are enantiomers  
 (d) M and Q are identical
18. The hyperconjugative stabilities of tert-butyl cation and 2-butene, respectively, are due to (JEE Adv. 2013)
- (a)  $\sigma \rightarrow p$  (empty) and  $\sigma \rightarrow \pi^*$  electron delocalisations  
 (b)  $\sigma \rightarrow \sigma^*$  and  $\sigma \rightarrow \pi$  electron delocalisations  
 (c)  $\sigma \rightarrow p$  (filled) and  $\sigma \rightarrow \pi$  electron delocalisations  
 (d)  $p$  (filled)  $\rightarrow \sigma^*$  and  $\sigma \rightarrow \pi^*$  electron delocalisations

## E Subjective Problems

1. Arrange the following in :
- (i) Increasing reactivity towards HCN (1985)  
 $\text{CH}_3\text{CHO}$ ,  $\text{CH}_3\text{COCH}_3$ ,  $\text{HCHO}$ ,  $\text{C}_2\text{H}_5\text{COCH}_3$
- (ii) *n*-butane, *n*-butanol, *n*-butyl chloride, isobutane in increasing order of boiling point. (1988)
- (iii) benzene, toluene, methoxybenzene, chlorobenzene in increasing order of reactivity towards sulphonation with fuming sulphuric acid. (1988)
- (iv) Increasing order of acid strength : (1991)  
 $\text{ClCH}_2\text{COOH}$  (I),  $\text{CH}_3\text{CH}_2\text{COOH}$  (II),  
 $\text{ClCH}_2\text{CH}_2\text{COOH}$  (III),  $(\text{CH}_3)_2\text{CHCOOH}$  (IV),  
 $\text{CH}_3\text{COOH}$  (V)
- (v) Increasing reactivity in nucleophilic substitution reactions (1992)  
 $\text{CH}_3\text{F}$ ,  $\text{CH}_3\text{I}$ ,  $\text{CH}_3\text{Br}$ ,  $\text{CH}_3\text{Cl}$
2. (i) Write the IUPAC name of: (1986)  
 $\text{CH}_3\text{CH}_2\text{CH}=\text{CHCOOH}$
- (ii) Give the IUPAC name of the following compound : (1990)

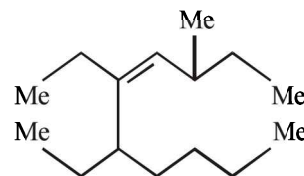

(Me = Methyl)

- (iii) Write the IUPAC name for the following :

- (1991) 3. For nitromethane molecule, write structure(s).  
 (i) showing significant resonance stabilisation. (1986)  
 (ii) indicating tautomerism. (1986)
4. Give reasons for the following :  
 (i) Carbon oxygen bond lengths in formic acid are 1.23 Å and 1.36 Å and both the carbon oxygen bonds in sodium formate have the same value i.e. 1.27 Å. (1988)  
 (ii) Phenyl group is known to exert negative inductive effect. But each phenyl ring in biphenyl ( $C_6H_5-C_6H_5$ ) is more reactive than benzene towards electrophilic substitution. (1992)  
 (iii) Aryl halides are less reactive than alkyl halides towards nucleophilic reagents (1994)  
 (iv)  $CH_2=CH^-$  is more basic than  $HC \equiv C^-$ .  
 (v) Normally, benzene gives electrophilic substitution reaction rather than electrophilic addition reaction although it has double bonds.
5. Write the structural formula of 4-chloro-2-pentene. (1988)
6. Write tautomeric forms for phenol. (1992)
7. Write down the structures of the stereoisomers formed when *cis*-2-butene is reacted with bromine. (1995)
8. Discuss the hybridisation of carbon atoms in allene ( $C_3H_4$ ) and show the  $\pi$ -orbital overlaps. (1999)
9. Identify the pairs of enantiomers and diastereomers from the following compounds I, II and III (2000)

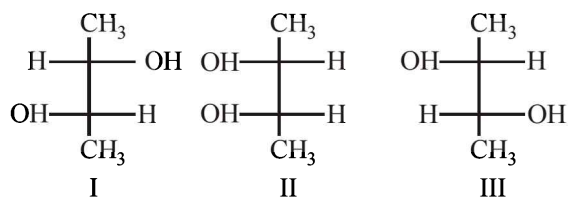

10. Which one is more soluble in diethyl ether - anhydrous  $AlCl_3$  or hydrous  $AlCl_3$ ? Explain in terms of bonding. (2003)

- (1991) 11. Match the  $K_a$  values

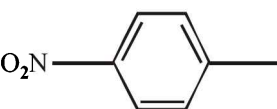
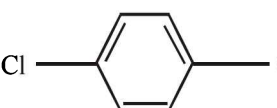
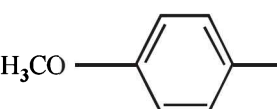
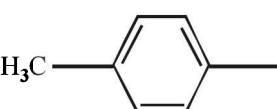
	$K_a$
(a) Benzoic acid	$6.4 \times 10^{-5}$
(b) 	$30.6 \times 10^{-5}$
(c) 	$10.2 \times 10^{-5}$
(d) 	$3.3 \times 10^{-5}$
(e) 	$4.2 \times 10^{-5}$

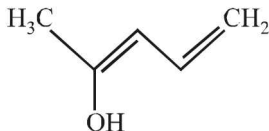
12.  (2003)

Write resonance structure of the given compound.

13. Which of the following is more acidic and why? (2004)

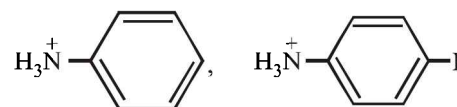

14. (i)  $\mu_{obs} = \sum_i \mu_i x_i$ , where  $\mu_i$  is the dipole moment of a stable conformer of the molecule,  $Z-CH_2-CH_2-Z$  and  $x_i$  is the mole fraction of the stable conformer.  
 Given :  $\mu_{obs} = 1.0 \text{ D}$  and  $x_{(Anti)} = 0.82$   
 Draw all the stable conformers of  $Z-CH_2-CH_2-Z$  and calculate the value of  $\mu_{(Gauche)}$ .
- (ii) Draw the stable conformer of  $Y-CHD-CHD-Y$  (meso form), when  $Y = CH_3$  (rotation about  $C_2-C_3$ ) and  $Y = OH$  (rotation about  $C_1-C_2$ ) in Newmann projection. (2005)

## F Match the Following

Each question contains statements given in two columns, which have to be matched. The statements in Column-I are labelled A, B, C and D, while the statements in Column-II are labelled p, q, r, s and t. Any given statement in Column-I can have correct matching with ONE OR MORE statement(s) in Column-II. The appropriate bubbles corresponding to the answers to these questions have to be darkened as illustrated in the following example :

If the correct matches are A-p, s and t; B-q and r; C-p and q; and D-s then the correct darkening of bubbles will look like the given.

	p	q	r	s	t
A	<input checked="" type="checkbox"/>	<input type="checkbox"/>	<input type="checkbox"/>	<input checked="" type="checkbox"/>	<input checked="" type="checkbox"/>
B	<input type="checkbox"/>	<input checked="" type="checkbox"/>	<input checked="" type="checkbox"/>	<input type="checkbox"/>	<input type="checkbox"/>
C	<input checked="" type="checkbox"/>	<input checked="" type="checkbox"/>	<input type="checkbox"/>	<input type="checkbox"/>	<input type="checkbox"/>
D	<input type="checkbox"/>	<input type="checkbox"/>	<input type="checkbox"/>	<input checked="" type="checkbox"/>	<input type="checkbox"/>

1. Given below are certain matching type questions, where two columns (each having 4 items) are given. Immediately after the columns the matching grid is given, where each item of Column I has to be matched with the items of Column II, by encircling the correct match(es). Note that an item of **Column I** can match with more than one item of **Column II**. All the items of **Column II** must be matched. Match the following : (2006 - 6M)

### Column I

- (A)  $C_6H_5CH_2CD_2Br$  on reaction with  $C_2H_5O^-$  gives  $C_6H_5-CH=CD_2$   
 (B)  $PhCHBrCH_3$  and  $PhCHBrCD_3$ , both react with the same rate  
 (C)  $C_6H_5CH_2CH_2Br$  on treatment with  $C_2H_5O^-$  and  $C_2H_5OD$  gives  $C_6H_5CD=CH_2$   
 (D)  $C_6H_5CH_2CH_2Br$  reacts faster than  $C_6H_5CD_2CH_2Br$  on reaction with  $C_2H_5O^-$  in ethanol

### Column II

- (p) E1 reaction  
 (q) E2 reaction  
 (r) E1cB reaction  
 (s) First order reaction

2. Match the compounds/ions in **Column I** with their properties/reactions in **Column II**. Indicate your answer by darkening the appropriate bubbles of the  $4 \times 4$  matrix given in the ORS. (2007)

### Column I

- (A)  $C_6H_5CHO$   
 (B)  $CH_3C \equiv CH$   
 (C)  $CN^-$   
 (D)  $I^-$

### Column II

- (p) gives precipitate with 2, 4-dinitrophenylhydrazine  
 (q) gives precipitate with  $AgNO_3$   
 (r) is a nucleophile  
 (s) is involved in cyanohydrin formation

3. Match each of the compounds given in **Column-I** with the reaction(s), that they can undergo, given in **Column-II**. (2009)

### Column-I

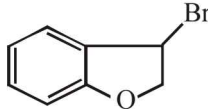
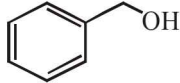
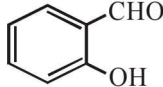
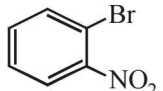
- (A) 
- (B) 
- (C) 
- (D) 

### Column-II

- (p) Nucleophilic substitution  
 (q) Elimination  
 (r) Nucleophilic addition  
 (s) Esterification with acetic anhydride  
 (t) Dehydrogenation

4. Match the reactions in **Column I** with appropriate types of steps/reactive intermediate involved in these reactions as given in **Column II**. (2011)

Column I	Column II
<p>(A) </p>	(p) Nucleophilic substitution
<p>(B) </p>	(q) Electrophilic substitution
<p>(C) </p>	(r) Dehydration
<p>(D) </p>	(s) Nucleophilic addition
	(t) Carbanion

### H Assertion & Reason Type Questions

Read the following Statement-1 (Assertion) and Statement -2 (Reason) and answer as per the options given below :

- (a) If both Statement -1 and Statement -2 are correct, and Statement -2 is the correct explanation of the Statement-2.  
 (b) If both Statement -1 and Statement -2 are correct, but Statement -2 is not the correct explanation of the Statement-1.  
 (c) If Statement -1 is correct but Statement -2 is incorrect.  
 (d) If Statement -1 is incorrect but Statement -2 is correct.

1. **Statement -1:** Aryl halides undergo nucleophilic substitution with ease.  
**Statement -2:** The carbon-halogen bond in aryl halides has partial double bond character. (1991)
2. **Statement -1:** Phenol is more reactive than benzene towards electrophilic substitution reactions.  
**Statement -2:** In the case of phenol, the intermediate carbocation is more resonance stabilized. (2000S)
3. **Statement -1:** Molecules that are not superimposable on their mirror images are chiral.  
**Statement -2:** All chiral molecules have chiral centres. (2007)

### I Integer Value Correct Type

1. The total number of cyclic structural as well as stereo isomers possible for a compound with the molecular formula  $C_5H_{10}$  is (2009)
2. The total number of cyclic isomers possible for a hydrocarbon with the molecular formula  $C_4H_6$  is 5. (2010)
3. The maximum number of isomers (including stereoisomers) that are possible on monochlorination of the following compound is (2011)

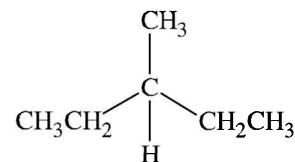

4. The total number of contributing structures showing hyperconjugation (involving C-H bonds) for the following carbocation is (2011)

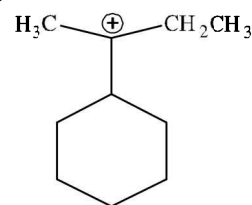

5. The total number(s) of **stable** conformers with **non-zero** dipole moment for the following compound is (are) (JEE Adv. 2014)

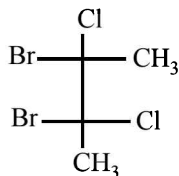

6. The total number of stereoisomers that can exist for M is (JEE Adv. 2015)

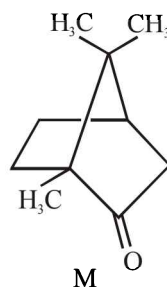

## Section-B

## JEE Main / AIEEE

1. Arrangement of  $(\text{CH}_3)_3\text{C}-$ ,  $(\text{CH}_3)_2\text{CH}-$ ,  $\text{CH}_3-\text{CH}_2-$  when attached to benzyl or an unsaturated group in increasing order of inductive effect is [2002]
- $(\text{CH}_3)_3\text{C}- < (\text{CH}_3)_2\text{CH}- < \text{CH}_3-\text{CH}_2-$
  - $\text{CH}_3-\text{CH}_2- < (\text{CH}_3)_2\text{CH}- < (\text{CH}_3)_3\text{C}-$
  - $(\text{CH}_3)_2\text{CH}- < (\text{CH}_3)_3\text{C}- < \text{CH}_3-\text{CH}_2-$
  - $(\text{CH}_3)_3\text{C}- < \text{CH}_3-\text{CH}_2- < (\text{CH}_3)_2\text{CH}-$
2. A similarity between optical and geometrical isomerism is that [2002]
- each forms equal number of isomers for a given compound
  - if in a compound one is present then so is the other
  - both are included in stereoisomerism
  - they have no similarity.
3. Which of the following does not show geometrical isomerism? [2002]
- 1,2-dichloro-1-pentene
  - 1,3-dichloro-2-pentene
  - 1,1-dichloro-1-pentene
  - 1,4-dichloro-2-pentene
4. The functional group, which is found in amino acid is [2002]
- $-\text{COOH}$  group
  - $-\text{NH}_2$  group
  - $-\text{CH}_3$  group
  - both (a) and (b).
5. Which of the following compounds has wrong IUPAC name? [2002]
- $\text{CH}_3-\text{CH}_2-\text{CH}_2-\text{COO}-\text{CH}_2\text{CH}_3 \rightarrow$  ethyl butanoate
  - $\text{CH}_3-\underset{\text{CH}}{\text{CH}}-\text{CH}_2-\text{CHO} \rightarrow$  3-methyl-butanal
  - $\text{CH}_3-\underset{\text{OH}}{\text{CH}}-\underset{\text{CH}_3}{\text{CH}}-\text{CH}_3 \rightarrow$  2-methyl-3-butanol
- (d)  $\text{CH}_3-\underset{\text{CH}_3}{\text{CH}}-\overset{\text{O}}{\parallel}{\text{C}}-\text{CH}_2-\text{CH}_3 \rightarrow$  2-methyl-3-pentanone
6. The IUPAC name of  $\text{CH}_3\text{COCH}(\text{CH}_3)_2$  is [2003]
- 2-methyl-3-butanone
  - 4-methylisopropyl ketone
  - 3-methyl-2-butanone
  - Isopropylmethyl ketone
7. In which of the following species is the underlined carbon having  $sp^3$  hybridisation? [2002]
- $\text{CH}_3\underline{\text{C}}\text{OOH}$
  - $\text{CH}_3\underline{\text{C}}\text{H}_2\text{OH}$
  - $\text{CH}_3\underline{\text{C}}\text{OCH}_3$
  - $\text{CH}_2=\underline{\text{C}}\text{H}-\text{CH}_3$
8. Racemic mixture is formed by mixing two [2002]
- isomeric compounds
  - chiral compounds
  - meso compounds
  - enantiomers with chiral carbon.
9. Following types of compounds (as I, II) [2002]
- $$\begin{array}{ccc} \text{CH}_3\text{CH}=\text{CHCH}_3 & \text{CH}_3\text{CHOH} \\ \text{I} & | \\ & \text{CH}_2\text{CH}_3 \\ & \text{II} \end{array}$$
- are studied in terms of isomerism in:
- chain isomerism
  - position isomerism
  - conformers
  - stereoisomerism
10. The reaction: [2002]
- $$(\text{CH}_3)_3\text{C}-\text{Br} \xrightarrow{\text{H}_2\text{O}} (\text{CH}_3)_3\text{C}-\text{OH}$$
- elimination reaction
  - substitution reaction
  - free radical reaction
  - displacement reaction.



11. In the anion  $\text{HCOO}^-$  the two carbon-oxygen bonds are found to be of equal length. what is the reason for it ?

[2003]

- (a) The  $\text{C}=\text{O}$  bond is weaker than the  $\text{C}-\text{O}$  bond  
 (b) The anion  $\text{HCOO}^-$  has two resonating structures  
 (c) The anion is obtained by removal of a proton from the acid molecule  
 (d) Electronic orbitals of carbon atom are hybridised

12. The general formula  $\text{C}_n\text{H}_{2n}\text{O}_2$  could be for open chain

- (a) carboxylic acids (b) diols [2003]  
 (c) dialdehydes (d) diketones

13. Among the following four structures I to IV, [2003]

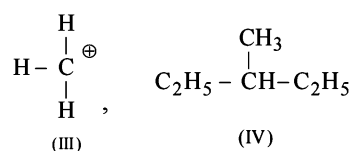
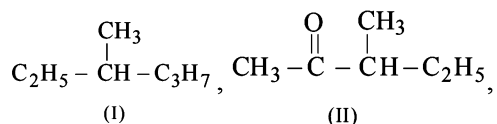

it is true that

- (a) only I and II are chiral compounds  
 (b) only III is a chiral compound  
 (c) only II and IV are chiral compounds  
 (d) all four are chiral compounds
14. Which one of the following has the minimum boiling point ?
- (a) 1 - Butene (b) 1 - Butyne [2004]  
 (c) n- Butane (d) isobutane

15. The IUPAC name of the compound is

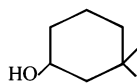

- (a) 3, 3-dimethyl - 1- cyclohexanol [2004]  
 (b) 1, 1-dimethyl-3-hydroxy cyclohexane  
 (c) 3, 3-dimethyl-1-hydroxy cyclohexane  
 (d) 1, 1-dimethyl-3-cyclohexanol

16. Which one of the following does not have  $\text{sp}^2$  hybridized carbon ? [2004]

- (a) Acetonitrile (b) Acetic acid  
 (c) Acetone (d) Acetamide

17. Which of the following will have a mesoisomer also?

- (a) 2, 3- Dichloropentane [2004]  
 (b) 2, 3-Dichlorobutane  
 (c) 2-Chlorobutane  
 (d) 2-Hydroxypropanoic acid

18. Rate of the reaction [2004]

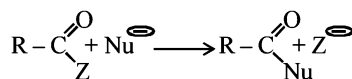

is fastest when Z is

- (a)  $\text{OC}_2\text{H}_5$  (b)  $\text{NH}_2$   
 (c)  $\text{Cl}$  (d)  $\text{OCOCH}_3$

19. Amongst the following compounds, the optically active alkane having lowest molecular mass is [2004]

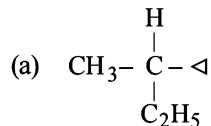

- (b)  $\text{CH}_3-\text{CH}_2-\overset{\text{CH}_3}{\underset{|}{\text{C}}}-\text{H}-\text{CH}_3$   
 (c)  $\text{CH}_3-\text{CH}_2-\text{CH}_2-\text{CH}_3$   
 (d)  $\text{CH}_3-\text{CH}_2-\text{C}\equiv\text{CH}$

20. Consider the acidity of the carboxylic acids :

- (a)  $\text{PhCOOH}$  (b)  $\text{o-NO}_2\text{C}_6\text{H}_4\text{COOH}$   
 (c)  $\text{p-NO}_2\text{C}_6\text{H}_4\text{COOH}$  (d)  $\text{m-NO}_2\text{C}_6\text{H}_4\text{COOH}$

Which of the following order is correct ? [2004]

- (a)  $2 > 4 > 1 > 3$  (b)  $2 > 4 > 3 > 1$   
 (c)  $1 > 2 > 3 > 4$  (d)  $2 > 3 > 4 > 1$

21. Which of the following is the strongest base ?

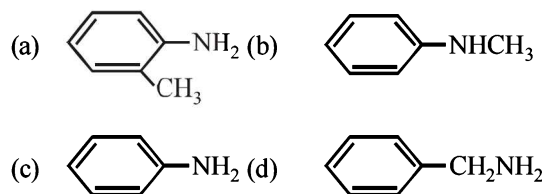

22. Which of the following compounds is not chiral?

- (a) 1-chloro-2-methyl pentane [2004]  
 (b) 2-chloropentane  
 (c) 1-chloropentane  
 (d) 3-chloro-2-methyl pentane

23. Due to the presence of an unpaired electron, free radicals are: [2005]

- (a) cations (b) anions  
 (c) chemically inactive (d) chemically reactive

24. The decreasing order of nucleophilicity among the nucleophiles [2005]

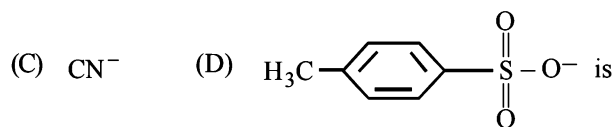
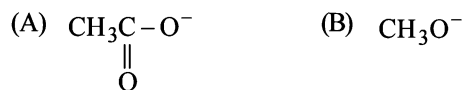

- (a) (C), (B), (A), (D) (b) (B), (C), (A), (D)  
 (c) (D), (C), (B), (A) (d) (A), (B), (C), (D)

25. The reaction

[2005]

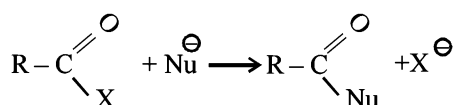

is fastest when X is

- (a) OCOR                      (b) OC<sub>2</sub>H<sub>5</sub>  
(c) NH<sub>2</sub>                      (d) Cl

26. The IUPAC name of the compound shown below is :

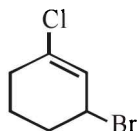

- (a) 3-bromo-1-chlorocyclohexene                      [2006]  
(b) 1-bromo-3-chlorocyclohexene  
(c) 2-bromo-6-chlorocyclohex-1-ene  
(d) 6-bromo-2-chlorocyclohexene

27. The increasing order of stability of the following free radicals is

[2006]

- (a) (C<sub>6</sub>H<sub>5</sub>)<sub>2</sub>ĊH < (C<sub>6</sub>H<sub>5</sub>)<sub>3</sub>Ċ < (CH<sub>3</sub>)<sub>3</sub>Ċ < (CH<sub>3</sub>)<sub>2</sub>ĊH  
(b) (CH<sub>3</sub>)<sub>2</sub>ĊH < (CH<sub>3</sub>)<sub>3</sub>Ċ < (C<sub>6</sub>H<sub>5</sub>)<sub>2</sub>ĊH < (C<sub>6</sub>H<sub>5</sub>)<sub>3</sub>Ċ  
(c) (CH<sub>3</sub>)<sub>2</sub>ĊH < (CH<sub>3</sub>)<sub>3</sub>Ċ < (C<sub>6</sub>H<sub>5</sub>)<sub>2</sub>ĊH < (C<sub>6</sub>H<sub>5</sub>)<sub>3</sub>Ċ  
(d) (C<sub>6</sub>H<sub>5</sub>)<sub>3</sub>Ċ < (C<sub>6</sub>H<sub>5</sub>)<sub>2</sub>ĊH < (CH<sub>3</sub>)<sub>3</sub>Ċ < (CH<sub>3</sub>)<sub>2</sub>ĊH

28. CH<sub>3</sub>Br + Nu<sup>-</sup> → CH<sub>3</sub>-Nu + Br<sup>-</sup> The decreasing order of the rate of the above reaction with nucleophiles (Nu<sup>-</sup>) A to D is

[2006]

[Nu<sup>-</sup> = (A) PhO<sup>-</sup>, (B) AcO<sup>-</sup>, (C) HO<sup>-</sup>, (D) CH<sub>3</sub>O<sup>-</sup>]

- (a) A > B > C > D                      (b) B > D > C > A  
(c) D > C > A > B                      (d) D > C > B > A

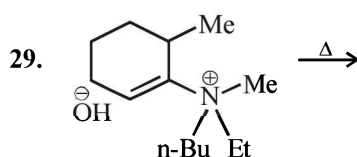

The alkene formed as a major product in the above elimination reaction is

[2006]

- (a)                      (b)   
(c)                      (d) CH<sub>2</sub>=CH<sub>2</sub>

30. Increasing order of stability among the three main conformations (i.e. Eclipse, Anti, Gauche) of 2-fluoroethanol is

[2006]

- (a) Eclipse, Anti, Gauche  
(b) Anti, Gauche, Eclipse  
(c) Eclipse, Gauche, Anti  
(d) Gauche, Eclipse, Anti

31. The IUPAC name of is

- (a) 3-ethyl-4,4-dimethylheptane                      [2007]  
(b) 1, 1-diethyl-2,2-dimethylpentane  
(c) 4, 4-dimethyl-5,5-diethylpentane  
(d) 5, 5-diethyl-4,4-dimethylpentane.

32. Which of the following molecules is expected to rotate the plane of plane-polarised light? [2007]

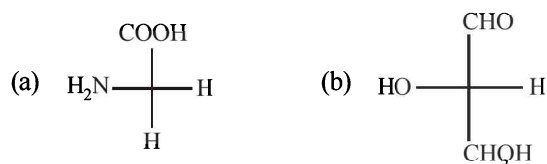

33. Presence of a nitro group in a benzene ring [2007]

- (a) deactivates the ring towards electrophilic substitution  
(b) activates the ring towards electrophilic substitution  
(c) renders the ring basic  
(d) deactivates the ring towards nucleophilic substitution.

34. Which one of the following conformations of cyclohexane is chiral? [2007]

- (a) Boat                      (b) Twist boat  
(c) Rigid                      (d) Chair.

35. The absolute configuration of [2008]

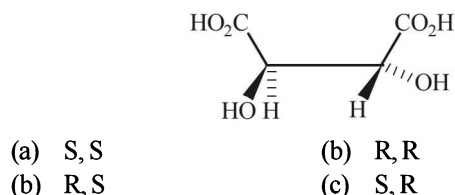
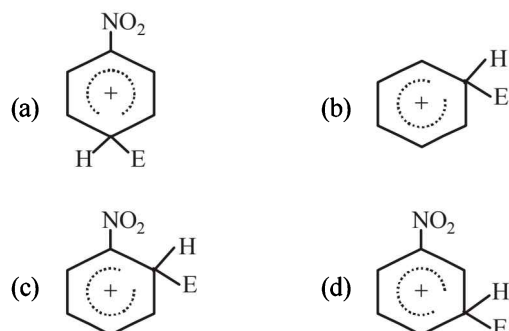
36. The electrophile, E<sup>+</sup> attacks the benzene ring to generate the intermediate σ-complex. Of the following, which σ-complex is lowest energy? [2008]

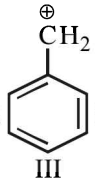
37. The correct decreasing order of priority for the functional groups of organic compounds in the IUPAC system of nomenclature is [2008]
- (a)  $-\text{COOH}, -\text{SO}_3\text{H}, -\text{CONH}_2, -\text{CHO}$   
 (b)  $-\text{SO}_3\text{H}, -\text{COOH}, -\text{CONH}_2, -\text{CHO}$   
 (c)  $-\text{CHO}, -\text{COOH}, -\text{SO}_3\text{H}, -\text{CONH}_2$   
 (d)  $-\text{CONH}_2, -\text{CHO}, -\text{SO}_3\text{H}, -\text{COOH}$
38. The IUPAC name of neopentane is [2009]
- (a) 2, 2 dimethylpropane  
 (b) 2 methylpropane  
 (c) 2, 2 dimethylbutane  
 (d) 2-methylbutane
39. Arrange the carbanions, [2009]
- $(\text{CH}_3)_3\bar{\text{C}}, \bar{\text{C}}\text{Cl}_3, (\text{CH}_3)_2\bar{\text{C}}\text{H}, \text{C}_6\text{H}_5\bar{\text{C}}\text{H}_2$  in order of their decreasing stability :
- (a)  $(\text{CH}_3)_2\bar{\text{C}}\text{H} > \bar{\text{C}}\text{Cl}_3 > \text{C}_6\text{H}_5\bar{\text{C}}\text{H}_2 > (\text{CH}_3)_3\bar{\text{C}}$   
 (b)  $\bar{\text{C}}\text{Cl}_3 > \text{C}_6\text{H}_5\bar{\text{C}}\text{H}_2 > (\text{CH}_3)_2\bar{\text{C}}\text{H} > (\text{CH}_3)_3\bar{\text{C}}$   
 (c)  $(\text{CH}_3)_3\bar{\text{C}} > (\text{CH}_3)_2\bar{\text{C}}\text{H} > \text{C}_6\text{H}_5\bar{\text{C}}\text{H}_2 > \bar{\text{C}}\text{Cl}_3$   
 (d)  $\text{C}_6\text{H}_5\bar{\text{C}}\text{H}_2 > \bar{\text{C}}\text{Cl}_3 > (\text{CH}_3)_3\bar{\text{C}} > (\text{CH}_3)_2\bar{\text{C}}\text{H}$
40. The alkene that exhibits geometrical isomerism is: [2009]
- (a) 2- methyl propene  
 (b) 2-butene  
 (c) 2- methyl -2- butene  
 (d) propene
41. The number of stereoisomers possible for a compound of the molecular formula  $\text{CH}_3-\text{CH}=\text{CH}-\text{CH}(\text{OH})-\text{Me}$  is: [2009]
- (b) 2 (c) 4  
 (d) 6 (d) 3
42. The correct order of increasing basicity of the given conjugate bases ( $\text{R} = \text{CH}_3$ ) is [2010]
- (a)  $\text{RCOO}^- < \text{HC} \equiv \bar{\text{C}} < \bar{\text{R}} < \bar{\text{N}}\text{H}_2$   
 (b)  $\bar{\text{R}} < \text{HC} \equiv \bar{\text{C}} < \text{RCOO}^- < \bar{\text{N}}\text{H}_2$   
 (c)  $\text{RCOO}^- < \bar{\text{N}}\text{H}_2 < \text{HC} \equiv \bar{\text{C}} < \bar{\text{R}}$   
 (d)  $\text{RCOO}^- < \text{HC} \equiv \bar{\text{C}} < \bar{\text{N}}\text{H}_2 < \bar{\text{R}}$
43. Out of the following, the alkene that exhibits optical isomerism is [2010]
- (a) 3-methyl-2-pentene (b) 4-methyl-1-pentene  
 (c) 3-methyl-1-pentene (d) 2-methyl-2-pentene
44. Identify the compound that exhibits tautomerism : [2011]
- (a) 2-Butene (b) Lactic acid  
 (c) 2-Pentanone (d) Phenol
45. A solution of (–)-1-chloro-1-phenylethane in toluene racemises slowly in the presence of a small amount of  $\text{SbCl}_5$ , due to the formation of: [JEE M 2013]
- (a) carbanion (b) carbene  
 (c) carbocation (d) free radical
46. The order of stability of the following carbocations :
- $\text{CH}_2 = \text{CH} - \overset{\oplus}{\text{C}}\text{H}_2$  ;  $\text{CH}_3 - \text{CH}_2 - \overset{\oplus}{\text{C}}\text{H}_2$  ;  is :
- (a) III > II > I (b) II > III > I  
 (c) I > II > III (d) III > I > II
47. For the estimation of nitrogen, 1.4 g of an organic compound was digested by Kjeldahl method and the evolved ammonia was absorbed in 60 mL of  $\frac{M}{10}$  sulphuric acid. The unreacted acid required 20 mL of  $\frac{M}{10}$  sodium hydroxide for complete neutralization. The percentage of nitrogen in the compound is: [JEE M 2014]
- (a) 6% (b) 10%  
 (c) 3% (d) 5%
48. Which of the following compounds will exhibit geometrical isomerism ? [JEE M 2015]
- (a) 2-Phenyl -1 - butene  
 (b) 1, 1 - Diphenyl - 1 - propene  
 (c) 1 - Phenyl - 2 - butene  
 (d) 3 - Phenyl -1 - butene
49. In Carius method of estimation of halogens, 250 mg of an organic compound gave 141 mg of  $\text{AgBr}$ . The percentage of bromine in the compound is : [JEE M 2015]
- (at. mass  $\text{Ag}=108, \text{Br}=80$ )
- (a) 48 (b) 60  
 (c) 24 (d) 36

50. The absolute configuration of

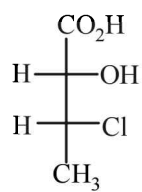

is :

- (a) (2S, 3S)                      (b) (2R, 3R)  
(c) (2R, 3S)                      (d) (2S, 3R)

[JEE M 2016]

51. The distillation technique most suited for separating glycerol from spent-lye in the soap industry is :

[JEE M 2016]

- (a) Steam distillation.  
(b) Distillation under reduced pressure.  
(c) Simple distillation  
(d) Fractional distillation

## CHAPTER

## 10

## Hydrocarbons

## Section-A JEE Advanced/ IIT-JEE

## A Fill in the Blanks

- ..... is most acidic.  
(Ethane, Ethene, Ethyne) (1981 - 1 Mark)
- Acetylene is treated with excess sodium in liquid ammonia. The product is reacted with excess methyl iodide. The final product is ..... (1983 - 1 Mark)
- The starting material for the manufacture of polyvinyl chloride is obtained by reacting HCl with ..... (1983 - 1 Mark)
- Kolbe electrolysis of potassium succinate gives  $\text{CO}_2$  and ..... (1993 - 1 Mark)
- Addition of water to acetylenic compounds is catalyzed by.....and..... (1993 - 1 Mark)
- The bond dissociation energy needed to form the benzyl radical from toluene is.....than the formation of the methyl radical from methane. (1994 - 1 Mark)
- 1, 3-Butadiene with bromine in molar ratio generates predominantly ..... (1997 - 1 Mark)
- The compound with the highest boiling point is (1982 - 1 Mark)
  - n*-hexane
  - n*-pentane
  - 2, 2-dimethylpropane
  - 2-methylbutane
- The maximum number of isomers for an alkene with the molecular formula  $\text{C}_4\text{H}_8$  is (1982 - 1 Mark)
  - 2
  - 3
  - 4
  - 5
- When propyne is treated with aqueous  $\text{H}_2\text{SO}_4$  in presence of  $\text{HgSO}_4$  the major product is (1983 - 1 Mark)
  - propanal
  - propyl hydrogensulphate
  - acetone
  - propanol
- Which of the following compounds does not dissolve in conc.  $\text{H}_2\text{SO}_4$  even on warming? (1983 - 1 Mark)
  - ethylene
  - benzene
  - hexane
  - aniline
- Baeyer's reagent is : (1984 - 1 Mark)
  - alkaline permanganate solution
  - acidified permanganate solution
  - neutral permanganate solution
  - aqueous bromine solution
- Acidic hydrogen is present in : (1985 - 1 Mark)
  - ethyne
  - ethene
  - benzene
  - ethane
- Anti*-Markovnikoff addition of HBr is not observed in : (1985 - 1 Mark)
  - propene
  - 1-butene
  - but-2-ene
  - pent-2-ene

## B True / False

- Moist ethylene can be dried by passing it through concentrated sulphuric acid. (1982 - 1 Mark)
- Photobromination of 2-methylpropane gives a mixture of 1-bromo-2-methylpropane and 2-bromo-2-methylpropane in the ratio of 9: 1. (1993 - 1 Mark)

## C MCQs with One Correct Answer

- Marsh gas mainly contains (1980)
  - $\text{C}_2\text{H}_2$
  - $\text{CH}_4$
  - $\text{H}_2\text{S}$
  - $\text{CO}$
- Which of the following decolourises alkaline  $\text{KMnO}_4$  solution (1980)
  - $\text{C}_3\text{H}_8$
  - $\text{C}_2\text{H}_4$
  - $\text{CH}_4$
  - $\text{CCl}_4$
- The highest boiling point is expected for : (1986 - 1 Mark)
  - iso-octane
  - n*-octane
  - 2, 2, 3, 3-tetramethylbutane
  - n*-butane
- Which of the following will have least hindered rotation about carbon-carbon bond? (1987 - 1 Mark)
  - Ethane
  - Ethylene
  - Acetylene
  - Hexachloroethane

12. When cyclohexane is poured on water, it floats, because:  
 (a) cyclohexane is in 'boat' form (1997 - 1 Mark)  
 (b) cyclohexane is in 'chair' form  
 (c) cyclohexane is in 'crown' form  
 (d) cyclohexane is less dense than water.

13. The product(s) obtained via oxymercuration ( $\text{HgSO}_4 + \text{H}_2\text{SO}_4$ ) of 1-butyne would be (1999 - 2 Marks)

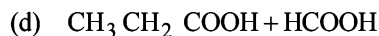
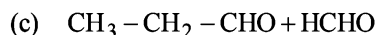
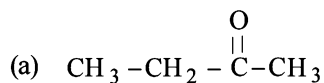

14. Propyne and propene can be distinguished by (2000S)

- (a) conc.  $\text{H}_2\text{SO}_4$  (b)  $\text{Br}_2$  in  $\text{CCl}_4$   
 (c) dil.  $\text{KMnO}_4$  (d)  $\text{AgNO}_3$  in ammonia

15. Which one of the following will react fastest with  $\text{H}_2$  under catalytic hydrogenation condition? (2000S)

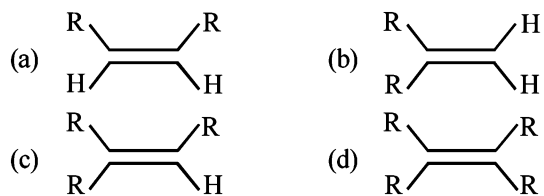

16. In the presence of peroxide, hydrogen chloride and hydrogen iodide do not give *anti*-Markovnikov addition to alkenes because (2001S)

- (a) both are highly ionic  
 (b) one is oxidizing and the other is reducing  
 (c) one of the steps is endothermic in both the cases  
 (d) all the steps are exothermic in both the cases

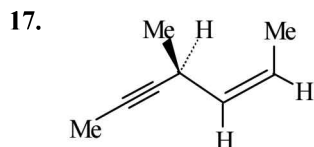

Hydrogenation of the above compound in the presence of poisoned palladium catalyst gives (2001S)

- (a) an optically active compound  
 (b) an optically inactive compound  
 (c) a racemic mixture  
 (d) a diastereomeric mixture

18. The reaction of propene with  $\text{HOCl}$  proceeds via the addition of (2001S)

- (a)  $\text{H}^+$  in the first step  
 (b)  $\text{Cl}^+$  in the first step  
 (c)  $\text{OH}^-$  in the first step  
 (d)  $\text{Cl}^+$  and  $\text{OH}^-$  in a single step

19. The nodal plane in the  $\pi$ -bond of ethene is located in

- (a) the molecular plane (2002S)  
 (b) a plane parallel to the molecular plane  
 (c) a plane perpendicular to the molecular plane which bisects the carbon - carbon  $\sigma$ -bond at right angle  
 (d) a plane perpendicular to the molecular plane which contains the carbon - carbon  $\sigma$ -bond.

20. Consider the following reaction (2002S)

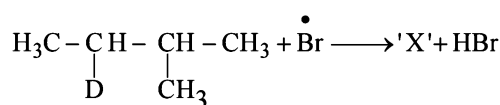

Identify the structure of the major product 'X'

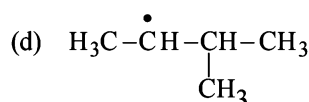
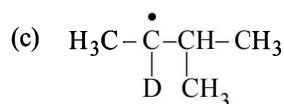
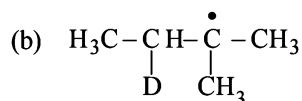
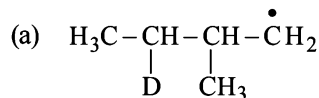

21. Identify the reagent from the following list which can easily distinguish between 1-butyne and 2-butyne (2002S)

- (a) bromine,  $\text{CCl}_4$   
 (b)  $\text{H}_2$ , Lindlar catalyst  
 (c) dilute  $\text{H}_2\text{SO}_4$ ,  $\text{HgSO}_4$   
 (d) ammonical  $\text{Cu}_2\text{Cl}_2$  solution

22.  $\text{Ph} - \text{C} \equiv \text{C} - \text{CH}_3 \xrightarrow{\text{Hg}^{2+}/\text{H}^+} \text{A}$ . A is: (2003S)

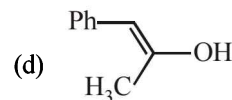
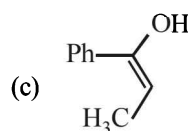
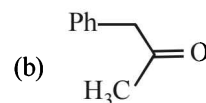
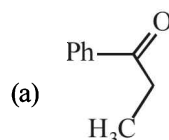

23. Which of the following is used for the conversion of 2-hexyne into *trans*-2-hexene? (2004S)

- (a)  $\text{H}_2/\text{Pd}/\text{BaSO}_4$  (b)  $\text{H}_2$ ,  $\text{PtO}_2$   
 (c)  $\text{NaBH}_4$  (d)  $\text{Li-NH}_3/\text{C}_2\text{H}_5\text{OH}$

24. On monochlorination of 2-methylbutane, the total number of chiral compounds formed is (2004S)

- (a) 2 (b) 4  
 (c) 6 (d) 8

25. Identify the product, P in the following reaction :

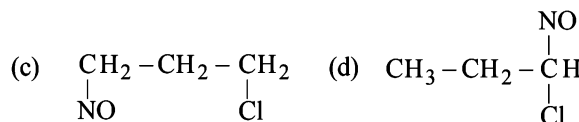
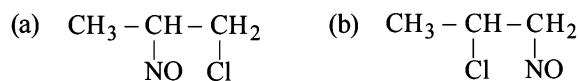
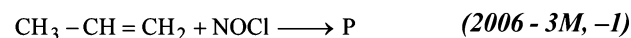

26. Cyclohexene on ozonolysis followed by reaction with zinc dust and water gives compound E. Compound E on further treatment with aqueous KOH yields compound F. Compound F is (2007)

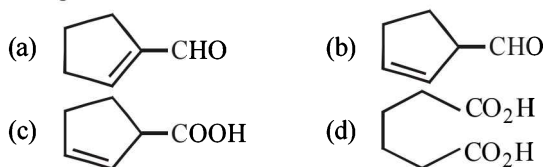

27. The synthesis of 3-octyne is achieved by adding a bromoalkane into a mixture of sodium amide and an alkyne. The bromoalkane and alkyne respectively are (2010)

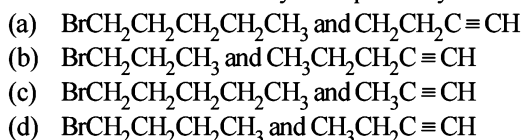

28. The bond energy (in  $\text{kcal mol}^{-1}$ ) of a C-C single bond is approximately (2010)

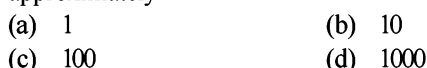

29. In allene ( $\text{C}_3\text{H}_4$ ), the type(s) of hybridisation of the carbon atoms is (are): (2012)



30. The number of optically active products obtained from the complete ozonolysis of the given compound is: (2012)

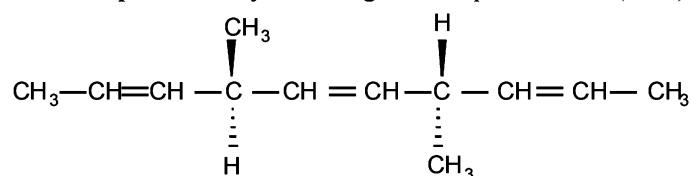

31. Isomers of hexane, based on their branching, can be divided into three distinct classes as shown in the figure. (JEE Adv. 2014)

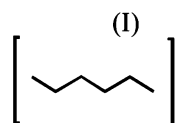
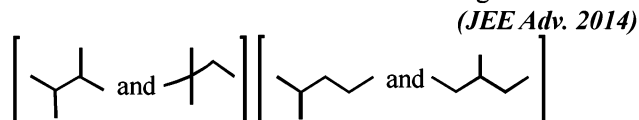

The correct order of their boiling point is



### D MCQs with One or More Than One Correct

1. Which one of the following has the smallest heat of hydrogenation per mole? (1993 - 1 Mark)

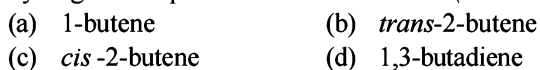

2. Toluene, when treated with  $\text{Br}_2/\text{Fe}$ , gives *p*-bromotoluene as the major product because  $\text{CH}_3$  group (1999 - 3 Marks)

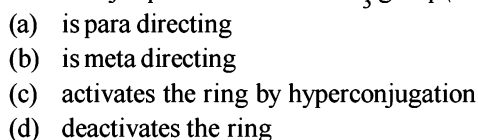

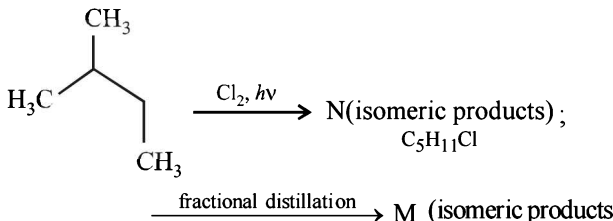
3. 

Identify N and M (2006 - 5M, -1)



4. Among P, Q, R and S, the aromatic compound(s) is/are (JEE Advanced 2013-I)

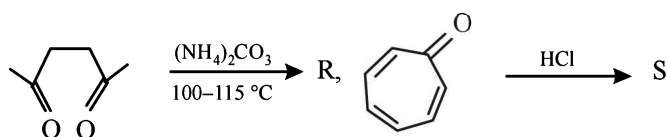
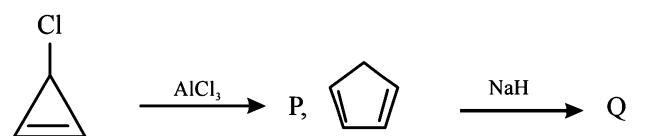

5. In the following reaction, the major product is (JEE Adv. 2015)

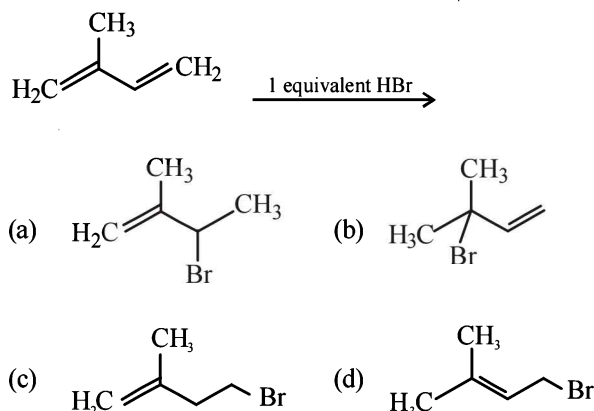

6. Compound(s) that on hydrogenation produce(s) optically inactive compound(s) is (are) (JEE Adv. 2015)

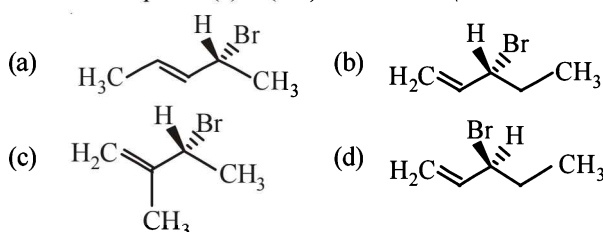

7. Among the following, reaction(s) which gives(give) tert-butyl benzene as the major product is(are)

(JEE Adv. 2016)

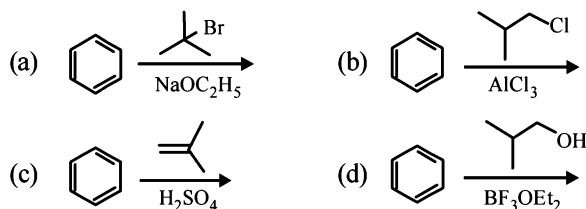

## E Subjective Problems

1. Give one characteristic test which would distinguish  $\text{CH}_4$  from  $\text{C}_2\text{H}_2$  (1979)
2. Write the structural formula of the major product in each of the following cases :

(i) the compound obtained by the hydration of ethyne is treated with dilute alkali (1981 - 1/2 Mark)

(ii) ethene mixed with air is passed under pressure over a silver catalyst at  $250^\circ\text{C}$ . (1981 - 1/2 Mark)

(iii)  +  $(\text{CH}_3)_2\text{CHCH}_2\text{Cl} \xrightarrow{\text{AlCl}_3}$  (1992 - 1 Mark)

(iv)  $\text{C}_6\text{H}_6 + (\text{CH}_3)_2\text{CHCH}_2\text{OH} \xrightarrow{\text{H}_2\text{SO}_4}$  (1994 - 1 Mark)

(v)  $\text{C}_6\text{H}_5\text{C}_2\text{H}_5 \xrightarrow[2. \text{NaCN}]{1. \text{Br}_2, \text{Heat, Light}}$  (1994 - 1 Mark)

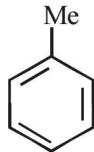
(vi)  +  $\text{H}_3\text{C}-\overset{\text{CH}_3}{\underset{\text{H}}{\text{C}}}-\text{CH}_2\text{Br}$   
+ Anhyd.  $\text{AlCl}_3 \longrightarrow$  (1997 - 1 Mark)

(vii)  +  $\text{CHBr}_3 + t\text{-BuOK} \longrightarrow$  (1997 - 1 Mark)

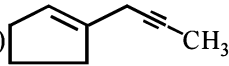
(viii)   $\xrightarrow[\text{Lindlar catalyst}]{\text{H}_2}$  (2000 - 1 Mark)

3. Outline the reaction sequence for the conversion of ethene to ethyne (the number of steps should not be more than two). (1981 - 1 Mark)
4. State with balanced equations, what happens when propene is bubbled through a hot aqueous solution of potassium permanganate. (1982 - 1 Mark)
5. Give reasons for the following :
- (i) Methane does not react with chlorine in the dark. (1983 - 1 Mark)
- (ii) Propene reacts with  $\text{HBr}$  to give isopropyl bromide but does not give n-propyl bromide. (1983 - 1 Mark)
- (iii) Although benzene is highly unsaturated, normally it does not undergo addition reaction. (1983 - 1 Mark)

(iv) Toluene reacts with bromine in the presence of light to give benzyl bromide while in presence of  $\text{FeBr}_3$  it gives p-bromotoluene. Give explanation for the above observations. (1996 - 2 Marks)

(v) The central carbon-carbon bond in 1, 3 - butadiene is shorter than that in n-butane. (1998 - 2 Marks)

(vi) tert-Butylbenzene does not give benzoic acid on treatment with acidic  $\text{KMnO}_4$ . (2000 - 1 Mark)

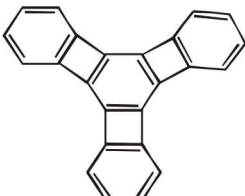
(vii)   $\xrightarrow{3\text{H}_2/\text{Pd}}$  (2005 - 1 Mark)

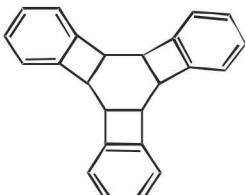
 but not (A)

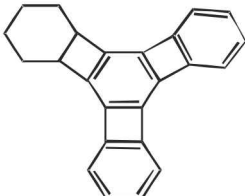
 (B)

6. (i) 2-Methylpropene can be converted into isobutyl bromide by hydrogen bromide, is true under what conditions? (1984 - 1 Mark)
- (ii) 'Ethyne and its derivatives will give white precipitate with ammonical silver nitrate solution', is true under what conditions. (1984 - 1 Mark)
7. Write down the reactions involved in the preparation of the following, using the reagents indicated against it in parenthesis.  
Ethylbenzene from benzene [ $\text{C}_2\text{H}_5\text{OH}$ ,  $\text{PCl}_5$ , anhydrous  $\text{AlCl}_3$ ]. (1984 - 2 Marks)
8. A certain hydrocarbon A was found to contain 85.7 percent carbon and 14.3 per cent hydrogen. This compound consumes 1 molar equivalent of hydrogen to give a saturated hydrocarbon B. 1.00 g of hydrocarbon A just decolourized 38.05 g of a 5 per cent solution (by weight) of  $\text{Br}_2$  in  $\text{CCl}_4$ . Compound A, on oxidation with concentrated  $\text{KMnO}_4$ , gave compound C (molecular formula  $\text{C}_4\text{H}_8\text{O}$ ) and acetic acid. Compound C could easily be prepared by the action of acidic aqueous mercuric sulphate on 2- butyne. Determine the molecular formula of A and deduce the structure of A, B and C. (1984 - 6 Marks)
9. How would you distinguish between
- (i) 2-butyne and 1-butyne. (1985 - 1 Mark)
- (ii) cyclohexane and cyclohexene. (1988 - 1 Mark)



10. *n*-Butane is produced by the monobromination of ethane followed by the Wurtz reaction. Calculate the volume of ethane at NTP required to produce 55 g *n*-butane, if the bromination takes place with 90 per cent yield and the Wurtz reaction with 85 per cent yield. (1989 - 3 Marks)
11. Identify, **B**( $C_4H_8$ ) which adds on HBr in the presence and in the absence of peroxide to give the same product,  $C_4H_9Br$ . (1993 - 1 Mark)
12. Identify, **D**( $C_6H_{12}$ ), an optically active hydrocarbon which on catalytic hydrogenation gives an optically inactive compound,  $C_6H_{14}$ . (1993 - 1 Mark)
13. Draw the stereochemical structures of the products in the following reactions : (1994 - 4 Marks)

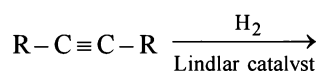

14. 1,4-Pentadiene reacts with excess of HCl in the presence of benzoyl peroxide to give compound X which upon reaction with excess of Mg in dry ether forms Y. Compound Y on treatment with ethyl acetate followed by dilute acid yields Z. Identify the structures of compounds X, Y and Z. (1995 - 4 Marks)
15. An organic compound **E**( $C_5H_8$ ) on hydrogenation gives compound **F**( $C_5H_{12}$ ). Compound **E** on ozonolysis gives formaldehyde and 2-ketopropanal. Deduce the structure of compound **E**. (1995 - 2 Marks)
16. Optically active 2-iodobutane on treatment with NaI in acetone gives a product which does not show optical activity. Explain briefly. (1995 - 2 Marks)
17. A hydrocarbon **A**, of the formula  $C_8H_{10}$ , on ozonolysis gives compound **B**( $C_4H_6O_2$ ) only. The compound **B** can also be obtained from the alkyl bromide,  $C(C_3H_5Br)$  upon treatment with magnesium in dry ether, followed by carbon dioxide and acidification. Identify **A**, **B** and **C** and also give equations for the reactions. (1996 - 3 Marks)
18. Give the structures of the major organic products from 3-ethyl-2-pentene under each of the following reaction conditions. (1996 - 3 Marks)
- HBr in the presence of peroxide
  - $Br_2/H_2O$
  - $Hg(OAc)_2/H_2O$ ;  $NaBH_4$
19. The hydrocarbon **A**, adds one mole of hydrogen in the presence of a platinum catalyst to form *n*-hexane. When **A** is oxidized vigorously with  $KMnO_4$ , a single carboxylic acid, containing three carbon atoms, is isolated. Give the structure of **A** and explain. (1997 - 2 Marks)
20. Show the steps to carry out the following transformations. (1998 - 2 Marks)
- Ethylbenzene  $\rightarrow$  benzene
  - Ethylbenzene  $\rightarrow$  2-phenylpropionic acid.
- (1998 - 3 Marks)
21. Complete the following reactions with appropriate structures of products/reagents.

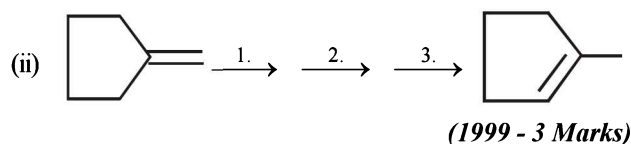
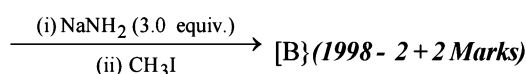
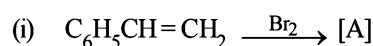

22. An alkene (**A**)  $C_{16}H_{16}$  on ozonolysis gives only one product (**B**)  $C_8H_8O$ . Compound (**B**) on reaction with  $NaOH/I_2$  yields sodium benzoate. Compound (**B**) reacts with  $KOH/NH_2NH_2$  yielding a hydrocarbon (**C**)  $C_8H_{10}$ . Write the structures of compounds (**B**) and (**C**). Based on this information, two isomeric structures can be proposed for alkene (**A**). Write their structures and identify the isomer which on catalytic hydrogenation ( $H_2/Pd-C$ ) gives a racemic mixture. (2001 - 5 Marks)
23. Write down the heterogeneous catalyst involved in the polymerisation of ethylene. (2003 - 2 Marks)
24.  $A(C_6H_{12}) \xrightarrow{HCl} B + C$  (2003 - 4 Marks)
- $(C_6H_{13}Cl)$
- $B \xrightarrow{\text{alc. KOH}} D$  (isomer of **A**)
- $D \xrightarrow{\text{ozonolysis}} E$  (it gives negative test with Fehling solution but responds to iodoform test).
- $A \xrightarrow{\text{Ozonolysis}} F + G$  (both gives positive Tollen's test but do not give iodoform test).
- $F + G \xrightarrow{\text{conc. NaOH}} HCOONa + A$  primary alcohol.
- Identify from **A** to **G**.
25. Draw Newmann projection of relatively less stable staggered form of *n*-butane. The reason of low stability of this form is van der Waal's repulsion, torsional strain, or both. (2004 - 2 Marks)

## G Comprehension Based Questions

### PASSAGE-I

An acyclic hydrocarbon **P**, having molecular formula  $C_6H_{10}$ , gave acetone as the only organic product through the following sequence of reactions, in which **Q** is an intermediate organic compound.

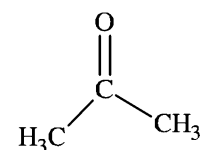
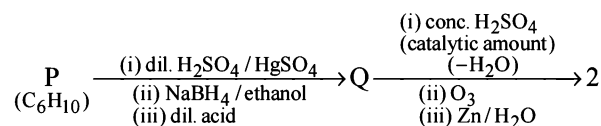

(2011 - I)

1. The structure of compound **P** is
- $CH_3CH_2CH_2CH_2C\equiv CH$
  - $CH_3CH_2C\equiv CCH_2CH_3$

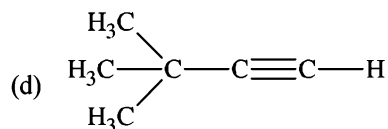
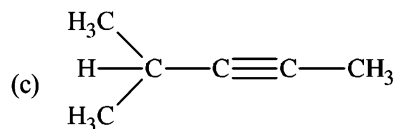

2. The structure of the compound Q is

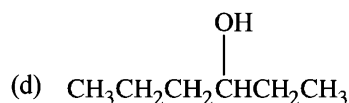
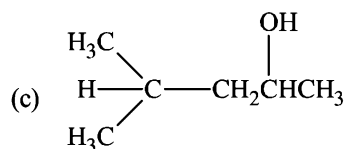
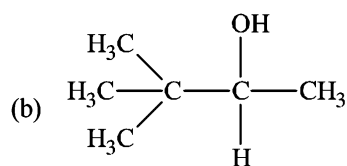
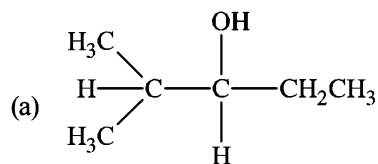

### PASSAGE - II

Schemes 1 and 2 describe sequential transformation of alkynes *M* and *N*. Consider only the major products formed in each step for both the schemes.

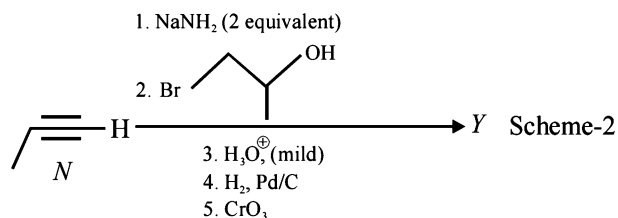
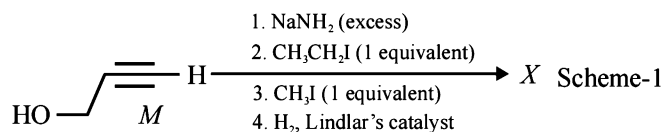

3. The product *X* is

(JEE Adv. 2014)

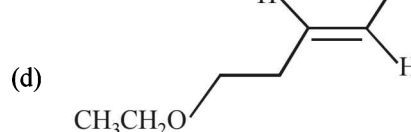
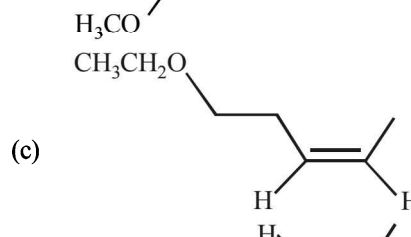
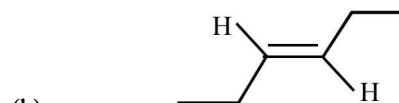
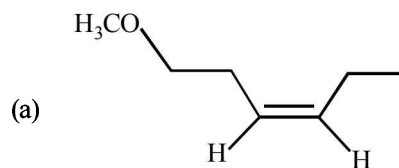

4. The correct statement with respect to product *Y* is

(JEE Adv. 2014)

- (a) It gives a positive Tollen's test and is a functional isomer of *X*  
 (b) It gives a positive Tollen's test and is a geometrical isomer of *X*  
 (c) It gives a positive iodoform test and is a functional isomer of *X*  
 (d) It gives a positive iodoform test and is a geometrical isomer of *X*

### II Assertion & Reason Type Questions

Read the following statement (Assertion) and explanation (Reason) and answer each question as per the options given below :

- (a) If both *assertion* and *reason* are correct, and *reason* is the correct explanation of the *assertion*.  
 (b) If both *assertion* and *reason* are correct, but *reason* is not the correct explanation of the *assertion*.  
 (c) If *assertion* is correct but *reason* is incorrect.  
 (d) If *assertion* is incorrect but *reason* is correct.

1. **Assertion :** Addition of  $\text{Br}_2$  to 1-butene gives two optical isomers.

**Reason :** The product contains one asymmetric carbon.

(1998 - 2 Marks)

2. **Assertion :** 1-Butene on reaction with HBr in the presence of a peroxide produces 1-bromobutane.

**Reason :** It involves the formation of a primary radical.

(2005)

3. **Assertion :** Addition of bromine to *trans*-2-butene yields *meso*-2,3-dibromobutane.

**Reason :** Bromine addition to an alkene is an electrophilic addition.

(2015)

## Section-B

## JEE Main / AIEEE

- Which of these will not react with acetylene? [2002]
  - NaOH
  - ammonical  $\text{AgNO}_3$
  - Na
  - HCl.
- What is the product when acetylene reacts with hypochlorous acid? [2002]
  - $\text{CH}_3\text{COCl}$
  - $\text{ClCH}_2\text{CHO}$
  - $\text{Cl}_2\text{CHCHO}$
  - $\text{ClCHCOOH}$ .
- On mixing a certain alkane with chlorine and irradiating it with ultraviolet light, it forms only one monochloroalkane. This alkane could be [2003]
  - pentane
  - isopentane
  - neopentane
  - propane
- 2-Methylbutane on reacting with bromine in the presence of sunlight gives mainly [2005]
  - 1-bromo-3-methylbutane
  - 2-bromo-3-methylbutane
  - 2-bromo-2-methylbutane
  - 1-bromo-2-methylbutane
- Butene-1 may be converted to butane by reaction with [2003]
  - $\text{Sn}-\text{HCl}$
  - $\text{Zn}-\text{Hg}$
  - $\text{Pd}/\text{H}_2$
  - $\text{Zn}-\text{HCl}$
- Reaction of one molecule of HBr with one molecule of 1, 3-butadiene at  $40^\circ\text{C}$  gives predominantly [2005]
  - 1-bromo-2-butene under kinetically controlled conditions
  - 3-bromobutene under thermodynamically controlled conditions
  - 1-bromo-2-butene under thermodynamically controlled conditions
  - 3-bromobutene under kinetically controlled conditions
- Of the five isomeric hexanes, the isomer which can give two monochlorinated compounds is [2005]
  - 2-methylpentane
  - 2, 2-dimethylbutane
  - 2, 3-dimethylbutane
  - n-hexane
- Acid catalyzed hydration of alkenes except ethene leads to the formation of
  - mixture of secondary and tertiary alcohols
  - mixture of primary and secondary alcohols
  - secondary or tertiary alcohol
  - primary alcohol
- Which types of isomerism is shown by 2, 3-dichlorobutane? [2005]
  - Structural
  - Geometric
  - Optical
  - Diastereo
- The compound formed as a result of oxidation of ethyl benzene by  $\text{KMnO}_4$  is [2007]
  - benzyl alcohol
  - benzophenone
  - acetophenone
  - benzoic acid.
- Which of the following reactions will yield 2, 2-dibromopropane? [2007]
  - $\text{CH}_3-\text{CH}=\text{CH}_2 + \text{HBr} \rightarrow$
  - $\text{CH}_3-\text{C}\equiv\text{CH} + 2\text{HBr} \rightarrow$
  - $\text{CH}_3\text{CH}=\text{CHBr} + \text{HBr} \rightarrow$
  - $\text{CH}\equiv\text{CH} + 2\text{HBr} \rightarrow$
- The reaction of toluene with  $\text{Cl}_2$  in presence of  $\text{FeCl}_3$  gives predominantly [2007]
  - m-chlorobenzene
  - benzoyl chloride
  - benzyl chloride
  - o- and p-chlorotoluene.
- Toluene is nitrated and the resulting product is reduced with tin and hydrochloric acid. The product so obtained is diazotised and then heated with cuprous bromide. The reaction mixture so formed contains [2008]
  - mixture of o- and p-bromotoluenes
  - mixture of o- and p-dibromobenzenes
  - mixture of o- and p-bromoanilines
  - mixture of o- and m-bromotoluenes
- In the following sequence of reactions, the alkene affords the compound 'B'
 
$$\text{CH}_3-\text{CH}=\text{CH}-\text{CH}_3 \xrightarrow{\text{O}_3} \text{A} \xrightarrow[\text{Zn}]{\text{H}_2\text{O}} \text{B}.$$
 The compound B is [2008]
  - $\text{CH}_3\text{CH}_2\text{CHO}$
  - $\text{CH}_3\text{COCH}_3$
  - $\text{CH}_3\text{CH}_2\text{COCH}_3$
  - $\text{CH}_3\text{CHO}$
- The hydrocarbon which can react with sodium in liquid ammonia is [2008]
  - $\text{CH}_3\text{CH}_2\text{CH}_2\text{C}\equiv\text{CCH}_2\text{CH}_2\text{CH}_3$
  - $\text{CH}_3\text{CH}_2\text{C}\equiv\text{CH}$
  - $\text{CH}_3\text{CH}=\text{CHCH}_3$
  - $\text{CH}_3\text{CH}_2\text{C}\equiv\text{CCH}_2\text{CH}_3$
- The treatment of  $\text{CH}_3\text{MgX}$  with  $\text{CH}_3\text{C}\equiv\text{C}-\text{H}$  produces [2008]
  - $\text{CH}_3-\text{CH}=\text{CH}_2$
  - $\text{CH}_3\text{C}\equiv\text{C}-\text{CH}_3$
  - $\text{CH}_3-\overset{\text{H}}{\underset{|}{\text{C}}}=\overset{\text{H}}{\underset{|}{\text{C}}}-\text{CH}_3$
  - $\text{CH}_4$
- One mole of a symmetrical alkene on ozonolysis gives two moles of an aldehyde having a molecular mass of 44 u. The alkene is [2010]
  - propene
  - 1-butene
  - 2-butene
  - ethene

18. Ozonolysis of an organic compound gives formaldehyde as one of the products. This confirms the presence of :

[2011]

- (a) two ethylenic double bonds
- (b) a vinyl group
- (c) an isopropyl group
- (d) an acetylenic triple bond

19. Which branched chain isomer of the hydrocarbon with molecular mass 72u gives only one isomer of mono substituted alkyl halide ?

[2012]

- (a) Tertiary butyl chloride
- (b) Neopentane
- (c) Isohexane
- (d) Neohexane

20. 2-Hexyne gives *trans*-2-Hexene on treatment with :

- (a)  $\text{Pt}/\text{H}_2$
- (b)  $\text{Li}/\text{NH}_3$
- (c)  $\text{Pd}/\text{BaSO}_4$
- (d)  $\text{LiAlH}_4$

[2012]

21. Which compound would give 5 - keto - 2 - methylhexanal upon ozonolysis ?

[JEE M 2015]

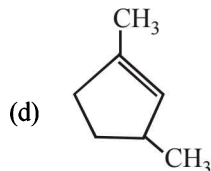
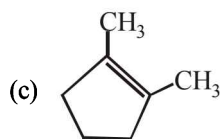
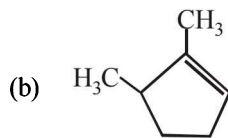
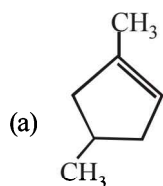

22. The hottest region of Bunsen flame shown in the figure below is :

[JEE M 2016]

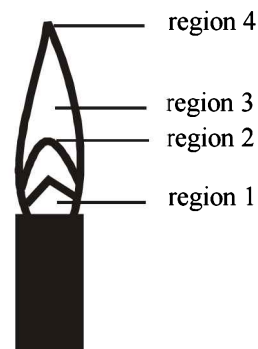

- (a) region 3
- (b) region 4
- (c) region 1
- (d) region 2

23. At 300 K and 1 atm, 15 mL of a gaseous hydrocarbon requires 375 mL air containing 20%  $\text{O}_2$  by volume for complete combustion. After combustion the gases occupy 330 mL. Assuming that the water formed is in liquid form and the volumes were measured at the same temperature and pressure, the formula of the hydrocarbon is:

[JEE M 2016]

- (a)  $\text{C}_4\text{H}_8$
- (b)  $\text{C}_4\text{H}_{10}$
- (c)  $\text{C}_3\text{H}_6$
- (d)  $\text{C}_3\text{H}_8$

24. The reaction of propene with  $\text{HOCl}$  ( $\text{Cl}_2 + \text{H}_2\text{O}$ ) proceeds through the intermediate:

[JEE M 2016]

- (a)  $\text{CH}_3 - \text{CH}(\text{OH}) - \text{CH}_2^+$
- (b)  $\text{CH}_3 - \text{CHCl} - \text{CH}_2^+$
- (c)  $\text{CH}_3 - \text{CH}^+ - \text{CH}_2 - \text{OH}$
- (d)  $\text{CH}_3 - \text{CH}^+ - \text{CH}_2 - \text{Cl}$

## CHAPTER

## 11

## The Solid State &amp; Surface Chemistry

## Section-A JEE Advanced/ IIT-JEE

## C MCQs with One Correct Answer

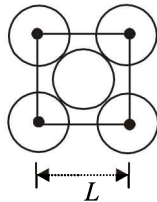
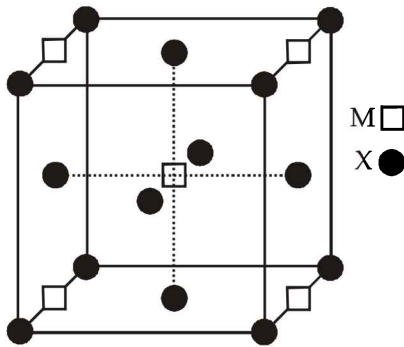
- CsBr has bcc structure with edge length 4.3. The shortest inter ionic distance in between  $\text{Cs}^+$  and  $\text{Br}^-$  is : (1995S)
  - 3.72
  - 1.86
  - 7.44
  - 4.3
- The coordination number of a metal crystallizing in a hexagonal close-packed structure is (1999 - 2 Marks)
  - 12
  - 4
  - 8
  - 6
- In a solid 'AB' having the NaCl structure, 'A' atoms occupy the corners of the cubic unit cell. If all the face-centered atoms along one of the axes are removed, then the resultant stoichiometry of the solid is (2001S)
  - $\text{AB}_2$
  - $\text{A}_2\text{B}$
  - $\text{A}_4\text{B}_3$
  - $\text{A}_3\text{B}_4$
- A substance  $\text{A}_x\text{B}_y$  crystallizes in a face centred cubic (FCC) lattice in which atoms 'A' occupy each corner of the cube and atoms 'B' occupy the centres of each face of the cube. Identify the correct composition of the substance  $\text{A}_x\text{B}_y$ 
  - $\text{AB}_3$
  - $\text{A}_4\text{B}_3$
  - $\text{A}_3\text{B}$
  - Composition cannot be specified
- Rate of physisorption increases with (2003S)
  - decrease in temperature
  - increase in temperature
  - decrease in pressure
  - decrease in surface area
- Adsorption of gases on solid surface is generally exothermic because (2004S)
  - enthalpy is positive
  - entropy decreases
  - entropy increases
  - free energy increases
- In which of the following crystals alternate tetrahedral voids are occupied? (2005S)
  - NaCl
  - ZnS
  - $\text{CaF}_2$
  - $\text{Na}_2\text{O}$
- Lyophilic sols are (2005S)
  - Irreversible sols
  - They are prepared from inorganic compound
  - Coagulated by adding electrolytes
  - Self-stabilizing
- Among the following, the surfactant that will form micelles in aqueous solution at the lowest molar concentration at ambient condition is : - (2008S)
  - $\text{CH}_3(\text{CH}_2)_{15}\text{N}^+(\text{CH}_3)_3\text{Br}^-$
  - $\text{CH}_3(\text{CH}_2)_{11}\text{OSO}_3^-\text{Na}^+$
  - $\text{CH}_3(\text{CH}_2)_6\text{COO}^-\text{Na}^+$
  - $\text{CH}_3(\text{CH}_2)_{11}\text{N}^+(\text{CH}_3)_3\text{Br}^-$
- Among the electrolytes  $\text{Na}_2\text{SO}_4$ ,  $\text{CaCl}_2$ ,  $\text{Al}_2(\text{SO}_4)_3$  and  $\text{NH}_4\text{Cl}$ , the most effective coagulating agent for  $\text{Sb}_2\text{S}_3$  sol is (2009S)
  - $\text{Na}_2\text{SO}_4$
  - $\text{CaCl}_2$
  - $\text{Al}_2(\text{SO}_4)_3$
  - $\text{NH}_4\text{Cl}$
- The packing efficiency of the two-dimensional square unit cell shown below is : (2010)
 
  - 39.27%
  - 68.02%
  - 74.05%
  - 78.54%
- A compound  $\text{M}_p\text{X}_q$  has cubic close packing (ccp) arrangement of X. Its unit cell structure is shown below. The empirical formula of the compound is (2012 - I)
 
  - $\text{MX}$
  - $\text{MX}_2$
  - $\text{M}_2\text{X}$
  - $\text{M}_5\text{X}_{14}$

13. The arrangement of  $X^-$  ions around  $A^+$  ion in solid AX is given in the figure (not drawn to scale). If the radius of  $X^-$  is 250 pm, the radius of  $A^+$  is (JEE Adv. 2013)

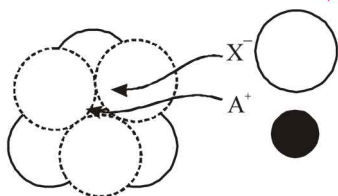

- (a) 104 pm (c) 183 pm (b) 125 pm (d) 57 pm
14. Methylene blue, from its aqueous solution, is adsorbed on activated charcoal at 25°C. For this process, the correct statement is (JEE Adv. 2013)
- (a) The adsorption requires activation at 25°C  
 (b) The adsorption is accompanied by a decrease in enthalpy  
 (c) The adsorption increases with increase of temperature  
 (d) The adsorption is irreversible

### D MCQs with One or More Than One Correct

1. Which of the following statement(s) is (are) correct? (1998 - 2 Marks)
- (a) The coordination number of each type of ion in CsCl crystal is 8.  
 (b) A metal that crystallizes in bcc structure has a coordination number of 12.  
 (c) A unit cell of an ionic crystal shares some of its ions with other unit cells.  
 (d) The length of the unit cell in NaCl is 552 pm. ( $r_{Na^+} = 95$  pm;  $r_{Cl^-} = 181$  pm).
2. The correct statement(s) regarding defects in solids is (are) (2009S)
- (a) Frenkel defect is usually favoured by a very small difference in the sizes of cation and anion  
 (b) Frenkel defect is a dislocation defect  
 (c) Trapping of an electron in the lattice leads to the formation of F-centre  
 (d) Schottky defects have no effect on the physical properties of solids
3. The correct statement(s) pertaining to the adsorption of a gas on a solid surface is (are) (2011)
- (a) Adsorption is always exothermic  
 (b) Physisorption may transform into chemisorption at high temperature  
 (c) Physisorption increases with increasing temperature but chemisorption decreases with increasing temperature  
 (d) Chemisorption is more exothermic than physisorption, however it is very slow due to higher energy of activation
4. Choose the correct reason(s) for the stability of the **lyophobic** colloidal particles. (2012)
- (a) Preferential adsorption of ions on their surface from the solution.  
 (b) Preferential adsorption of solvent on their surface from the solution.  
 (c) Attraction between different particles having opposite charges on their surface.

- (d) Potential difference between the fixed layer and the diffused layer of opposite charges around the colloidal particles.

5. The given graphs/data I, II, III and IV represent general trends observed for different physisorption and chemisorption processes under mild conditions of temperature and pressure. Which of the following choice(s) about I, II, III and IV is (are) correct? (2012)

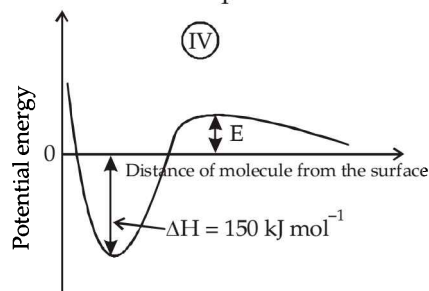
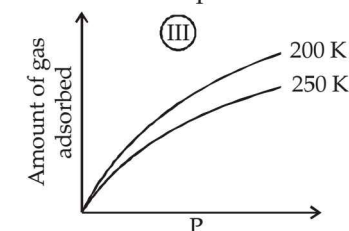
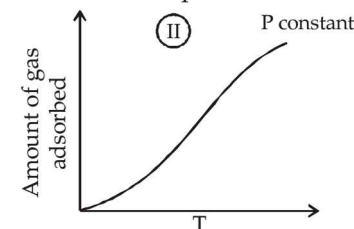
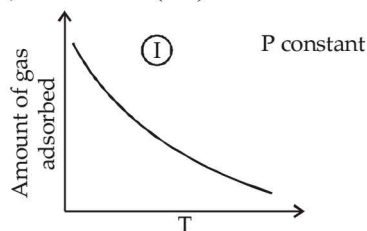

- (a) I is physisorption and II is chemisorption  
 (b) I is physisorption and III is chemisorption  
 (c) IV is chemisorption and II is chemisorption  
 (d) IV is chemisorption and III is chemisorption
6. If the unit cell of a mineral has cubic close packed (ccp) array of oxygen atoms with  $m$  fraction of octahedral holes occupied by aluminium ions and  $n$  fraction of tetrahedral holes occupied by magnesium ions,  $m$  and  $n$ , respectively, are (JEE Adv. 2015)
- (a)  $\frac{1}{2}, \frac{1}{8}$  (b)  $1, \frac{1}{4}$  (c)  $\frac{1}{2}, \frac{1}{2}$  (d)  $\frac{1}{4}, \frac{1}{8}$
7. When  $O_2$  is adsorbed on a metallic surface, electron transfer occurs from the metal to  $O_2$ . The true statement(s) regarding this adsorption is(are) (JEE Adv. 2015)
- (a)  $O_2$  is physisorbed  
 (b) Heat is released  
 (c) Occupancy of  $\pi_{2p}^*$  of  $O_2$  is increased  
 (d) Bond length of  $O_2$  is increased

8. The CORRECT statement(s) for cubic close packed (ccp) three dimensional structure is (are) (JEE Adv. 2016)
- The number of the nearest neighbours of an atom present in the topmost layer is 12
  - The efficiency of atom packing is 74%
  - The number of octahedral and tetrahedral voids per atom are 1 and 2, respectively
  - The unit cell edge length is  $2\sqrt{2}$  times the radius of the atom

### E Subjective Problems

- The density of mercury is 13.6 g/ml. Calculate approximately the diameter of an atom of mercury assuming that each atom is occupying a cube of edge length equal to the diameter of the mercury atom. (1983 - 3 Marks)
  - Sodium metal crystallizes in body centred cubic lattice with the cell edge,  $a = 4.29 \text{ \AA}$ . What is the radius of sodium atom? (1994 - 2 Marks)
  - A metallic element crystallises into a lattice containing a sequence of layers of ABABAB..... Any packing of spheres leaves out voids in the lattice. What percentage by volume of this lattice is empty space? (1996 - 3 Marks)
  - Chromium metal crystallizes with a body centred cubic lattice. The length of the unit cell edge is found to be 287 pm. Calculate the atomic radius. What would be the density of chromium in  $\text{g/cm}^3$ ? (1997 - 3 Marks)
  - A metal crystallises into two cubic phases, face centered cubic (FCC) and body centred cubic (BCC), whose unit cell lengths are 3.5 and 3.0  $\text{ \AA}$ , respectively, Calculate the ratio of densities of FCC and BCC. (1999 - 3 Marks)
  - The figures given below show the location of atoms in three crystallographic planes in a FCC lattice. Draw the unit cell for the corresponding structure and identify these planes in your diagram. (2000 - 3 Marks)
7. You are given marbles of diameter 10 mm. They are to be placed such that their centres are lying in a square bound by four lines each of length 40 mm. What will be the arrangements of marbles in a plane so that maximum number of marbles can be placed inside the area? Sketch the diagram and derive expression for the number of molecules per unit area. (2003 - 2 Marks)
8. 1 gm of charcoal adsorbs 100 ml 0.5 M  $\text{CH}_3\text{COOH}$  to form a monolayer, and thereby the molarity of  $\text{CH}_3\text{COOH}$  reduces to 0.49. Calculate the surface area of the charcoal adsorbed by each molecule of acetic acid. Surface area of charcoal =  $3.01 \times 10^2 \text{ m}^2/\text{gm}$ . (2003 - 2 Marks)
9. A compound AB has rock salt type structure. The formula weight of AB is 6.023 Y amu, and the closest A - B distance is  $Y^{1/3} \text{ nm}$ , where Y is an arbitrary number. (2004 - 2 Marks)
- Find the density of lattice
  - If the density of lattice is found to be  $20 \text{ kg m}^{-3}$ , then predict the type of defect.
10. In face centred cubic (fcc) crystal lattice, edge length is 400 pm. Find the diameter of greatest sphere which can be fit into the interstitial void without distortion of lattice. (2005 - 2 Marks)
11. 20% of surface sites are occupied by  $\text{N}_2$  molecules. The density of surface site is  $6.023 \times 10^{14} \text{ cm}^{-2}$  and total surface area is  $1000 \text{ cm}^2$ . The catalyst is heated to 300 K while  $\text{N}_2$  is completely desorbed into a pressure of 0.001 atm and volume of  $2.46 \text{ cm}^3$ . Find the number of active sites occupied by each  $\text{N}_2$  molecule. (2005 - 4 Marks)
12. The edge length of unit cell of a metal having molecular weight 75 g/mol is  $5 \text{ \AA}$  which crystallizes in cubic lattice. If the density is 2 g/cc then find the radius of metal atom ( $N_A = 6 \times 10^{23}$ ). Give the answer in pm. (2006 - 6M)

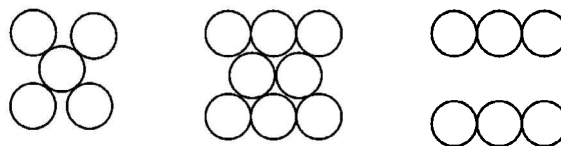

### F Match the Following

Each question contains statements given in two columns, which have to be matched. The statements in Column-I are labelled A, B, C and D, while the statements in Column-II are labelled p, q, r, s and t. Any given statement in Column-I can have correct matching with ONE OR MORE statement(s) in Column-II. The appropriate bubbles corresponding to the answers to these questions have to be darkened as illustrated in the following example :

If the correct matches are A-p, s and t; B-q and r; C-p and q; and D-s then the correct darkening of bubbles will look like the given.

	p	q	r	s	t
A	<input checked="" type="checkbox"/>	<input checked="" type="checkbox"/>	<input type="checkbox"/>	<input checked="" type="checkbox"/>	<input checked="" type="checkbox"/>
B	<input type="checkbox"/>	<input checked="" type="checkbox"/>	<input checked="" type="checkbox"/>	<input type="checkbox"/>	<input type="checkbox"/>
C	<input checked="" type="checkbox"/>	<input checked="" type="checkbox"/>	<input type="checkbox"/>	<input type="checkbox"/>	<input type="checkbox"/>
D	<input type="checkbox"/>	<input type="checkbox"/>	<input type="checkbox"/>	<input checked="" type="checkbox"/>	<input type="checkbox"/>

1. Match the crystal system/unit cells mentioned in Column I with their characteristic features mentioned in Column II. Indicate your answer by darkening the appropriate bubbles of the  $4 \times 4$  matrix given in the ORS. (2007)

#### Column I

- Simple cubic and face-centered cubic parameters
- cubic and rhombohedral
- cubic and tetragonal
- hexagonal and monoclinic

#### Column II

- have these parameters,  $a = b = c$  and  $\alpha = \beta = \gamma$
- are two crystal systems
- have only two crystallo-graphic angles of  $90^\circ$
- belong to same crystal system

## G Comprehension Based Questions

### PASSAGE

In hexagonal systems of crystals, a frequently encountered arrangement of atoms is described as a hexagonal prism. Here, the top and bottom of the cell are regular hexagons and three atoms are sandwiched in between them. A space-filling model of this structure, called hexagonal close-packed (HCP), is constituted of a sphere on a flat surface surrounded in the same plane by six identical spheres as closely as possible. There spheres are then placed over the first layer so that they touch each other and represent the second layer. Each one of these three spheres touches three spheres of the bottom layer. Finally, the second layer is covered with third layer that is identical to the bottom layer in relative position. Assume radius of every sphere to be 'r'.

Answer the following questions -

- The number of atoms in the HCP unit cell is (2008)
    - 4
    - 6
    - 12
    - 17
  - The volume of this HCP unit cell is - (2008)
    - $24\sqrt{2}r^3$
    - $16\sqrt{2}r^3$
    - $12\sqrt{2}r^3$
    - $\frac{64}{3\sqrt{3}}r^3$
- The empty space in this HCP unit cell is (2008)
    - 74%
    - 47.6%
    - 32%
    - 26%

## H Assertion & Reason Type Questions

Read the following statement (Assertion) and explanation (Reason) and answer each question as per the options given below :

- If both *assertion* and *reason* are correct, and *reason* is the correct explanation of the *assertion*.
  - If both *assertion* and *reason* are correct, but *reason* is not the correct explanation of the *assertion*.
  - If *assertion* is correct but *reason* is incorrect.
  - If *assertion* is incorrect but *reason* is correct.
- Assertion :** In any ionic solid [MX] with Schottky defects, the number of positive and negative ions are same.  
**Reason :** Equal number of cation and anion vacancies are present. (201S)
  - Assertion :** Micelles are formed by surfactant molecules above the critical micellar concentration (CMC).  
**Reason :** The conductivity of a solution having surfactant molecules decreases sharply at the CMC. (2007)

## I Integer Value Correct Type

- The number of hexagonal faces that are present in a truncated octahedron is (2011)

## Section-B JEE Main / AIEEE

- The formation of gas at the surface of tungsten due to adsorption is the reaction of order [2002]
  - 0
  - 1
  - 2
  - insufficient data.
- Na and Mg crystallize in BCC and FCC type crystals respectively, then the number of atoms of Na and Mg present in the unit cell of their respective crystal is [2002]
  - 4 and 2
  - 9 and 14
  - 14 and 9
  - 2 and 4.
- How many unit cells are present in a cube-shaped ideal crystal of NaCl of mass 1.00 g ? [2003]  
[Atomic masses : Na = 23, Cl = 35.5]
  - $5.14 \times 10^{21}$  unit cells
  - $1.28 \times 10^{21}$  unit cells
  - $1.71 \times 10^{21}$  unit cells
  - $2.57 \times 10^{21}$  unit cells
- Which one of the following characteristics is **not** correct for physical adsorption ? [2003]
  - Adsorption increases with increase in temperature
  - Adsorption is spontaneous
  - Both enthalpy and entropy of adsorption are negative
  - Adsorption on solids is reversible
- What type of crystal defect is indicated in the diagram below? [2004]
 
$$\begin{array}{ccccccc} \text{Na}^+ & \text{Cl}^- & \text{Na}^+ & \text{Cl}^- & \text{Na}^+ & \text{Cl}^- & \\ \text{Cl}^- & \square & \text{Cl}^- & \text{Na}^+ & \square & \text{Na}^+ & \\ \text{Na}^+ & \text{Cl}^- & \square & \text{Cl}^- & \text{Na}^+ & \text{Cl}^- & \\ \text{Cl}^- & \text{Na}^+ & \text{Cl}^- & \text{Na}^+ & \square & \text{Na}^+ & \end{array}$$
  - Interstitial defect
  - Schottky defect
  - Frenkel defect
  - Frenkel and Schottky defects
- Identify the correct statement regarding enzymes [2004]
  - Enzymes are specific biological catalysts that cannot be poisoned
  - Enzymes are normally heterogeneous catalysts that are very specific in their action
  - Enzymes are specific biological catalysts that can normally function at very high temperatures ( $T \sim 1000\text{K}$ )
  - Enzymes are specific biological catalysts that possess well-defined active sites



7. An ionic compound has a unit cell consisting of A ions at the corners of a cube and B ions on the centres of the faces of the cube. The empirical formula for this compound would be [2005]
- (a)  $A_3B$  (b)  $AB_3$   
(c)  $A_2B$  (d)  $AB$
8. The volume of a colloidal particle,  $V_C$  as compared to the volume of a solute particle in a true solution  $V_S$ , could be [2005]
- (a)  $\frac{V_C}{V_S} \approx 10^3$  (b)  $\frac{V_C}{V_S} \approx 10^{-3}$   
(c)  $\frac{V_C}{V_S} \approx 10^{23}$  (d)  $\frac{V_C}{V_S} \approx 1$
9. The disperse phase in colloidal iron (III) hydroxide and colloidal gold is positively and negatively charged, respectively. Which of the following statements is NOT correct? [2005]
- (a) Coagulation in both sols can be brought about by electrophoresis  
(b) Mixing the sols has no effect  
(c) Sodium sulphate solution causes coagulation in both sols  
(d) Magnesium chloride solution coagulates, the gold sol more readily than the iron (III) hydroxide sol
10. Total volume of atoms present in a face-centred cubic unit cell of a metal is ( $r$  is atomic radius) [2006]
- (a)  $\frac{12}{3}\pi r^3$  (b)  $\frac{16}{3}\pi r^3$   
(c)  $\frac{20}{3}\pi r^3$  (d)  $\frac{24}{3}\pi r^3$
11. In Langmuir's model of adsorption of a gas on a solid surface [2006]
- (a) the mass of gas striking a given area of surface is proportional to the pressure of the gas  
(b) the mass of gas striking a given area of surface is independent of the pressure of the gas  
(c) the rate of dissociation of adsorbed molecules from the surface does not depend on the surface covered  
(d) the adsorption at a single site on the surface may involve multiple molecules at the same time
12. In a compound, atoms of element Y form ccp lattice and those of element X occupy  $2/3^{\text{rd}}$  of tetrahedral voids. The formula of the compound will be [2008]
- (a)  $X_4Y_3$  (b)  $X_2Y_3$   
(c)  $X_2Y$  (d)  $X_3Y_4$
13. Gold numbers of protective colloids A, B, C and D are 0.50, 0.01, 0.10 and 0.005, respectively. the correct order of their protective powers is [2008]
- (a)  $D < A < C < B$  (b)  $C < B < D < A$   
(c)  $A < C < B < D$  (d)  $B < D < A < C$
14. Which of the following statements is incorrect regarding physisorptions? [2009]
- (a) More easily liquefiable gases are adsorbed readily.  
(b) Under high pressure it results into multi molecular layer on adsorbent surface.  
(c) Enthalpy of adsorption ( $\Delta H_{\text{adsorption}}$ ) is low and positive.  
(d) It occurs because of van der Waal's forces.
15. Copper crystallises in *fcc* with a unit cell length of 361 pm. What is the radius of copper atom? [2009]
- (a) 127 pm (b) 157 pm  
(c) 181 pm (d) 108 pm
16. The edge length of a face centered cubic cell of an ionic substance is 508 pm. If the radius of the cation is 110 pm, the radius of the anion is [2010]
- (a) 288 pm (b) 398 pm  
(c) 618 pm (d) 144 pm
17. Percentages of free space in cubic close packed structure and in body centered packed structure are respectively [2010]
- (a) 30% and 26% (b) 26% and 32%  
(c) 32% and 48% (d) 48% and 26%
18. In a face centred cubic lattice, atom A occupies the corner positions and atom B occupies the face centre positions. If one atom of B is missing from one of the face centred points, the formula of the compound is : [2011]
- (a)  $A_2B$  (b)  $AB_2$   
(c)  $A_2B_3$  (d)  $A_2B_5$
19. Lithium forms body centred cubic structure. The length of the side of its unit cell is 351 pm. Atomic radius of the lithium will be : [2012]
- (a) 75 pm (b) 300 pm  
(c) 240 pm (d) 152 pm
20. According to Freundlich adsorption isotherm which of the following is correct? [2012]
- (a)  $\frac{x}{m} \propto p^0$   
(b)  $\frac{x}{m} \propto p^1$   
(c)  $\frac{x}{m} \propto p^{1/n}$   
(d) All the above are correct for different ranges of pressure

21. Which of the following exists as covalent crystals in the solid state ? [JEE M 2013]  
 (a) Iodine  
 (b) Silicon  
 (c) Sulphur  
 (d) Phosphorus
22. The coagulating power of electrolytes having ions  $\text{Na}^+$ ,  $\text{Al}^{3+}$  and  $\text{Ba}^{2+}$  for arsenic sulphide sol increases in the order : [JEE M 2013]  
 (a)  $\text{Al}^{3+} < \text{Ba}^{2+} < \text{Na}^+$  (b)  $\text{Na}^+ < \text{Ba}^{2+} < \text{Al}^{3+}$   
 (c)  $\text{Ba}^{2+} < \text{Na}^+ < \text{Al}^{3+}$  (d)  $\text{Al}^{3+} < \text{Na}^+ < \text{Ba}^{2+}$
23. CsCl crystallises in body centred cubic lattice. If 'a' is its edge length then which of the following expressions is correct? [JEE M 2014]  
 (a)  $r_{\text{Cs}^+} + r_{\text{Cl}^-} = 3a$  (b)  $r_{\text{Cs}^+} + r_{\text{Cl}^-} = \frac{3a}{2}$   
 (c)  $r_{\text{Cs}^+} + r_{\text{Cl}^-} = \frac{\sqrt{3}}{2}a$  (d)  $r_{\text{Cs}^+} + r_{\text{Cl}^-} = \sqrt{3}a$
24. Sodium metal crystallizes in a body centred cubic lattice with a unit cell edge of  $4.29\text{\AA}$ . The radius of sodium atom is approximately : [JEE M 2015]  
 (a)  $5.72\text{\AA}$  (b)  $0.93\text{\AA}$   
 (c)  $1.86\text{\AA}$  (d)  $3.22\text{\AA}$
25. 3 g of activated charcoal was added to 50 mL of acetic acid solution (0.06N) in a flask. After an hour it was filtered and the strength of the filtrate was found to be 0.042 N. The amount of acetic acid adsorbed (per gram of charcoal) is : [JEE M 2015]  
 (a) 42 mg (b) 54 mg  
 (c) 18 mg (d) 36 mg
26. For a linear plot of  $\log(x/m)$  versus  $\log p$  in a Freundlich adsorption isotherm, which of the following statements is correct? ( $k$  and  $n$  are constants) [JEE M 2016]  
 (a) Only  $1/n$  appears as the slope.  
 (b)  $\log(1/n)$  appears as the intercept.  
 (c) Both  $k$  and  $1/n$  appear in the slope term.  
 (d)  $1/n$  appears as the intercept.

## CHAPTER

## 12

## Solutions

## Section-A JEE Advanced/ IIT-JEE

## A Fill in the Blanks

1. Given that  $\Delta T_f$  is the depression in freezing point of the solvent in a solution of a non-volatile solute of molality,  $m$ , the quantity  $\lim_{m \rightarrow 0} L t (\Delta T_f / m)$  is equal to ..... (1994 - 1 Mark)

## C MCQs with One Correct Answer

1. An azeotropic solution of two liquids has boiling point lower than either of them when it (1981 - 1 Mark)
- shows negative deviation from Raoult's law
  - shows no deviation from Raoult's law
  - shows positive deviation from Raoult's law
  - is saturated
2. For a dilute solution, Raoult's law states that : (1985 - 1 Mark)
- the lowering of vapour pressure is equal to the mole fraction of solute.
  - the relative lowering of vapour pressure is equal to the mole fraction of solute.
  - the relative lowering of vapour pressure is proportional to the amount of solute in solution.
  - the vapour pressure of the solution is equal to the mole fraction of solvent.
3. When mercuric iodide is added to the aqueous solution of potassium iodide then (1987 - 1 Mark)
- freezing point is raised.
  - freezing point is lowered.
  - freezing point does not change.
  - boiling point does not change.
4. Which of the following 0.1 M aqueous solutions will have the lowest freezing point? (1989 - 1 Mark)
- Potassium sulphate
  - Sodium chloride
  - Urea
  - Glucose
5. The freezing point of equimolal aqueous solutions will be highest for : (1990 - 1 Mark)
- $C_6H_5NH_3Cl$  (aniline hydrochloride)
  - $Ca(NO_3)_2$
  - $La(NO_3)_3$
  - $C_6H_{12}O_6$  (glucose)
6. 0.2 molal acid HX is 20% ionised in solution.  $K_f = 1.86$  K molality<sup>-1</sup>. The freezing point of the solution is : (1995S)
- 0.45
  - 0.90
  - 0.31
  - 0.53
7. The molecular weight of benzoic acid in benzene as determined by depression in freezing point method corresponds to : (1996 - 1 Mark)
- ionization of benzoic acid.
  - dimerization of benzoic acid.
  - trimerization of benzoic acid.
  - solvation of benzoic acid.
8. During depression of freezing point in a solution the following are in equilibrium (2003S)
- liquid solvent, solid solvent
  - liquid solvent, solid solute
  - liquid solute, solid solute
  - liquid solute, solid solvent
9. The elevation in boiling point of a solution of 13.44 g of  $CuCl_2$  in 1 kg of water using the following information will be (Molecular weight of  $CuCl_2 = 134.4$  and  $K_b = 0.52$  K molal<sup>-1</sup>) (2005S)
- 0.16
  - 0.05
  - 0.1
  - 0.2
10. When 20 g of naphthoic acid ( $C_{11}H_8O_2$ ) is dissolved in 50 g of benzene ( $K_f = 1.72$  K kg mol<sup>-1</sup>), a freezing point depression of 2K is observed. The Van't Hoff factor ( $i$ ) is (2007)
- 0.5
  - 1
  - 2
  - 3
11. The Henry's law constant for the solubility of  $N_2$  gas in water at 298 K is  $1.0 \times 10^5$  atm. The mole fraction of  $N_2$  in air is 0.8. The number of moles of  $N_2$  from air dissolved in 10 moles of water at 298 K and 5 atm pressure is (2009)
- $4.0 \times 10^{-4}$
  - $4.0 \times 10^{-5}$
  - $5.0 \times 10^{-4}$
  - $4.0 \times 10^{-6}$
12. Dissolving 120 g of urea (mol. wt. 60) in 1000 g of water gave a solution of density 1.15 g/mL. The molarity of the solution is (2011)
- 1.78 M
  - 2.00 M
  - 2.05 M
  - 2.22 M

13. The freezing point (in °C) of a solution containing 0.1 g of  $K_3[Fe(CN)_6]$  (Mol. wt. 329) in 100 g of water ( $K_f = 1.86 \text{ K kg mol}^{-1}$ ) is (2011)
- (a)  $-2.3 \times 10^{-2}$  (b)  $-5.7 \times 10^{-2}$   
 (c)  $-5.7 \times 10^{-3}$  (d)  $-1.2 \times 10^{-2}$
14. For a dilute solution containing 2.5 g of a non-volatile non-electrolyte solute in 100 g of water, the elevation in boiling point at 1 atm pressure is 2°C. Assuming concentration of solute is much lower than the concentration of solvent, the vapour pressure (mm of Hg) of the solution is (take  $K_b = 0.76 \text{ K kg mol}^{-1}$ ) (2012)
- (a) 724 (b) 740  
 (c) 736 (d) 718

### D MCQs with One or More Than One Correct

1. In the depression of freezing point experiment, it is found that the (1999 - 3 Marks)
- (a) vapour pressure of the solution is less than that of pure solvent  
 (b) vapour pressure of the solution is more than that of pure solvent  
 (c) only solute molecules solidify at the freezing point  
 (d) only solvent molecules solidify at the freezing
2. Benzene and naphthalene form an ideal solution at room temperature. For this process, the true statement(s) is(are) (JEE Adv. 2013)
- (a)  $\Delta G$  is positive (b)  $\Delta S_{\text{system}}$  is positive  
 (c)  $\Delta S_{\text{surroundings}} = 0$  (d)  $\Delta H = 0$
3. Mixture(s) showing positive deviation from Raoult's law at 35°C is (are) (JEE Adv. 2016)
- (a) carbon tetrachloride + methanol  
 (b) carbon disulphide + acetone  
 (c) benzene + toluene  
 (d) phenol + aniline
4. The vapour pressure of pure benzene is 639.7 mm of mercury and the vapour of a solution of a solute in benzene at the same temperature is 631.9 mm of mercury. Calculate the molality of the solution. (1981 - 3 Marks)
5. An organic compound  $C_xH_yO_z$  was burnt with twice the amount of oxygen needed for complete combustion to  $CO_2$  and  $H_2O$ . The hot gases when cooled to 0°C and 1 atm. pressure, measured 2.24 liters. The water collected during cooling weighed 0.9 g. The vapour pressure of pure water at 20°C is 17.5 mm Hg and is lowered by 0.104 mm when 50 g of the organic compound are dissolved in 1000 g of water. Give the molecular formula of the organic compound. (1983 - 5 Marks)
6. 'Two volatile and miscible liquids can be separated by fractional distillation into pure component', is true under what conditions? (1984 - 1 Mark)
7. The vapour pressure of ethanol and methanol are 44.5 mm and 88.7 Hg respectively. An ideal solution is formed at the same temperature by mixing 60 g of ethanol with 40 g of methanol. Calculate the total vapour pressure of the solution and the mole fraction of methanol in the vapour. (1986 - 4 Marks)
8. The vapour pressure of a dilute aqueous solution of glucose ( $C_6H_{12}O_6$ ) is 750 mm of mercury at 373 K. Calculate (i) molality and (ii) mole fraction of the solution. (1989 - 3 Marks)
9. The vapour pressure of pure benzene at a certain temperature is 640 mm Hg. A non-volatile non-electrolyte solid weighing 2.175 g is added to 39.0 g of benzene. The vapour pressure of the solution is 600 mm Hg. What is the molecular weight of the solid substance? (1990 - 3 Marks)
10. The degree of dissociation of calcium nitrate in a dilute aqueous solution, containing 7.0 g. of the salt per 100 gm of water at 100°C is 70%. If the vapour pressure of water at 100°C is 760 mm, calculate the vapour pressure of the solution. (1991 - 4 Marks)
11. Addition of 0.643 g of a compound to 50 ml. of benzene (density : 0.879 g/ml.) lowers the freezing point from 5.51°C to 5.03°C. If  $K_f$  for benzene is 5.12 K kg mol<sup>-1</sup>, calculate the molecular weight of the compound. (1992 - 2 Marks)
12. What weight of the non-volatile solute, urea ( $NH_2 - CO - NH_2$ ) needs to be dissolved in 100g of water, in order to decrease the vapour pressure of water by 25%? What will be the molality of the solution? (1993 - 3 Marks)
13. The molar volume of liquid benzene (density=0.877 g mL<sup>-1</sup>) increases by a factor of 2750 as it vaporises at 20°C and that of liquid toluene (density=0.867 g mL<sup>-1</sup>) increases by a factor of 7720 at 20°C. A solution of benzene and toluene at 20°C has a vapour pressure of 46.0 Torr. Find the mole fraction of benzene in the vapour above the solution. (1996 - 3 Marks)
14. A solution of a nonvolatile solute in water freezes at -0.30°C. The vapour pressure of pure water at 298 K is 23.51 mm Hg and  $K_f$  for water is 1.86 K kg mol<sup>-1</sup>. Calculate the vapour pressure of this solution at 298 K. (1998 - 4 Marks)

### E Subjective Problems

1. What is the molarity and molality of a 13% solution (by weight) of sulphuric acid with a density of 1.02 g/ml? To what volume should 100 ml of this acid be diluted in order to prepare a 1.5 N solution? (1978)
2. A bottle of commercial sulphuric acid (density 1.787 g/ml) is labelled as 86 percent by weight. What is the molarity of the acid. What volume of the acid has to be used to make 1 litre of 0.2 M  $H_2SO_4$ ? (1979)
3. 0.5 gm of fuming  $H_2SO_4$  (Oleum) is diluted with water. This solution is completely neutralized by 26.7 ml of 0.4 N NaOH. Find the percentage of free  $SO_3$  in the sample of oleum. (1980)

## Solutions

15. Nitrobenzene is formed as the major product along with a minor product in the reaction of benzene with a hot mixture of nitric acid and sulphuric acid. The minor product consists of carbon : 42.86%, hydrogen : 2.40%, nitrogen : 16.67%, and oxygen: 38.07% (i) Calculate the empirical formula of the minor product. (ii) When 5.5 g of the minor product is dissolved in 45 g of benzene, the boiling point of the solution is 1.84 °C higher than that of pure benzene. Calculate the molar mass of the minor product and determine its molecular and structural formula. (Molal boiling point elevation constant of benzene is 2.53 K kg mol<sup>-1</sup>.) (1999 - 10 Marks)
16. To 500 cm<sup>3</sup> of water, 3.0 × 10<sup>-3</sup> kg of acetic acid is added. If 23% of acetic acid is dissociated, what will be the depression in freezing point? K<sub>f</sub> and density of water are 1.86 K kg<sup>-1</sup> mol<sup>-1</sup> and 0.997 g cm<sup>-3</sup>, respectively. (2000 - 3 Marks)
17. 1.22g of benzoic acid is dissolved in 100 g of acetone and 100 g of benzene separately. Boiling point of the solution in acetone increases by 0.17° C, while that in the benzene increases by 0.13° C; K<sub>b</sub> for acetone and benzene is 1.7 K kg mol<sup>-1</sup> and 2.6 K kg mol<sup>-1</sup>. Find molecular weight of benzoic acid in two cases and justify your answer. (2004 - 2 Marks)
18. 75.2 g of C<sub>6</sub>H<sub>5</sub>OH (phenol) is dissolved in a solvent of K<sub>f</sub> = 14. If the depression in freezing point is 7 K then find the % of phenol that dimerises. (2006 - 6M)

### G Comprehension Based Questions

#### PASSAGE

Properties such as boiling point, freezing point and vapour pressure of a pure solvent change when solute molecules are added to get homogeneous solution. These are called colligative properties. Application of colligative properties are very useful in day-to-day life. One of its example is the use of ethylene glycol and water mixture as anti-freezing liquid in the radiator of automobiles.

A solution M is prepared by mixing ethanol and water. The mole fraction of ethanol in the mixture is 0.9

Given : Freezing point depression constant of water (K<sub>f</sub><sup>water</sup>)  
= 1.86 K kg mol<sup>-1</sup>

Freezing point depression constant of ethanol (K<sub>f</sub><sup>ethanol</sup>)  
= 2.0 K kg mol<sup>-1</sup>

Boiling point elevation constant of water (K<sub>b</sub><sup>water</sup>)  
= 0.52 K kg mol<sup>-1</sup>

Boiling point elevation constant of ethanol (K<sub>b</sub><sup>ethanol</sup>)  
= 1.2 K kg mol<sup>-1</sup>

Standard freezing point of water = 273 K

Standard boiling point of water = 155.7 K

Standard boiling point of water = 373 K

Standard boiling point of ethanol = 351.5 K

Vapour pressure of pure water = 32.8 mm Hg

Vapour pressure of pure ethanol = 40 mm Hg

Molecular weight of water = 18 g mol<sup>-1</sup>

Molecular weight of ethanol = 46 g mol<sup>-1</sup>

**In answering the following questions, consider the solution to be ideal dilute solutions and solutes to be non-volatile and non-dissociative.**

- The freezing point of the solution M is (2008 - 3 Marks)
  - 268.7K
  - 268.5K
  - 234.2K
  - 150.9K
- The vapour pressure of the solution M is (2008 - 3 Marks)
  - 39.3 mm Hg
  - 36.0 mm Hg
  - 29.5 mm Hg
  - 28.8 mm Hg
- Water is added to the solution M such that the mole fraction of water in the solution becomes 0.9. The boiling point of this solution is (2008 - 3 Marks)
  - 380.4K
  - 376.2K
  - 375.5K
  - 354.7K

### I Integer Value Correct Type

- 29.2% (w/w) HCl stock solution has a density of 1.25 g mL<sup>-1</sup>. The molecular weight of HCl is 36.5 g mol<sup>-1</sup>. The volume (mL) of stock solution required to prepare a 200 mL solution of 0.4 M HCl is : (2012)
- MX<sub>2</sub> dissociates into M<sup>2+</sup> and X<sup>-</sup> ions in an aqueous solution, with a degree of dissociation (α) of 0.5. The ratio of the observed depression of freezing point of the aqueous solution to the value of the depression of freezing point in the absence of ionic dissociation is (JEE Adv. 2014)
- A compound H<sub>2</sub>X with molar weight of 80g is dissolved in a solvent having density of 0.4 g ml<sup>-1</sup>. Assuming no change in volume upon dissolution, the molality of a 3.2 molar solution is (JEE Adv. 2014)
- If the freezing point of a 0.01 molal aqueous solution of a cobalt(III) chloride-ammonia complex (which behaves as a strong electrolyte) is -0.0558°C, the number of chloride(s) in the coordination sphere of the complex is [K<sub>f</sub> of water = 1.86 K kg mol<sup>-1</sup>] (JEE Adv. 2015)
- The mole fraction of a solute in a solution is 0.1. At 298 K, molarity of this solution is the same as its molality. Density of this solution at 298 K is 2.0 g cm<sup>-3</sup>. The ratio of the molecular weights of the solute and solvent,  $\left(\frac{MW_{\text{solute}}}{MW_{\text{solvent}}}\right)$ , is (JEE Adv. 2016)

## Section-B

## JEE Main / AIEEE

- Freezing point of an aqueous solution is  $(-0.186)^{\circ}\text{C}$ . Elevation of boiling point of the same solution is  $K_b = 0.512^{\circ}\text{C}$ ,  $K_f = 1.86^{\circ}\text{C}$ , find the increase in boiling point.
  - $0.186^{\circ}\text{C}$
  - $0.0512^{\circ}\text{C}$
  - $0.092^{\circ}\text{C}$
  - $0.2372^{\circ}\text{C}$
- In mixture *A* and *B* components show -ve deviation as
  - $\Delta V_{\text{mix}} > 0$
  - $\Delta H_{\text{mix}} < 0$
  - A* - *B* interaction is weaker than *A* - *A* and *B* - *B* interaction
  - A* - *B* interaction is stronger than *A* - *A* and *B* - *B* interaction.
- If liquids *A* and *B* form an ideal solution
  - the entropy of mixing is zero
  - the free energy of mixing is zero
  - the free energy as well as the entropy of mixing are each zero
  - the enthalpy of mixing is zero
- In a 0.2 molal aqueous solution of a weak acid *HX* the degree of ionization is 0.3. Taking  $k_f$  for water as 1.85, the freezing point of the solution will be nearest to
  - $-0.360^{\circ}\text{C}$
  - $-0.260^{\circ}\text{C}$
  - $+0.480^{\circ}\text{C}$
  - $-0.480^{\circ}\text{C}$
- A pressure cooker reduces cooking time for food because
  - boiling point of water involved in cooking is increased
  - the higher pressure inside the cooker crushes the food material
  - cooking involves chemical changes helped by a rise in temperature
  - heat is more evenly distributed in the cooking space
- Which one of the following aqueous solutions will exhibit highest boiling point?
  - 0.015 M urea
  - 0.01 M  $\text{KNO}_3$
  - 0.01 M  $\text{Na}_2\text{SO}_4$
  - 0.015 M glucose
- For which of the following parameters the structural isomers  $\text{C}_2\text{H}_5\text{OH}$  and  $\text{CH}_3\text{OCH}_3$  would be expected to have the same values?(Assume ideal behaviour)
  - Boiling points
  - Vapour pressure at the same temperature
  - Heat of vaporization
  - Gaseous densities at the same temperature and pressure
- Which of the following liquid pairs shows a positive deviation from Raoult's law?
  - Water - nitric acid
  - Benzene - methanol
  - Water - hydrochloric acid
  - Acetone - chloroform
- Which one of the following statements is FALSE?
  - The correct order of osmotic pressure for 0.01 M aqueous solution of each compound is  $\text{BaCl}_2 > \text{KCl} > \text{CH}_3\text{COOH} > \text{sucrose}$
  - The osmotic pressure ( $\pi$ ) of a solution is given by the equation  $\pi = MRT$ , where *M* is the molarity of the solution
  - Raoult's law states that the vapour pressure of a component over a solution is proportional to its mole fraction
  - Two sucrose solutions of same molality prepared in different solvents will have the same freezing point depression
- Benzene and toluene form nearly ideal solution. At  $20^{\circ}\text{C}$ , the vapour pressure of benzene is 75 torr and that of toluene is 22 torr. The partial vapour pressure of benzene at  $20^{\circ}\text{C}$  for a solution containing 78 g of benzene and 46 g of toluene in torr is
  - 53.5
  - 37.5
  - 25
  - 50
- Equimolar solutions in the same solvent have
  - Different boiling and different freezing points
  - Same boiling and same freezing points
  - Same freezing point but different boiling points
  - Same boiling point but different freezing points
- Among the following mixtures, dipole-dipole as the major interaction, is present in
  - KCl and water
  - benzene and carbon tetrachloride
  - benzene and ethanol
  - acetonitrile and acetone
- 18 g of glucose ( $\text{C}_6\text{H}_{12}\text{O}_6$ ) is added to 178.2 g of water. The vapour pressure of water for this aqueous solution at  $100^{\circ}\text{C}$  is
  - 76.00 Torr
  - 752.40 Torr
  - 759.00 Torr
  - 7.60 Torr

14. A mixture of ethyl alcohol and propyl alcohol has a vapour pressure of 290 mm at 300 K. The vapour pressure of propyl alcohol is 200 mm. If the mole fraction of ethyl alcohol is 0.6, its vapour pressure (in mm) at the same temperature will be [2007]
- (a) 360 (b) 350  
(c) 300 (d) 700
15. Equal masses of methane and oxygen are mixed in an empty container at 25°C. The fraction of the total pressure exerted by oxygen is [2007]
- (a) 1/2 (b) 2/3  
(c)  $\frac{1}{3} \times \frac{273}{298}$  (d) 1/3.
16. A 5.25% solution of a substance is isotonic with a 1.5% solution of urea (molar mass = 60 g mol<sup>-1</sup>) in the same solvent. If the densities of both the solutions are assumed to be equal to 1.0 g cm<sup>-3</sup>, molar mass of the substance will be [2007]
- (a) 210.0 g mol<sup>-1</sup> (b) 90.0 g mol<sup>-1</sup>  
(c) 115.0 g mol<sup>-1</sup> (d) 105.0 g mol<sup>-1</sup>.
17. At 80° C, the vapour pressure of pure liquid 'A' is 520 mm Hg and that of pure liquid 'B' is 1000 mm Hg. If a mixture solution of 'A' and 'B' boils at 80° C and 1 atm pressure, the amount of 'A' in the mixture is (1 atm = 760 mm Hg) [2008]
- (a) 52 mol percent (b) 34 mol percent  
(c) 48 mol percent (d) 50 mol percent
18. The vapour pressure of water at 20° C is 17.5 mm Hg. If 18 g of glucose (C<sub>6</sub>H<sub>12</sub>O<sub>6</sub>) is added to 178.2 g of water at 20° C, the vapour pressure of the resulting solution will be [2008]
- (a) 17.325 mm Hg (b) 15.750 mm Hg  
(c) 16.500 mm Hg (d) 17.500 mm Hg
19. A binary liquid solution is prepared by mixing *n*-heptane and ethanol. Which one of the following statements is correct regarding the behaviour of the solution? [2009]
- (a) The solution is non-ideal, showing -ve deviation from Raoult's Law.  
(b) The solution is non-ideal, showing +ve deviation from Raoult's Law.  
(c) *n*-heptane shows +ve deviation while ethanol shows -ve deviation from Raoult's Law.  
(d) The solution formed is an ideal solution.
20. Two liquids *X* and *Y* form an ideal solution. At 300 K, vapour pressure of the solution containing 1 mol of *X* and 3 mol of *Y* is 550 mmHg. At the same temperature, if 1 mol of *Y* is further added to this solution, vapour pressure of the solution increases by 10 mmHg. Vapour pressure (in mmHg) of *X* and *Y* in their pure states will be, respectively: [2009]
- (a) 300 and 400 (b) 400 and 600  
(c) 500 and 600 (d) 200 and 300
21. If sodium sulphate is considered to be completely dissociated into cations and anions in aqueous solution, the change in freezing point of water ( $\Delta T_f$ ), when 0.01 mol of sodium sulphate is dissolved in 1 kg of water, is ( $K_f = 1.86 \text{ K kg mol}^{-1}$ ) [2010]
- (a) 0.372 K (b) 0.0558 K  
(c) 0.0744 K (d) 0.0186 K
22. On mixing, heptane and octane form an ideal solution. At 373 K, the vapour pressures of the two liquid components (heptane and octane) are 105 kPa and 45 kPa respectively. Vapour pressure of the solution obtained by mixing 25.0 g of heptane and 35 g of octane will be (molar mass of heptane = 100 g mol<sup>-1</sup> and of octane = 114 g mol<sup>-1</sup>) [2010]
- (a) 72.0 kPa (b) 36.1 kPa  
(c) 96.2 kPa (d) 144.5 kPa
23. A 5.2 molal aqueous solution of methyl alcohol, CH<sub>3</sub>OH, is supplied. What is the mole fraction of methyl alcohol in the solution? [2011]
- (a) 0.100 (b) 0.190  
(c) 0.086 (d) 0.050
24. Ethylene glycol is used as an antifreeze in a cold climate. Mass of ethylene glycol which should be added to 4 kg of water to prevent it from freezing at -6°C will be : ( $K_f$  for water = 1.86 K kg mol<sup>-1</sup>, and molar mass of ethylene glycol = 62 g mol<sup>-1</sup>) [2011]
- (a) 804.32 g (b) 204.30 g  
(c) 400.00 g (d) 304.60 g
25. The degree of dissociation ( $\alpha$ ) of a weak electrolyte, A<sub>x</sub>B<sub>y</sub>, is related to van't Hoff factor (*i*) by the expression [2011]
- (a)  $\alpha = \frac{i-1}{(x+y-1)}$  (b)  $\alpha = \frac{i-1}{x+y+1}$   
(c)  $\alpha = \frac{x+y-1}{i-1}$  (d)  $\alpha = \frac{x+y+1}{i-1}$
26. The density of a solution prepared by dissolving 120 g of urea (mol. mass = 60 u) in 1000 g of water is 1.15 g/mL. The molarity of this solution is : [2012]
- (a) 0.50 M (b) 1.78 M  
(c) 1.02 M (d) 2.05 M
27.  $K_f$  for water is 1.86 K kg mol<sup>-1</sup>. If your automobile radiator holds 1.0 kg of water, how many grams of ethylene glycol (C<sub>2</sub>H<sub>6</sub>O<sub>2</sub>) must you add to get the freezing point of the solution lowered to -2.8°C ? [2012]
- (a) 72 g (b) 93 g  
(c) 39 g (d) 27 g

28. The molarity of a solution obtained by mixing 750 mL of 0.5(M)HCl with 250 mL of 2(M)HCl will be: [JEE M 2013]
- (a) 0.875 M                      (b) 1.00 M  
(c) 1.75 M                        (d) 0.975 M
29. Consider separate solutions of 0.500 M  $C_2H_5OH(aq)$ , 0.100 M  $Mg_3(PO_4)_2(aq)$ , 0.250 M  $KBr(aq)$  and 0.125 M  $Na_3PO_4(aq)$  at 25°C. Which statement is true about these solutions, assuming all salts to be strong electrolytes? [JEE M 2014]
- (a) They all have the same osmotic pressure.  
(b) 0.100 M  $Mg_3(PO_4)_2(aq)$  has the highest osmotic pressure.  
(c) 0.125 M  $Na_3PO_4(aq)$  has the highest osmotic pressure.  
(d) 0.500 M  $C_2H_5OH(aq)$  has the highest osmotic pressure.
30. The vapour pressure of acetone at 20°C is 185 torr. When 1.2 g of a non-volatile substance was dissolved in 100 g of acetone at 20°C, its vapour pressure was 183 torr. The molar mass ( $g\ mol^{-1}$ ) of the substance is : [JEE M 2015]
- (a) 128                              (b) 488  
(c) 32                                (d) 64
31. 18 g glucose ( $C_6H_{12}O_6$ ) is added to 178.2 g water. The vapour pressure of water (in torr) for this aqueous solution is: [JEE M 2016]
- (a) 752.4                            (b) 759.0  
(c) 7.6                                (d) 76.0



## CHAPTER

## 13

## Electrochemistry

## Section-A

## JEE Advanced/ IIT-JEE

## A Fill in the Blanks

- Of the halide ions, \_\_\_\_\_ is the most powerful reducing agent. (1978)
- The more \_\_\_\_\_ the standard reduction potential, the \_\_\_\_\_ is its ability to displace hydrogen from acids. (1986 - 1 Mark)
- The electrical conductivity of a solution of acetic acid will be \_\_\_\_\_ if a solution of sodium hydroxide is added. (1987 - 1 Mark)

## B True / False

- The dependence of electrode potential for the electrode  $M^{n+}/M$  with concentration under STP conditions is given by the expression :  $E = E^\circ + \frac{0.0591}{n} \log_{10}[M^{n+}]$  (1993 - 1 Mark)

## C MCQs with One Correct Answer

- The standard reduction potentials at 298 K for the following half reactions are given against each (1981 - 1 Mark)
 

$Zn^{2+}(aq) + 2e \rightleftharpoons Zn(s)$	-0.762
$Cr^{3+}(aq) + 2e \rightleftharpoons Cr(s)$	-0.740
$2H^+(aq) + 2e \rightleftharpoons H_2(g)$	0.000
$Fe^{3+}(aq) + 2e \rightleftharpoons Fe^{2+}(aq)$	0.770

 which is the strongest reducing agent?
  - Zn(s)
  - Cr(s)
  - $H_2(g)$
  - $Fe^{2+}(aq)$
- Faraday's laws of electrolysis are related to the
  - atomic number of the reactants. (1983 - 1 Mark)
  - atomic number of the anion.
  - equivalent weight of the electrolyte.
  - speed of the cation.
- A solution containing one mole per litre of each  $Cu(NO_3)_2$ ,  $AgNO_3$ ,  $Hg_2(NO_3)_2$ ; is being electrolysed by using inert electrodes. The values of standard electrode potentials in volts (reduction potentials) are : (1984 - 1 Mark)
 

$Ag/Ag^+ = +0.80$ ,	$2Hg/Hg_2^{++} = +0.79$
$Cu/Cu^{++} = +0.34$ ,	$Mg/Mg^{++} = -2.37$

 With increasing voltage, the sequence of deposition of metals on the cathode will be :
  - Ag, Hg, Cu, Mg
  - Mg, Cu, Hg, Ag
  - Ag, Hg, Cu
  - Cu, Hg, Ag
- The electric charge for electrode deposition of one gram equivalent of a substance is : (1984 - 1 Mark)
  - one ampere per second.
  - 96,500 coulombs per second.
  - one ampere for one hour.
  - charge on one mole of electrons.
- The reaction : (1985 - 1 Mark)
 
$$\frac{1}{2} Hg_2(g) + AgCl(s) \rightarrow H^+(aq) + Cl^-(aq) + Ag(s)$$
 occurs in the galvanic cell
  - $Ag | AgCl(s) | KCl(soln) | AgNO_3(soln) | Ag$
  - $Pt | H_2(g) | HCl(soln) | AgNO_3(soln) | Ag$
  - $Pt | H_2(g) | HCl(soln) | AgCl(s) | Ag$
  - $Pt | H_2(g) | KCl(soln) | AgCl(s) | Ag$
- A solution of sodium sulphate in water is electrolysed using inert electrodes. The products at the cathode and anode are respectively (1987 - 1 Mark)
  - $H_2, O_2$
  - $O_2, H_2$
  - $O_2, Na$
  - $O_2, SO_2$
- The standard oxidation potentials,  $E^\circ$ , for the half reactions are as (1988 - 1 Mark)
 
$$Zn = Zn^{2+} + 2e^-; E^\circ = +0.76 V$$

$$Fe = Fe^{2+} + 2e^-; E^\circ = +0.41 V$$
 The EMF for the cell reaction :
 
$$Fe^{2+} + Zn \rightarrow Zn^{2+} + Fe$$
  - 0.35 V
  - +0.35 V
  - +1.17 V
  - 1.17 V
- A dilute aqueous solution of  $Na_2SO_4$  is electrolyzed using platinum electrodes. The products at the anode and cathode are: (1996 - 1 Mark)
  - $O_2, H_2$
  - $S_2O_8^{2-}, Na$
  - $O_2, Na$
  - $S_2O_8^{2-}, H_2$
- The standard reduction potentials of  $Cu^{2+} | Cu$  and  $Cu^{2+} | Cu^+$  are 0.337 V and 0.153 respectively. The standard electrode potential of  $Cu^+ | Cu$  half cell is (1997 - 1 Mark)
  - 0.184 V
  - 0.827 V
  - 0.521 V
  - 0.490 V
- A gas X at 1 atm is bubbled through a solution containing a mixture of  $1 M Y^-$  and  $MZ^-$  at 25°C. If the reduction potential of  $Z > Y > X$ , then, (1999 - 2 Marks)
  - Y will oxidize X and not Z
  - Y will oxidize Z and not X
  - Y will oxidize both X and Z
  - Y will reduce both X and Z

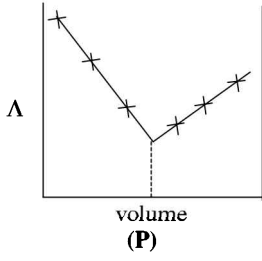
11. For the electrochemical cell,  $M|M^+||X^-|X, E^\circ M^+/M = 0.44V$  and  $E^\circ(X/X^-) = 0.33V$ .  
From this data one can deduce that (2000S)
- $M + X \rightarrow M^+ + X^-$  is the spontaneous reaction
  - $M^+ + X^- \rightarrow M + X$  is the spontaneous reaction
  - $E_{\text{cell}} = 0.77V$
  - $E_{\text{cell}} = -0.77V$
12. Saturated solution of  $KNO_3$  is used to make 'salt-bridge' because (2001S)
- velocity of  $K^+$  is greater than that of  $NO_3^-$
  - velocity of  $NO_3^-$  is greater than that of  $K^+$
  - velocities of both  $K^+$  and  $NO_3^-$  are nearly the same
  - $KNO_3$  is highly soluble in water
13. The correct order of equivalent conductance at infinite dilution of  $LiCl, NaCl$  and  $KCl$  is (2001S)
- $LiCl > NaCl > KCl$
  - $KCl > NaCl > LiCl$
  - $NaCl > KCl > LiCl$
  - $LiCl > KCl > NaCl$
14. Standard electrode potential data are useful for understanding the suitability of an oxidant in a redox titration. Some half cell reactions and their standard potentials are given below: (2002S)
- $$MnO_4^-(aq.) + 8H^+(aq.) + 5e^- \rightarrow Mn^{2+}(aq.) + 4H_2O(l) \quad E^\circ = 1.51V$$
- $$Cr_2O_7^{2-}(aq.) + 14H^+(aq.) + 6e^- \rightarrow 2Cr^{3+}(aq.) + 7H_2O(l) \quad E^\circ = 1.38V$$
- $$Fe^{3+}(aq.) + e^- \rightarrow Fe^{2+}(aq.) \quad E^\circ = 0.77V$$
- $$Cl_2(g) + 2e^- \rightarrow 2Cl^-(aq.) \quad E^\circ = 1.40V$$
- Identify the only incorrect statement regarding the quantitative estimation of aqueous  $Fe(NO_3)_2$
- $MnO_4^-$  can be used in aqueous  $HCl$
  - $Cr_2O_7^{2-}$  can be used in aqueous  $HCl$
  - $MnO_4^-$  can be used in aqueous  $H_2SO_4$
  - $Cr_2O_7^{2-}$  can be used in aqueous  $H_2SO_4$
15. In the electrolytic cell, flow of electrons is from (2003S)
- Cathode to anode in solution
  - Cathode to anode through external supply
  - Cathode to anode through internal supply
  - Anode to cathode through internal supply
16. The emf of the cell (2004S)
- $$Zn|Zn^{2+}(0.01M)||Fe^{2+}(0.001M)|Fe$$
- at 298 K is 0.2905 then the value of equilibrium constant for the cell reaction is
- $e^{\frac{0.32}{0.0295}}$
  - $10^{\frac{0.32}{0.0295}}$
  - $10^{\frac{0.26}{0.0295}}$
  - $10^{\frac{0.32}{0.0591}}$
17. The rusting of iron takes place as follows (2005S)
- $$2H^+ + 2e^- + \frac{1}{2}O_2 \longrightarrow H_2O(l); E^\circ = +1.23V$$
- $$Fe^{2+} + 2e^- \longrightarrow Fe(s); E^\circ = -0.44V$$
- Calculate  $\Delta G^\circ$  for the net process
- $-322 \text{ kJ mol}^{-1}$
  - $-161 \text{ kJ mol}^{-1}$
  - $-152 \text{ kJ mol}^{-1}$
  - $-76 \text{ kJ mol}^{-1}$
18. Electrolysis of dilute aqueous  $NaCl$  solution was carried out by passing 10 milli ampere current. The time required to liberate 0.01 mol of  $H_2$  gas at the cathode is (1 Faraday =  $96500 \text{ C mol}^{-1}$ ) (2008S)
- $9.65 \times 10^4 \text{ sec}$
  - $19.3 \times 10^4 \text{ sec}$
  - $28.95 \times 10^4 \text{ sec}$
  - $38.6 \times 10^4 \text{ sec}$
19.  $AgNO_3(aq.)$  was added to an aqueous  $KCl$  solution gradually and the conductivity of the solution was measured. The plot of conductance ( $\Lambda$ ) versus the volume of  $AgNO_3$  is (2011)
- 

(P)

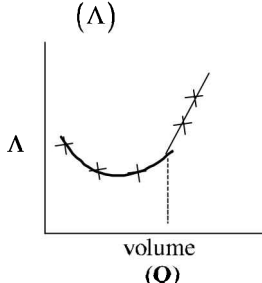

(Q)

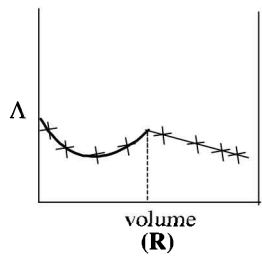

(R)

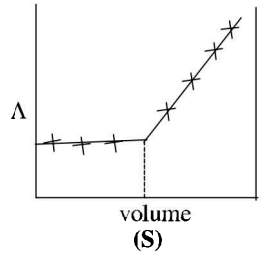

(S)
- (P)
  - (Q)
  - (R)
  - (S)
20. Consider the following cell reaction: (2011)
- $$2Fe_{(s)} + O_{2(g)} + 4H^+_{(aq)} \rightarrow 2Fe^{2+}_{(aq)} + 2H_2O_{(l)}; E^\circ = 1.67V$$
- At  $[Fe^{2+}] = 10^{-3}M$ ,  $P(O_2) = 0.1 \text{ atm}$  and  $pH = 3$ , the cell potential at  $25^\circ C$  is
- 1.47V
  - 1.77V
  - 1.87V
  - 1.57V
21. For the following electrochemical cell at 298 K,  
 $Pt(s)|H_2(g, 1 \text{ bar})|H^+(aq, 1M)||M^{4+}(aq), M^{2+}(aq)|Pt(s)$
- $$E_{\text{cell}} = 0.092V \text{ when } \frac{[M^{2+}(aq)]}{[M^{4+}(aq)]} = 10^x \quad (JEE \text{ Adv. } 2016)$$
- Given:  $E^\circ_{M^{4+}/M^{2+}} = 0.151V$ ;  $2.303 \frac{RT}{F} = 0.059V$
- The value of x is
- 2
  - 1
  - 1
  - 2

**D MCQs with One or More Than One Correct**

- The standard reduction potential values of three metallic cations, X, Y and Z are 0.52, -3.03 and -1.18 V respectively. The order of reducing power of the corresponding metals is (1998 - 2 Marks)
  - $Y > Z > X$
  - $X > Y > Z$
  - $Z > Y > X$
  - $Z > X > Y$
- For the reduction of  $\text{NO}_3^-$  ion in an aqueous solution,  $E^\circ$  is +0.96V. Values of  $E^\circ$  for some metal ions are given below
 

$\text{V}^{2+}(\text{aq}) + 2\text{e}^- \rightarrow \text{V}$	$E^\circ = -1.19 \text{ V}$
$\text{Fe}^{3+}(\text{aq}) + 3\text{e}^- \rightarrow \text{Fe}$	$E^\circ = -0.04 \text{ V}$
$\text{Au}^{3+}(\text{aq}) + 3\text{e}^- \rightarrow \text{Au}$	$E^\circ = +1.40 \text{ V}$
$\text{Hg}^{2+}(\text{aq}) + 2\text{e}^- \rightarrow \text{Hg}$	$E^\circ = +0.86 \text{ V}$

 The pair(s) of metals that is(are) oxidized by  $\text{NO}_3^-$  in aqueous solution is(are) (2009)
  - V and Hg
  - Hg and Fe
  - Fe and Au
  - Fe and V
- In a galvanic cell, the salt bridge (JEE Adv. 2014)
  - Does not participate chemically in the cell reaction
  - Stops the diffusion of ions from one electrode to another
  - Is necessary for the occurrence of the cell reaction
  - Ensures mixing of the two electrolytic solutions

**E Subjective Problems**

- The density of copper is 8.94 g/ml. Find out the number of coulombs needed to plate an area  $10 \text{ cm} \times 10 \text{ cm}$  to a thickness  $10^{-2} \text{ cm}$  using  $\text{CuSO}_4$  solution as electrolyte. (1979)
- 19 gm of molten  $\text{SnCl}_2$  is electrolysed for some time. Inert electrodes are used. 0.119 gm of Sn is deposited at the cathode. No substance is lost during the electrolysis. Find the ratio of the weights of  $\text{SnCl}_2$ :  $\text{SnCl}_4$  after electrolysis.
  - A hot solution of NaCl in water is electrolysed. Iron electrodes are used. Diaphragm cell is not used. Give equations for all the chemical reactions that take place during electrolysis.
  - Find the charge in coulombs of 1 gram ion of  $\text{N}^{3-}$  (1980)
- Complete and balance the following equations (1980)
  - $\text{KNO}_3 + \text{FeSO}_4 + \text{H}_2\text{SO}_4(\text{conc}) \longrightarrow$
  - $\text{H}_2\text{S} + \text{K}_2\text{CrO}_4 + \text{H}_2\text{SO}_4 \longrightarrow$
  - $\text{KI} + \text{H}_2\text{SO}_4(\text{conc}) \xrightarrow{\Delta}$
  - $\text{Mg}_3\text{N}_2 + \text{H}_2\text{O} \longrightarrow$
  - $\text{Al} + \text{KMnO}_4 + \text{H}_2\text{SO}_4 \longrightarrow$

- Consider the cell (1982 - 2 Marks)
 
$$\text{Zn} | \text{Zn}^{2+}(\text{aq})(1.0 \text{ M}) || \text{Cu}^{2+}(\text{aq})(1.0 \text{ M}) | \text{Cu}$$
 The standard reduction potentials are :  
 +0.350 volts for  $2\text{e}^- + \text{Cu}^{2+}(\text{aq}) \rightarrow \text{Cu}$  and -0.763 volts for  $2\text{e}^- + \text{Zn}^{2+}(\text{aq}) \rightarrow \text{Zn}$ 
  - Write down the cell reaction.
  - Calculate the emf of the cell.
  - Is the cell reaction spontaneous or not?
- In an electrolysis experiment current was passed for 5 hours through two cells connected in series. The first cell contains a solution of gold and the second contains copper sulphate solution. 9.85 g of gold was deposited in the first cell. If the oxidation number of gold is +3, find the amount of copper deposited on the cathode of the second cell. Also calculate the magnitude of the current in amperes. (1 faraday = 96,500 coulombs) (1983 - 3 Marks)
- How long a current of 3 ampere has to be passed through a solution of silver nitrate to coat a metal surface of  $80 \text{ cm}^2$  with a 0.005 mm thick layer? Density of silver is  $10.5 \text{ g/cm}^3$  (1985 - 3 Marks)
- The EMF of a cell corresponding to the reaction :  

$$\text{Zn}(\text{s}) + 2\text{H}^+(\text{aq}) \rightarrow \text{Zn}^{2+}(\text{aq})(0.1 \text{ M}) + \text{H}_2(\text{g})(1 \text{ atm.})$$
 is 0.28 volt at  $25^\circ\text{C}$ .  
 Write the half-cell reactions and calculate the pH of the solution at the hydrogen electrode.  

$$E^\circ_{\text{Zn}^{2+}/\text{Zn}} = -0.76 \text{ volt}; E^\circ_{\text{H}^+/\text{H}_2} = 0 \quad (1986 - 4 \text{ Marks})$$
- During the discharge of a lead storage battery, the density of sulphuric acid fell from 1.294 to 1.139 g/ml. Sulphuric acid of density 1.294 g/ml is 39% by weight and that of 1.139 g/ml is 20%  $\text{H}_2\text{SO}_4$  by weight. The battery holds 3.5 litres of the acid and the volume remained practically constant during the discharge.  
 Calculate the number of ampere-hours for which the battery must have been used. The charging and discharging reactions are : (1986 - 5 Marks)
 

**Anode :**

$$\text{Pb} + \text{SO}_4^{2-} = \text{PbSO}_4 + 2\text{e}^- \text{ (discharging)}$$

**Cathode :**

$$\text{PbO}_2 + 4\text{H}^+ + \text{SO}_4^{2-} + 2\text{e}^- = \text{PbSO}_4 + 2\text{H}_2\text{O} \text{ (discharging)}$$

**Note :** Both the reactions take place at the anode and cathode respectively during discharge. Both reaction get reverse during charging.
- A 100 watt, 110 volt incandescent lamp is connected in series with an electrolyte cell containing cadmium sulphate solution. What weight of cadmium will be deposited by the current flowing for 10 hours? (1987 - 5 Marks)
- A cell contains two hydrogen electrodes. The negative electrode is in contact with a solution of  $10^{-6} \text{ M}$  hydrogen ions. The EMF of the cell is 0.118 V at  $25^\circ\text{C}$ . Calculate the concentration of hydrogen ions at the positive electrode. (1988 - 2 Marks)

11. In a fuel cell hydrogen and oxygen react to produce electricity. In the process hydrogen gas is oxidised at the anode and oxygen at the cathode. If 67.2 litre of  $H_2$  at STP react in 15 minutes, what is the average current produced? If the entire current is used for electro deposition of copper from copper (II) solution, how many grams of copper will be deposited? (1988 - 4 Marks)
- Anode reaction :  $H_2 + 2OH^- \rightarrow 2H_2O + 2e^-$
- Cathode reaction :  $\frac{1}{2}O_2 + H_2O + 2e^- \rightarrow 2OH^-$
12. An acidic solution of  $Cu^{2+}$  salt containing 0.4 g of  $Cu^{2+}$  is electrolysed until all the copper is deposited. The electrolysis is continued for seven more minutes with the volume of solution kept at 100 ml. and the current at 1.2 amp. Calculate the volume of gases evolved at NTP during the entire electrolysis. (1989 - 5 Marks)
13. The standard reduction potential at 25°C of the reaction,  $2H_2O + 2e^- \rightleftharpoons H_2 + 2OH^-$  is  $-0.8277V$ . Calculate the equilibrium constant for the reaction  $2H_2O \rightleftharpoons H_3O^+ + OH^-$  at 25°C. (1989 - 3 Marks)
14. The standard reduction potential of  $Cu^{++}/Cu$  and  $Ag^+/Ag$  electrodes are 0.337 and 0.799 volt respectively. Construct a galvanic cell using these electrodes so that its standard e.m.f. is positive. For what concentration of  $Ag^+$  will the e.m.f. of the cell, at 25°C, be zero if the concentration of  $Cu^{++}$  is 0.01 M? (1990 - 3 Marks)
15. Calculate the quantity of electricity that would be required to reduce 12.3 g of nitrobenzene to aniline, if the current efficiency for the process is 50 per cent. If the potential drop across the cell is 3.0 volts, how much energy will be consumed? (1990 - 3 Marks)
16. Zinc granules are added in excess to a 500 ml. of 1.0 M nickel nitrate solution at 25°C until the equilibrium is reached. If the standard reduction potential of  $Zn^{2+} | Zn$  and  $Ni^{2+} | Ni$  are  $-0.75 V$  and  $-0.24 V$  respectively, find out the concentration of  $Ni^{2+}$  in solution at equilibrium. (1991 - 2 Marks)
17. A current of 1.70 A is passed through 300.0 ml of 0.160 M solution of a  $ZnSO_4$  for 230 sec. with a current efficiency of 90%. Find out the molarity of  $Zn^{2+}$  after the deposition of Zn. Assume the volume of the solution to remain constant during the electrolysis. (1991 - 4 Marks)
18. For the galvanic cell. (1992 - 4 Marks)
- $Ag|AgCl(s), KCl(0.2 M) || KBr(0.001M), AgBr(s)|Ag$
- Calculate the EMF generated and assign correct polarity to each electrode for a spontaneous process after taking into account the cell reaction at 25°C.
- $[K_{sp}(AgCl) = 2.8 \times 10^{-10}, K_{sp}(AgBr) = 3.3 \times 10^{-13}]$
19. An aqueous solution of NaCl on electrolysis gives  $H_2(g)$ ,  $Cl_2(g)$  and NaOH according to the reaction :
- $$2Cl^-(aq) + 2H_2O = 2OH^-(aq) + H_2(g) + Cl_2(g).$$
- A direct current of 25 amperes with a current efficiency of 62% is passed through 20 litres of NaCl solution (20% by weight). Write down the reactions taking place at the anode and the cathode. How long will it take to produce 1 kg of  $Cl_2$ ? What will be the molarity of the solution with respect to hydroxide ion? (Assume no loss due to evaporation.) (1992 - 3 Marks)
20. The standard reduction potential for the half-cell  $NO_3^-(aq) + 2H^+(aq) + e^- \rightarrow NO_2(g) + H_2O$  is 0.78 V.
- (i) Calculate the reduction potential in 8 M  $H^+$
- (ii) What will be the reduction potential of the half-cell in a neutral solution? Assume all the other species to be at unit concentration. (1993 - 2 Marks)
21. Chromium metal can be plated out from an acidic solution containing  $CrO_3$  according to the following equation.
- $$CrO_3(aq) + 6H^+(aq) + 6e^- \rightarrow Cr(s) + 3H_2O$$
- Calculate (i) how many grams of chromium will be plated out by 24,000 coulombs and (ii) how long will it take to plate out 1.5 g of chromium by using 12.5 amp current. (1993 - 2 Marks)
22. The standard reduction potential of the  $Ag^+ / Ag$  electrode at 298 K is 0.799 V. Given that for  $AgI$ ,  $K_{sp} = 8.7 \times 10^{-17}$ , evaluate the potential of the  $Ag^+ / Ag$  electrode in a saturated solution of  $AgI$ . Also calculate the standard reduction potential of the  $I^- / AgI / Ag$  electrode. (1994 - 3 Marks)
23. The Edison storage cells is represented as
- $$Fe(s) | FeO(s) | KOH(aq) | Ni_2O_3(s) | Ni(s)$$
- The half-cell reactions are :
- $$Ni_2O_3(s) + H_2O(l) + 2e^- \rightleftharpoons 2NiO(s) + 2OH^- ; E^\circ = +0.40V$$
- $$FeO(s) + H_2O(l) + 2e^- \rightleftharpoons Fe(s) + 2OH^- ; E^\circ = -0.87V$$
- (i) What is the cell reaction ?
- (ii) What is the cell e.m.f ? How does it depend on the concentration of KOH?
- (iii) What is the maximum amount of electrical energy that can be obtained from one mole of  $Ni_2O_3$ ? (1994 - 4 Marks)
24. Although aluminium is above hydrogen in the electrochemical series, it is stable in air and water. Explain. (1994 - 1 Mark)

25. An excess of liquid mercury is added to an acidified solution of  $1.0 \times 10^{-3} \text{ M Fe}^{3+}$ . It is found that 5% of  $\text{Fe}^{3+}$  remains at equilibrium at  $25^\circ\text{C}$ . Calculate  $E^\circ_{\text{Hg}_2^{2+}|\text{Hg}}$ , assuming that the only reaction that occurs is

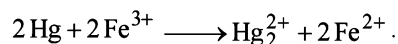

(Given  $E^\circ_{\text{Fe}^{3+}|\text{Fe}^{2+}} = 0.77 \text{ V}$ .) (1995 - 4 Marks)

26. The standard reduction potential for  $\text{Cu}^{2+}|\text{Cu}$  is  $+0.34 \text{ V}$ . Calculate the reduction potential at  $\text{pH} = 14$  for the above couple.  $K_{\text{sp}}$  of  $\text{Cu}(\text{OH})_2$  is  $1.0 \times 10^{-19}$  (1996 - 3 Marks)
27. How many grams of silver could be plated out on a serving tray by electrolysis of a solution containing silver in +1 oxidation state for a period of 8.0 hours at a current of 8.46 amperes? What is the area of the tray if the thickness of the silver plating is  $0.00254 \text{ cm}$ ? Density of silver is  $10.5 \text{ g/cm}^3$ . (1997 - 3 Marks)

28. Calculate the equilibrium constant for the reaction

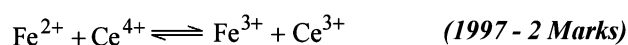

(given  $E^\circ_{\text{Ce}^{4+}/\text{Ce}^{3+}} = 1.44 \text{ V}$ ;  $E^\circ_{\text{Fe}^{3+}/\text{Fe}^{2+}} = 0.68 \text{ V}$ ;) )

29. Calculate the equilibrium constant for the reaction,  $2\text{Fe}^{3+} + 3\text{I}^- \rightleftharpoons 2\text{Fe}^{2+} + \text{I}_3^-$ . The standard reduction potentials in acidic conditions are  $0.77 \text{ V}$  and  $0.54 \text{ V}$  respectively for  $\text{Fe}^{3+}|\text{Fe}^{2+}$  and  $\text{I}_3^-|\text{I}^-$  couples. (1998 - 3 Marks)

30. Find the solubility product of a saturated solution of  $\text{Ag}_2\text{CrO}_4$  in water at  $298 \text{ K}$  if the emf of the cell  $\text{Ag}|\text{Ag}^+(\text{satd. } \text{Ag}_2\text{CrO}_4 \text{ soln.})||\text{Ag}^+(0.1\text{M})|\text{Ag}$  is  $0.164 \text{ V}$  at  $298 \text{ K}$ . (1998 - 6 Marks)
31. A cell,  $\text{Ag}|\text{Ag}^+||\text{Cu}^{2+}|\text{Cu}$ , initially contains  $1 \text{ M Ag}^+$  and  $1 \text{ M Cu}^{2+}$  ions. Calculate the change in the cell potential after the passage of  $9.65 \text{ A}$  of current for  $1 \text{ h}$ . (1999 - 6 Marks)
32. Copper sulphate solution ( $250 \text{ mL}$ ) was electrolysed using a platinum anode and a copper cathode. A constant current of  $2 \text{ mA}$  was passed for  $16 \text{ minutes}$ . It was found that after electrolysis the absorbance of the solution was reduced to  $50\%$  of its original value. Calculate the concentration of copper sulphate in the solution to begin with. (2000 - 3 Marks)

33. The following electrochemical cell has been set up.  
 $\text{Pt}(1)|\text{Fe}^{3+}, \text{Fe}^{2+} (a = 1)|\text{Ce}^{4+}, \text{Ce}^{3+} (a = 1)|\text{Pt}(2)$   
 $E^\circ(\text{Fe}^{3+}, \text{Fe}^{2+}) = 0.77 \text{ V}$ ;  $E^\circ(\text{Ce}^{4+}/\text{Ce}^{3+}) = 1.61 \text{ V}$   
 If an ammeter is connected between the two platinum electrodes, predict the direction of flow of current. Will the current increase or decrease with time? (2000 - 2 Marks)
34. The standard potential of the following cell is  $0.23 \text{ V}$  at  $15^\circ\text{C}$  and  $0.21 \text{ V}$  at  $35^\circ\text{C}$ . (2001 - 10 Marks)
- $$\text{Pt} | \text{H}_2(\text{g}) | \text{HCl}(\text{aq}) | \text{AgCl}(\text{s}) | \text{Ag}(\text{s})$$

- (i) Write the cell reaction.  
 (ii) Calculate  $\Delta H^\circ$  and  $\Delta S^\circ$  for the cell reaction by assuming that these quantities remain unchanged in the range  $15^\circ\text{C}$  to  $35^\circ\text{C}$ .

(iii) Calculate the solubility of  $\text{AgCl}$  in water at  $25^\circ\text{C}$ .

**Given :** The standard reduction potential of the  $\text{Ag}^+(\text{aq})/\text{Ag}(\text{s})$  couple is  $0.80 \text{ V}$  at  $25^\circ\text{C}$ .

35. Two students use same stock solution of  $\text{ZnSO}_4$  and a solution of  $\text{CuSO}_4$ . The emf of one cell is  $0.03 \text{ V}$  higher than the other. The conc. of  $\text{CuSO}_4$  in the cell with higher emf value is  $0.5 \text{ M}$ . Find out the conc. of  $\text{CuSO}_4$  in the other cell ( $2.303 \text{ RT/F} = 0.06$ ). (2003 - 2 Marks)

36. Find the equilibrium constant for the reaction,

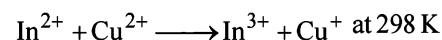

given :

$$E^\circ_{\text{Cu}^{2+}/\text{Cu}^+} = 0.15 \text{ V}; \quad E^\circ_{\text{In}^{2+}/\text{In}^+} = -0.40 \text{ V}, \quad E^\circ_{\text{In}^{3+}/\text{In}^+} = -0.42 \text{ V}$$

(2004 - 4 Marks)

37. (a) For the reaction

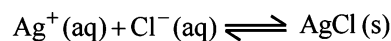

Given :

Species	$\Delta G_f^\circ$ (kJ/mol)
$\text{Ag}^+(\text{aq})$	+77
$\text{Cl}^-(\text{aq})$	-129
$\text{AgCl}(\text{s})$	-109

Write the cell representation of above reaction and calculate  $E^\circ_{\text{cell}}$  at  $298 \text{ K}$ . Also find the solubility product of  $\text{AgCl}$ .

- (b) If  $6.539 \times 10^{-2} \text{ g}$  of metallic zinc is added to  $100 \text{ ml}$  saturated solution of  $\text{AgCl}$ . Find the value of  $\log_{10} \frac{[\text{Zn}^{2+}]}{[\text{Ag}^+]^2}$ .

How many moles of  $\text{Ag}$  will be precipitated in the above reaction. Given that

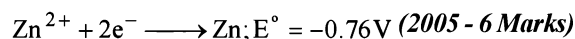
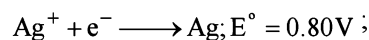

(It was given that Atomic mass of  $\text{Zn} = 65.39$ )

38. We have taken a saturated solution of  $\text{AgBr}$ .  $K_{\text{sp}}$  of  $\text{AgBr}$  is  $12 \times 10^{-14}$ . If  $10^{-7} \text{ mole}$  of  $\text{AgNO}_3$  are added to  $1 \text{ litre}$  of this solution find conductivity (specific conductance) of this solution in terms of  $10^{-7} \text{ S m}^{-1}$  units. Given, Molar conductance of  $\text{Ag}^+$ ,  $\text{Br}^-$  and  $\text{NO}_3^-$  are  $6 \times 10^{-3} \text{ Sm}^2\text{mol}^{-1}$ ,  $8 \times 10^{-3} \text{ Sm}^2\text{mol}^{-1}$  and  $7 \times 10^{-3} \text{ Sm}^2\text{mol}^{-1}$ . (2006 - 6M)

## F Match the Following

**DIRECTION (for Q. 1) :** Each question contains statements given in two columns, which have to be matched. The statements in Column-I are labelled A, B, C and D, while the statements in Column-II are labelled p, q, r, s and t. Any given statement in Column-I can have correct matching with ONE OR MORE statement(s) in Column-II. The appropriate bubbles corresponding to the answers to these questions have to be darkened as illustrated in the following example :

If the correct matches are A-p, s and t; B-q and r; C-p and q; and D-s then the correct darkening of bubbles will look like the given.

	p	q	r	s	t
A	<input checked="" type="radio"/>	<input type="radio"/>	<input type="radio"/>	<input checked="" type="radio"/>	<input checked="" type="radio"/>
B	<input type="radio"/>	<input checked="" type="radio"/>	<input checked="" type="radio"/>	<input type="radio"/>	<input type="radio"/>
C	<input checked="" type="radio"/>	<input checked="" type="radio"/>	<input type="radio"/>	<input type="radio"/>	<input type="radio"/>
D	<input type="radio"/>	<input type="radio"/>	<input type="radio"/>	<input checked="" type="radio"/>	<input type="radio"/>

1. Match the reactions in Columns I with nature of the reactions/type of the products in Column II. Indicate your answer by darkening the appropriate bubbles of the  $4 \times 4$  matrix given in the ORS. (2007)

Column I	Column II
(A) $O_2^- \rightarrow O_2 + O_2^{2-}$	(p) redox reaction
(B) $CrO_4^{2-} + H^+ \rightarrow$	(q) one of the products has trigonal planar structure
(C) $MnO_4^- + NO_2^- + H^+ \rightarrow$	(r) dimeric bridged tetrahedral metal ion
(D) $NO_3^- + H_2SO_4 + Fe^{2+} \rightarrow$	(s) disproportionation

**DIRECTION (for Q. 2 & 3) :** Following questions have matching lists. The codes for the lists have choices (a), (b), (c) and (d) out of which ONLY ONE is correct.

2. An aqueous solution of X is added slowly to an aqueous solution of Y as shown in List I. The variation in conductivity of these reactions is given in List II. Match list I with List II and select the correct answer using the code given below the lists : (JEE Adv. 2013)

List I	List II
P. $(C_2H_5)_3N + CH_3COOH$ X Y	1. Conductivity decreases and then increases
Q. $KI(0.1M) + AgNO_3(0.01M)$ X Y	2. Conductivity decreases and then does not change much
R. $CH_3COOH + KOH$ X Y	3. Conductivity increases and then does not change much
S. $NaOH + HI$ X Y	4. Conductivity does not change much and then increases

Codes :

	P	Q	R	S
(a)	3	4	2	1
(b)	4	3	2	1
(c)	2	3	4	1
(d)	1	4	3	2

3. The standard reduction potential data at  $25^\circ C$  is given below : (JEE Adv. 2013)

$E^\circ(Fe^{3+}, Fe^{2+}) = +0.77 V$ ;  $E^\circ(Fe^{2+}, Fe) = -0.44 V$ ;  $E^\circ(Cu^{2+}, Cu) = +0.34 V$ ;  $E^\circ(Cu^+, Cu) = +0.52 V$   
 $E^\circ[O_2(g) + 4H^+ + 4e^- \rightarrow 2H_2O] = +1.23 V$ ;  $E^\circ[O_2(g) + 2H_2O + 4e^- \rightarrow 4OH^-] = +0.40 V$   
 $E^\circ(Cr^{3+}, Cr) = -0.74 V$ ;  $E^\circ(Cr^{2+}, Cr) = -0.91 V$

Match  $E^\circ$  of the redox pair in List I with the values given in List II and select the correct answer using the code given below the lists :

List I	List II
P. $E^\circ(Fe^{3+}, Fe)$	1. $-0.18 V$
Q. $E^\circ(4H_2O \rightleftharpoons 4H^+ + 4OH^-)$	2. $-0.4 V$
R. $E^\circ(Cu^{2+} + Cu \rightarrow 2Cu^+)$	3. $-0.04 V$
S. $E^\circ(Cr^{3+}, Cr^{2+})$	4. $-0.83 V$

Codes :

	P	Q	R	S
(a)	4	1	2	3
(b)	2	3	4	1
(c)	1	2	3	4
(d)	3	4	1	2

## G Comprehension Based Questions

### PASSAGE : I

Tollen's test is given by aldehydes.

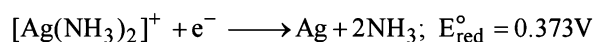
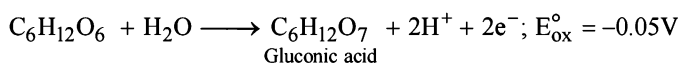

$$\text{Given } \frac{2.303RT}{F} = 0.0591 \text{ \& } \left( \frac{F}{RT} \right) = 38.92 \text{ V}^{-1}$$

1. Calculate (ln K) for

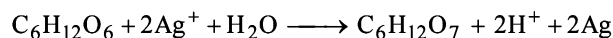

- (a) 55.6 (b) 29.6 (2006 - 5M, -2)  
(c) 66 (d) 58.38
2. On adding  $\text{NH}_3$ , pH of the solution increases to 11 then, identify the effect on potential of half-cell (2006 - 5M, -2)
- (a)  $E_{\text{ox}}$  increased from  $E_{\text{ox}}^\circ$  by 0.65 V  
(b)  $E_{\text{ox}}$  decreased from  $E_{\text{ox}}^\circ$  by 0.65 V  
(c)  $E_{\text{red}}$  increased from  $E_{\text{red}}^\circ$  by 0.65 V  
(d)  $E_{\text{red}}$  decreased from  $E_{\text{red}}^\circ$  by 0.65 V
3.  $\text{NH}_3$  is used in this reaction rather than any other base. Select the correct statement out of the following (2006 - 5M, -2)
- (a)  $[\text{Ag}(\text{NH}_3)_2]^+$  is a weaker oxidizing agent than  $\text{Ag}^+$   
(b) to dissolve the insoluble silver oxide formed under the reaction conditions  
(c) Ag precipitates gluconic acid as its silver salt  
(d)  $\text{NH}_3$  changes the standard reduction potential of  $[\text{Ag}(\text{NH}_3)_2]^+$

### PASSAGE : II

Chemical reactions involve interaction of atoms and molecules. A large number of atoms/molecules (approximately  $6.023 \times 10^{23}$ ) are present in a few grams of any chemical compound varying with their atomic/molecular masses. To handle such large numbers conveniently, the mole concept was introduced. This concept has implications in diverse areas such as analytical chemistry, biochemistry, electrochemistry and radiochemistry. The following example illustrates a typical case, involving chemical/electrochemical reaction, which requires a clear understanding of the mole concept. A 4.0 molar aqueous solution of NaCl is prepared and 500 mL of this solution is electrolysed. This leads to the evolution of chlorine gas at one of the electrodes (atomic mass : Na = 23, Hg = 200; 1 Faraday = 96500 coulombs).

4. The total number of moles of chlorine gas evolved is (2007)
- (a) 0.5 (b) 1.0  
(c) 2.0 (d) 3.0

5. If the cathode is a Hg electrode, the maximum weight (g) of amalgam formed from this solution is (2007)
- (a) 200 (b) 225  
(c) 400 (d) 446
6. The total charge (coulombs) required for complete electrolysis is (2007)
- (a) 24125 (b) 48250  
(c) 96500 (d) 193000

### PASSAGE : III

Redox reactions play a pivotal role in chemistry and biology. The values of standard redox potential ( $E^\circ$ ) of two half-cell reactions decide which way the reaction is expected to proceed. A simple example is a Daniel cell in which zinc goes into solution and copper gets deposited. Given below are a set of half-cell reactions (acidic medium) along with their  $E^\circ$  (V with respect to normal hydrogen electrode) values. Using this data obtain the correct explanations to questions given.

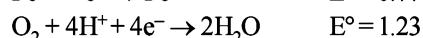
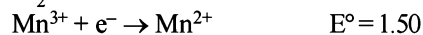

7. Among the following, identify the correct statement. (2007)
- (a) Chloride ion is oxidised by  $\text{O}_2$   
(b)  $\text{Fe}^{2+}$  is oxidised by iodine  
(c) Iodide ion is oxidised by chlorine  
(d)  $\text{Mn}^{2+}$  is oxidised by chlorine
8. While  $\text{Fe}^{3+}$  is stable,  $\text{Mn}^{3+}$  is not stable in acid solution because (2007)
- (a)  $\text{O}_2$  oxidises  $\text{Mn}^{2+}$  to  $\text{Mn}^{3+}$   
(b)  $\text{O}_2$  oxidises both  $\text{Mn}^{2+}$  to  $\text{Mn}^{3+}$  and  $\text{Fe}^{2+}$  to  $\text{Fe}^{3+}$   
(c)  $\text{Fe}^{3+}$  oxidises  $\text{H}_2\text{O}$  to  $\text{O}_2$   
(d)  $\text{Mn}^{3+}$  oxidises  $\text{H}_2\text{O}$  to  $\text{O}_2$
9. Sodium fusion extract, obtained from aniline, on treatment with iron (II) sulphate and  $\text{H}_2\text{SO}_4$  in presence of air gives a Prussian blue precipitate. The blue colour is due to the formation of (2007)
- (a)  $\text{Fe}_4[\text{Fe}(\text{CN})_6]_3$  (b)  $\text{Fe}_3[\text{Fe}(\text{CN})_6]_2$   
(c)  $\text{Fe}_4[\text{Fe}(\text{CN})_6]_2$  (d)  $\text{Fe}_3[\text{Fe}(\text{CN})_6]_3$

### PASSAGE : IV

The concentration of potassium ions inside a biological cell is atleast twenty times higher than the outside. The resulting potential difference across the cell is important in several processes such as transmission of nerve impulses and maintaining the ion balance. A simple model for such a concentration cell involving a metal M is  $\text{M}(\text{s}) | \text{M}^+(\text{aq}; 0.05 \text{ molar}) || \text{M}^+(\text{aq}; 1 \text{ molar}) | \text{M}(\text{s})$

For the above electrolytic cell the magnitude of the cell potential  $|E_{\text{cell}}| = 70 \text{ mV}$ . (2010)

10. For the above cell
- (a)  $E_{\text{cell}} < 0; \Delta G > 0$  (b)  $E_{\text{cell}} > 0; \Delta G < 0$   
(c)  $E_{\text{cell}} < 0; \Delta G^\circ > 0$  (d)  $E_{\text{cell}} > 0; \Delta G^\circ < 0$
11. If the 0.05 molar solution of  $\text{M}^+$  is replaced by a 0.0025 molar  $\text{M}^+$  solution, then the magnitude of the cell potential would be
- (a) 35mV (b) 70mV (c) 140mV (d) 700mV

## PASSAGE : V

The electrochemical cell shown below is a concentration cell.

$M | M^{2+}$  (saturated solution of a sparingly soluble salt,  $MX_2$ )  $|| M^{2+}$  (0.001 mol dm<sup>-3</sup>)  $| M$ .

The emf of the cell depends on the difference in concentrations of  $M^{2+}$  ions at the two electrodes. The emf of the cell at 298 K is 0.059 V. (2012)

12. The value of  $\Delta G$  (kJ mol<sup>-1</sup>) for the given cell is (take  $1F = 96500 \text{ C mol}^{-1}$ )  
 (a) -5.7 (b) 5.7 (c) 11.4 (d) -11.4
13. The solubility product ( $K_{sp}$ ; mol<sup>3</sup> dm<sup>-9</sup>) of  $MX_2$  at 298 K based on the information available for the given concentration cell is (take  $2.303 \times R \times 298/F = 0.059 \text{ V}$ )  
 (a)  $1 \times 10^{-15}$  (b)  $4 \times 10^{-15}$   
 (c)  $1 \times 10^{-12}$  (d)  $4 \times 10^{-12}$

## Section-B

## JEE Main / AIEEE

1. Conductivity (unit Siemen's S) is directly proportional to area of the vessel and the concentration of the solution in it and is inversely proportional to the length of the vessel then the unit of the constant of proportionality is  
 (a) Sm mol<sup>-1</sup> (b) Sm<sup>2</sup> mol<sup>-1</sup> [2002]  
 (c) S<sup>-2</sup>m<sup>2</sup> mol (d) S<sup>2</sup>m<sup>2</sup> mol<sup>-2</sup>.
2. EMF of a cell in terms of reduction potential of its left and right electrodes is [2002]  
 (a)  $E = E_{\text{left}} - E_{\text{right}}$  (b)  $E = E_{\text{left}} + E_{\text{right}}$   
 (c)  $E = E_{\text{right}} - E_{\text{left}}$  (d)  $E = -(E_{\text{right}} + E_{\text{left}})$ .
3. What will be the emf for the given cell [2002]  
 $\text{Pt} | \text{H}_2(P_1) | \text{H}^+(\text{aq}) || \text{H}_2(P_2) | \text{Pt}$   
 (a)  $\frac{RT}{F} \log_e \frac{P_1}{P_2}$  (b)  $\frac{RT}{2F} \log_e \frac{P_1}{P_2}$   
 (c)  $\frac{RT}{F} \log_e \frac{P_2}{P_1}$  (d) None of these.
4. Which of the following reaction is possible at anode?  
 (a)  $2 \text{Cr}^{3+} + 7\text{H}_2\text{O} \rightarrow \text{Cr}_2\text{O}_7^{2-} + 14\text{H}^+$  [2002]  
 (b)  $\text{F}_2 \rightarrow 2\text{F}^-$   
 (c)  $(1/2) \text{O}_2 + 2\text{H}^+ \rightarrow \text{H}_2\text{O}$   
 (d) None of these.
5. When the sample of copper with zinc impurity is to be purified by electrolysis, the appropriate electrodes are  

<b>Cathode</b>	<b>Anode</b>	[2002]
(a) pure zinc	pure copper	
(b) impure sample	pure copper	
(c) impure zinc	impure sample	
(d) pure copper	impure sample.	
6. Which of the following is a redox reaction? [2002]  
 (a)  $\text{NaCl} + \text{KNO}_3 \rightarrow \text{NaNO}_3 + \text{KCl}$   
 (b)  $\text{CaC}_2\text{O}_4 + 2\text{HCl} \rightarrow \text{CaCl}_2 + \text{H}_2\text{C}_2\text{O}_4$   
 (c)  $\text{Mg}(\text{OH})_2 + 2\text{NH}_4\text{Cl} \rightarrow \text{MgCl}_2 + 2\text{NH}_4\text{OH}$   
 (d)  $\text{Zn} + 2\text{AgCN} \rightarrow 2\text{Ag} + \text{Zn}(\text{CN})_2$ .
7. For a cell reaction involving a two-electron change, the standard e.m.f. of the cell is found to be 0.295 V at 25°C. The equilibrium constant of the reaction at 25°C will be  
 (a)  $29.5 \times 10^{-2}$  (b) 10 [2003]  
 (c)  $1 \times 10^{10}$  (d)  $1 \times 10^{-10}$
8. Standard reduction electrode potentials of three metals A, B & C are respectively +0.5 V, -3.0 V & -1.2 V. The reducing powers of these metals are [2003]  
 (a)  $A > B > C$  (b)  $C > B > A$   
 (c)  $A > C > B$  (d)  $B > C > A$
9. When during electrolysis of a solution of  $\text{AgNO}_3$  9650 coulombs of charge pass through the electroplating bath, the mass of silver deposited on the cathode will be  
 (a) 10.8 g (b) 21.6 g [2003]  
 (c) 108 g (d) 1.08 g
10. For the redox reaction : [2003]  
 $\text{Zn}(\text{s}) + \text{Cu}^{2+}(0.1\text{M}) \rightarrow \text{Zn}^{2+}(1\text{M}) + \text{Cu}(\text{s})$   
 taking place in a cell,  $E_{\text{cell}}^\circ$  is 1.10 volt.  $E_{\text{cell}}$  for the cell will be  $\left( 2.303 \frac{RT}{F} = 0.0591 \right)$   
 (a) 1.80 volt (b) 1.07 volt [2003]  
 (c) 0.82 volt (d) 2.14 volt
11. Several blocks of magnesium are fixed to the bottom of a ship to  
 (a) make the ship lighter  
 (b) prevent action of water and salt  
 (c) prevent puncturing by under-sea rocks  
 (d) keep away the sharks

## I Integer Value Correct Type

1. All the energy released from the reaction  $X \rightarrow Y$ ,  $\Delta_r G^\circ = -193 \text{ kJ mol}^{-1}$  is used for oxidizing  $M^+$  as  $M^+ \rightarrow M^{3+} + 2e^-$ ,  $E^\circ = -0.25 \text{ V}$

Under standard conditions, the number of moles of  $M^+$  oxidized when one mole of X is converted to Y is

[ $F = 96500 \text{ C mol}^{-1}$ ] (JEE Adv. 2015)

2. The molar conductivity of a solution of a weak acid HX (0.01 M) is 10 times smaller than the molar conductivity of a solution of a weak acid HY (0.10 M). If  $\lambda_x^0 \approx \lambda_y^0$  the difference in their  $\text{pK}_a$  values,  $\text{pK}_a(\text{HX}) - \text{pK}_a(\text{HY})$ , is (consider degree of ionization of both acids to be  $\ll 1$ ) (JEE Adv. 2015)



12. In a hydrogen-oxygen fuel cell, combustion of hydrogen occurs to [2004]  
 (a) produce high purity water  
 (b) create potential difference between two electrodes  
 (c) generate heat  
 (d) remove adsorbed oxygen from electrode surfaces

13. Consider the following  $E^\circ$  values

$$E^\circ_{\text{Fe}^{3+}/\text{Fe}^{2+}} = +0.77\text{V}; E^\circ_{\text{Sn}^{2+}/\text{Sn}} = -0.14\text{V}$$

Under standard conditions the potential for the reaction

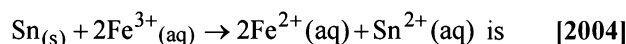

- (a) 0.91 V (b) 1.40 V  
 (c) 1.68 V (d) 0.63 V
14. The standard e.m.f. of a cell involving one electron change is found to be 0.591 V at 25°C. The equilibrium constant of the reaction is ( $F = 96,500 \text{ C mol}^{-1}$ ;  $R = 8.314 \text{ JK}^{-1} \text{ mol}^{-1}$ ) [2004]  
 (a)  $1.0 \times 10^{10}$  (b)  $1.0 \times 10^5$   
 (c)  $1.0 \times 10^1$  (d)  $1.0 \times 10^{30}$
15. The limiting molar conductivities  $\Lambda^\circ$  for NaCl, KBr and KCl are 126, 152 and 150  $\text{S cm}^2 \text{ mol}^{-1}$  respectively. The  $\Lambda^\circ$  for NaBr is [2004]  
 (a)  $278 \text{ S cm}^2 \text{ mol}^{-1}$  (b)  $176 \text{ S cm}^2 \text{ mol}^{-1}$   
 (c)  $128 \text{ S cm}^2 \text{ mol}^{-1}$  (d)  $302 \text{ S cm}^2 \text{ mol}^{-1}$
16. In a cell that utilises the reaction

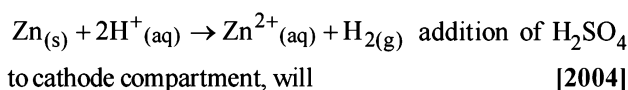

- (a) increase the E and shift equilibrium to the right  
 (b) lower the E and shift equilibrium to the right  
 (c) lower the E and shift equilibrium to the left  
 (d) increase the E and shift equilibrium to the left
17. The  $E^\circ_{\text{M}^{3+}/\text{M}^{2+}}$  values for Cr, Mn, Fe and Co are  $-0.41$ ,  $+1.57$ ,  $+0.77$  and  $+1.97\text{V}$  respectively. For which one of these metals the change in oxidation state from +2 to +3 is easiest? [2004]  
 (a) Fe (b) Mn  
 (c) Cr (d) Co

18. For a spontaneous reaction the  $\Delta G$ , equilibrium constant (K) and  $E^\circ_{\text{Cell}}$  will be respectively [2005]

- (a)  $-ve, >1, -ve$  (b)  $-ve, <1, -ve$   
 (c)  $+ve, >1, -ve$  (d)  $-ve, >1, +ve$

19. The highest electrical conductivity of the following aqueous solutions is of [2005]

- (a) 0.1 M difluoroacetic acid  
 (b) 0.1 M fluoroacetic acid  
 (c) 0.1 M chloroacetic acid  
 (d) 0.1 M acetic acid

20. Aluminium oxide may be electrolysed at 1000°C to furnish aluminium metal (At. Mass = 27 amu; 1 Faraday = 96,500 Coulombs). The cathode reaction is  $\text{Al}^{3+} + 3e^- \rightarrow \text{Al}$ . To prepare 5.12 kg of aluminium metal by this method we require [2005]

- (a)  $5.49 \times 10^1 \text{ C}$  of electricity  
 (b)  $5.49 \times 10^4 \text{ C}$  of electricity  
 (c)  $1.83 \times 10^7 \text{ C}$  of electricity  
 (d)  $5.49 \times 10^7 \text{ C}$  of electricity

21.

Electrolyte:	KCl	KNO <sub>3</sub>	HCl	NaOAc	NaCl
$\Lambda^\circ (\text{S cm}^2 \text{ mol}^{-1})$ :	149.9	145	426.2	91	126.5

Calculate  $\Lambda^\circ_{\text{HOAc}}$  using appropriate molar conductances of the electrolytes listed above at infinite dilution in  $\text{H}_2\text{O}$  at 25°C [2005]

- (a) 217.5 (b) 390.7  
 (c) 552.7 (d) 517.2
22. Which of the following chemical reactions depict the oxidizing behaviour of  $\text{H}_2\text{SO}_4$ ? [2006]  
 (a)  $\text{NaCl} + \text{H}_2\text{SO}_4 \longrightarrow \text{NaHSO}_4 + \text{HCl}$   
 (b)  $2\text{PCl}_5 + \text{H}_2\text{SO}_4 \longrightarrow 2\text{POCl}_3 + 2\text{HCl} + \text{SO}_2\text{Cl}_2$   
 (c)  $2\text{HI} + \text{H}_2\text{SO}_4 \longrightarrow \text{I}_2 + \text{SO}_2 + 2\text{H}_2\text{O}$   
 (d)  $\text{Ca}(\text{OH})_2 + \text{H}_2\text{SO}_4 \longrightarrow \text{CaSO}_4 + 2\text{H}_2\text{O}$

23. The molar conductivities  $\Lambda^\circ_{\text{NaOAc}}$  and  $\Lambda^\circ_{\text{HCl}}$  at infinite dilution in water at 25°C are 91.0 and 426.2  $\text{S cm}^2/\text{mol}$  respectively. To calculate  $\Lambda^\circ_{\text{HOAc}}$ , the additional value required is [2006]

- (a)  $\Lambda^\circ_{\text{NaOH}}$  (b)  $\Lambda^\circ_{\text{NaCl}}$   
 (c)  $\Lambda^\circ_{\text{H}_2\text{O}}$  (d)  $\Lambda^\circ_{\text{KCl}}$

24. Resistance of a conductivity cell filled with a solution of an electrolyte of concentration 0.1 M is 100  $\Omega$ . The conductivity of this solution is  $1.29 \text{ S m}^{-1}$ . Resistance of the same cell when filled with 0.2 M of the same solution is 520  $\Omega$ . The molar conductivity of 0.2 M solution of electrolyte will be [2006]

- (a)  $1.24 \times 10^{-4} \text{ S m}^2 \text{ mol}^{-1}$  (b)  $12.4 \times 10^{-4} \text{ S m}^2 \text{ mol}^{-1}$   
 (c)  $124 \times 10^{-4} \text{ S m}^2 \text{ mol}^{-1}$  (d)  $1240 \times 10^{-4} \text{ S m}^2 \text{ mol}^{-1}$

25. The equivalent conductances of two strong electrolytes at infinite dilution in  $\text{H}_2\text{O}$  (where ions move freely through a solution) at 25°C are given below: [2007]

$$\Lambda^\circ_{\text{CH}_3\text{COONa}} = 91.0 \text{ S cm}^2/\text{equiv.}$$

$$\Lambda^\circ_{\text{HCl}} = 426.2 \text{ S cm}^2/\text{equiv.}$$

What additional information/ quantity one needs to calculate  $\Lambda^\circ$  of an aqueous solution of acetic acid?

- (a)  $\Lambda^\circ$  of chloroacetic acid ( $\text{ClCH}_2\text{COOH}$ )  
 (b)  $\Lambda^\circ$  of NaCl  
 (c)  $\Lambda^\circ$  of  $\text{CH}_3\text{COOK}$   
 (d) the limiting equivalent conductance of  $\text{H}^+$  ( $\lambda^\circ_{\text{H}^+}$ ).

26. The cell,  $\text{Zn} | \text{Zn}^{2+} (1 \text{ M}) || \text{Cu}^{2+} (1 \text{ M}) | \text{Cu}$  ( $E^\circ_{\text{cell}} = 1.10 \text{ V}$ ) was allowed to be completely discharged at 298 K. The relative concentration of  $\text{Zn}^{2+}$  to  $\text{Cu}^{2+}$   $\left( \frac{[\text{Zn}^{2+}]}{[\text{Cu}^{2+}]} \right)$  is [2007]
- (a)  $9.65 \times 10^4$  (b)  $\text{antilog}(24.08)$   
(c) 37.3 (d)  $10^{37.3}$
27. Given  $E^\circ_{\text{Cr}^{3+}/\text{Cr}} = -0.72 \text{ V}$ ,  $E^\circ_{\text{Fe}^{2+}/\text{Fe}} = -0.42 \text{ V}$ . The potential for the cell  $\text{Cr} | \text{Cr}^{3+} (0.1 \text{ M}) || \text{Fe}^{2+} (0.01 \text{ M}) | \text{Fe}$  is [2008]
- (a) 0.26 V (b) 0.336 V  
(c) -0.339 (d) 0.26 V
28. In a fuel cell methanol is used as fuel and oxygen gas is used as an oxidizer. The reaction is  $\text{CH}_3\text{OH}(l) + 3/2 \text{O}_2(g) \longrightarrow \text{CO}_2(g) + 2\text{H}_2\text{O}(l)$ . At 298 K standard Gibb's energies of formation for  $\text{CH}_3\text{OH}(l)$ ,  $\text{H}_2\text{O}(l)$  and  $\text{CO}_2(g)$  are  $-166.2$ ,  $-237.2$  and  $-394.4 \text{ kJ mol}^{-1}$  respectively. If standard enthalpy of combustion of methanol is  $-726 \text{ kJ mol}^{-1}$ , efficiency of the fuel cell will be: [2009]
- (a) 87% (b) 90%  
(c) 97% (d) 80%
29. Given:  $E^\circ_{\text{Fe}^{3+}/\text{Fe}} = -0.036 \text{ V}$ ,  $E^\circ_{\text{Fe}^{2+}/\text{Fe}} = -0.439 \text{ V}$ . The value of standard electrode potential for the change,  $\text{Fe}^{3+}(\text{aq}) + e^- \longrightarrow \text{Fe}^{2+}(\text{aq})$  will be: [2009]
- (a) 0.385 V (b) 0.770 V  
(c) -0.270 V (d) -0.072 V
30. The Gibbs energy for the decomposition of  $\text{Al}_2\text{O}_3$  at  $500^\circ\text{C}$  is as follows:
- $$\frac{2}{3} \text{Al}_2\text{O}_3 \rightarrow \frac{4}{3} \text{Al} + \text{O}_2, \Delta_r G = +966 \text{ kJ mol}^{-1}$$
- The potential difference needed for electrolytic reduction of  $\text{Al}_2\text{O}_3$  at  $500^\circ\text{C}$  is at least [2010]
- (a) 4.5 V (b) 3.0 V  
(c) 2.5 V (d) 5.0 V
31. The correct order of  $E^\circ_{\text{M}^{2+}/\text{M}}$  values with negative sign for the four successive elements Cr, Mn, Fe and Co is [2010]
- (a)  $\text{Mn} > \text{Cr} > \text{Fe} > \text{Co}$  (b)  $\text{Cr} < \text{Fe} > \text{Mn} > \text{Co}$   
(c)  $\text{Fe} > \text{Mn} > \text{Cr} > \text{Co}$  (d)  $\text{Cr} > \text{Mn} > \text{Fe} > \text{Co}$
32. The reduction potential of hydrogen half-cell will be negative if: [2011]
- (a)  $p(\text{H}_2) = 1 \text{ atm}$  and  $[\text{H}^+] = 2.0 \text{ M}$   
(b)  $p(\text{H}_2) = 1 \text{ atm}$  and  $[\text{H}^+] = 1.0 \text{ M}$   
(c)  $p(\text{H}_2) = 2 \text{ atm}$  and  $[\text{H}^+] = 1.0 \text{ M}$   
(d)  $p(\text{H}_2) = 2 \text{ atm}$  and  $[\text{H}^+] = 2.0 \text{ M}$
33. The standard reduction potentials for  $\text{Zn}^{2+}/\text{Zn}$ ,  $\text{Ni}^{2+}/\text{Ni}$  and  $\text{Fe}^{2+}/\text{Fe}$  are  $-0.76$ ,  $-0.23$  and  $-0.44 \text{ V}$  respectively. The reaction  $\text{X} + \text{Y}^{2+} \longrightarrow \text{X}^{2+} + \text{Y}$  will be spontaneous when: [2012]
- (a)  $\text{X} = \text{Ni}$ ,  $\text{Y} = \text{Fe}$  (b)  $\text{X} = \text{Ni}$ ,  $\text{Y} = \text{Zn}$   
(c)  $\text{X} = \text{Fe}$ ,  $\text{Y} = \text{Zn}$  (d)  $\text{X} = \text{Zn}$ ,  $\text{Y} = \text{Ni}$
34. Given:  $E^\circ_{\text{Cr}^{3+}/\text{Cr}} = -0.74 \text{ V}$ ;  $E^\circ_{\text{MnO}_4^-/\text{Mn}^{2+}} = 1.51 \text{ V}$   
 $E^\circ_{\text{Cr}_2\text{O}_7^{2-}/\text{Cr}^{3+}} = 1.33 \text{ V}$ ;  $E^\circ_{\text{Cl}^-/\text{Cl}_2} = 1.36 \text{ V}$ . Based on the data given above, strongest oxidising agent will be: [JEE M 2013]
- (a) Cl (b)  $\text{Cr}^{3+}$   
(c)  $\text{Mn}^{2+}$  (d)  $\text{MnO}_4^-$
35. Resistance of 0.2 M solution of an electrolyte is 50  $\Omega$ . The specific conductance of the solution is  $1.4 \text{ S m}^{-1}$ . The resistance of 0.5 M solution of the same electrolyte is 280  $\Omega$ . The molar conductivity of 0.5 M solution of the electrolyte in  $\text{S m}^2 \text{ mol}^{-1}$  is: [JEE M 2014]
- (a)  $5 \times 10^{-4}$  (b)  $5 \times 10^{-3}$   
(c)  $5 \times 10^3$  (d)  $5 \times 10^2$
36. Given below are the half-cell reactions: [JEE M 2014]
- $$\text{Mn}^{2+} + 2e^- \rightarrow \text{Mn}; E^\circ = -1.18 \text{ V}$$
- $$2(\text{Mn}^{3+} + e^- \rightarrow \text{Mn}^{2+}); E^\circ = +1.51 \text{ V}$$
- The  $E^\circ$  for  $3\text{Mn}^{2+} \rightarrow \text{Mn} + 2\text{Mn}^{3+}$  will be:
- (a)  $-2.69 \text{ V}$ ; the reaction will not occur  
(b)  $-2.69 \text{ V}$ ; the reaction will occur  
(c)  $-0.33 \text{ V}$ ; the reaction will not occur  
(d)  $-0.33 \text{ V}$ ; the reaction will occur
37. The equivalent conductance of NaCl at concentration C and at infinite dilution are  $\lambda_C$  and  $\lambda_\infty$ , respectively. The correct relationship between  $\lambda_C$  and  $\lambda_\infty$  is given as: (Where the constant B is positive) [JEE M 2014]
- (a)  $\lambda_C = \lambda_\infty + (B)C$  (b)  $\lambda_C = \lambda_\infty - (B)C$   
(c)  $\lambda_C = \lambda_\infty - (B)\sqrt{C}$  (d)  $\lambda_C = \lambda_\infty + (B)\sqrt{C}$
38. Two Faraday of electricity is passed through a solution of  $\text{CuSO}_4$ . The mass of copper deposited at the cathode is (at. mass of Cu = 63.5 amu) [JEE M 2015]
- (a) 2g (b) 127g  
(c) 0g (d) 63.5g
39. Galvanization is applying a coating of: [JEE M 2016]
- (a) Cu (b) Zn  
(c) Pb (d) Cr

# CHAPTER 14

# Chemical Kinetics and Nuclear Chemistry

## Section-A JEE Advanced/ IIT-JEE

### A Fill in the Blanks

- An element  ${}^A_Z M$  undergoes an  $\alpha$ -emission followed by two successive  $\beta$ -emissions. The element formed is .....  
(1982 - 1 Mark)
- The rate of chemical change is directly proportional to .....  
(1985 - 1 Mark)
- The number of neutrons in the parent nucleus which gives  ${}^{14}_7 N$  on beta emission is .....  
(1985 - 1 Mark)
- The hydrolysis of ethyl acetate in ..... medium is a ..... order reaction.  
(1986 - 1 Mark)
- A radioactive nucleus decays emitting one alpha and two beta particles; the daughter nucleus is ..... of the parent.  
(1989 - 1 Mark)
- For the reaction  $N_2(g) + 3H_2(g) \longrightarrow 2NH_3(g)$ ,  
under certain conditions of temperature and partial pressure of the reactants, the rate of formation of  $NH_3$  is  $0.001 \text{ kg h}^{-1}$ . The rate of conversion of  $H_2$  under the same condition is .....  $\text{kg h}^{-1}$ .  
(1994 - 1 Mark)
- In the Arrhenius equation,  $k = A \exp(-E_a/RT)$ ,  $A$  may be termed as the rate constant at .....  
(1997 - 1 Mark)

### B True / False

- For a first order reaction, the rate of the reaction doubles as the concentration of the reactant (s) doubles.  
(1986 - 1 Mark)
- Catalyst makes a reaction more exothermic.  
(1987 - 1 Mark)
- Catalyst does not affect the energy of activation in a chemical reaction.  
(1989 - 1 Mark)
- In  $\beta$ -emission from a nucleus the atomic number of the daughter element decreases by one.  
(1990 - 1 Mark)
- The rate of an exothermic reaction increases with increasing temperature.  
(1990 - 1 Mark)

### C MCQs with One Correct Answer

- If uranium (mass number 238 and atomic number 92) emits an  $\alpha$ -particle, the product has mass no. and atomic no.  
(1981 - 1 Mark)  
(a) 236 and 92 (b) 234 and 90  
(c) 238 and 90 (d) 236 and 90
- The rate constant of a reaction depends on  
(a) temperature (1981 - 1 Mark)  
(b) initial concentration of the reactants  
(c) time of reaction  
(d) extent of reaction
- The specific rate constant of a first order reaction depends on the  
(1983 - 1 Mark)  
(a) concentration of the reactant  
(b) concentration of the product  
(c) time  
(d) temperature
- A catalyst is a substance which (1983 - 1 Mark)  
(a) increases the equilibrium concentration of the product  
(b) changes the equilibrium constant of the reaction  
(c) shortens the time to reach equilibrium  
(d) supplies energy to the reaction
- The radiations from a naturally occurring radioactive substance, as seen after deflection by a magnetic field in one direction, are : (1984 - 1 Mark)  
(a) definitely alpha rays (b) definitely beta rays  
(c) both alpha and beta rays (d) either alpha or beta rays
- The half-life period of a radioactive element is 140 days. After 560 days, one gram of the element will be reduced to :  
(1986 - 1 Mark)  
(a)  $\frac{1}{2}$  g (b)  $\frac{1}{4}$  g  
(c)  $\frac{1}{8}$  g (d)  $\frac{1}{16}$  g
- The rate constant, the activation energy and the Arrhenius parameter of a chemical reaction at  $25^\circ\text{C}$  are  $3.0 \times 10^{-4} \text{ s}^{-1}$ ,  $104.4 \text{ kJ mol}^{-1}$  and  $6.0 \times 10^{14} \text{ s}^{-1}$  respectively. The value of the rate constant as  $T \rightarrow \infty$  is, (1996 - 1 Mark)

- (a)  $2.0 \times 10^{18} \text{ s}^{-1}$  (b)  $6.0 \times 10^{14} \text{ s}^{-1}$   
 (c) infinity (d)  $3.6 \times 10^{30} \text{ s}^{-1}$
8.  ${}_{13}^{27}\text{Al}$  is a stable isotope,  ${}_{13}^{29}\text{Al}$  is expected to disintegrate by (1996 - 1 Mark)  
 (a)  $\alpha$ -emission (b)  $\beta$ -emission  
 (c) positron emission (d) proton emission
9. The number of neutrons accompanying the formation of  ${}_{54}^{139}\text{Xe}$  and  ${}_{38}^{94}\text{Sr}$  from the absorption of a slow neutron by  ${}_{92}^{235}\text{U}$ , followed by nuclear fission is, (1999 - 2 Marks)  
 (a) 0 (b) 2  
 (c) 1 (d) 3
10. The rate constant for the reaction,  $2\text{N}_2\text{O}_5 \rightarrow 4\text{NO}_2 + \text{O}_2$ , is  $3.0 \times 10^{-5} \text{ sec}^{-1}$ . If the rate is  $2.40 \times 10^{-5} \text{ mol litre}^{-1} \text{ sec}^{-1}$ , then the concentration of  $\text{N}_2\text{O}_5$  (in  $\text{mol litre}^{-1}$ ) is (2000S)  
 (a) 1.4 (b) 1.2  
 (c) 0.04 (d) 0.8
11. If ' $I$ ' is the intensity of absorbed light and ' $C$ ' is the concentration of  $AB$  for the photochemical process,  $AB + h\nu \rightarrow AB^*$ , the rate of formation of  $AB^*$  is directly proportional to (2001S)  
 (a)  $C$  (b)  $I$   
 (c)  $I^2$  (d)  $C \cdot I$
12. Consider the chemical reaction,  $\text{N}_2(\text{g}) + 3\text{H}_2(\text{g}) \rightarrow 2\text{NH}_3(\text{g})$ . The rate of this reaction can be expressed in terms of time derivative of concentration of  $\text{N}_2(\text{g})$ ,  $\text{H}_2(\text{g})$  or  $\text{NH}_3(\text{g})$ . Identify the correct relationship amongst the rate expressions. (2002S)  
 (a)  $\text{Rate} = -d[\text{N}_2]/dt = -1/3d[\text{H}_2]/dt = 1/2d[\text{NH}_3]/dt$   
 (b)  $\text{Rate} = -d[\text{N}_2]/dt = -3d[\text{H}_2]/dt = 2d[\text{NH}_3]/dt$   
 (c)  $\text{Rate} = d[\text{N}_2]/dt = 1/3d[\text{H}_2]/dt = 1/2d[\text{NH}_3]/dt$   
 (d)  $\text{Rate} = -d[\text{N}_2]/dt = -d[\text{H}_2]/dt = d[\text{NH}_3]/dt$
13. In a first order reaction the concentration of reactant decreases from  $800 \text{ mol/dm}^3$  to  $50 \text{ mol/dm}^3$  in  $2 \times 10^4 \text{ sec}$ . The rate constant of reaction in  $\text{sec}^{-1}$  is: (2003S)  
 (a)  $2 \times 10^4$  (b)  $3.45 \times 10^{-5}$   
 (c)  $1.386 \times 10^{-4}$  (d)  $2 \times 10^{-4}$
14.  ${}^{23}\text{Na}$  is the more stable isotope of Na. Find out the process by which  ${}^{24}_{11}\text{Na}$  can undergo radioactive decay (2003S)  
 (a)  $\beta^-$  emission (b)  $\alpha$  emission  
 (c)  $\beta^+$  emission (d) K electron capture
15. The reaction,  $A \rightarrow \text{Product}$ , follows first order kinetics. In 40 minutes the concentration of A changes from 0.1 to 0.025 M. The rate of reaction, when concentration of A is 0.01 M is (2004S)  
 (a)  $1.73 \times 10^{-4} \text{ M min}^{-1}$  (b)  $3.47 \times 10^{-5} \text{ M min}^{-1}$   
 (c)  $3.47 \times 10^{-4} \text{ M min}^{-1}$  (d)  $1.73 \times 10^{-5} \text{ M min}^{-1}$
16. Which one of the following statement for order of reaction is not correct? (2005S)  
 (a) Order can be determined experimentally  
 (b) Order of reaction is equal to sum of the powers of concentration terms in differential rate law.  
 (c) It is not affected with the stoichiometric coefficient of the reactants  
 (d) Order cannot be fractional.
17.  $\text{Ag}^+ + \text{NH}_3 \rightleftharpoons [\text{Ag}(\text{NH}_3)]^+$ ;  $k_1 = 6.8 \times 10^{-3}$   
 $[\text{Ag}(\text{NH}_3)]^+ + \text{NH}_3 \rightleftharpoons [\text{Ag}(\text{NH}_3)_2]^+$ ;  $k_2 = 1.6 \times 10^{-3}$   
 then the formation constant of  $[\text{Ag}(\text{NH}_3)_2]^+$  is (2006 - 3M, -1)  
 (a)  $6.8 \times 10^{-6}$  (b)  $1.08 \times 10^{-5}$   
 (c)  $1.08 \times 10^{-6}$  (d)  $6.8 \times 10^{-5}$
18. Consider a reaction  $aG + bH \rightarrow \text{Products}$ . When concentration of both the reactants  $G$  and  $H$  is doubled, the rate increases by eight times. However, when concentration of  $G$  is doubled keeping the concentration of  $H$  fixed, the rate is doubled. The overall order of the reaction is (2007)  
 (a) 0 (b) 1  
 (c) 2 (d) 3
19. A positron is emitted from  ${}_{11}^{23}\text{Na}$ . The ratio of the atomic mass and atomic number of the resulting nuclide is (2007)  
 (a) 22/10 (b) 22/11  
 (c) 23/10 (d) 23/12
20. Under the same reaction conditions, initial concentration of  $1.386 \text{ mol dm}^{-3}$  of a substance becomes half in 40 seconds and 20 seconds through first order and zero order kinetics, respectively. Ratio ( $k_1/k_0$ ) of the rate constant for first order ( $k_1$ ) and zero order ( $k_0$ ) of the reaction is - (2008)  
 (a)  $0.5 \text{ mol}^{-1} \text{ dm}^3$  (b)  $1.0 \text{ mol dm}^{-3}$   
 (c)  $1.5 \text{ mol dm}^{-3}$  (d)  $2.0 \text{ mol}^{-1} \text{ dm}^3$
21. For a first order reaction  $A \rightarrow P$ , the temperature ( $T$ ) dependent rate constant ( $k$ ) was found to follow the equation  $\log k = - (2000) \frac{1}{T} + 6.0$ . The pre-exponential factor  $A$  and the activation energy  $E_a$ , respectively, are (2009)  
 (a)  $1.0 \times 10^6 \text{ s}^{-1}$  and  $9.2 \text{ kJ mol}^{-1}$   
 (b)  $6.0 \text{ s}^{-1}$  and  $16.6 \text{ kJ mol}^{-1}$   
 (c)  $1.0 \times 10^6 \text{ s}^{-1}$  and  $16.6 \text{ kJ mol}^{-1}$   
 (d)  $1.0 \times 10^6 \text{ s}^{-1}$  and  $38.3 \text{ kJ mol}^{-1}$
22. Plots showing the variation of the rate constant ( $k$ ) with temperature ( $T$ ) are given below. The plot that follows Arrhenius equation is (2010)

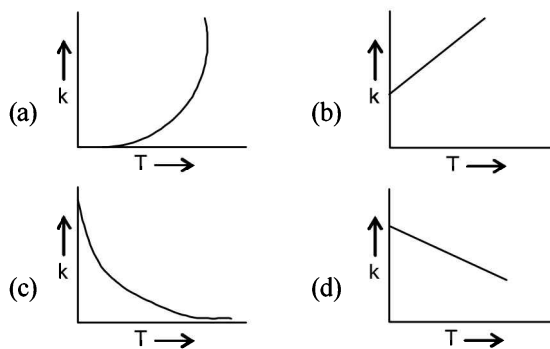

23. Bombardment of aluminium by  $\alpha$ -particle leads to its artificial disintegration in two ways, (i) and (ii) as shown. Products X, Y and Z respectively are, (2011)

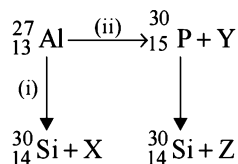

- (a) proton, neutron, positron  
 (b) neutron, positron, proton  
 (d) proton, positron, neutron  
 (d) positron, proton, neutron
24. In the reaction,  
 $\text{P} + \text{Q} \longrightarrow \text{R} + \text{S}$   
 The time taken for 75% reaction of P is twice the time taken for 50% reaction of P. The concentration of Q varies with reaction time as shown in the figure. The overall order of the reaction is (JEE Adv. 2013)

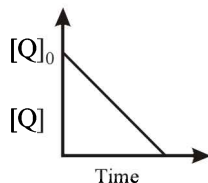

- (a) 2 (b) 3  
 (c) 0 (d) 1
25. For the elementary reaction  $\text{M} \rightarrow \text{N}$ , the rate of disappearance of M increases by a factor of 8 upon doubling the concentration of M. The order of the reaction with respect to M is (JEE Adv. 2014)
- (a) 4 (b) 3  
 (c) 2 (d) 1

### D MCQs with One or More Than One Correct

1. A catalyst : (1984 - 1 Mark)  
 (a) increases the average kinetic energy of reacting molecules  
 (b) decreases the activation energy  
 (c) alters the reaction mechanism  
 (d) increases the frequency of collisions of reacting species
2. The rate law for the reaction : (1988 - 1 Mark)  
 $\text{RCl} + \text{NaOH}(\text{aq.}) \rightarrow \text{ROH} + \text{NaCl}$   
 is given by, Rate =  $k_1 [\text{RCl}]$ . The rate of the reaction will be  
 (a) doubled on doubling the concentration of sodium hydroxide.  
 (b) halved on reducing the concentration of alkyl halide to one half.  
 (c) increased on increasing the temperature of the reaction.  
 (d) unaffected by increasing the temperature of the reaction.
3. Nuclear reactions accompanied with emission of neutron(s) are : (1988 - 1 Mark)  
 (a)  ${}^{17}_{13}\text{Al} + {}^4_2\text{H} \rightarrow {}^{30}_{15}\text{P}$   
 (b)  ${}^{12}_6\text{C} + {}^1_1\text{H} \rightarrow {}^{13}_7\text{N}$   
 (c)  ${}^{30}_{15}\text{P} \rightarrow {}^{30}_{14}\text{Si} + {}^0_1\text{e}$   
 (d)  ${}^{241}_{96}\text{Am} + {}^4_2\text{He} \rightarrow {}^{244}_{97}\text{Bk} + {}^0_1\text{e}$
4. For a first order reaction, (1998 - 2 Marks)  
 (a) the degree of dissociation is equal to  $(1 - e^{-kt})$   
 (b) a plot of reciprocal concentration of the reactant vs time gives a straight line.  
 (c) the time taken for the completion of 75% reaction is thrice the  $t_{1/2}$  of the reaction  
 (d) the pre-exponential factor in the Arrhenius equation has the dimension of time,  $T^{-1}$ .
5. The following statement(s) is (are) correct : (1999 - 3 Marks)  
 (a) A plot of  $\log K_p$  versus  $1/T$  is linear  
 (b) A plot of  $\log [X]$  versus time is linear for a first order reaction,  $X \rightarrow P$   
 (c) A plot of  $P$  versus  $1/T$  is linear at constant volume  
 (d) A plot of  $P$  versus  $1/V$  is linear at constant
6. For the first order reaction (2011)  
 $2\text{N}_2\text{O}_5(\text{g}) \rightarrow 4\text{NO}_2(\text{g}) + \text{O}_2(\text{g})$   
 (a) the concentration of the reactant decreases exponentially with time  
 (b) the half-life of the reaction decreases with increasing temperature  
 (c) the half-life of the reaction depends on the initial concentration of the reactant  
 (d) the reaction proceeds to 99.6% completion in eight half-life duration
7. In the nuclear transmutation (JEE Adv. 2013)  
 ${}^9_4\text{Be} + \text{X} \longrightarrow {}^8_4\text{Be} + \text{Y}$   
 (X, Y) is(are)  
 (a) ( $\gamma$ , n) (b) (p, D)  
 (c) (n, D) (d) ( $\gamma$ , p)
8. According to the Arrhenius equation, (JEE Adv. 2016)  
 (a) a high activation energy usually implies a fast reaction.  
 (b) rate constant increases with increase in temperature. This is due to a greater number of collisions whose energy exceeds the activation energy.  
 (c) higher the magnitude of activation energy, stronger is the temperature dependence of the rate constant.  
 (d) the pre-exponential factor is a measure of the rate at which collisions occur, irrespective of their energy.
9. A plot of the number of neutrons (N) against the number of protons (P) of stable nuclei exhibits upward deviation from linearity for atomic number,  $Z > 20$ . For an unstable nucleus having N/P ratio less than 1, the possible mode(s) of decay is(are) (JEE Adv. 2016)  
 (a)  $\beta^-$ -decay ( $\beta$  emission)  
 (b) orbital or K-electron capture  
 (c) neutron emission  
 (d)  $\beta^-$ -decay (positron emission)

## E Subjective Problems

1. Rate of a reaction  $A + B \rightarrow$  products, is given below as a function of different initial concentrations of  $A$  and  $B$  :

(1982 - 4 Marks)

[A] (mol/l)	[B] (mol/l)	Initial rate (mol/l/min)
0.01	0.01	0.005
0.02	0.01	0.010
0.01	0.02	0.005

Determine the order of the reaction with respect to  $A$  and with respect to  $B$ . What is the half-life of  $A$  in the reaction?

2. Radioactive decay is a first order process. Radioactive carbon in wood sample decays with a half life of 5770 years. What is the rate constant (in  $\text{years}^{-1}$ ) for the decay? What fraction would remain after 11540 years? (1984 - 3 Marks)
3. While studying the decomposition of gaseous  $\text{N}_2\text{O}_5$  it is observed that a plot of logarithm of its partial pressure versus time is linear. What kinetic parameters can be obtained from this observation? (1985 - 2 Marks)
4.  ${}^{234}_{90}\text{Th}$  disintegrates to give  ${}^{206}_{82}\text{Pb}$  as the final product.

How many alpha and beta particles are emitted during this process? (1986 - 2 Marks)

5. A first order reaction has  $K = 1.5 \times 10^{-6}$  per second at  $200^\circ\text{C}$ . If the reaction is allowed to run for 10 hours, what percentage of the initial concentration would have changed in the product? What is the half life of this reaction? (1987 - 5 Marks)

6. A first order reaction is 50% complete in 30 minutes at  $27^\circ\text{C}$  and in 10 minutes at  $47^\circ\text{C}$ . Calculate the reaction rate constant at  $27^\circ\text{C}$  and the energy of activation of the reaction in kJ/mole. (1988 - 3 Marks)

7. An experiment requires minimum beta activity product at the rate of 346 beta particles per minute. The half life period of  ${}^{99}_{42}\text{Mo}$ , which is a beta emitter is 66.6 hours. Find the

minimum amount of  ${}^{99}_{42}\text{Mo}$  required to carry out the experiment in 6.909 hours. (1989 - 5 Marks)

8. In the Arrhenius equation for a certain reaction, the value of  $A$  and  $E_a$  (activation energy) are  $4 \times 10^{13} \text{ sec}^{-1}$  and  $98.6 \text{ kJ mol}^{-1}$  respectively. If the reaction is of first order, at what temperature will its half-life period be ten minutes? (1990 - 3 Marks)

9. The decomposition of  $\text{N}_2\text{O}_5$  according to the equation :

(1991 - 6 Marks)



is a first order reaction. After 30 min. from the start of the decomposition in a closed vessel, the total pressure developed is found to be 284.5 mm of Hg and on complete decomposition, the total pressure is 584.5 mm of Hg. Calculate the rate constant of the reaction.

10. Two reactions (i)  $A \rightarrow$  products, (ii)  $B \rightarrow$  products, follows first order kinetics. The rate of the reaction : (i) is doubled when the temperature is raised from 300K to 310K. The half life for this reaction at 310K is 30 minutes. At the same

temperature  $B$  decomposes twice as fast as  $A$ . If the energy of activation for the reaction, (ii) is half that of reaction (i), calculate the rate constant of the reaction (ii) at 300K.

(1992 - 3 Marks)

11. The nucleic ratio,  ${}^3_1\text{H}$  to  ${}^1_1\text{H}$  in a sample of water is  $8.0 \times 10^{-18} : 1$ . Tritium undergoes decay with a half life period of 12.3 years. How many tritium atoms would 10.0 g of such a sample contain 40 years after the original sample is collected? (1992 - 4 Marks)

12. A first order reaction  $A \rightarrow B$ , requires activation energy of  $70 \text{ kJ mol}^{-1}$ . When a 20% solution of  $A$  was kept at  $25^\circ\text{C}$  for 20 minutes, 25% decomposition took place. What will be the percent decomposition in the same time in a 30% solution maintained at  $40^\circ\text{C}$ ? Assume that activation energy remains constant in this range of temperature. (1993 - 4 Marks)

13. The gas phase decomposition of dimethyl ether follows first order kinetics.

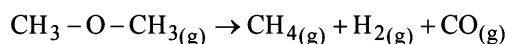

The reaction is carried out in a constant volume container at  $500^\circ\text{C}$  and has a half life of 14.5 minutes. Initially, only dimethyl ether is present at a pressure of 0.40 atmosphere. What is the total pressure of the system after 12 minutes? Assume ideal gas behaviour. (1993 - 4 Marks)

14. The progress of the reaction,  $A \rightleftharpoons nB$ , with time, is presented in figure given below. Determine

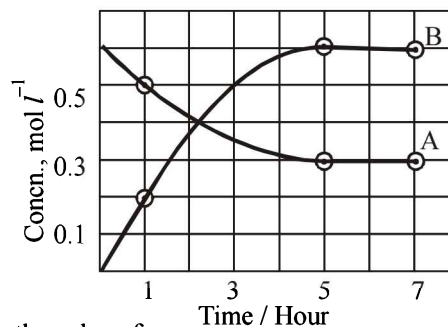

- (i) the value of  $n$   
 (ii) the equilibrium constant,  $K$  and  
 (iii) the initial rate of conversion of  $A$ . (1994 - 3 Marks)

15. From the following data for the reaction between  $A$  and  $B$ . (1994 - 5 Marks)

	[A], mol lit <sup>-1</sup>	[B], mol lit <sup>-1</sup>	Initial rate mole lit <sup>-1</sup> s <sup>-1</sup> at	
			300 K	320 K
I	$2.5 \times 10^{-4}$	$3.0 \times 10^{-5}$	$5.0 \times 10^{-4}$	$2.0 \times 10^{-3}$
II	$5.0 \times 10^{-4}$	$6.0 \times 10^{-5}$	$4.0 \times 10^{-3}$	—
III	$1.0 \times 10^{-3}$	$6.0 \times 10^{-5}$	$1.6 \times 10^{-2}$	—

Calculate

- (i) the order of the reaction with respect to  $A$  and with respect to  $B$ ,  
 (ii) the rate constant at 300K  
 (iii) the energy of activation, and  
 (iv) the pre-exponential factor
16. One of the hazards of nuclear explosion is the generation of  ${}^{90}\text{Sr}$  and its subsequent incorporation in bones. This

- nuclide has a half-life of 28.1 years. Suppose one microgram was absorbed by a new-born child, how much  $^{90}\text{Sr}$  will remain in his bones after 20 years? (1995 - 2 Marks)
17. At  $380^\circ\text{C}$ , the half-life period for the first order decomposition of  $\text{H}_2\text{O}_2$  is 360 min. The energy of activation of the reaction is  $200 \text{ kJ mol}^{-1}$ . Calculate the time required for 75% decomposition at  $450^\circ\text{C}$ . (1995 - 4 Marks)
18.  $^{227}\text{Ac}$  has a half-life of 21.8 years with respect to radioactive decay. The decay follows two parallel paths, one leading to  $^{227}\text{Th}$  and the other to  $^{223}\text{Fr}$ . The percentage yields of these two daughter nuclides are 1.2 and 98.8 respectively. What are the decay constants ( $\lambda$ ) for each of the separate paths? (1996 - 2 Marks)
19. The ionisation constant of  $\text{NH}_4^+$  in water is  $5.6 \times 10^{-10}$  at  $25^\circ\text{C}$ . The rate constant for the reaction of  $\text{NH}_4^+$  and  $\text{OH}^-$  to form  $\text{NH}_3$  and  $\text{H}_2\text{O}$  at  $25^\circ\text{C}$  is  $3.4 \times 10^{10} \text{ L mol}^{-1} \text{ s}^{-1}$ . Calculate the rate constant for proton transfer from water to  $\text{NH}_3$ . (1996 - 3 Marks)
20. The rate constant for the first order decomposition of a certain reaction is described by the equation
- $$\log(K) = 14.34 - \frac{1.25 \times 10^4 K}{T} \quad (1997 - 5 \text{ Marks})$$
- (i) What is the energy of activation for this reaction?  
(ii) At what temperature will its half-life period be 256 minutes?
21. Write a balanced equation for the reaction of  $^{14}\text{N}$  with  $\alpha$ -particle. (1997 - 1 Mark)
22. The rate constant of a reaction is  $1.5 \times 10^7 \text{ s}^{-1}$  at  $50^\circ\text{C}$  and  $4.5 \times 10^7 \text{ s}^{-1}$  at  $100^\circ\text{C}$ . Evaluate the Arrhenius parameters  $A$  and  $E_a$ . (1998 - 5 Marks)
23. The rate constant for an isomerisation reaction,  $A \rightarrow B$  is  $4.5 \times 10^{-3} \text{ min}^{-1}$ . If the initial concentration of  $A$  is 1 M, calculate the rate of the reaction after 1 h. (1999 - 4 Marks)
24.  $^{238}_{92}\text{U}$  is radioactive and it emits  $\alpha$  and  $\beta$  particles to form  $^{206}_{82}\text{Pb}$ . Calculate the number of  $\alpha$  and  $\beta$  particles emitted in this conversion. An ore of  $^{238}_{92}\text{U}$  is found to contain  $^{238}_{92}\text{U}$  and  $^{206}_{82}\text{Pb}$  in the weight ratio of 1:0.1. The half-life period of  $^{238}_{92}\text{U}$  is  $4.5 \times 10^9$  years. Calculate the age of the ore. (2000 - 5 Marks)
25. A hydrogenation reaction is carried out at 500 K. If same reaction is carried out in the presence of a catalyst at the same rate, the temperature required is 400 K. Calculate the activation energy of the reaction if the catalyst lowers the activation barrier by  $20 \text{ kJ mol}^{-1}$ . (2000 - 3 Marks)
26. The rate of a first-order reaction is  $0.04 \text{ mol litre}^{-1} \text{ s}^{-1}$  at 10 minutes and  $0.03 \text{ mol litre}^{-1} \text{ s}^{-1}$  at 20 minutes after initiation. Find the half-life of the reaction. (2001 - 5 Marks)
27. The vapour pressure of the two miscible liquids (A) and (B) are 300 and 500 mm of Hg respectively. In a flask 10 moles of (A) is mixed with 12 moles of (B). However, as soon as (B) is added, (A) starts polymerizing into a completely insoluble solid. The polymerization follows first-order kinetics. After 100 minutes, 0.525 mole of a solute is dissolved which arrests the polymerization completely. The final vapour pressure of the solution is 400 mm of Hg. Estimate the rate of constant of the polymerization reaction. Assume negligible volume change on mixing and polymerization and ideal behaviour for the final solution. (2001 - 10 Marks)
28.  $^{64}\text{Cu}$  (half-life = 12.8 h) decays by  $\beta^-$  emission (38%),  $\beta^+$  emission (19%) and electron capture (43%). Write the decay products and calculate partial half-lives for each of the decay processes. (2002 - 5 Marks)
29. For the given reactions,  $A + B \rightarrow \text{Products}$ , following data were obtained. (2004 - 2 Marks)
- |    | $[A_0]$ | $[B_0]$ | $R_0 (\text{mol L}^{-1} \text{ s}^{-1})$ |
|----|---------|---------|--|
| 1. | 0.1     | 0.2     | 0.05                                     |
| 2. | 0.2     | 0.2     | 0.10                                     |
| 3. | 0.1     | 0.1     | 0.05                                     |
- (a) Write the rate law expression  
(b) Find the rate constant
30. Complete and balance the following reactions.
- (i)  $^{92}\text{Th}^{234} \longrightarrow \dots + 7 \text{ } ^2_2\text{He}^4 + 6 \text{ } ^{-1}_0\text{e}^0$  (2004 - 1 Mark)
- (ii)  $^{92}\text{U}^{235} + \text{}^1_0\text{n}^1 \longrightarrow \dots + \text{}^{52}\text{Te}^{137} + \text{}^{40}\text{Zr}^{92}$  (2005 - 1 Mark)
- (iii)  $^{34}\text{Se}^{86} \longrightarrow 2 \text{ } ^{-1}_1\text{e}^0 + \dots$  (2005 - 1 Mark)
31. At constant temperature and volume,  $X$  decomposes as (2005 - 4 Marks)
- $$2X(\text{g}) \longrightarrow 3Y(\text{g}) + 2Z(\text{g}); P_x \text{ is the partial pressure of } X.$$
- | Observation No. | Time (in minute) | $P_x$ (in mm of Hg) |
|-----------------|------------------|---------------------|
| 1               | 0                | 800                 |
| 2               | 100              | 400                 |
| 3               | 200              | 200                 |
- (i) What is the order of reaction with respect to  $X$ ?  
(ii) Find the rate constant.  
(iii) Find the time for 75% completion of the reaction.  
(iv) Find the total pressure when pressure of  $X$  is 700 mm of Hg.

## G Comprehension Based Questions

Several short-lived radioactive species have been used to determine the age of wood or animal fossils. One of the most interesting substances is  $^{14}_6\text{C}$  (half-life 5760 years) which is used in determining the age of carbon-bearing materials (e.g. wood, animal fossils, etc.). Carbon-14 is produced by the bombardment of nitrogen atoms present in the upper atmosphere with neutrons (from cosmic rays).

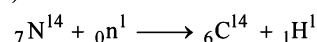

Thus carbon-14 is oxidised to  $\text{CO}_2$  and eventually ingested by plants and animals. The death of plants or animals put an end to the intake of  $\text{C}^{14}$  from the atmosphere. After this the amount of  $\text{C}^{14}$  in the dead tissues starts decreasing due to its disintegration as per the following reaction :

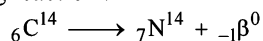

The  $\text{C}^{14}$  isotope enters the biosphere when carbon dioxide is taken up in plant photosynthesis. Plants are eaten by animals, which exhale  $\text{C}^{14}$  as  $\text{CO}_2$ . Eventually,  $\text{C}^{14}$  participates in many aspects of the carbon cycle. The  $\text{C}^{14}$  lost by radioactive decay is constantly replenished by the production of new isotopes in the atmosphere. In this decay-replenishment process, a dynamic equilibrium is established whereby the ratio of  $\text{C}^{14}$  to  $\text{C}^{12}$  remains constant in living matter. But when an individual plant or an animal dies, the  $\text{C}^{14}$  isotope in it is no longer replenished, so the ratio decreases as  $\text{C}^{14}$  decays. So, the number of  $\text{C}^{14}$  nuclei after time  $t$  (after the death of living matter) would be less than in a living matter. The decay constant can be calculated using the following formula,

$$t_{1/2} = \frac{0.693}{\lambda}$$

The intensity of the cosmic rays have remain the same for 30,000 years. But since some years the changes in this are observed due to excessive burning of fossil fuel and nuclear tests.

- Why do we use the carbon dating to calculate the age of the fossil? (2006 - 5M, -2)
  - Rate of exchange of carbon between atmosphere and living is slower than decay of  $\text{C}^{14}$
  - It is not appropriate to use  $\text{C}^{14}$  dating to determine age
  - Rate of exchange of  $\text{C}^{14}$  between atmosphere and living organism is so fast that an equilibrium is set up between the intake of  $\text{C}^{14}$  by organism and its exponential decay
  - none of the above
- What should be the age of the fossil for meaningful determination of its age? (2006 - 5M, -2)
  - 6 years
  - 6000 years
  - 60,000 years
  - can be used to calculate any age
- A nuclear explosion has taken place leading to increase in concentration of  $\text{C}^{14}$  in nearby areas.  $\text{C}^{14}$  concentration is  $C_1$  in nearby areas and  $C_2$  in areas far away. If the age of the fossil is determined to be  $T_1$  and  $T_2$  at the respective places then (2006 - 5M, -2)
  - The age of the fossil will increase at the place where explosion has taken place and  $T_1 - T_2 = \frac{1}{\lambda} \ln \frac{C_1}{C_2}$
  - The age of the fossil will decrease at the place where explosion has taken place and  $T_1 - T_2 = \frac{1}{\lambda} \ln \frac{C_1}{C_2}$
  - The age of fossil will be determined to be same
  - $\frac{T_1}{T_2} = \frac{C_1}{C_2}$

## H Assertion & Reason Type Questions

- Read the following assertion and statement and answer as per the options given below :
 

**Assertion :** For each ten degree rise of temperature the specific rate constant is nearly doubled.

**Statement :** Energy-wise distribution of molecules in a gas is an experimental function of temperature.

(1989 - 2 Marks)

  - If both assertion and statement are correct and statement is an explanation of assertion.
  - If assertion is correct and statement is wrong, statement is not an explanation of assertion.
  - If assertion is wrong and statement is correct, statement is not an explanation of assertion.
  - If both assertion and statement are wrong and statement is not explanation of assertion.

## I Integer Value Correct Type

- The total number of  $\alpha$  and  $\beta$  particles emitted in the nuclear reaction  ${}_{92}^{238}\text{U} \rightarrow {}_{82}^{214}\text{Pb}$  is (2009)
- The concentration of R in the reaction  $\text{R} \rightarrow \text{P}$  was measured as a function of time and the following data is obtained:
 

[R] (molar)	1.0	0.75	0.40	0.10
t (min.)	0.0	0.05	0.12	0.18

The order of reaction is (2010)
- The number of neutrons emitted when  ${}_{92}^{235}\text{U}$  undergoes controlled nuclear fission to  ${}_{54}^{142}\text{Xe}$  and  ${}_{38}^{90}\text{Sr}$  is (2010)
- An organic compound undergoes first-order decomposition. The time taken for its decomposition to 1/8 and 1/10 of its initial concentration are  $t_{1/8}$  and  $t_{1/10}$  respectively. What is the value of  $\left[ \frac{t_{1/8}}{t_{1/10}} \right] \times 10$ ? ( $\log_{10} 2 = 0.3$ ) (2012)
- The periodic table consists of 18 groups. An isotope of copper, on bombardment with protons, undergoes a nuclear reaction yielding element X as shown below. To which group, element X belongs in the periodic table? (2012)
 
$${}_{29}^{63}\text{Cu} + {}_1^1\text{H} \rightarrow {}_0^1n + {}_2^4\alpha + {}_1^2\text{H} + \text{X}$$
- A closed vessel with rigid walls contains 1 mol of  ${}_{92}^{238}\text{U}$  and 1 mol of air at 298 K. Considering complete decay of  ${}_{92}^{238}\text{U}$  to  ${}_{82}^{206}\text{Pb}$ , the ratio of the final pressure to the initial pressure of the system at 298 K is (JEE Adv. 2015)
- In dilute aqueous  $\text{H}_2\text{SO}_4$ , the complex diaquodioxalatoferate(II) is oxidized by  $\text{MnO}_4^-$ . For this reaction, the ratio of the rate of change of  $[\text{H}^+]$  to the rate of change of



## Section-B

## JEE Main / AIEEE

- Units of rate constant of first and zero order reactions in terms of molarity M unit are respectively [2002]
  - $\text{sec}^{-1}$ ,  $\text{Msec}^{-1}$
  - $\text{sec}^{-1}$ , M
  - $\text{Msec}^{-1}$ ,  $\text{sec}^{-1}$
  - M,  $\text{sec}^{-1}$ .
- For the reaction  $A + 2B \rightarrow C$ , rate is given by  $R = [A][B]^2$  then the order of the reaction is [2002]
  - 3
  - 6
  - 5
  - 7.
- The differential rate law for the reaction [2002]
 
$$\text{H}_2 + \text{I}_2 \rightarrow 2\text{HI}$$
  - $-\frac{d[\text{H}_2]}{dt} = -\frac{d[\text{I}_2]}{dt} = -\frac{d[\text{HI}]}{dt}$
  - $\frac{d[\text{H}_2]}{dt} = \frac{d[\text{I}_2]}{dt} = \frac{1}{2} \frac{d[\text{HI}]}{dt}$
  - $\frac{1}{2} \frac{d[\text{H}_2]}{dt} = \frac{1}{2} \frac{d[\text{I}_2]}{dt} = -\frac{d[\text{HI}]}{dt}$
  - $-2 \frac{d[\text{H}_2]}{dt} = -2 \frac{d[\text{I}_2]}{dt} = \frac{d[\text{HI}]}{dt}$
- If half-life of a substance is 5 yrs, then the total amount of substance left after 15 years, when initial amount is 64 grams is
  - 16 grams
  - 2 grams
  - 32 grams
  - 8 grams. [2002]
- The integrated rate equation is [2002]
 
$$Rt = \log C_0 - \log C_t$$
 The straight line graph is obtained by plotting
  - time vs  $\log C_t$
  - $\frac{1}{\text{time}}$  vs  $C_t$
  - time vs  $C_t$
  - $\frac{1}{\text{time}}$  vs  $\frac{1}{C_t}$
- $\beta$ -particle is emitted in radioactivity by [2002]
  - conversion of proton to neutron
  - from outermost orbit
  - conversion of neutron to proton
  - $\beta$ -particle is not emitted.
- The radionuclide  ${}_{90}^{234}\text{Th}$  undergoes two successive  $\beta$ -decays followed by one  $\alpha$ -decay. The atomic number and the mass number respectively of the resulting radionuclide are [2003]
  - 94 and 230
  - 90 and 230
  - 92 and 230
  - 92 and 234
- The half-life of a radioactive isotope is three hours. If the initial mass of the isotope were 256 g, the mass of it remaining undecayed after 18 hours would be [2003]
  - 8.0 g
  - 12.0 g
  - 16.0 g
  - 4.0 g
- In respect of the equation  $k = A e^{-E_a/RT}$  in chemical kinetics, which one of the following statements is correct? [2003]
  - A is adsorption factor
  - $E_a$  is energy of activation
  - R is Rydberg's constant
  - k is equilibrium constant
- The rate law for a reaction between the substances A and B is given by
 
$$\text{Rate} = k [\text{A}]^n [\text{B}]^m$$
 On doubling the concentration of A and halving the concentration of B, the ratio of the new rate to the earlier rate of the reaction will be as [2003]
  - $(m+n)$
  - $(n-m)$
  - $2^{(n-m)}$
  - $\frac{1}{2^{(m+n)}}$
- For the reaction system : [2003]
 
$$2\text{NO}(\text{g}) + \text{O}_2(\text{g}) \rightarrow 2\text{NO}_2(\text{g})$$
 volume is suddenly reduced to half its value by increasing the pressure on it. If the reaction is of first order with respect to  $\text{O}_2$  and second order with respect to NO, the rate of reaction will
  - diminish to one-eighth of its initial value
  - increase to eight times of its initial value
  - increase to four times of its initial value
  - diminish to one-fourth of its initial value
- In a first order reaction, the concentration of the reactant, decreases from 0.8 M to 0.4 M in 15 minutes. The time taken for the concentration to change from 0.1 M to 0.025 M is
  - 7.5 minutes
  - 15 minutes
  - 30 minutes
  - 60 minutes [2004]
- The rate equation for the reaction  $2\text{A} + \text{B} \rightarrow \text{C}$  is found to be : rate =  $k[\text{A}][\text{B}]$ . The correct statement in relation to this reaction is that the [2004]
  - rate of formation of C is twice the rate of disappearance of A
  - $t_{1/2}$  is a constant
  - unit of k must be  $\text{s}^{-1}$
  - value of k is independent of the initial concentrations of A and B

14. Consider the following nuclear reactions : [2004]

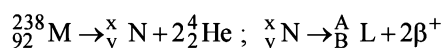

The number of neutrons in the element L is

- (a) 140 (b) 144  
(c) 142 (d) 146
15. The half-life of a radioisotope is four hours. If the initial mass of the isotope was 200 g, the mass remaining after 24 hours undecayed is [2004]
- (a) 3.125 g (b) 2.084 g  
(c) 1.042 g (d) 4.167 g
16. Hydrogen bomb is based on the principle of [2005]
- (a) artificial radioactivity  
(b) nuclear fusion  
(c) natural radioactivity  
(d) nuclear fission
17. A reaction involving two different reactants can never be [2005]
- (a) bimolecular reaction  
(b) second order reaction  
(c) first order reaction  
(d) unimolecular reaction
18. A schematic plot of  $\ln K_{eq}$  versus inverse of temperature for a reaction is shown below [2005]

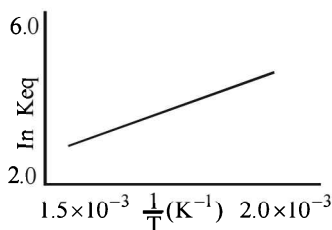

The reaction must be

- (a) highly spontaneous at ordinary temperature  
(b) one with negligible enthalpy change  
(c) endothermic  
(d) exothermic
19. A photon of hard gamma radiation knocks a proton out of  ${}_{12}^{24}\text{Mg}$  nucleus to form [2005]
- (a) the isobar of  ${}_{11}^{23}\text{Na}$   
(b) the nuclide  ${}_{11}^{23}\text{Na}$   
(c) the isobar of parent nucleus  
(d) the isotope of parent nucleus

20.  $t_{1/4}$  can be taken as the time taken for the concentration of a reactant to drop to  $\frac{3}{4}$  of its initial value. If the rate constant

for a first order reaction is  $K$ , the  $t_{1/4}$  can be written as

- (a)  $0.75/K$  (b)  $0.69/K$  [2005]  
(c)  $0.29/K$  (d)  $0.10/K$
21. A reaction was found to be second order with respect to the concentration of carbon monoxide. If the concentration of carbon monoxide is doubled, with everything else kept the same, the rate of reaction will [2006]
- (a) increase by a factor of 4  
(b) double  
(c) remain unchanged  
(d) triple
22. Rate of a reaction can be expressed by Arrhenius equation as : [2006]

$$k = A e^{-E/RT}$$

In this equation,  $E$  represents

- (a) the total energy of the reacting molecules at a temperature,  $T$   
(b) the fraction of molecules with energy greater than the activation energy of the reaction  
(c) the energy above which all the colliding molecules will react  
(d) the energy below which all the colliding molecules will react
23. In the transformation of  ${}_{92}^{238}\text{U}$  to  ${}_{92}^{234}\text{U}$ , if one emission is an  $\alpha$ -particle, what should be the other emission(s)? [2006]
- (a) one  $\beta^-$  and one  $\gamma$  (b) one  $\beta^+$  and one  $\beta^-$   
(c) two  $\beta^-$  (d) two  $\beta^-$  and one  $\beta^+$
24. The following mechanism has been proposed for the reaction of  $\text{NO}$  with  $\text{Br}_2$  to form  $\text{NOBr}$  :

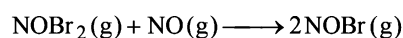
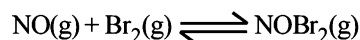

If the second step is the rate determining step, the order of the reaction with respect to  $\text{NO}(\text{g})$  is [2006]

- (a) 3 (b) 2  
(c) 1 (d) 0
25. The energies of activation for forward and reverse reactions for  $\text{A}_2 + \text{B}_2 \rightleftharpoons 2\text{AB}$  are  $180 \text{ kJ mol}^{-1}$  and  $200 \text{ kJ mol}^{-1}$  respectively. The presence of a catalyst lowers the activation energy of both (forward and reverse) reactions by  $100 \text{ kJ mol}^{-1}$ . The enthalpy change of the reaction ( $\text{A}_2 + \text{B}_2 \rightarrow 2\text{AB}$ ) in the presence of a catalyst will be (in  $\text{kJ mol}^{-1}$ ) [2007]

- (a) 20 (b) 300  
(c) 120 (d) 280
26. Consider the reaction,  $2A + B \rightarrow$  products. When concentration of B alone was doubled, the half-life did not change. When the concentration of A alone was doubled, the rate increased by two times. The unit of rate constant for this reaction is [2007]  
(a)  $s^{-1}$  (b)  $L mol^{-1} s^{-1}$   
(c) no unit (d)  $mol L^{-1} s^{-1}$ .
27. A radioactive element gets spilled over the floor of a room. Its half-life period is 30 days. If the initial velocity is ten times the permissible value, after how many days will it be safe to enter the room? [2007]  
(a) 100 days (b) 1000 days  
(c) 300 days (d) 10 days.
28. Which of the following nuclear reactions will generate an isotope? [2007]  
(a)  $\beta$  - particle emission  
(b) Neutron particle emission  
(c) Positron emission  
(d)  $\alpha$  - particle emission.
29. For a reaction  $\frac{1}{2}A \rightarrow 2B$ , rate of disappearance of 'A' is related to the rate of appearance of 'B' by the expression [2008]  
(a)  $-\frac{d[A]}{dt} = \frac{1}{2} \frac{d[B]}{dt}$  (b)  $-\frac{d[A]}{dt} = \frac{1}{4} \frac{d[B]}{dt}$   
(c)  $-\frac{d[A]}{dt} = \frac{d[B]}{dt}$  (d)  $-\frac{d[A]}{dt} = 4 \frac{d[B]}{dt}$
30. The half life period of a first order chemical reaction is 6.93 minutes. The time required for the completion of 99% of the chemical reaction will be ( $\log 2 = 0.301$ ) [2009]  
(a) 23.03 minutes (b) 46.06 minutes  
(c) 460.6 minutes (d) 230.03 minutes
31. The time for half life period of a certain reaction  $A \longrightarrow$  Products is 1 hour. When the initial concentration of the reactant 'A', is  $2.0 mol L^{-1}$ , how much time does it take for its concentration to come from  $0.50$  to  $0.25 mol L^{-1}$  if it is a zero order reaction? [2010]  
(a) 4 h (b) 0.5 h  
(c) 0.25 h (d) 1 h
32. Consider the reaction :  
 $Cl_2(aq) + H_2S(aq) \rightarrow S(s) + 2H^+(aq) + 2Cl^-(aq)$   
The rate equation for this reaction is  
 $rate = k[Cl_2][H_2S]$   
Which of these mechanisms is/are consistent with this rate equation? [2010]  
A.  $Cl_2 + H_2S \rightarrow H^+ + Cl^- + Cl^+ + HS^-$  (slow)  
 $Cl^+ + HS^- \rightarrow H^+ + Cl^- + S$  (fast)  
B.  $H_2S \rightleftharpoons H^+ + HS^-$  (fast equilibrium)  
 $Cl_2 + HS^- \rightarrow 2Cl^- + H^+ + S$  (Slow)  
(a) B only (b) Both A and B  
(c) Neither A nor B (d) A only
33. The rate of a chemical reaction doubles for every  $10^\circ C$  rise of temperature. If the temperature is raised by  $50^\circ C$ , the rate of the reaction increases by about : [2011]  
(a) 10 times (b) 24 times  
(c) 32 times (d) 64 times
34. For a first order reaction  $(A) \rightarrow$  products the concentration of A changes from  $0.1 M$  to  $0.025 M$  in 40 minutes. The rate of reaction when the concentration of A is  $0.01 M$  is : [2012]  
(a)  $1.73 \times 10^{-5} M/min$  (b)  $3.47 \times 10^{-4} M/min$   
(c)  $3.47 \times 10^{-5} M/min$  (d)  $1.73 \times 10^{-4} M/min$
35. The rate of a reaction doubles when its temperature changes from  $300 K$  to  $310 K$ . Activation energy of such a reaction will be : ( $R = 8.314 JK^{-1} mol^{-1}$  and  $\log 2 = 0.301$ ) [JEE M 2013]  
(a)  $53.6 kJ mol^{-1}$  (b)  $48.6 kJ mol^{-1}$   
(c)  $58.5 kJ mol^{-1}$  (d)  $60.5 kJ mol^{-1}$
36. For the non - stoichiometre reaction  $2A + B \rightarrow C + D$ , the following kinetic data were obtained in three separate experiments, all at  $298 K$ . [JEE M 2014]

Initial Concentration (A)	Initial Concentration (B)	Initial rate of formation of C ( $mol L^{-1} s^{-1}$ )
0.1 M	0.1 M	$1.2 \times 10^{-3}$
0.1 M	0.2 M	$1.2 \times 10^{-3}$
0.2 M	0.1 M	$2.4 \times 10^{-3}$

The rate law for the formation of C is:

(a)  $\frac{dc}{dt} = k[A][B]$                       (b)  $\frac{dc}{dt} = k[A]^2[B]$

(c)  $\frac{dc}{dt} = k[A][B]^2$                       (d)  $\frac{dc}{dt} = k[A]$

37. Higher order (>3) reactions are rare due to : [JEE M 2015]

- (a) shifting of equilibrium towards reactants due to elastic collisions
- (b) loss of active species on collision
- (c) low probability of simultaneous collision of all the reacting species

(d) increase in entropy and activation energy as more molecules are involved

38. Decomposition of  $\text{H}_2\text{O}_2$  follows a first order reaction. In fifty minutes the concentration of  $\text{H}_2\text{O}_2$  decreases from 0.5 to 0.125 M in one such decomposition. When the concentration of  $\text{H}_2\text{O}_2$  reaches 0.05 M, the rate of formation of  $\text{O}_2$  will be:

[JEE M 2016]

- (a)  $2.66 \text{ L min}^{-1}$  at STP
- (b)  $1.34 \times 10^{-2} \text{ mol min}^{-1}$
- (c)  $6.96 \times 10^{-2} \text{ mol min}^{-1}$
- (d)  $6.93 \times 10^{-4} \text{ mol min}^{-1}$

## CHAPTER

## 15

# General Principles and Processes of Isolation of Elements

## Section-A JEE Advanced/ IIT-JEE

### A Fill in the Blanks

- Cassiterite is ore of ..... (1980)
- In the thermite process ..... is used as reducing agent. (1980)
- In the basic Bessemer process for the manufacture of steel the lining of the converter is made of ..... The slag formed consists of ..... (1980)
- In extractive metallurgy of zinc partial fusion of ZnO with coke is called ..... and reduction of the ore to the molten metal is called ..... (smelting, calcining, roasting, sintering) (1988 - 1 Mark)
- Which ore contains both iron and copper? (2005S)
  - Cuprite
  - Chalcocite
  - Chalcopyrite
  - Malachite
- Extraction of zinc from zinc blende is achieved by
  - electrolytic reduction (2007)
  - roasting followed by reduction with carbon
  - roasting followed by reduction with another metal
  - roasting followed by self-reduction

### C MCQs with One Correct Answer

- Copper can be extracted from (1978)
  - Kupfernickel
  - Dolomite
  - Malachite
  - Galena
- In the alumino-thermite process, aluminium acts as (1983 - 1 Mark)
  - an oxidizing agent
  - a flux
  - a reducing agent
  - a solder
- The chemical composition of 'slag' formed during the smelting process in the extraction of copper is (2001S)
  - $\text{Cu}_2\text{O} + \text{FeS}$
  - $\text{FeSiO}_3$
  - $\text{CuFeS}_2$
  - $\text{Cu}_2\text{S} + \text{FeO}$
- Which of the following process is used in the extractive metallurgy of magnesium? (2002S)
  - fused salt electrolysis
  - self reduction
  - aqueous solution electrolysis
  - thermite reduction
- Oxidation states of the metal in the minerals haematite and magnetite, respectively, are (2011)
  - II, III in haematite and III in magnetite
  - II, III in haematite and II in magnetite
  - II in haematite and II, III in magnetite
  - III in haematite and II, III in magnetite
- In the cyanide extraction process of silver from argentite ore, the oxidising and reducing agents used are (2012)
  - $\text{O}_2$  and CO respectively
  - $\text{O}_2$  and Zn dust respectively
  - $\text{HNO}_3$  and Zn dust respectively
  - $\text{HNO}_3$  and CO respectively
- Sulfide ores are common for the metals (JEE Adv. 2013)
  - Ag, Cu and Pb
  - Ag, Mg and Pb
  - Ag, Cu and Sn
  - Al, Cu and Pb

### D MCQs with One or More Than One Correct

- Of the following, the metals that cannot be obtained by electrolysis of the aqueous solution of their salts are : (1990 - 1 Mark)
  - Ag
  - Mg
  - Cu
  - Al
  - Cr

2. Extraction of metal from the ore **cassiterite** involves
- carbon reduction of an oxide ore (2011)
  - self-reduction of a sulphide ore
  - removal of copper impurity
  - removal of iron impurity
3. The carbon-based reduction method is **NOT** used for the extraction of (JEE Adv. 2013)
- Tin from  $\text{SnO}_2$
  - Iron from  $\text{Fe}_2\text{O}_3$
  - Aluminium from  $\text{Al}_2\text{O}_3$
  - Magnesium from  $\text{MgCO}_3 \cdot \text{CaCO}_3$
4. Upon heating with  $\text{Cu}_2\text{S}$ , the reagent(s) that give copper metal is/are (JEE Adv. 2014)
- $\text{CuFeS}_2$
  - $\text{CuO}$
  - $\text{Cu}_2\text{O}$
  - $\text{CuSO}_4$
5. Copper is purified by electrolytic refining of blister copper. The correct statement(s) about this process is(are) (JEE Adv. 2015)
- Impure Cu strip is used as cathode
  - Acidified aqueous  $\text{CuSO}_4$  is used as electrolyte
  - Pure Cu deposits at cathode
  - Impurities settle as anode-mud
6. Extraction of copper from copper pyrite ( $\text{CuFeS}_2$ ) involves (JEE Adv. 2016)
- crushing followed by concentration of the ore by froth-flotation
  - removal of iron as slag
  - self-reduction step to produce 'blister copper' following evolution of  $\text{SO}_2$
  - refining of 'blister copper' by carbon reduction

## E Subjective Problems

1. (a) Write the chemical equations involved in the extraction of lead from galena by self reduction process.
- (b) Match the following extraction processes with the appropriate metals listed below :
- |              |                               |
|--------------|-------------------------------|
| (i) Silver   | (A) Fused salt electrolysis   |
| (ii) Calcium | (B) Carbon reduction          |
| (iii) Zinc   | (C) Carbon monoxide reduction |
| (iv) Iron    | (D) Amalgamation              |
| (v) Copper   | (E) Self reduction (1979)     |
2. Write the matching pairs: (1980)
- |                 |                    |
|-----------------|--------------------|
| Bleaching agent | Aluminium          |
| Smelling salt   | Carbon             |
| Cryolite        | Tin                |
| Bell metal      | Ammonium carbonate |
| Fluorspar       | Ammonium phosphate |
| Fertilizer      | Calcium            |
| Anthracite      | Chlorine           |

### Examples :

- Bleaching agent  
Chlorine  
Smelling salt  
Ammonium carbonate
3. Give reasons for the following :
- Metals can be recovered from their ores by chemical methods. (1984 - 1 Mark)
  - High purity metals can be obtained by zone refining method. (1984 - 1 Mark)
  - Why is chalcocite roasted and not calcinated during recovery of copper? (1987 - 1 Mark)
4. Give the equations for the recovery of lead from Galena by air reduction. (1987 - 1 Mark)

## F Match the Following

Each question contains statements given in two columns, which have to be matched. The statements in Column-I are labelled A, B, C and D, while the statements in Column-II are labelled p, q, r, s and t. Any given statement in Column-I can have correct matching with ONE OR MORE statement(s) in Column-II. The appropriate bubbles corresponding to the answers to these questions have to be darkened as illustrated in the following example :

If the correct matches are A-p, s and t; B-q and r; C-p and q; and D-s then the correct darkening of bubbles will look like the given.

	p	q	r	s	t
A	<input checked="" type="checkbox"/>	<input type="checkbox"/>	<input type="checkbox"/>	<input checked="" type="checkbox"/>	<input checked="" type="checkbox"/>
B	<input type="checkbox"/>	<input checked="" type="checkbox"/>	<input checked="" type="checkbox"/>	<input type="checkbox"/>	<input type="checkbox"/>
C	<input checked="" type="checkbox"/>	<input checked="" type="checkbox"/>	<input type="checkbox"/>	<input type="checkbox"/>	<input type="checkbox"/>
D	<input type="checkbox"/>	<input type="checkbox"/>	<input type="checkbox"/>	<input checked="" type="checkbox"/>	<input type="checkbox"/>

General Principles and Processes of Isolation of Elements

1. Match the extraction processes listed in **Column I** with metals listed in **Column II** : (2006 - 6M)

**Column I**

- (A) Self reduction  
(B) Carbon reduction  
(C) Complex formation and displacement by metal  
(D) Decomposition of iodide

**Column II**

- (p) Lead  
(q) Silver  
(r) Copper  
(s) Boron

2. Match the conversions in **Column I** with the type(s) of reaction(s) given in **Column II**. (2008 - 6M)

**Column I**

- (A)  $\text{PbS} \rightarrow \text{PbO}$   
(B)  $\text{CaCO}_3 \rightarrow \text{CaO}$   
(C)  $\text{ZnS} \rightarrow \text{Zn}$   
(D)  $\text{Cu}_2\text{S} \rightarrow \text{Cu}$

**Column II**

- (p) roasting  
(q) calcination  
(r) carbon reduction  
(s) self reduction

3. Match the anionic species given in Column-I that are present in the ore(s) given in Column-II. (JEE Adv. 2015)

**Column-I**

- (A) Carbonate  
(B) Sulphide  
(C) Hydroxide  
(D) Oxide

**Column-II**

- (p) Siderite  
(q) Malachite  
(r) Bauxite  
(s) Calamine  
(t) Argentite

**Section-B**

**JEE Main / AIEEE**

1. Aluminium is extracted by the electrolysis of [2002]  
(a) bauxite  
(b) alumina  
(c) alumina mixed with molten cryolite  
(d) molten cryolite.
2. The metal extracted by leaching with a cyanide is [2002]  
(a) Mg  
(b) Ag  
(c) Cu  
(d) Na.
3. Which one of the following ores is best concentrated by froth-flotation method ? [2004]  
(a) Galena  
(b) Cassiterite  
(c) Magnetite  
(d) Malachite
4. During the process of electrolytic refining of copper, some metals present as impurity settle as 'anode mud'. These are [2005]  
(a) Fe and Ni  
(b) Ag and Au  
(c) Pb and Zn  
(d) Sn and Ag
5. Which of the following factors is of **no significance** for roasting sulphide ores to the oxides and not subjecting the sulphide ores to carbon reduction directly? [2008]  
(a) Metal sulphides are thermodynamically more stable than  $\text{CS}_2$   
(b)  $\text{CO}_2$  is thermodynamically more stable than  $\text{CS}_2$   
(c) Metal sulphides are less stable than the corresponding oxides  
(d)  $\text{CO}_2$  is more volatile than  $\text{CS}_2$
6. 29.5 mg of an organic compound containing nitrogen was digested according to Kjeldahl's method and the evolved ammonia was absorbed in 20 mL of 0.1 M HCl solution. The excess of the acid required 15 mL of 0.1 M NaOH solution for complete neutralization. The percentage of nitrogen in the compound is [2010]  
(a) 59.0  
(b) 47.4  
(c) 23.7  
(d) 29.5
7. Which method of purification is represented by the following equation ? [2012]  
$$\text{Ti(s)} + 2\text{I}_2(\text{g}) \xrightarrow{523\text{K}} \text{TiI}_4(\text{g}) \xrightarrow{1700\text{K}} \text{Ti(s)} + 2\text{I}_2(\text{g})$$
  
(a) Zone refining  
(b) Cupellation  
(c) Polling  
(d) Van Arkel

8. The metal that cannot be obtained by electrolysis of an aqueous solution of its salts is: [JEE M 2014]
- (a) Ag
  - (b) Ca
  - (c) Cu
  - (d) Cr
9. In the context of the Hall - Heroult process for the extraction of Al, which of the following statements is **false** ? [JEE M 2015]
- (a)  $\text{Al}^{3+}$  is reduced at the cathode to form Al
  - (b)  $\text{Na}_3\text{AlF}_6$  serves as the electrolyte
  - (c) CO and  $\text{CO}_2$  are produced in this process
  - (d)  $\text{Al}_2\text{O}_3$  is mixed with  $\text{CaF}_2$  which lowers the melting point of the mixture and brings conductivity
10. Which one of the following ores is best concentrated by froth floatation method? [JEE M 2016]
- (a) Galena
  - (b) Malachite
  - (c) Magnetite
  - (d) Siderite



## CHAPTER

## 16

## The p-Block Elements

## Section-A JEE Advanced/ IIT-JEE

## A Fill in the Blanks

- The lowest possible oxidation state of nitrogen is (1980)
- Iodine reacts with hot NaOH solution. The products are NaI and ..... (1980)
- ..... is a weak acid. (HF, HCl, HI) (1981 - 1 Mark)
- The increase in the solubility of iodine in an aqueous solution of potassium iodide is due to the formation of ..... (1982 - 1 Mark)
- Hydrogen gas is liberated by the action of aluminium with concentrated solution of ..... (1987 - 1 Mark)
- ..... phosphorus is reactive because of its highly strained tetrahedral structure. (1987 - 1 Mark)
- ..... acid gives hypo ..... ion. (1988 - 1 Mark) (hydrobromic, hypobromous, perbromic, bromide, bromite, perbromate)
- Sulphur acts as ..... agent in vulcanization of rubber. (1989 - 1 Mark)
- The basicity of phosphorous acid ( $\text{H}_3\text{PO}_3$ ) is ..... (1990 - 1 Mark)
- The hydrolysis of alkyl substituted chlorosilanes gives ..... (1991 - 1 Mark)
- In  $\text{P}_4\text{O}_{10}$ , the number of oxygen atoms bonded to each phosphorus atom is ..... (1992 - 1 Mark)
- The lead chamber process involves oxidation of  $\text{SO}_2$  by atomic oxygen under the influence of ..... as catalyst. (1992 - 1 Mark)
- The hydrolysis of trialkylchlorosilane  $\text{R}_3\text{SiCl}$ , yields ..... (1994 - 1 Mark)
- One recently discovered allotrope of carbon (e.g.,  $\text{C}_{60}$ ) is commonly known as ..... (1994 - 1 Mark)
- Solubility of iodine in water is greatly increased by the addition of iodide ions because of the formation of ..... (1994 - 1 Mark)
- A liquid which is permanently supercooled is frequently called a ..... (1997 - 1 Mark)
- Compounds that formally contain  $\text{Pb}^{4+}$  are easily reduced to  $\text{Pb}^{2+}$ . The stability of the lower oxidation state is due to ..... (1997 - 1 Mark)

## B True / False

- Red phosphorus is less volatile than white phosphorus because the former has a tetrahedral structure. (1982 - 1 Mark)
- When  $\text{PbO}_2$  reacts with a dilute acid, it gives hydrogen peroxide. (1982 - 1 Mark)
- Carbon tetrachloride burns in air when lighted to give phosgene. (1983 - 1 Mark)
- Dil. HCl oxidizes metallic Fe to  $\text{Fe}^{2+}$ . (1983 - 1 Mark)
- In aqueous solution chlorine is a stronger oxidizing agent than fluorine. (1984 - 1 Mark)
- The H-N-H bond angle in  $\text{NH}_3$  is greater than the H-As-H bond angle in  $\text{AsH}_3$ . (1984 - 1 Mark)
- Carbon tetrachloride is inflammable. (1985 - 1/2 Mark)
- Graphite is better lubricant on the moon than on the earth. (1987 - 1 Mark)
- All the Al-Cl bonds in  $\text{Al}_2\text{Cl}_6$  are equivalent. (1989 - 1 Mark)
- Nitric oxide, though an odd electron molecule, is diamagnetic in liquid state. (1991 - 1 Mark)
- Diamond is harder than graphite. (1993 - 1 Mark)
- The tendency for catenation is much higher for C than for Si. (1993 - 1 Mark)
- HBr is a stronger acid than HI because of hydrogen bonding. (1993 - 1 Mark)

## C MCQs with One Correct Answer

- The reddish brown coloured gas formed when nitric oxide is oxidised by air is (1979)
 

(a) $\text{N}_2\text{O}_5$	(b) $\text{N}_2\text{O}_4$
(c) $\text{NO}_2$	(d) $\text{N}_2\text{O}_3$
- The temporary hardness of water due to calcium carbonate can be removed by adding – (1979)
 

(a) $\text{CaCO}_3$	(b) $\text{Ca(OH)}_2$
(c) $\text{CaCl}_2$	(d) HCl
- Which of the following is most stable to heat (1980)
 

(a) HCl	(b) HOCl
(c) HBr	(d) HI

4. White P reacts with caustic soda. The products are  $\text{PH}_3$  and  $\text{NaH}_2\text{PO}_2$ . This reaction is an example of (1980)  
 (a) Oxidation (b) Reduction  
 (c) oxidation and reduction (d) Neutralisation
5. A solution of KBr is treated with each of the following. Which one would liberate bromine (1980)  
 (a)  $\text{Cl}_2$  (b) HI  
 (c)  $\text{I}_2$  (d)  $\text{SO}_2$
6. Which of the following is coloured (1980)  
 (a) NO (b)  $\text{N}_2\text{O}$   
 (c)  $\text{SO}_3$  (d) None
7. Lead pencil contains (1980)  
 (a) Pb (b) FeS  
 (c) Graphite (d) PbS
8. Ammonia can be dried by (1980)  
 (a) Conc.  $\text{H}_2\text{SO}_4$  (b)  $\text{P}_2\text{O}_5$   
 (c) Anhydrous  $\text{CuSO}_4$  (d) none
9. HBr and HI reduce sulphuric acid, HCl can reduce  $\text{KMnO}_4$  and HF can reduce (1981 - 1 Mark)  
 (a)  $\text{H}_2\text{SO}_4$  (b)  $\text{KMnO}_4$   
 (c)  $\text{K}_2\text{Cr}_2\text{O}_7$  (d) none of the above
10. Which of the following statements about anhydrous aluminium chloride is correct? (1981 - 1 Mark)  
 (a) it exists as  $\text{AlCl}_3$  molecules  
 (b) it is not easily hydrolysed  
 (c) it sublimes at  $100^\circ\text{C}$  under vacuum  
 (d) it is a strong Lewis base
11. Moderate electrical conductivity is shown by (1982 - 1 Mark)  
 (a) silica (b) graphite  
 (c) diamond (d) carborundum
12. Chlorine acts as a bleaching agent only in presence of (1983 - 1 Mark)  
 (a) dry air (b) moisture  
 (c) sunlight (d) pure oxygen
13. Nitrogen dioxide cannot be obtained by heating : (1985 - 1 Mark)  
 (a)  $\text{KNO}_3$  (b)  $\text{Pb}(\text{NO}_3)_2$   
 (c)  $\text{Cu}(\text{NO}_3)_2$  (d)  $\text{AgNO}_3$
14. A gas that cannot be collected over water is : (1985 - 1 Mark)  
 (a)  $\text{N}_2$  (b)  $\text{O}_2$   
 (c)  $\text{SO}_2$  (d)  $\text{PH}_3$
15. The compound which gives off oxygen on moderate heating is : (1986 - 1 Mark)  
 (a) cupric oxide (b) mercuric oxide  
 (c) zinc oxide (d) aluminium oxide
16. The bonds present in  $\text{N}_2\text{O}_5$  are : (1986 - 1 Mark)  
 (a) only ionic (b) covalent and coordinate  
 (c) only covalent (d) covalent and ionic
17. Which of the following oxides of nitrogen is a coloured gas? (1987 - 1 Mark)  
 (a)  $\text{N}_2\text{O}$  (b) NO  
 (c)  $\text{N}_2\text{O}_5$  (d)  $\text{NO}_2$
18. Amongst the trihalides of nitrogen which one is least basic? (1987 - 1 Mark)  
 (a)  $\text{NF}_3$  (b)  $\text{NCl}_3$   
 (c)  $\text{NBr}_3$  (d)  $\text{NI}_3$
19. Bromine can be liberated from potassium bromide solution by the action of (1987 - 1 Mark)  
 (a) Iodine solution (b) Chlorine water  
 (c) Sodium chloride (d) Potassium iodide
20. There is no S-S bond in : (1991 - 1 Mark)  
 (a)  $\text{S}_2\text{O}_4^{2-}$  (b)  $\text{S}_2\text{O}_5^{2-}$   
 (c)  $\text{S}_2\text{O}_3^{2-}$  (d)  $\text{S}_2\text{O}_7^{2-}$
21. In  $\text{P}_4\text{O}_{10}$  each P atom is linked with ..... O atoms (1995S)  
 (a) 2 (b) 3  
 (c) 4 (d) 5
22.  $\text{H}_2\text{SO}_4$  cannot be used to prepare HBr from NaBr as it : (1995S)  
 (a) reacts slowly with NaBr (b) oxidises HBr  
 (c) reduces HBr (d) disproportionates HBr
23. Hydrolysis of one mole of peroxodisulphuric acid produces (1996 - 1 Mark)  
 (a) two moles of sulphuric acid  
 (b) two moles of peroxomonosulphuric acid  
 (c) one mole of sulphuric acid and one mole of peroxomonosulphuric acid  
 (d) one mole of sulphuric acid, one mole of peroxomonosulphuric acid and one mole of hydrogen peroxide.
24. Which of the following statements is correct for  $\text{CsBr}_3$ ? (1996 - 1 Mark)  
 (a) It is a covalent compound.  
 (b) It contains  $\text{Cs}^{3+}$  and  $\text{Br}^-$  ions.  
 (c) It contains  $\text{Cs}^+$  and  $\text{Br}_3^-$  ions  
 (d) It contains  $\text{Cs}^+$ , and  $\text{Br}^-$  and lattice  $\text{Br}_2$  molecule
25. KF combines with HF to form  $\text{KHF}_2$ . The compound contains the species. (1996 - 1 Mark)  
 (a)  $\text{K}^+$ ,  $\text{F}^-$  and  $\text{H}^+$  (b)  $\text{K}^+$ ,  $\text{F}^-$  and HF  
 (c)  $\text{K}^+$  and  $[\text{HF}_2]^-$  (d)  $[\text{KHF}]^+$  and  $\text{F}^-$
26. Sodium thiosulphate is prepared by (1996 - 1 Mark)  
 (a) reducing  $\text{Na}_2\text{SO}_4$  solution with  $\text{H}_2\text{S}$   
 (b) boiling  $\text{Na}_2\text{SO}_3$  solution with S in alkaline medium  
 (c) neutralising  $\text{H}_2\text{S}_2\text{O}_3$  solution with NaOH  
 (d) boiling  $\text{Na}_2\text{SO}_3$  solution with S in acidic medium
27. Which of the following halides is least stable and has doubtful existence? (1996 - 1 Mark)  
 (a)  $\text{Cl}_4$  (b)  $\text{GeI}_4$   
 (c)  $\text{SnI}_4$  (d)  $\text{PbI}_4$
28. Which one of the following oxides is neutral? (1996 - 1 Mark)  
 (a) CO (b)  $\text{SnO}_2$   
 (c) ZnO (d)  $\text{SiO}_2$
29. Which one of the following species is not a pseudohalide? (1997 - 1 Mark)  
 (a)  $\text{CNO}^-$  (b)  $\text{RCOO}^-$   
 (c)  $\text{OCN}^-$  (d)  $\text{NNN}^-$
30. One mole of calcium phosphide on reaction with excess water gives (1999 - 2 Marks)  
 (a) one mole of phosphine  
 (b) two moles of phosphoric acid  
 (c) two moles of phosphine  
 (d) one mole of phosphorus pentoxide

31. On heating ammonium dichromate, the gas evolved is (1999 - 2 Marks)
- (a) oxygen (b) ammonia  
(c) nitrous oxide (d) nitrogen
32. In the commercial electrochemical process for aluminium extraction the electrolyte used is (1999 - 2 Marks)
- (a)  $\text{Al(OH)}_3$  in NaOH solution  
(b) an aqueous solution of  $\text{Al}_2(\text{SO}_4)_3$   
(c) a molten mixture of  $\text{Al}_2\text{O}_3$  and  $\text{Na}_3\text{AlF}_6$   
(d) a molten mixture of  $\text{AlO(OH)}$  and  $\text{Al(OH)}_3$
33. In compounds of type  $\text{ECl}_3$ , where E = B, P, As or Bi, the angles Cl – E – Cl for different E are in the order (1999 - 2 Marks).
- (a)  $\text{B} > \text{P} = \text{As} = \text{Bi}$  (b)  $\text{B} > \text{P} > \text{As} > \text{Bi}$   
(c)  $\text{B} < \text{P} = \text{As} = \text{Bi}$  (d)  $\text{B} < \text{P} < \text{As} < \text{Bi}$
34. Electrolytic reduction of alumina to aluminium by Hall-Heroult process is carried out (2000S)
- (a) in the presence of NaCl  
(b) in the presence of fluorite  
(c) in the presence of cryolite which forms a melt with lower melting temperature  
(d) in the presence of cryolite which forms a melt with higher melting temperature
35. The number of P – O – P bonds in cyclic metaphosphoric acid is (2000S)
- (a) zero (b) two  
(c) three (d) four
36. Ammonia can be dried by (2000S)
- (a) conc.  $\text{H}_2\text{SO}_4$  (b)  $\text{P}_4\text{O}_{10}$   
(c) CaO (d) anhydrous  $\text{CaCl}_2$
37. The number of S – S bonds in sulphur trioxide trimer ( $\text{S}_3\text{O}_9$ ) is (2001S)
- (a) three (b) two  
(c) one (d) zero
38. Polyphosphates are used as water softening agents because they (2002S)
- (a) form soluble complexes with anionic species  
(b) precipitate anionic species  
(c) form soluble complexes with cationic species  
(d) precipitate cationic species
39. For  $\text{H}_3\text{PO}_3$  and  $\text{H}_3\text{PO}_4$  the correct choice is: (2003S)
- (a)  $\text{H}_3\text{PO}_3$  is dibasic and reducing  
(b)  $\text{H}_3\text{PO}_3$  is dibasic and non-reducing  
(c)  $\text{H}_3\text{PO}_4$  is tribasic and reducing  
(d)  $\text{H}_3\text{PO}_3$  is tribasic and non-reducing
40.  $\text{H}_3\text{BO}_3$  is: (2003S)
- (a) Monobasic and weak Lewis acid  
(b) Monobasic and weak Bronsted acid  
(c) Monobasic and strong Lewis acid  
(d) Tribasic and weak Bronsted acid
41.  $(\text{Me})_2\text{SiCl}_2$  on hydrolysis will produce (2003S)
- (a)  $(\text{Me})_2\text{Si(OH)}_2$  (b)  $(\text{Me})_2\text{Si}=\text{O}$   
(c)  $[-\text{O}-(\text{Me})_2\text{Si}-\text{O}]_n-$  (d)  $\text{Me}_2\text{SiCl(OH)}$
42. Total number of lone pair of electrons in  $\text{XeOF}_4$  is (2004S)
- (a) 0 (b) 1  
(c) 2 (d) 3
43. The acid having O – O bond is (2004S)
- (a)  $\text{H}_2\text{S}_2\text{O}_3$  (b)  $\text{H}_2\text{S}_2\text{O}_6$   
(c)  $\text{H}_2\text{S}_2\text{O}_8$  (d)  $\text{H}_2\text{S}_4\text{O}_6$
44. Pb and Sn are extracted from their chief ores by (2004S)
- (a) carbon reduction and self reduction respectively  
(b) self reduction and carbon reduction respectively  
(c) electrolysis and self reduction respectively  
(d) self reduction and electrolysis respectively
45. Name of the structure of silicates in which three oxygen atoms of  $[\text{SiO}_4]^{4-}$  are shared. (2005S)
- (a) Pyrosilicate  
(b) Sheet silicate  
(c) Linear chain silicate  
(d) Three dimensional silicate
46. Which is the most thermodynamically stable allotropic form of phosphorus? (2005S)
- (a) red (b) white  
(c) black (d) yellow
47. Which of the following is not oxidized by  $\text{O}_3$ ? (2005S)
- (a) KI (b)  $\text{FeSO}_4$   
(c)  $\text{KMnO}_4$  (d)  $\text{K}_2\text{MnO}_4$
48. Blue liquid which is obtained on reacting equimolar amounts of two gases at  $-30^\circ\text{C}$  is? (2005S)
- (a)  $\text{N}_2\text{O}$  (b)  $\text{N}_2\text{O}_3$   
(c)  $\text{N}_2\text{O}_4$  (d)  $\text{N}_2\text{O}_5$
49. When  $\text{PbO}_2$  reacts with conc.  $\text{HNO}_3$  the gas evolved is (2005S)
- (a)  $\text{NO}_2$  (b)  $\text{O}_2$   
(c)  $\text{N}_2$  (d)  $\text{N}_2\text{O}$
50. How can the following reaction be made to proceed in forward direction? (2006 - 3M, -1)
- $$\text{B(OH)}_3 + \text{NaOH} \rightleftharpoons \text{NaBO}_2 + \text{Na[B(OH)}_4] + \text{H}_2\text{O}$$
- (a) addition of borax  
(b) addition of *cis*-1,2-diol  
(c) addition of  $\text{Na}_2\text{HPO}_4$   
(d) addition of *trans*-1,2-diol
51. The percentage of  $\pi$ -character in the orbitals forming P – P bonds in  $\text{P}_4$  is (2007)
- (a) 25 (b) 33  
(c) 50 (d) 75
52. Aqueous solution of  $\text{Na}_2\text{S}_2\text{O}_3$  on reaction with  $\text{Cl}_2$  gives – (2008)
- (a)  $\text{Na}_2\text{S}_4\text{O}_6$  (b)  $\text{NaHSO}_4$   
(c) NaCl (d) NaOH
53. The reaction of  $\text{P}_4$  with X leads selectively to  $\text{P}_4\text{O}_6$ . The X is (2009)
- (a) Dry  $\text{O}_2$   
(b) A mixture of  $\text{O}_2$  and  $\text{N}_2$   
(c) Moist  $\text{O}_2$   
(d)  $\text{O}_2$  in the presence of aqueous NaOH

54. Extra pure  $N_2$  can be obtained by heating (2011)
- $NH_3$  with  $CuO$
  - $NH_4NO_3$
  - $(NH_4)_2Cr_2O_7$
  - $Ba(N_3)_2$
55. Which ordering of compounds is according to the decreasing order of the oxidation state of nitrogen? (2012)
- $HNO_3, NO, NH_4Cl, N_2$
  - $HNO_3, NO, N_2, NH_4Cl$
  - $HNO_3, NH_4Cl, NO, N_2$
  - $NO, HNO_3, NH_4Cl, N_2$
56. The reaction of white phosphorus with aqueous  $NaOH$  gives phosphine along with another phosphorus containing compound. The reaction type; the oxidation states of phosphorus in phosphine and the other product are respectively (2012)
- redox reaction;  $-3$  and  $-5$
  - redox reaction;  $+3$  and  $+5$
  - disproportionation reaction;  $-3$  and  $+5$
  - disproportionation reaction;  $-3$  and  $+3$
57. The shape of  $XeO_2F_2$  molecule is (2012)
- trigonal bipyramidal
  - square planar
  - tetrahedral
  - see-saw
58. Concentrated nitric acid, upon long standing, turns yellow brown due to the formation of (JEE Advanced 2013)
- $NO$
  - $NO_2$
  - $N_2O$
  - $N_2O_4$
59. The product formed in the reaction of  $SOCl_2$  with white phosphorous is (JEE Adv. 2014)
- $PCl_3$
  - $SO_2Cl_2$
  - $SCl_2$
  - $POCl_3$
60. Under ambient conditions, the total number of gases released as products in the final step of the reaction scheme shown below is (JEE Adv. 2014)

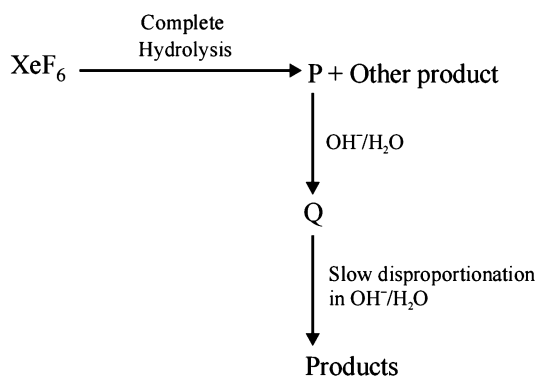

- 0
  - 1
  - 2
  - 3
61. The increasing order of atomic radii of the following Group 13 elements is
- $Al < Ga < In < Tl$
  - $Ga < Al < In < Tl$
  - $Al < In < Ga < Tl$
  - $Al < Ga < Tl < In$
- (JEE Adv. 2016)
62. In the following reaction sequence in aqueous solution, the species X, Y and Z, respectively, are (JEE Adv. 2016)

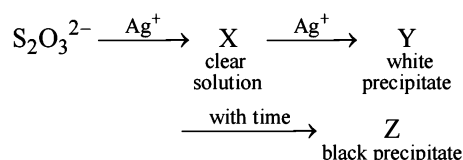

- $[Ag(S_2O_3)_2]^{3-}, Ag_2S_2O_3, Ag_2S$
- $[Ag(S_2O_3)_3]^{5-}, Ag_2SO_3, Ag_2S$
- $[Ag(SO_3)_2]^{3-}, Ag_2S_2O_3, Ag$
- $[Ag(SO_3)_3]^{3-}, Ag_2SO_4, Ag$

### D MCQs with One or More Than One Correct

- In the electrolysis of alumina, cryolite is added to : (1986 - 1 Mark)
  - lower the melting point of alumina
  - increase the electrical conductivity
  - minimise the anode effect
  - remove impurities from alumina
- Nitrogen(I) oxide is produced by : (1989 - 1 Mark)
  - thermal decomposition of ammonium nitrate
  - disproportionation of  $N_2O_4$
  - thermal decomposition of ammonium nitrite
  - interaction of hydroxylamine and nitrous acid.
- The compounds used as refrigerant are (1990 - 1 Mark)
  - $NH_3$
  - $CCl_4$
  - $CF_4$
  - $CF_2Cl_2$
  - $CH_2F_2$
- The major role of fluorspar ( $CaF_2$ ), which is added in small quantities in the electrolytic reduction of alumina dissolved in fused cryolite ( $Na_3AlF_6$ ), is (1993 - 1 Mark)
  - as a catalyst
  - to make the fused mixture very conducting
  - to lower the temperature of the melt
  - to decrease the rate of oxidation of carbon at the anode.
- The material used in the solar cells contains (1993 - 1 Mark)
  - Cs
  - Si
  - Sn
  - Ti
- Sodium nitrate decomposes above  $800^\circ C$  to give (1998 - 2 Marks)
  - $N_2$
  - $O_2$
  - $NO_2$
  - $Na_2O$

7. White phosphorus ( $P_4$ ) has (1998 - 2 Marks)
- six P-P single bonds
  - four P-P single bonds
  - four lone pairs of electrons
  - PPP angle of  $60^\circ$
8. Ammonia, on reaction with hypochlorite anion, can form (1999 - 3 Marks)
- NO
  - $NH_4Cl$
  - $N_2H_4$
  - $HNO_2$
9. A solution of colourless salt H on boiling with excess NaOH produces a non-flammable gas. The gas evolution ceases after sometime. Upon addition of Zn dust to the same solution, the gas evolution restarts. The colourless salt (s) H is (are) (2008)
- $NH_4NO_3$
  - $NH_4NO_2$
  - $NH_4Cl$
  - $(NH_4)_2SO_4$
10. The nitrogen oxide(s) that contain(s) N-N bond(s) is(are) (2009)
- $N_2O$
  - $N_2O_3$
  - $N_2O_4$
  - $N_2O_5$
11. Which of the following halides react(s) with  $AgNO_3(aq)$  to give a precipitate that dissolves in  $Na_2S_2O_3(aq)$ ? (2012)
- HCl
  - HF
  - HBr
  - HI
12. With respect to graphite and diamond, which of the statement(s) given below is (are) correct? (2012)
- Graphite is harder than diamond.
  - Graphite has higher electrical conductivity than diamond.
  - Graphite has higher thermal conductivity than diamond.
  - Graphite has higher C-C bond order than diamond.
13. The correct statement(s) about  $O_3$  is(are) (JEE Adv. 2013-II)
- O—O bond lengths are equal
  - Thermal decomposition of  $O_3$  is endothermic
  - $O_3$  is diamagnetic in nature
  - $O_3$  has a bent structure
14. For the reaction (JEE Adv. 2014)
- $$I^- + ClO_3^- + H_2SO_4 \rightarrow Cl^- + HSO_4^- + I_2$$
- The correct statement(s) in the balanced equation is/are
- Stoichiometric coefficient of  $HSO_4^-$  is 6
  - Iodide is oxidized
  - Sulphur is reduced
  - $H_2O$  is one of the products
15. The correct statement(s) for orthoboric acid is/are (JEE Adv. 2014)
- It behaves as a weak acid in water due to self ionization.
  - Acidity of its aqueous solution increases upon addition of ethylene glycol
  - It has a three dimensional structure due to hydrogen bonding
  - It is a weak electrolyte in water
16. The correct statement(s) regarding, (i)  $HClO$ , (ii)  $HClO_2$ , (iii)  $HClO_3$  and (iv)  $HClO_4$ , is(are) (JEE Adv. 2015)
- The number of Cl=O bonds in (ii) and (iii) together is two
  - The number of lone pairs of electrons on Cl in (ii) and (iii) together is three
  - The hybridization of Cl in (iv) is  $sp^3$
  - Amongst (i) to (iv), the strongest acid is (i)
17. Under hydrolytic conditions, the compounds used for preparation of linear polymer and for chain termination, respectively, are (JEE Adv. 2015)
- $CH_3SiCl_3$  and  $Si(CH_3)_4$
  - $(CH_3)_2SiCl_2$  and  $(CH_3)_3SiCl$
  - $(CH_3)_2SiCl_2$  and  $CH_3SiCl_3$
  - $SiCl_4$  and  $(CH_3)_3SiCl$
18. The crystalline form of borax has (JEE Adv. 2016)
- tetranuclear  $[B_4O_5(OH)_4]^{2-}$  unit
  - all boron atoms in the same plane
  - equal number of  $sp^2$  and  $sp^3$  hybridized boron atoms
  - one terminal hydroxide per boron atom
19. The nitrogen containing compound produced in the reaction of  $HNO_3$  with  $P_4O_{10}$  (JEE Adv. 2016)
- can also be prepared by reaction of  $P_4$  and  $HNO_3$
  - is diamagnetic
  - contains one N-N bond
  - reacts with Na metal producing a brown gas

## E Subjective Problems

- Account for the following. Limit your answer to two sentences
  - Hydrogen bromide cannot be prepared by action of concentrated sulphuric acid or sodium bromide.
  - When a blue litmus paper is dipped into a solution of hypochlorous acid, it first turns red and then later gets decolourised. (1979)
- Write balanced equation involved in the preparation of
  - Anhydrous aluminium chloride from alumina.
  - Bleaching powder from slaked lime.
  - Tin metal from cassiterite
  - Chlorine from sodium chloride.
  - Nitric oxide from nitric acid. (1979)
- State with balanced equations, what happens when :
  - Tin is treated with moderately concentrated nitric acid.
  - Aluminium is reacted with hot concentrated caustic soda solution (1979)
- Give structural formula for the following :
  - Phosphorous acid,  $H_3PO_3$  (1981 - 1 Mark)
  - Pyrophosphoric acid,  $H_4P_2O_7$  (1981 - 1 Mark)

5. Complete the following equations (no balancing is needed)
- (i)  $\text{HCO}_3^- + \text{Al}^{3+} \longrightarrow \text{Al}(\text{OH})_3 + \dots$  (1981 - 1 Mark)
- (ii)  $\text{AlBr}_3 + \text{K}_2\text{Cr}_2\text{O}_7 + \text{H}_3\text{PO}_4 \longrightarrow \text{K}_3\text{PO}_4 + \text{AlPO}_4 + \text{H}_2\text{O} + \dots + \dots$  (1981 - 1 Mark)
6. Give reasons for the following :
- (i) Carbon acts as an abrasive and also as a lubricant. (1981 - 1 Mark)
- (ii) Sulphur melts to a clear mobile liquid at 119°C, but on further heating above 160°C, it becomes viscous. (1981 - 1 Mark)
- (iii) In the preparation of hydrogen iodide from alkali iodides, phosphoric acid is preferred to sulphuric acid (1982 - 1 Mark)
- (iv) Orthophosphoric acid,  $\text{H}_3\text{PO}_4$ , is tribasic, but phosphorous acid,  $\text{H}_3\text{PO}_3$ , is dibasic. (1982 - 1 Mark)
- (v) A bottle of liquor ammonia should be cooled before opening the stopper. (1983 - 1 Mark)
- (vi) Solid carbon dioxide is known as dry ice. (1983 - 1 Mark)
- (vii) Anhydrous HCl is a bad conductor of electricity but aqueous HCl is a good conductor; (1985 - 1 Mark)
- (viii) Graphite is used as a solid lubricant; (1985 - 1 Mark)
- (ix) Fluorine cannot be prepared from fluorides by chemical oxidation. (1985 - 1 Mark)
- (x) The mixture of hydrazine and hydrogen peroxide with a copper(II) catalyst is used as a rocket propellant. (1987 - 1 Mark)
- (xi) Orthophosphorus acid is not tribasic acid. (1987 - 1 Mark)
- (xii) The molecule of magnesium chloride is linear whereas that of stannous chloride is angular. (1987 - 1 Mark)
- (xiii) Valency of oxygen is generally two whereas sulphur shows valency of two, four and six. (1988 - 1 Mark)
- (xiv)  $\text{H}_3\text{PO}_3$  is a dibasic acid. (1989 - 1 Mark)
- (xv) Phosphine has lower boiling point than ammonia. (1989 - 1 Mark)
- (xvi) Ammonium chloride is acidic in liquid ammonia solvent. (1991 - 1 Mark)
- (xvii) The hydroxides of aluminium and iron are insoluble in water. However, NaOH is used to separate one from the other. (1991 - 1 Mark)
- (xviii) Bond dissociation energy of  $\text{F}_2$  is less than that of  $\text{Cl}_2$ . (1992 - 1 Mark)
- (xix) Sulphur dioxide is a more powerful reducing agent in an alkaline medium than in acidic medium. (1992 - 1 Mark)
- (xx) The experimentally determined N–F bond length in  $\text{NF}_3$  is greater than the sum of the single covalent bond radii of N and F. (1995 - 2 Marks)
- (xxi)  $\text{Mg}_3\text{N}_2$  when reacted with water gives off  $\text{NH}_3$  but HCl is not obtained from  $\text{MgCl}_2$  on reaction with water at room temperature. (1995 - 2 Marks)
- (xxii)  $(\text{SiH}_3)_3\text{N}$  is a weaker base than  $(\text{CH}_3)_3\text{N}$ . (1995 - 2 Marks)
7. State with balanced equations what happens when :
- (i) White phosphorous ( $\text{P}_4$ ) is boiled with a strong solution of sodium hydroxide in an inert atmosphere. (1982/87 - 1 Mark)
- (ii) Sodium iodate is treated with sodium bisulphite solution. (1982 - 1 Mark)
- (iii) Dilute nitric acid is slowly reacted with metallic tin. (1987 - 1 Mark)
- (iv) Potassium permanganate is reacted with warm solution of oxalic acid in the presence of sulphuric acid. (1987 - 1 Mark)
- (v) Iodate ion reacts with bisulphite ion to liberate iodine. (1988 - 1 Mark)
- (vi) Phosphorus reacts with nitric acid to give equimolar ratio of nitric oxide and nitrogen dioxide. (1988 - 1 Mark)
- (vii) Hypophosphorous acid is heated. (1989 - 1 Mark)
- (viii) Sodium bromate reacts with fluorine in presence of alkali. (1989 - 1 Mark)
- (ix) Sodium chlorate reacts with sulphur dioxide in dilute sulphuric acid medium. (1989 - 1 Mark)
- (x) Write balanced equations for the preparation of crystalline silicon from  $\text{SiCl}_4$ . (1990 - 1 Mark)
- (xi) Write balanced equations for the preparation of phosphine from CaO and white phosphorus. (1990 - 2 Marks)
- (xii) Write balanced equations for the preparation of ammonium sulphate from gypsum, ammonia and carbon dioxide. (1990 - 1 Mark)
- (xiii) Aqueous solution of sodium nitrate is heated with zinc dust and caustic soda solution. (1990 - 1 Mark)
- (xiv) Sodium iodate is added to a solution of sodium bisulphite. (1990 - 1 Marks)
- (xv) Sodium nitrite is produced by absorbing the oxides of nitrogen in aqueous solution of washing soda. (1991 - 1 Mark)
- (xvi) Nitrogen is obtained in the reaction of aqueous ammonia with potassium permanganate. (1991 - 1 Mark)

(xvii) Elemental phosphorus reacts with conc.  $\text{HNO}_3$  to give phosphoric acid. (1991 - 1 Mark)

(xviii) Sulphur is precipitated in the reaction of hydrogen sulphide with sodium bisulphite solution. (1991 - 1 Mark)

(xix) Phosphorus is treated with concentrated nitric acid. (1997 - 1 Mark)

OR

Manufacture of phosphoric acid from phosphorus. (1997 - 1 Mark)

(xx) Reaction of aluminium with aqueous sodium hydroxide. (1997 - 1 Mark)

(xxi) Aluminium sulphide gives a foul odour when it becomes damp. Write a balanced chemical equation for the reaction. (1997 - 2 Marks)

(xxii)  $\text{P}_4\text{O}_{10} + \text{PCl}_5 \rightarrow$  (1998 - 1 Mark)

(xxiii)  $\text{SnCl}_4 + \text{C}_2\text{H}_5\text{Cl} + \text{Na} \rightarrow$  (1998 - 1 Mark)

8. Show with equations how the following compound is prepared (equations need not be balanced) sodium thiosulphate from sodium sulphite. (1982 - 1 Mark)

9. Give balanced equations for the extraction of aluminium from bauxite by electrolysis. (1982 - 2 Marks)

10. State the conditions under which the following preparation is carried out. Give the necessary equations which need not be balanced: Alumina from aluminium. (1983 - 1 Mark)

11. Write down the resonance structures of nitrous oxide. (1985 - 2 Marks)

OR

Write the two resonance structures of  $\text{N}_2\text{O}$  that satisfy the octet rule. (1990 - 1 Mark)

12. Write down the balanced equations for the reactions when:

(i) a mixture of potassium chlorate, oxalic acid and sulphuric acid is heated; (1985 - 1 Mark)

(ii) ammonium sulphate is heated with a mixture of nitric oxide and nitrogen dioxide. (1985 - 1 Mark)

13. What happens when :

(i) hydrogen sulphide is bubbled through an aqueous solution of sulphur dioxide. (1985 - 1 Mark)

(ii) tin is treated with concentrated nitric acid. (1985 - 1 Mark)

(iii)  $\text{Pb}_3\text{O}_4$  is treated with nitric acid. (1985 - 1 Mark)

14. Arrange the following in :

(i) increasing bond strength HCl, HBr, HF, HI (1986 - 1 Mark)

(ii)  $\text{HOCl}$ ,  $\text{HOClO}_2$ ,  $\text{HOClO}_3$ ,  $\text{HOClO}$  in increasing order of thermal stability. (1988 - 1 Mark)

(iii)  $\text{CO}_2$ ,  $\text{N}_2\text{O}_5$ ,  $\text{SiO}_2$ ,  $\text{SO}_3$  in the order of increasing acidic character. (1988 - 1 Mark)

(iv) Increasing order of extent of hydrolysis :

$\text{CCl}_4$ ,  $\text{MgCl}_2$ ,  $\text{AlCl}_3$ ,  $\text{PCl}_5$ ,  $\text{SiCl}_4$  (1991 - 1 Mark)

15. Mention the products formed in the following :

(i) Chlorine gas is bubbled through a solution of ferrous bromide. (1986 - 1 Mark)

(ii) Iodine is added to a solution of stannous chloride. (1986 - 1 Mark)

(iii) Sulphur dioxide gas, water vapour and air are passed over heated sodium chloride. (1986 - 1 Mark)

16. Write the two resonance structures of ozone which satisfy the octet rule. (1991 - 1 Mark)

17.  $\text{PbS} \xrightarrow[\text{air}]{\text{heat in}} \text{A} + \text{PbS} \xrightarrow{\text{B}} \text{Pb} + \text{SO}_2$ ; Identify A and B. (1991 - 2 Marks)

18. Complete and balance the following chemical reactions :

(i) Red phosphorus is reacted with iodine in presence of water. (1992 - 1 Mark)

$\text{P} + \text{I}_2 + \text{H}_2\text{O} \rightarrow \dots + \dots$

(ii) Anhydrous potassium nitrate is heated with excess of metallic potassium. (1992 - 1 Mark)

$\text{KNO}_3(\text{s}) + \text{K}(\text{s}) \rightarrow \dots + \dots$

(iii)  $\text{NH}_3 + \text{NaOCl} \rightarrow \dots + \dots$  (1993 - 1 Mark)

(iv)  $\text{Sn} + 2\text{KOH} + 4\text{H}_2\text{O} \rightarrow \dots + \dots$  (1994 - 1 Mark)

19. Draw the structure of  $\text{P}_4\text{O}_{10}$  and identify the number of single and double P—O bonds. (1996 - 3 Marks)

20. Gradual addition of KI solution to  $\text{Bi}(\text{NO}_3)_3$  solution initially produces a dark brown precipitate which dissolves in excess of KI to give a clear yellow solution. Write chemical equations for the above reactions. (1996 - 2 Marks)

21. Complete the following chemical equations :

(a)  $\text{KI} + \text{Cl}_2 \rightarrow$  (b)  $\text{KClO}_3 + \text{I}_2 \rightarrow$

Justify the formation of the products in the above reactions. (1996 - 2 Marks)

22. A soluble compound of a poisonous element M, when heated with  $\text{Zn}/\text{H}_2\text{SO}_4$  gives a colourless and extremely poisonous gaseous compound N, which on passing through a heated tube gives a silvery mirror of element M. Identify M and N. (1997 - 2 Marks)

23. Draw the structure of a cyclic silicate,  $(\text{Si}_3\text{O}_9)^{6-}$  with proper labelling. (1998 - 4 Marks)

24. Thionyl chloride can be synthesized by chlorinating  $\text{SO}_2$  using  $\text{PCl}_5$ . Thionyl chloride is used to prepare anhydrous ferric chloride starting from its hexahydrated salt. Alternatively, the anhydrous ferric chloride can also be prepared from its hexahydrated salt by treating with 2, 2 - dimethoxypropane. Discuss all this using balanced chemical equations. (1998 - 6 Marks)

25. Reaction of phosphoric acid with  $\text{Ca}_5(\text{PO}_4)_3\text{F}$  yields a fertilizer "triple superphosphate". Represent the same through balanced chemical equation. (1998 - 2 Marks)
26. In the following equation, (1999 - 6 Marks)  
 $\text{A} + 2\text{B} + \text{H}_2\text{O} \rightarrow \text{C} + 2\text{D}$   
 (A =  $\text{HNO}_2$ , B =  $\text{H}_2\text{SO}_3$ , C =  $\text{NH}_2\text{OH}$ ). Identify D. Draw the structures of A, B, C and D.
27. In the contact process for industrial manufacture of sulphuric acid some amount of sulphuric acid is used as a starting material. Explain briefly. What is the catalyst used in the oxidation of  $\text{SO}_2$ ? (1999 - 4 Marks)
28. The Haber process can be represented by the following scheme;

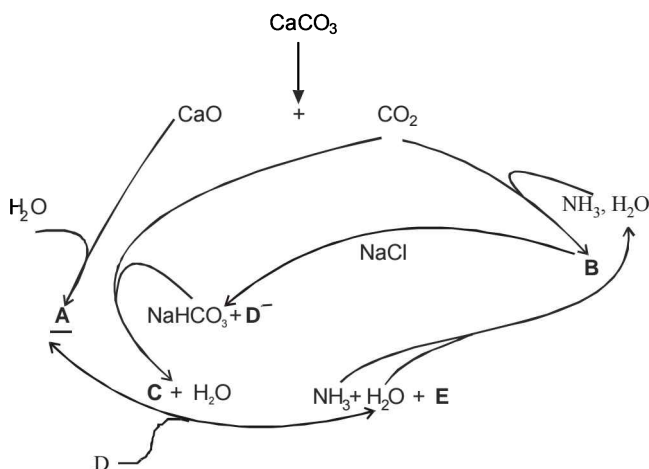

Identify A, B, C, D and E. (1999 - 5 Marks)

29. Give an example of oxidation of one halide by another halogen. Explain the feasibility of the reaction (2000 - 2 Marks).
30. Draw the molecular structures of  $\text{XeF}_2$ ,  $\text{XeF}_4$  and  $\text{XeO}_2\text{F}_2$  indicating the location of lone pair(s) of electrons. (2000 - 3 Marks)
31. Give reason(s) why elemental nitrogen exists as a diatomic molecule whereas elemental phosphorus as a tetraatomic molecule. (2000 - 2 Marks)
32. Compound (X) on reduction with  $\text{LiAlH}_4$  gives a hydride (Y) containing 21.72% hydrogen along with other products. The compound (Y) reacts with air explosively resulting in boron trioxide. Identify (X) and (Y). Give balanced reactions involved in the formation of (Y) and its reaction with air. Draw the structure of (Y). (2001 - 5 Marks)
33. Starting from  $\text{SiCl}_4$ , prepare the following in steps not exceeding the number given in parentheses (give reactions only):  
 (i) Silicon (1)  
 (ii) Linear silicone containing methyl groups only (4)  
 (iii)  $\text{Na}_2\text{SiO}_3$  (3) (2001 - 5 Marks)
34. Write balanced equations for the reactions of the following compounds with water : (2002 - 5 Marks)  
 (i)  $\text{Al}_4\text{C}_3$   
 (ii)  $\text{CaNCN}$   
 (iii)  $\text{BF}_3$   
 (iv)  $\text{NCl}_3$   
 (v)  $\text{XeF}_4$
35. How is boron obtained from borax? Give chemical equations with reaction conditions. Write the structure of  $\text{B}_2\text{H}_6$  and its reaction with  $\text{HCl}$ . (2002 - 5 Marks)
36. Write down reactions involved in the extraction of Pb. What is the oxidation number of lead in litharge? (2003 - 2 Marks)
37. Identify the following: (2003 - 4 Marks)  

$$\text{Na}_2\text{CO}_3 \xrightarrow{\text{SO}_2} \text{A} \xrightarrow{\text{Na}_2\text{CO}_3} \text{B} \xrightarrow[\Delta]{\text{Elemental S}} \text{C} \xrightarrow{\text{I}_2} \text{D}$$
- Also mention the oxidation state of S in all the compounds.
38.  $\text{AlF}_3$  is insoluble in anhydrous  $\text{HF}$  but it becomes soluble in presence of little amount of  $\text{KF}$ . Addition of boron trifluoride to the resulting solution causes reprecipitation of  $\text{AlF}_3$ . Explain with balanced chemical equations. (2004 - 2 Marks)
39. How many grams of  $\text{CaO}$  are required to neutralize 852 gm of  $\text{P}_4\text{O}_{10}$ ? Draw structure of  $\text{P}_4\text{O}_{10}$  molecule. (2005 - 2 Marks)
40. Write the structures of  $(\text{CH}_3)_3\text{N}$  and  $(\text{Me}_3\text{Si})_3\text{N}$ . Are they isostructural? Justify your answer. (2005 - 2 Marks)
41.  $(\text{B}) \xleftarrow{\text{NaBr} + \text{MnO}_2} (\text{A}) \xrightarrow{\text{Conc. HNO}_3} (\text{C})$

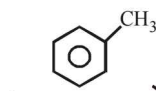

$\xrightarrow{\hspace{2cm}}$  (D) (explosive product)

Identify the missing compounds. Give the equation from A to B and A to C. (2005 - 4 Marks)



## F Match the Following

**DIRECTIONS (Q. 1 to 3) :** Each question contains statements given in two columns, which have to be matched. The statements in Column-I are labelled A, B, C and D, while the statements in Column-II are labelled p, q, r, s and t. Any given statement in Column-I can have correct matching with ONE OR MORE statement(s) in Column-II. The appropriate bubbles corresponding to the answers to these questions have to be darkened as illustrated in the following example :

If the correct matches are A-p, s and t; B-q and r; C-p and q; and D-s then the correct darkening of bubbles will look like the given.

	p	q	r	s	t
A	<input checked="" type="checkbox"/>	<input checked="" type="checkbox"/>	<input type="checkbox"/>	<input checked="" type="checkbox"/>	<input checked="" type="checkbox"/>
B	<input type="checkbox"/>	<input checked="" type="checkbox"/>	<input checked="" type="checkbox"/>	<input type="checkbox"/>	<input type="checkbox"/>
C	<input checked="" type="checkbox"/>	<input checked="" type="checkbox"/>	<input type="checkbox"/>	<input type="checkbox"/>	<input type="checkbox"/>
D	<input type="checkbox"/>	<input type="checkbox"/>	<input type="checkbox"/>	<input checked="" type="checkbox"/>	<input type="checkbox"/>

1. Match gases under specified conditions listed in **Column I** with their properties/laws in **Column II**. Indicate your answer by darkening the appropriate bubbles of the  $4 \times 4$  matrix given in the ORS. (1995S)

**Column I**

- (A) Explosive  
(B) Artificial gem  
(C) Self reduction  
(D) Magnetic material

**Column II**

- (p)  $\text{NaN}_3$   
(q)  $\text{Fe}_3\text{O}_4$   
(r) Cu  
(s)  $\text{Al}_2\text{O}_3$   
(t)  $\text{Pb}(\text{N}_3)_2$   
(u)  $\text{Fe}_2\text{O}_3$   
(v) Cu  
(w) SiC

2. Match the following :

**Column I**

- (A)  $\text{Bi}^{3+} \longrightarrow (\text{BiO})^+$   
(B)  $[\text{AlO}_2]^- \longrightarrow \text{Al}(\text{OH})_3$   
(C)  $[\text{SiO}_4]^{4-} \longrightarrow [\text{Si}_2\text{O}_7]^{6-}$   
(D)  $[\text{B}_4\text{O}_7]^{2-} \longrightarrow [\text{B}(\text{OH})_3]$

**Column II**

- (p) Heat  
(q) Hydrolysis  
(r) Acidification  
(s) Dilution by water

3. Match each of the diatomic molecules in **Column I** with its property/properties in **Column II**. (2009)

**Column I**

- (A)  $\text{B}_2$   
(B)  $\text{N}_2$   
(C)  $\text{O}_2^-$   
(D)  $\text{O}_2$

**Column II**

- (p) Paramagnetic  
(q) Undergoes oxidation  
(r) Undergoes reduction  
(s) Bond order  $\geq 2$   
(t) Mixing of 's' and 'p' orbital

**DIRECTIONS (for Q. 4) :** Following question has matching lists. The codes for the lists have choices (a), (b), (c) and (d) out of which ONLY ONE is correct.

4. The unbalanced chemical reactions given in List I show missing reagent or condition (?) which are provided in List II. Match List I with List II and select the correct answer using the code given below the lists (JEE Adv. 2013-II)

**List I**

- P.  $\text{PbO}_2 + \text{H}_2\text{SO}_4 \xrightarrow{?} \text{PbSO}_4 + \text{O}_2 + \text{other product}$   
Q.  $\text{Na}_2\text{S}_2\text{O}_3 + \text{H}_2\text{O} \xrightarrow{?} \text{NaHSO}_4 + \text{other product}$   
R.  $\text{N}_2\text{H}_4 \xrightarrow{?} \text{N}_2 + \text{other product}$   
S.  $\text{XeF}_2 \xrightarrow{?} \text{Xe} + \text{other product}$

**List II**

1. NO  
2.  $\text{I}_2$   
3. Warm  
4.  $\text{Cl}_2$

**Codes :**

	P	Q	R	S
(a)	4	2	3	1
(b)	3	2	1	4
(c)	1	4	2	3
(d)	3	4	2	1

## G Comprehension Based Questions

### PASSAGE - 1

The noble gases have closed-shell electronic configuration and are monoatomic gases under normal conditions. The low boiling points of the lighter noble gases are due to weak dispersion forces between the atoms and the absence of other interatomic interactions.

The direct reaction of xenon with fluorine leads to a series of compounds with oxidation numbers +2, +4 and +6.  $\text{XeF}_4$  reacts violently with water to give  $\text{XeO}_3$ . The compounds of xenon exhibit rich stereochemistry and their geometries can be deduced considering the total number of electron pairs in the valence shell.

- Argon is used in arc welding because of its (2007)
  - low reactivity with metal
  - ability to lower the melting point of metal
  - flammability
  - high calorific value
- The structure of  $\text{XeO}_3$  is (2007)
  - linear
  - planar
  - pyramidal
  - T-shaped
- $\text{XeF}_4$  and  $\text{XeF}_6$  are expected to be (2007)
  - oxidizing
  - reducing
  - unreactive
  - strongly basic

### PASSAGE - 2

There are some deposits of nitrates and phosphates in earth's crust. Nitrates are more soluble in water. Nitrates are difficult to reduce under the laboratory conditions but microbes do it easily. Ammonia forms large number of complexes with transition metal ions. Hybridization easily explains the ease of sigma donation capability of  $\text{NH}_3$  and  $\text{PH}_3$ . Phosphine is a flammable gas and is prepared from white phosphorous.

- Among the following, the correct statement is (2008)
  - Phosphates have no biological significance in humans
  - Between nitrates and phosphates, phosphates are less abundant in earth's crust
  - Between nitrates and phosphates, nitrates are less abundant in earth's crust
  - Oxidation of nitrates is possible in soil
- Among the following, the correct statement is
  - Between  $\text{NH}_3$  and  $\text{PH}_3$ ,  $\text{NH}_3$  is a better electron donor because the lone pair of electrons occupies spherical s-orbital and is less directional
  - Between  $\text{NH}_3$  and  $\text{PH}_3$ ,  $\text{PH}_3$  is a better electron donor because the lone pair of electrons occupies  $\text{sp}^3$  orbital and is more directional

(c) Between  $\text{NH}_3$  and  $\text{PH}_3$ ,  $\text{NH}_3$  is a better electron donor because the lone pair of electrons occupies  $\text{sp}^3$  orbital and is more directional

(d) Between  $\text{NH}_3$  and  $\text{PH}_3$ ,  $\text{PH}_3$  is a better electron donor because the lone pair of electrons occupies spherical s-orbital and is less directional

- White phosphorus on reaction with  $\text{NaOH}$  gives  $\text{PH}_3$  as one of the products. This is a
  - dimerization reaction
  - disproportionation reaction
  - condensation reaction
  - precipitation reaction

### PASSAGE - 3

Bleaching powder and bleach solution are produced on a large scale and used in several household products. The effectiveness of bleach solution is often measured by iodometry. (2012 - II)

- Bleaching powder contains a salt of an oxoacid as one of its components. The anhydride of that oxoacid is
  - $\text{Cl}_2\text{O}$
  - $\text{Cl}_2\text{O}_7$
  - $\text{ClO}_2$
  - $\text{Cl}_2\text{O}_6$
- 25 mL of household solution was mixed with 30 mL of 0.50 M  $\text{KI}$  and 10 mL of 4N acetic acid. In the titration of the liberated iodine, 48 mL of 0.25 N  $\text{Na}_2\text{S}_2\text{O}_3$  was used to reach the end point. The molarity of the household bleach solution is
  - 0.48 M
  - 0.96 M
  - 0.24 M
  - 0.024 M

### PASSAGE - 4

The reactions of  $\text{Cl}_2$  gas with cold-dilute and hot-concentrated  $\text{NaOH}$  in water give sodium salts of two (different) oxoacids of chlorine, P and Q, respectively. The  $\text{Cl}_2$  gas reacts with  $\text{SO}_2$  gas, in presence of charcoal, to give a product R. R reacts with white phosphorus to give a compound S. On hydrolysis, S gives an oxoacid of phosphorus, T. (JEE Adv. 2013)

- P and Q, respectively, are the sodium salts of
  - Hypochlorous and chloric acids
  - Hypochlorous and chlorous acids
  - Chloric and perchloric acids
  - Chloric and hypochlorous acids
- R, S and T respectively, are
  - $\text{SO}_2\text{Cl}_2$ ,  $\text{PCl}_5$  and  $\text{H}_3\text{PO}_4$
  - $\text{SO}_2\text{Cl}_2$ ,  $\text{PCl}_3$  and  $\text{H}_3\text{PO}_3$
  - $\text{SOCl}_2$ ,  $\text{PCl}_3$  and  $\text{H}_3\text{PO}_2$
  - $\text{SOCl}_2$ ,  $\text{PCl}_5$  and  $\text{H}_3\text{PO}_4$

## H Assertion & Reason Type Questions

This question contains STATEMENT-1 (Assertion/ Statement) and STATEMENT-2 (Reason/Explanation) and has 4 choices (a), (b), (c) and (d) out of which ONLY ONE is correct.

- (a) Statement-1 is True, Statement-2 is True; Statement-2 is a correct explanation for Statement-1  
 (b) Statement-1 is True, Statement-2 is True; Statement-2 is NOT a correct explanation for Statement-1  
 (c) Statement-1 is True, Statement-2 is False  
 (d) Statement-1 is False, Statement-2 is True.

1. **Statement-1** : Although  $\text{PF}_5$ ,  $\text{PCl}_5$  and  $\text{PBr}_5$  are known, the pentahalides of nitrogen have not been observed

**Statement-2** : Phosphorus has lower electronegativity than nitrogen. (1994 - 2 Marks)

2. **Statement-1** : F atom has less electron affinity than Cl atom.

**Statement-2** : Additional electrons are repelled more effectively by  $3p$  electrons in Cl atom than by  $2p$  electrons in F atom. (1998 - 2 Marks)

3. **Statement-1** :  $\text{Al}(\text{OH})_3$  is amphoteric in nature

**Statement-2** : Al–O and O–H bonds can be broken with equal ease in  $\text{Al}(\text{OH})_3$ . (1998 - 2 Marks)

4. **Statement-1** : Between  $\text{SiCl}_4$  and  $\text{CCl}_4$ , only  $\text{SiCl}_4$  reacts with water.

**Statement-2** :  $\text{SiCl}_4$  is ionic and  $\text{CCl}_4$  is covalent.

(2001S)

5. **Statement-1** : In water, orthoboric acid behaves as a weak monobasic acid. because

**Statement-2** : In water, orthoboric acid acts as a proton donor. (2007)

6. **Statement-1** : Boron always forms covalent bond. because

**Statement-2** : The small size of  $\text{B}^{3+}$  favours formation of covalent bond. (2007)

7. **Statement-1** :  $\text{Pb}^{+4}$  compounds are stronger oxidising agents than  $\text{Sn}^{+4}$  compounds (2008)

**Statement-2** : The higher oxidation states for the group 14 elements are more stable for the heavier members of the group due to 'inert pair effect'.

## I Integer Value Correct Type

1. The coordination number of Al in the crystalline state of  $\text{AlCl}_3$  is (2009)

2. The value of  $n$  in the molecular formula  $\text{Be}_n\text{Al}_2\text{Si}_6\text{O}_{18}$  is (2010)

3. Reaction of  $\text{Br}_2$  with  $\text{Na}_2\text{CO}_3$  in aqueous solution gives sodium bromide and sodium bromate with evolution of  $\text{CO}_2$  gas. The number of sodium bromide molecules involved in the balanced chemical equation is (2011)

4. Among the following, the number of compounds that can react with  $\text{PCl}_5$  to give  $\text{POCl}_3$  is (2011)  
 $\text{O}_2$ ,  $\text{CO}_2$ ,  $\text{SO}_2$ ,  $\text{H}_2\text{O}$ ,  $\text{H}_2\text{SO}_4$ ,  $\text{P}_4\text{O}_{10}$

5. The total number of lone pairs of electrons in  $\text{N}_2\text{O}_3$  is (JEE Adv. 2015)

6. Three moles of  $\text{B}_2\text{H}_6$  are completely reacted with methanol. The number of moles of boron containing product formed is (JEE Adv. 2015)

## Section-B

## JEE Main / AIEEE

- Alum helps in purifying water by [2002]
  - forming Si complex with clay partiles
  - sulphate part which combines with the dirt and removes it
  - coagulaing the mud particles
  - making mud water soluble.
- In  $\text{XeF}_2$ ,  $\text{XeF}_4$ ,  $\text{XeF}_6$  the number of lone pairs on Xe are respectively [2002]
  - 2, 3, 1
  - 1, 2, 3
  - 4, 1, 2
  - 3, 2, 1.
- In case of nitrogen,  $\text{NCl}_3$  is possible but not  $\text{NCl}_5$  while in case of phosphorous,  $\text{PCl}_3$  as well as  $\text{PCl}_5$  are possible. It is due to [2002]
  - availability of vacant  $d$  orbitals in P but not in N
  - lower electronegativity of P than N
  - lower tendency of H-bond formation in P than N
  - occurrence of P in solid while N in gaseous state at room temperature.
- Which of the following statements is true? [2002]
  - HF is less polar than HBr
  - absolutely pure water does not contain any ions
  - chemical bond formation take place when forces of attraction overcome the forces of repulsion
  - in covalency transference of electron takes place.
- Number of sigma bonds in  $\text{P}_4\text{O}_{10}$  is [2002]
  - 6
  - 7
  - 17
  - 16.
- Oxidation number of Cl in  $\text{CaOCl}_2$  (bleaching power) is: [2002]
  - zero, since it contains  $\text{Cl}_2$
  - 1, since it contains  $\text{Cl}^-$
  - +1, since it contains  $\text{ClO}^-$
  - +1 and -1 since it contains  $\text{ClO}^-$  and  $\text{Cl}^-$
- What may be expected to happen when phosphine gas is mixed with chlorine gas ? [2003]
  - $\text{PCl}_3$  and HCl are formed and the mixture warms up
  - $\text{PCl}_5$  and HCl are formed and the mixture cools down
  - $\text{PH}_3 \cdot \text{Cl}_2$  is formed with warming up
  - The mixture only cools down
- Concentrated hydrochloric acid when kept in open air sometimes produces a cloud of white fumes. The explanation for it is that [2003]
  - oxygen in air reacts with the emitted HCl gas to form a cloud of chlorine gas
  - strong affinity of HCl gas for moisture in air results in forming of droplets of liquid solution which appears like a cloudy smoke.
  - due to strong affinity for water, concentrated hydrochloric acid pulls moisture of air towards itself. This moisture forms droplets of water and hence the cloud.
  - concentrated hydrochloric acid emits strongly smelling HCl gas all the time.
- Graphite is a soft solid lubricant extremely difficult to melt. The reason for this anomalous behaviour is that graphite [2003]
  - is an allotropic form of diamond
  - has molecules of variable molecular masses like polymers
  - has carbon atoms arranged in large plates of rings of strongly bound carbon atoms with weak interplate bonds
  - is a non-crystalline substance
- Glass is a [2003]
  - super-cooled liquid
  - gel
  - polymeric mixture
  - micro-crystalline solid
- Which one of the following substances has the highest proton affinity ? [2003]
  - $\text{H}_2\text{S}$
  - $\text{NH}_3$
  - $\text{PH}_3$
  - $\text{H}_2\text{O}$
- For making good quality mirrors, plates of float glass are used. These are obtained by floating molten glass over a liquid metal which does not solidify before glass. The metal used can be [2003]
  - tin
  - sodium
  - magnesium
  - mercury

13. Which among the following factors is the most important in making fluorine the strongest oxidizing halogen ? [2004]
- Hydration enthalpy
  - Ionization enthalpy
  - Electron affinity
  - Bond dissociation energy
14. Which one of the following statement regarding helium is **incorrect** ? [2004]
- It is used to produce and sustain powerful superconducting magnets
  - It is used as a cryogenic agent for carrying out experiments at low temperatures
  - It is used to fill gas balloons instead of hydrogen because it is lighter and non-inflammable
  - It is used in gas-cooled nuclear reactors
15. Beryllium and aluminium exhibit many properties which are similar. But, the two elements differ in [2004]
- forming covalent halides
  - forming polymeric hydrides
  - exhibiting maximum covalency in compounds
  - exhibiting amphoteric nature in their oxides
16. Aluminium chloride exists as dimer,  $\text{Al}_2\text{Cl}_6$  in solid state as well as in solution of non-polar solvents such as benzene. When dissolved in water, it gives [2004]
- $[\text{Al}(\text{OH})_6]^{3-} + 3\text{HCl}$
  - $[\text{Al}(\text{H}_2\text{O})_6]^{3+} + 3\text{Cl}^-$
  - $\text{Al}^{3+} + 3\text{Cl}^-$
  - $\text{Al}_2\text{O}_3 + 6\text{HCl}$
17. Excess of KI reacts with  $\text{CuSO}_4$  solution and then  $\text{Na}_2\text{S}_2\text{O}_3$  solution is added to it. Which of the statements is **incorrect** for this reaction ? [2004]
- $\text{Na}_2\text{S}_2\text{O}_3$  is oxidised
  - $\text{CuI}_2$  is formed
  - $\text{Cu}_2\text{I}_2$  is formed
  - Evolved  $\text{I}_2$  is reduced
18. The number of hydrogen atom(s) attached to phosphorus atom in hypophosphorous acid is [2005]
- three
  - one
  - two
  - zero
19. The correct order of the thermal stability of hydrogen halides ( $\text{H}-\text{X}$ ) is [2005]
- $\text{HI} > \text{HCl} < \text{HF} > \text{HBr}$
  - $\text{HCl} < \text{HF} > \text{HBr} < \text{HI}$
  - $\text{HF} > \text{HCl} < \text{HBr} > \text{HI}$
  - $\text{HI} < \text{HBr} > \text{HCl} < \text{HF}$
20. Heating an aqueous solution of aluminium chloride to dryness will give [2005]
- $\text{Al}(\text{OH})\text{Cl}_2$
  - $\text{Al}_2\text{O}_3$
  - $\text{Al}_2\text{Cl}_6$
  - $\text{AlCl}_3$
21. In silicon dioxide [2005]
- there are double bonds between silicon and oxygen atoms
  - silicon atom is bonded to two oxygen atoms
  - each silicon atom is surrounded by two oxygen atoms and each oxygen atom is bonded to two silicon atoms
  - each silicon atom is surrounded by four oxygen atoms and each oxygen atom is bonded to two silicon atoms.
22. The structure of diborane ( $\text{B}_2\text{H}_6$ ) contains [2005]
- four 2c-2e bonds and four 3c-2e bonds
  - two 2c-2e bonds and two 3c-3e bonds
  - two 2c-2e bonds and four 3c-2e bonds
  - four 2c-2e bonds and two 3c-2e bonds
23. Which of the following statements is true? [2006]
- $\text{HClO}_4$  is a weaker acid than  $\text{HClO}_3$
  - $\text{HNO}_3$  is a stronger acid than  $\text{HNO}_2$
  - $\text{H}_3\text{PO}_3$  is a stronger acid than  $\text{H}_2\text{SO}_3$
  - In aqueous medium HF is a stronger acid than HCl
24. The increasing order of the first ionization enthalpies of the elements B, P, S and F (Lowest first) is [2006]
- $\text{B} < \text{P} < \text{S} < \text{F}$
  - $\text{B} < \text{S} < \text{P} < \text{F}$
  - $\text{F} < \text{S} < \text{P} < \text{B}$
  - $\text{P} < \text{S} < \text{B} < \text{F}$
25. What products are expected from the disproportionation reaction of hypochlorous acid? [2006]
- HCl and  $\text{Cl}_2\text{O}$
  - HCl and  $\text{HClO}_3$
  - $\text{HClO}_3$  and  $\text{Cl}_2\text{O}$
  - $\text{HClO}_2$  and  $\text{HClO}_4$
26. Identify the incorrect statement among the following. [2007]
- $\text{Br}_2$  reacts with hot and strong NaOH solution to give NaBr and  $\text{H}_2\text{O}$ .
  - Ozone reacts with  $\text{SO}_2$  to give  $\text{SO}_3$ .
  - Silicon reacts with  $\text{NaOH}_{(\text{aq})}$  in the presence of air to give  $\text{Na}_2\text{SiO}_3$  and  $\text{H}_2\text{O}$ .
  - $\text{Cl}_2$  reacts with excess of  $\text{NH}_3$  to give  $\text{N}_2$  and HCl.

27. Regular use of the following fertilizers increases the acidity of soil? [2007]
- Ammonium sulphate
  - Potassium nitrate
  - Urea
  - Superphosphate of lime.
28. Which one of the following is the correct statement? [2008]
- Boric acid is a protonic acid
  - Beryllium exhibits coordination number of six
  - Chlorides of both beryllium and aluminium have bridged chloride structures in solid phase
  - $B_2H_6 \cdot 2NH_3$  is known as 'inorganic benzene'
29. Which one of the following reactions of xenon compounds is not feasible? [2009]
- $3XeF_4 + 6H_2O \longrightarrow 2Xe + XeO_3 + 12HF + 1.5O_2$
  - $2XeF_2 + 2H_2O \longrightarrow 2Xe + 4HF + O_2$
  - $XeF_6 + RbF \longrightarrow Rb[XeF_7]$
  - $XeO_3 + 6HF \longrightarrow XeF_6 + 3H_2O$
30. Which of the following statement is wrong? [2011]
- The stability of hydride increases from  $NH_3$  to  $BiH_3$  in group 15 of the periodic table.
  - Nitrogen cannot form  $d\pi - p\pi$  bond.
  - Single N-N bond is weaker than the single P-P bond.
  - $N_2O_4$  has two resonance structures.
31. Which of the following statements regarding sulphur is incorrect? [2011]
- $S_2$  molecule is paramagnetic.
  - The vapour at  $200^\circ C$  consists mostly of  $S_8$  rings.
  - At  $600^\circ C$  the gas mainly consists of  $S_2$  molecules.
  - The oxidation state of sulphur is never less than +4 in its compounds.
32. Boron cannot form which one of the following anions? [2011]
- $BF_6^{3-}$
  - $BH_4^-$
  - $B(OH)_4^-$
  - $BO_2^-$
33. The molecule having smallest bond angle is : [2012]
- $NCl_3$
  - $AsCl_3$
  - $SbCl_3$
  - $PCl_3$
34. Among the following oxoacids, the correct decreasing order of acid strength is: [JEE M 2014]
- $HOCl > HClO_2 > HClO_3 > HClO_4$
  - $HClO_4 > HOCl > HClO_2 > HClO_3$
  - $HClO_4 > HClO_3 > HClO_2 > HOCl$
  - $HClO_2 > HClO_4 > HClO_3 > HOCl$
35. Which one of the following properties is **not** shown by NO? [JEE M 2014]
- It is diamagnetic in gaseous state
  - It is neutral oxide
  - It combines with oxygen to form nitrogen dioxide
  - Its bond order is 2.5
36. The correct statement for the molecule,  $CsI_3$  is: [JEE M 2014]
- It is a covalent molecule.
  - It contains  $Cs^+$  and  $I_3^-$  ions.
  - It contains  $Cs^{3+}$  and  $I^-$  ions.
  - It contains  $Cs^+$ ,  $I^-$  and lattice  $I_2$  molecule.
37. Which among the following is the most reactive? [JEE M 2015]
- $I_2$
  - $ICl$
  - $Cl_2$
  - $Br_2$
38. **Assertion:** Nitrogen and oxygen are the main components in the atmosphere but these do not react to form oxides of nitrogen.  
**Reason:** The reaction between nitrogen and oxygen requires high temperature. [JEE M 2015]
- The assertion is incorrect, but the reason is correct
  - Both the assertion and reason are incorrect
  - Both assertion and reason are correct, and the reason is the correct explanation for the assertion
  - Both assertion and reason are correct, but the reason is not the correct explanation for the assertion
39. Which one has the highest boiling point? [JEE M 2015]
- Kr
  - Xe
  - He
  - Ne
40. The pair in which phosphorous atoms have a formal oxidation state of +3 is: [JEE M 2016]
- Orthophosphorous and hypophosphoric acids
  - Pyrophosphorous and pyrophosphoric acids
  - Orthophosphorous and pyrophosphorous acids
  - Pyrophosphorous and hypophosphoric acids
41. The reaction of zinc with dilute and concentrated nitric acid, respectively, produces: [JEE M 2016]
- NO and  $N_2O$
  - $NO_2$  and  $N_2O$
  - $N_2O$  and  $NO_2$
  - $NO_2$  and NO

## CHAPTER

## 17

## The d- and f-Block Elements and Co-ordination Compounds

## Section-A

## JEE Advanced/ IIT-JEE

## A Fill in the Blanks

- AgCN dissolves in excess KCN solution to give the complex compound ..... (1980)
- Mn<sup>2+</sup> can be oxidised to MnO<sub>4</sub><sup>-</sup> by ..... (SnO<sub>2</sub>, PbO<sub>2</sub>, BaO<sub>2</sub>) (1981 - 1 Mark)
- Galvanization of iron denotes coating with ..... (1983 - 1 Mark)
- Silver chloride is sparingly soluble in water because its lattice energy is greater than ..... energy. (1987 - 1 Mark)
- The salts ..... and ..... are isostructural. (FeSO<sub>4</sub>·7H<sub>2</sub>O, CuSO<sub>4</sub>·5H<sub>2</sub>O, MnSO<sub>4</sub>·4H<sub>2</sub>O, ZnSO<sub>4</sub>·7H<sub>2</sub>O) (1988 - 1 Mark)
- The type of magnetism exhibited by [Mn(H<sub>2</sub>O)<sub>6</sub>]<sup>2+</sup> ion is ..... (1994 - 1 Mark)
- The IUPAC name of [Co(NH<sub>3</sub>)<sub>6</sub>]Cl<sub>3</sub> is ..... (1994 - 1 Mark)
- When Fe(s) is dissolved in aqueous hydrochloric acid in a closed vessel, the work done is ..... (1997 - 1 Mark)
- Silver jewellery items tarnish slowly in the air due to their reaction with ..... (1997 - 1 Mark)
- Which of the following is the weakest base (1980)
  - NaOH
  - Ca(OH)<sub>2</sub>
  - KOH
  - Zn(OH)<sub>2</sub>
- One of the constituent of German silver is (1980)
  - Ag
  - Cu
  - Mg
  - Al
- Which of the following dissolve in hot conc. NaOH solution
  - Fe
  - Zn
  - Cu
  - Ag (1980)
- How many unpaired electrons are present in Ni<sup>2+</sup>?
  - 0
  - 2
  - 4
  - 8 (1981 - 1 Mark)
- Sodium thiosulphate is used in photography because of its
  - reducing behaviour
  - oxidising behaviour
  - complex forming behaviour
  - reaction with light (1981 - 1 Mark)
- Iron is rendered passive by treatment with concentrated
  - H<sub>2</sub>SO<sub>4</sub>
  - H<sub>3</sub>PO<sub>4</sub>
  - HCl
  - HNO<sub>3</sub> (1982 - 1 Mark)
- In the metallurgy of iron, when limestone is added to the blast furnace, the calcium ion ends up in
  - slag
  - gangue
  - metallic calcium
  - calcium carbonate (1982 - 1 Mark)
- Zinc-copper couple that can be used as a reducing agent is obtained by :
  - mixing zinc dust and copper gauze
  - zinc coated with copper
  - copper coated with zinc
  - zinc and copper wires welded together (1984 - 1 Mark)

## B True / False

- Copper metal reduces Fe<sup>2+</sup> in an acid medium. (1982 - 1 Mark)
- Silver fluoride is fairly soluble in water. (1982 - 1 Mark)
- Silver chloride is more soluble in very concentrated sodium chloride solution than in pure water. (1984 - 1 Mark)
- Dipositive zinc exhibits paramagnetism due to loss of two electrons from 3d-orbital of neutral atom. (1987 - 1 Mark)
- Both potassium ferrocyanide and potassium ferricyanide are diamagnetic. (1989 - 1 Mark)
- Cu<sup>+</sup> disproportionates to Cu<sup>2+</sup> and elemental copper in solution. (1991 - 1 Mark)

## C MCQs with One Correct Answer

- When same amount of zinc is treated separately with excess of sulphuric acid and excess of sodium hydroxide, the ratio of volume of hydrogen evolved is (1979)
  - 1 : 1
  - 1 : 2
  - 2 : 1
  - 9 : 4
- Amongst the following, the lowest degree of paramagnetism per mole of the compound at 298 K will be shown by (1988 - 1 Mark)
  - MnSO<sub>4</sub>·4H<sub>2</sub>O
  - CuSO<sub>4</sub>·5H<sub>2</sub>O
  - FeSO<sub>4</sub>·6H<sub>2</sub>O
  - NiSO<sub>4</sub>·6H<sub>2</sub>O

11. Amongst  $\text{Ni}(\text{CO})_4$ ,  $[\text{Ni}(\text{CN})_4]^{2-}$  and  $\text{NiCl}_4^{2-}$  (1991 - 1 Mark)
- $\text{Ni}(\text{CO})_4$  and  $\text{NiCl}_4^{2-}$  are diamagnetic and  $[\text{Ni}(\text{CN})_4]^{2-}$  is paramagnetic
  - $\text{NiCl}_4^{2-}$  and  $[\text{Ni}(\text{CN})_4]^{2-}$  are diamagnetic and  $\text{Ni}(\text{CO})_4$  is paramagnetic
  - $\text{Ni}(\text{CO})_4$  and  $[\text{Ni}(\text{CN})_4]^{2-}$  are diamagnetic and  $\text{NiCl}_4^{2-}$  is paramagnetic
  - $\text{Ni}(\text{CO})_4$  is diamagnetic and  $\text{NiCl}_4^{2-}$  and  $[\text{Ni}(\text{CN})_4]^{2-}$  are paramagnetic
12. Which one is solder? (1995S)
- Cu & Pb
  - Zn & Cu
  - Pb & Sn
  - Fe & Zn
13. Which pair gives  $\text{Cl}_2$  at room temperature? (1995S)
- $\text{HCl}_{(\text{conc})} + \text{KMnO}_4$
  - $\text{NaCl} + \text{H}_2\text{SO}_{4(\text{conc})}$
  - $\text{NaCl} + \text{MnO}_2$
  - $\text{NaCl} + \text{HNO}_{3(\text{conc})}$
14. Which compound is formed when excess of KCN is added to aqueous solution of copper sulphate? (1996 - 1 Mark)
- $\text{Cu}(\text{CN})_2$
  - $\text{K}_2[\text{Cu}(\text{CN})_4]$
  - $\text{K}[\text{Cu}(\text{CN})_2]$
  - $\text{K}_3[\text{Cu}(\text{CN})_4]$
15. Which compound does not dissolve in hot, dilute  $\text{HNO}_3$ ? (1996 - 1 Mark)
- HgS
  - PbS
  - CuS
  - CdS
16. An aqueous solution of  $\text{FeSO}_4$ ,  $\text{Al}_2(\text{SO}_4)_3$  and chrome alum is heated with excess of  $\text{Na}_2\text{O}_2$  and filtered. The materials obtained are: (1996 - 1 Mark)
- a colourless filtrate and a green residue
  - a yellow filtrate and a green residue
  - a yellow filtrate and a brown residue
  - a green filtrate and a brown residue
17. Ammonium dichromate is used in some fireworks. The green coloured powder blown in the air is (1997 - 1 Mark)
- $\text{CrO}_3$
  - $\text{Cr}_2\text{O}_3$
  - Cr
  - $\text{CrO}(\text{O}_2)$
18. The number of moles of  $\text{KMnO}_4$  that will be needed to react with one mole of sulphite ion in acidic solution is (1997 - 1 Mark)
- $\frac{2}{5}$
  - $\frac{3}{5}$
  - $\frac{4}{5}$
  - 1
19. Which of the following is an organometallic compound? (1997 - 1 Mark)
- Lithium methoxide
  - Lithium acetate
  - Lithium dimethylamide
  - Methyl lithium.
20. Which of the following compounds is expected to be coloured? (1997 - 1 Mark)
- $\text{Ag}_2\text{SO}_4$
  - $\text{CuF}_2$
  - $\text{MgF}_2$
  - $\text{CuCl}$
21. In the dichromate anion, (1999 - 2 Marks)
- 4 Cr - O bonds are equivalent
  - 6 Cr - O bonds are equivalent
  - all Cr - O bonds are equivalent
  - all Cr - O bonds are nonequivalent
22. The geometry of  $\text{Ni}(\text{CO})_4$  and  $\text{Ni}(\text{PPh}_3)_2\text{Cl}_2$  are (1999 - 2 Marks)
- both square planar
  - tetrahedral and square planar, respectively
  - both tetrahedral
  - square planar and tetrahedral, respectively
23. The chemical processes in the production of steel from haematite ore involve (2000S)
- reduction
  - oxidation
  - reduction followed by oxidation
  - oxidation followed by reduction
24. The complex ion which has no 'd' electron in the central metal atom is (2001S)
- $[\text{MnO}_4]^-$
  - $[\text{Co}(\text{NH}_3)_6]^{3+}$
  - $[\text{Fe}(\text{CN})_6]^{3-}$
  - $[\text{Cr}(\text{H}_2\text{O})_6]^{3+}$
25. Anhydrous ferric chloride is prepared by (2002S)
- heating hydrated ferric chloride at a high temperature in a stream of air
  - heating metallic iron in a stream of dry chlorine gas
  - reaction of metallic iron with hydrochloric acid
  - reaction of metallic iron with nitric acid
26. When  $\text{MnO}_2$  is fused with  $\text{KOH}$ , a coloured compound is formed, the product and its colour is: (2003S)
- $\text{K}_2\text{MnO}_4$ , purple green
  - $\text{KMnO}_4$ , purple
  - $\text{Mn}_2\text{O}_3$ , brown
  - $\text{Mn}_3\text{O}_4$ , black
27. In the process of extraction of gold, (2003S)
- $$\text{Roasted gold ore} + \text{CN}^- + \text{H}_2\text{O} \xrightarrow{\text{O}_2} [\text{X}] + \text{OH}^-$$
- $$[\text{X}] + \text{Zn} \longrightarrow [\text{Y}] + \text{Au}$$
- Identify the complexes [X] and [Y]
- $\text{X} = [\text{Au}(\text{CN})_2]^-$ ,  $\text{Y} = [\text{Zn}(\text{CN})_4]^{2-}$
  - $\text{X} = [\text{Au}(\text{CN})_4]^{3-}$ ,  $\text{Y} = [\text{Zn}(\text{CN})_4]^{2-}$
  - $\text{X} = [\text{Au}(\text{CN})_2]^-$ ,  $\text{Y} = [\text{Zn}(\text{CN})_6]^{4-}$
  - $\text{X} = [\text{Au}(\text{CN})_4]^-$ ,  $\text{Y} = [\text{Zn}(\text{CN})_4]^{2-}$
28. The species having tetrahedral shape is (2004S)
- $[\text{PdCl}_4]^{2-}$
  - $[\text{Ni}(\text{CN})_4]^{2-}$
  - $[\text{Pd}(\text{CN})_4]^{2-}$
  - $[\text{NiCl}_4]^{2-}$
29. The spin magnetic moment of cobalt in the compound  $\text{Hg}[\text{Co}(\text{SCN})_4]$  is (2004S)
- $\sqrt{3}$
  - $\sqrt{8}$
  - $\sqrt{15}$
  - $\sqrt{24}$



30. The product of oxidation of  $I^-$  with  $MnO_4^-$  in alkaline medium is (2004S)  
 (a)  $IO_3^-$  (b)  $I_2$   
 (c)  $IO^-$  (d)  $IO_4^-$
31.  $(NH_4)_2Cr_2O_7$  on heating liberates a gas. The same gas will be obtained by (2004S)  
 (a) heating  $NH_4NO_2$   
 (b) heating  $NH_4NO_3$   
 (c) treating  $H_2O_2$  with  $NaNO_2$   
 (d) treating  $Mg_3N_2$  with  $H_2O$
32. Which pair of compounds is expected to show similar colour in aqueous medium? (2005S)  
 (a)  $FeCl_2$  and  $CuCl_2$  (b)  $VOCl_2$  and  $CuCl_2$   
 (c)  $VOCl_2$  and  $FeCl_2$  (d)  $FeCl_2$  and  $MnCl_2$
33. Which kind of isomerism is exhibited by octahedral  $Co(NH_3)_4Br_2Cl$ ? (2005S)  
 (a) Geometrical and Ionization  
 (b) Geometrical and Optical  
 (c) Optical and Ionization  
 (d) Geometrical only
34.  $CuSO_4$  decolourises on addition of  $KCN$ , the product formed is (2006 - 3M, -1)  
 (a)  $Cu^{2+}$  get reduced to form  $[Cu(CN)_4]^{3-}$   
 (b)  $[Cu(CN)_4]^{2-}$   
 (c)  $CuCN$  (d)  $Cu(CN)_2$
35. Among the following metal carbonyls, the C–O bond order is lowest in (2007)  
 (a)  $[Mn(CO)_6]^+$  (b)  $[Fe(CO)_5]$   
 (c)  $[Cr(CO)_6]$  (d)  $[V(CO)_6]^-$
36. Native silver metal forms a water soluble complex with a dilute aqueous solution of  $NaCN$  in the presence of  
 (a) nitrogen (b) oxygen (2008)  
 (c) carbon dioxide (d) argon
37. Among the following, the coloured compound is (2008)  
 (a)  $CuCl$   
 (b)  $K_3[Cu(CN)_4]$   
 (c)  $CuF_2$   
 (d)  $[Cu(CH_3CN)_4]BF_4$
38. The IUPAC name of  $[Ni(NH_3)_4][NiCl_4]$  is (2008)  
 (a) Tetrachloronickel (II) - tetraamminenickel (II)  
 (b) Tetraamminenickel (II) - tetrachloronickel (II)  
 (c) Tetraamminenickel (II) - tetrachloronickelate (II)  
 (d) Tetrachloronickel (II) - tetrachloronickelate (0) Ans. (C)
39. Both  $[Ni(CO)_4]$  and  $[Ni(CN)_4]^{2-}$  are diamagnetic. The hybridisations of nickel in these complexes, respectively, are (2008)  
 (a)  $sp^3$ ,  $sp^3$  (b)  $sp^3$ ,  $dsp^2$   
 (c)  $dsp^2$ ,  $sp^3$  (d)  $dsp^2$ ,  $sp^2$
40. The spin only magnetic moment value (in Bohr magneton units) of  $Cr(CO)_6$  is (2009)  
 (a) 0 (b) 2.84  
 (c) 4.90 (d) 5.92
41. The ionisation isomer of  $[Cr(H_2O)_4Cl(NO_2)]Cl$  is (2010)  
 (a)  $[Cr(H_2O)_4(O_2N)]Cl_2$  (b)  $[Cr(H_2O)_4Cl_2](NO_2)$   
 (c)  $[Cr(H_2O)_4Cl(ONO)]Cl$  (d)  $[Cr(H_2O)_4Cl_2(NO_2)] \cdot H_2O$
42. The correct structure of ethylenediaminetetraacetic acid (EDTA) is (2010)  
 (a) 
$$\begin{array}{c} \text{HOOC} - \text{H}_2\text{C} \\ \text{HOOC} - \text{H}_2\text{C} \end{array} \rangle \text{N} - \text{CH} = \text{CH} - \text{N} \langle \begin{array}{c} \text{CH}_2 - \text{COOH} \\ \text{CH}_2 - \text{COOH} \end{array}$$
  
 (b) 
$$\begin{array}{c} \text{HOOC} \\ \text{HOOC} \end{array} \rangle \text{N} - \text{CH}_2 - \text{CH}_2 - \text{N} \langle \begin{array}{c} \text{COOH} \\ \text{COOH} \end{array}$$
  
 (c) 
$$\begin{array}{c} \text{HOOC} - \text{H}_2\text{C} \\ \text{HOOC} - \text{H}_2\text{C} \end{array} \rangle \text{N} - \text{CH}_2 - \text{CH}_2 - \text{N} \langle \begin{array}{c} \text{CH}_2 - \text{COOH} \\ \text{CH}_2 - \text{COOH} \end{array}$$
  
 (d) 
$$\begin{array}{c} \text{COOH} \\ | \\ \text{CH}_2 \\ | \\ \text{HOOC} - \text{H}_2\text{C} \rangle \text{N} - \text{CH} - \text{CH} - \text{N} \langle \begin{array}{c} \text{H} \\ | \\ \text{CH}_2 - \text{COOH} \end{array} \\ | \\ \text{CH}_2 \\ | \\ \text{HOOC} \end{array}$$
43. The complex showing a spin-only magnetic moment of 2.82 B.M. is: (2010)  
 (a)  $Ni(CO)_4$  (b)  $[NiCl_4]^{2-}$   
 (c)  $Ni(PPh_3)_4$  (d)  $[Ni(CN)_4]^{2-}$
44. Among the following complexes (K–P)  
 $K_3[Fe(CN)_6]$  (K),  $[Co(NH_3)_6]Cl_3$  (L),  $Na_3[Co(oxalate)_3]$  (M), the  
 $[Ni(H_2O)_6]Cl_2$  (N),  $K_2[Pt(CN)_4]$  (O) and  $[Zn(H_2O)_6](NO_3)_2$  (P)  
 the diamagnetic complexes are (2011)  
 (a) K, L, M, N (b) K, M, O, P  
 (c) L, M, O, P (d) L, M, N, O
45. As per IUPAC nomenclature, the name of the complex  $[Co(H_2O)_4(NH_3)_2]Cl_3$  is: (2012)  
 (a) Tetraaquadiaminecobalt (III) chloride  
 (b) Tetraaquadiamminecobalt (III) chloride  
 (c) Diaminetetraaquacobalt (II) chloride  
 (d) Diamminetetraaquacobalt (III) chloride
46. The colour of light absorbed by an aqueous solution of  $CuSO_4$  is: (2012)  
 (a) orange-red (b) blue-green  
 (c) yellow (d) violet
47.  $NiCl_2 \cdot 2P(C_2H_5)_2(C_6H_5)_2$  exhibits temperature dependent magnetic behaviour (paramagnetic/diamagnetic). The coordination geometries of  $Ni^{2+}$  in the paramagnetic and diamagnetic states are respectively (2012)  
 (a) tetrahedral and tetrahedral  
 (b) square planar and square planar  
 (c) tetrahedral and square planar  
 (d) square planar and tetrahedral

48. Consider the following complex ions, P, Q and R.  
 $P = [FeF_6]^{3-}$ ,  $Q = [V(H_2O)_6]^{2+}$  and  $R = [Fe(H_2O)_6]^{2+}$   
 The correct order of the complex ions, according to their spin-only magnetic moment values (in B.M.) is  
 (JEE Adv. 2013)
- (a)  $R < Q < P$  (b)  $Q < R < P$   
 (c)  $R < P < Q$  (d)  $Q < P < R$
49. Among  $[Ni(CO)_4]$ ,  $[NiCl_4]^{2-}$ ,  $[Co(NH_3)_4Cl_2]Cl$ ,  $Na_3[CoF_6]$ ,  $Na_2O_2$  and  $CsO_2$ , the total number of paramagnetic compounds is  
 (JEE Adv. 2016)
- (a) 2 (b) 3  
 (c) 4 (d) 5

### D MCQs with One or More Than One Correct

1. Potassium manganate ( $K_2MnO_4$ ) is formed when  
 (1988 - 1 Mark)
- (a) chlorine is passed into aqueous  $KMnO_4$  solution  
 (b) manganese dioxide is fused with potassium hydroxide in air  
 (c) formaldehyde reacts with potassium permanganate in presence of a strong alkali  
 (d) potassium permanganate reacts with conc. sulphuric acid
2. The aqueous solutions of the following salts will be coloured in the case of  
 (1990 - 1 Mark)
- (a)  $Zn(NO_3)_2$  (b)  $LiNO_3$   
 (c)  $Co(NO_3)_2$  (d)  $CrCl_3$   
 (e) Potash alum
3. Among the following ions which one has the highest paramagnetism?  
 (1993 - 1 Mark)
- (a)  $[Cr(H_2O)_6]^{3+}$  (b)  $[Fe(H_2O)_6]^{2+}$   
 (c)  $[Cu(H_2O)_6]^{2+}$  (d)  $[Zn(H_2O)_6]^{2+}$
4. Which of the following alloys contains(s) Cu and Zn?  
 (1993 - 1 Mark)
- (a) Bronze (b) Brass  
 (c) Gun metal (d) Type metal
5. In nitroprusside ion the iron and NO exist as  $Fe^{II}$  and  $NO^+$  rather than  $Fe^{III}$  and NO. These forms can be differentiated by  
 (1998 - 2 Marks)
- (a) estimating the concentration of iron  
 (b) measuring the concentration of  $CN^-$   
 (c) measuring the solid state magnetic moment  
 (d) thermally decomposing the compound.
6. Addition of high proportions of manganese makes steel useful in making rails of railroads, because manganese  
 (1998 - 2 Marks)
- (a) gives hardness to steel  
 (b) helps the formation of oxides of iron  
 (c) can remove oxygen and sulphur  
 (d) can show highest oxidation state of +7.
7. If the bond length of CO bond in carbon monoxide is  $1.128 \text{ \AA}$ , then what is the value of CO bond length in  $Fe(CO)_5$ ?  
 (2006 - 5M, -1)
- (a)  $1.15 \text{ \AA}$  (b)  $1.128 \text{ \AA}$   
 (c)  $1.13 \text{ \AA}$  (d)  $1.118 \text{ \AA}$
8. The compound(s) that exhibit(s) geometrical isomerism is (are)  
 (2009)
- (a)  $[Pt(en)Cl_2]$  (b)  $[Pt(en)_2]Cl_2$   
 (c)  $[Pt(en)_2Cl_2]Cl_2$  (d)  $[Pt(NH_3)_2Cl_2]$
9. Reduction of the metal centre in aqueous permanganate ion involves  
 (2011)
- (a) 3 electrons in neutral medium  
 (b) 5 electrons in neutral medium  
 (c) 3 electrons in alkaline medium  
 (d) 5 electrons in acidic medium
10. The equilibrium  
 (2011)
- $$2Cu^I \rightleftharpoons Cu^0 + Cu^{II}$$
- in aqueous medium at  $25^\circ C$  shifts towards the left in the presence of
- (a)  $NO_3^-$  (b)  $Cl^-$   
 (c)  $SCN^-$  (d)  $CN^-$
11. For the given aqueous reactions, which of the statement (s) is (are) true?
- excess  $KI + K_3[Fe(CN)_6] \xrightarrow{\text{dilute } H_2SO_4} \text{brownish-yellow solution}$
- ↓  $ZnSO_4$
- white precipitate + brownish-yellow filtrate
- ↓  $Na_2S_2O_3$
- colourless solution
- (a) The first reaction is a redox reaction. (2012)  
 (b) White precipitate is  $Zn_3[Fe(CN)_6]_2$ .  
 (c) Addition of filtrate to starch solution gives blue colour.  
 (d) White precipitate is soluble in NaOH solution.
12. The pair(s) of coordination complexes/ions exhibiting the same kind of isomerism is(are)  
 (JEE Adv. 2013)
- (a)  $[Cr(NH_3)_5Cl]Cl_2$  and  $[Cr(NH_3)_4Cl_2]Cl$   
 (b)  $[Co(NH_3)_4Cl_2]^+$  and  $[Pt(NH_3)_2(H_2O)Cl]^+$   
 (c)  $[CoBr_2Cl_2]^{2-}$  and  $[PtBr_2Cl_2]^{2-}$   
 (d)  $[Pt(NH_3)_3](NO_3)Cl$  and  $[Pt(NH_3)_3Cl]Br$
13. The pair(s) of reagents that yield paramagnetic species is/are  
 (JEE Adv. 2014)
- (a) Na and excess of  $NH_3$   
 (b) K and excess of  $O_2$   
 (c) Cu and dilute  $HNO_3$   
 (d)  $O_2$  and 2-ethylanthraquinol

14. The correct statement(s) about  $\text{Cr}^{2+}$  and  $\text{Mn}^{3+}$  is(are)  
[Atomic numbers of Cr = 24 and Mn = 25] (JEE Adv. 2015)
- $\text{Cr}^{2+}$  is a reducing agent
  - $\text{Mn}^{3+}$  is an oxidizing agent
  - Both  $\text{Cr}^{2+}$  and  $\text{Mn}^{3+}$  exhibit  $d^4$  electronic configuration
  - When  $\text{Cr}^{2+}$  is used as a reducing agent, the chromium ion attains  $d^5$  electronic configuration
15.  $\text{Fe}^{3+}$  is reduced to  $\text{Fe}^{2+}$  by using (JEE Adv. 2015)
- $\text{H}_2\text{O}_2$  in presence of NaOH
  - $\text{Na}_2\text{O}_2$  in water
  - $\text{H}_2\text{O}_2$  in presence of  $\text{H}_2\text{SO}_4$
  - $\text{Na}_2\text{O}_2$  in presence of  $\text{H}_2\text{SO}_4$
- E Subjective Problems**
1. A certain inorganic compound (A) on heating loses its water of crystallisation. On further heating, a blackish brown powder (B) and two oxides of sulphur (C and D) are obtained. The powder (B) on boiling with hydrochloric acid gives a yellow solution (E). When  $\text{H}_2\text{S}$  is passed in (E) a white turbidity (F) and an apple green solution (G) are obtained. The solution (E) on treatment with thiocyanate ions gives a blood red coloured compound (H). Identify compounds from (A) to (H). (1978)
2. A white amorphous powder (A) on heating yields a colourless, non-combustible gas (B) and a solid (C). The latter compound assumes a yellow colour on heating and changes to white on cooling. 'C' dissolves in dilute acid and the resulting solution gives a white precipitate on adding  $\text{K}_4\text{Fe}(\text{CN})_6$  solution. 'A' dissolves in dilute HCl with the evolution of gas, which is identical in all respects with 'B'. The gas 'B' turns lime water milky, but the milkiness disappears with the continuous passage of gas. The solution of 'A', as obtained above, gives a white precipitate (D) on the addition of excess of  $\text{NH}_4\text{OH}$  and passing  $\text{H}_2\text{S}$ . Another portion of the solution gives initially a white precipitate (E) on the addition of sodium hydroxide solution, which dissolves on further addition of the base. Identify the compounds A, B, D, and E. (1979)
3. State with balanced equations, what happens when
- Silver is treated with hot concentrated sulphuric acid.
  - Ammonium dichromate is heated.
  - Hydrogen sulphide is passed through a solution of potassium permanganate acidified with dilute sulphuric acid. (1979)
4. A solution of  $\text{FeCl}_3$  in water gives a brown precipitate on standing. (1980)
5. Complete the following equation (no balancing is needed):  
 $\text{SO}_2 + \text{MnO}_4^- + \dots \longrightarrow \text{SO}_4^{2-} + \text{Mn}^{2+} + \dots$   
(1981 - 1 Mark)
6. State with balanced equations what happens when :
- sulphur dioxide gas is bubbled through an aqueous solution of copper sulphate in presence of potassium thiocyanate. (1982 - 1 Mark)
  - aqueous solution of ferric sulphate and potassium iodide are mixed. (1984 - 2 Marks)
  - aqueous solution of potassium manganate and acid are mixed. (1984 - 2 Marks)
  - aqueous solution of potassium chromate and acid are mixed. (1984 - 2 Marks)
  - potassium permanganate interacts with manganese dioxide in presence of potassium hydroxide; (1985 - 1 Mark)
  - potassium ferrocyanide is heated with concentrated sulphuric acid; (1985 - 1 Mark)
  - Gold is dissolved in *aqua regia*. (1987 - 1 Mark)
  - Write balanced equations for the extraction of silver from silver glance by cyanide process. (1988 - 1 Mark)
  - Silver chloride is treated with aqueous sodium cyanide and the product thus formed is allowed to react with zinc in alkaline medium. (1989 - 1 Mark)
  - Cobalt(II) solution reacts with  $\text{KNO}_2$  in acetic acid medium. (1989 - 1 Mark)
  - Write balanced equations for the extraction of copper from copper pyrites by self-reduction. (1990 - 2 Marks)
  - A mixture of potassium dichromate and sodium chloride is heated with concentrated  $\text{H}_2\text{SO}_4$ . (1990 - 1 Mark)
  - Iron reacts with cold dilute nitric acid. (1990 - 1 Mark)
  - Potassium permanganate is added to a hot solution of manganous sulphate. (1990 - 1 Mark)
  - Copper reacts with  $\text{HNO}_3$  to give NO and  $\text{NO}_2$  in molar ratio of 2 : 1. (1992 - 1 Marks)  
 $\text{Cu} + \text{HNO}_3 \rightarrow \dots + \text{NO} + \text{NO}_2 + \dots$
  - $\text{Na}_2\text{CO}_3$  is added to a solution of copper sulphate. (1992 - 1 Marks)  
 $\text{CuSO}_4 + \text{Na}_2\text{CO}_3 + \text{H}_2\text{O} \rightarrow \dots + \text{Na}_2\text{SO}_4 + \dots$
  - Potassium dichromate and concentrated hydrochloric acid are heated together. (1992 - 1 Mark)
  - $\text{AgBr} + \text{Na}_2\text{S}_2\text{O}_3 \rightarrow \dots + \dots$  (1993 - 1 Mark)
  - $(\text{NH}_4)_2\text{S}_2\text{O}_8 + \text{H}_2\text{O} + \text{MnSO}_4 \rightarrow \dots + \dots + \dots$  (1993 - 1 Mark)
  - $[\text{MnO}_4]^{2-} + \text{H}^+ \longrightarrow \dots + [\text{MnO}_4]^- + \text{H}_2\text{O}$  (1994 - 1 Mark)

- (xxi)  $\text{SO}_2(\text{aq}) + \text{Cr}_2\text{O}_7^{2-} + 2\text{H}^+ \longrightarrow \dots + \dots + \dots$   
(1994 - 1 Mark)
- (xxii) Write a balanced equation for the reaction of argentite with KCN and name the products in solution.  
(1996 - 1 Mark)
- (xxiii) Write balanced equations for the reaction of zinc with dilute nitric acid.  
(1997 - 1 Mark)
7. Give balanced equations for extraction of silver from its sulphide ore  
(1982 - 2 Marks)
8. Give reasons for the following :
- (i) Silver bromide is used in photography.  
(1983 - 1 Mark)
- (ii) Most transition metal compounds are coloured.  
(1986 - 1 Mark)
- (iii) Zinc and not copper is used for the recovery of metallic silver from complex  $[\text{Ag}(\text{CN})_2]^-$ . Explain.  
(1987 - 1 Mark)
- (iv) The colour of mercurous chloride,  $\text{Hg}_2\text{Cl}_2$ , changes from white to black when treated with ammonia.  
(1988 - 1 Mark)
- (v) The species  $[\text{CuCl}_4]^{2-}$  exists while  $[\text{CuI}_4]^{2-}$  does not.  
(1992 - 1 Mark)
- (vi)  $\text{CrO}_3$  is an acid anhydride.  
(1999 - 2 Marks)
9. State the conditions under which the following preparation is carried out.  
Potassium permanganate from manganese hydroxide.  
Give the necessary equations which need not be balanced.  
(1983 - 1 Mark)
10. What happens when :
- (i) aqueous ammonia is added dropwise to a solution of copper sulphate till it is in excess. (1985 - 1 Mark)
- (ii)  $\text{CrCl}_3$  solution is treated with sodium hydroxide and then with hydrogen peroxide. (1985 - 1 Mark)
11. Mention the products formed when zinc oxide is treated with excess of sodium hydroxide solution. (1986 - 1 Mark)
12. What is the actual reducing agent of haematite in blast furnace?  
(1987 - 1 Mark)
13. The acidic, aqueous solution of ferrous ion forms a brown complex in the presence of  $\text{NO}_3^-$ , by the following two steps. Complete and balance the equations : (1993 - 2 Marks)
- $[\text{Fe}(\text{H}_2\text{O})_6]^{2+} + \text{NO}_3^- + \text{H}^+ \rightarrow \dots + [\text{Fe}(\text{H}_2\text{O})_6]^{3+} + \text{H}_2\text{O}$
- $[\text{Fe}(\text{H}_2\text{O})_6]^{2+} + \dots \rightarrow \dots + \text{H}_2\text{O}$
14. Identify the complexes which are expected to be coloured. Explain (1994 - 2 Marks)
- (i)  $[\text{Ti}(\text{NO}_3)_4]$  (ii)  $[\text{Cu}(\text{NCCH}_3)_4]^+ \text{BF}_4^-$   
(iii)  $[\text{Cr}(\text{NH}_3)_6]^{3+} 3\text{Cl}^-$  (iv)  $\text{K}_3[\text{VF}_6]$
15. Write down the IUPAC names of the following compounds :
- (i)  $[\text{Co}(\text{NH}_3)_5\text{ONO}]\text{Cl}_2$  (1995 - 1 Mark)
- (ii)  $\text{K}_3[\text{Cr}(\text{CN})_6]$  (1995 - 1 Mark)
- (iii)  $[\text{Cr}(\text{NH}_3)_5\text{CO}_3]\text{Cl}$  (1996 - 1 Mark)
16. Compare qualitatively the first and second ionisation potentials of copper and zinc. Explain the observation.  
(1996 - 2 Marks)
17. Write the formulae of the following complexes :
- (i) Pentamminechlorocobalt(III) (1997 - 1 Mark)
- (ii) Lithium tetrahydroaluminate(III). (1997 - 1 Mark)
18. When the ore haematite is burnt in air with coke around  $2000^\circ\text{C}$  along with lime, the process not only produces steel but also produces a silicate slag that is useful in making building materials such as cement. Discuss the same and show through balanced chemical equations.  
(1998 - 4 Marks)
19. Work out the following using chemical equations (1998 - 2 Marks)
- In moist air copper corrodes to produce a green layer on the surface.
20. A, B, and C are three complexes of chromium (III) with the empirical formula  $\text{H}_{12}\text{O}_6\text{Cl}_3\text{Cr}$ . All the three complexes have water and chloride ion as ligands. Complex A does not react with concentrated  $\text{H}_2\text{SO}_4$ , whereas complexes B and C lose 6.75% and 13.5% of their original mass, respectively, on treatment with concentrated  $\text{H}_2\text{SO}_4$ . Identify A, B and C.  
(1999 - 6 Marks)
21. Write the chemical reaction associated with the 'brown ring test'.  
(2000 - 2 Marks)
22. Draw the structures of  $[\text{Co}(\text{NH}_3)_6]^{3+}$ ,  $[\text{Ni}(\text{CN})_4]^{2-}$  and  $[\text{Ni}(\text{CO})_4]$ . Write the hybridisation of atomic orbitals of the transition metal in each case. (2000 - 4 Marks)
23. (i) Write the chemical reactions involved in the extraction of metallic silver from argentite.  
(ii) Write the balanced chemical equation for developing photographic films. (2000 - 4 Marks)
24. A metal complex having composition  $\text{Cr}(\text{NH}_3)_4\text{Cl}_2\text{Br}$  has been isolated in two forms (A) and (B). The form (A) reacts with  $\text{AgNO}_3$  to give a white precipitate readily soluble in dilute aqueous ammonia, whereas (B) gives a pale yellow precipitate soluble in concentrated ammonia. Write the

## The d- and f-Block Elements and Co-ordination Compounds

formula of (A) and (B) and state the hybridization of chromium in each. Calculate their magnetic moments (spin-only value). (2001 - 5 Marks)

25. Deduce the structure of  $[\text{NiCl}_4]^{2-}$  and  $[\text{Ni}(\text{CN})_4]^{2-}$  considering the hybridization of the metal ion. Calculate the magnetic moment (spin only) of the species. (2002 - 5 Marks)
26. Write the IUPAC nomenclature of the given complex along with its hybridisation and structure.  
 $\text{K}_2[\text{Cr}(\text{NO})(\text{NH}_3)(\text{CN})_4]$ ,  $\mu = 1.73$  BM (2003 - 4 Marks)
27. Nickel chloride, when treated with dimethylglyoxime in presence of ammonium hydroxide, a bright red precipitate is obtained. Answer the following. (2004 - 4 Marks)
- Draw the structure of the complex showing H-bonds
  - Give oxidation state of nickel and its hybridisation
  - Predict the magnetic behaviour of the complex
28. Some reactions of two ores,  $\text{A}_1$  and  $\text{A}_2$  of the metal M are given below. (2004 - 4 Marks)

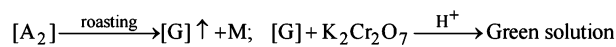
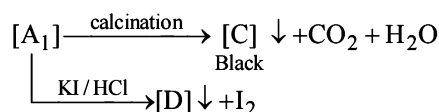

Identify  $\text{A}_1$ ,  $\text{A}_2$ , M, C, D, and G and explain using the required chemical reactions.



What are (A) and (B)? Give IUPAC name of (A). Find the spin only magnetic moment of (B). (2005 - 4 Marks)

30. Write the chemical reaction involved in developing of a black and white photographic film. An aqueous  $\text{Na}_2\text{S}_2\text{O}_3$  solution is acidified to give a milky white turbidity. Identify the product and write the balanced half chemical reaction for it. (2005 - 4 Marks)

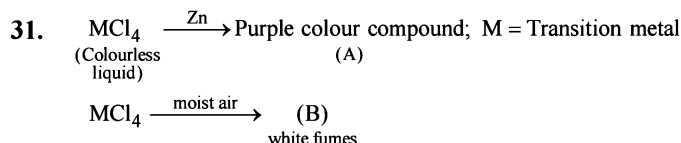

Identify (A), (B) and  $\text{MCl}_4$ . Also explain colour difference between  $\text{MCl}_4$  and (A). (2005 - 4 Marks)

## F Match the Following

**DIRECTIONS (Q. No. 1 and 2):** Each question contains statements given in two columns, which have to be matched. The statements in Column-I are labelled A, B, C and D, while the statements in Column-II are labelled p, q, r, s and t. Any given statement in Column-I can have correct matching with ONE OR MORE statement(s) in Column-II. The appropriate bubbles corresponding to the answers to these questions have to be darkened as illustrated in the following example:

If the correct matches are A-p, s and t; B-q and r; C-p and q; and D-s then the correct darkening of bubbles will look like the given.

	p	q	r	s	t
A	<input checked="" type="checkbox"/>	<input checked="" type="checkbox"/>	<input type="checkbox"/>	<input checked="" type="checkbox"/>	<input checked="" type="checkbox"/>
B	<input type="checkbox"/>	<input checked="" type="checkbox"/>	<input checked="" type="checkbox"/>	<input type="checkbox"/>	<input type="checkbox"/>
C	<input checked="" type="checkbox"/>	<input checked="" type="checkbox"/>	<input type="checkbox"/>	<input type="checkbox"/>	<input type="checkbox"/>
D	<input type="checkbox"/>	<input type="checkbox"/>	<input type="checkbox"/>	<input checked="" type="checkbox"/>	<input type="checkbox"/>

1. Match the complexes in Column I with their properties listed in Column II. (2007)

### Column I

- (A)  $[\text{Co}(\text{NH}_3)_4(\text{H}_2\text{O})_2]\text{Cl}_2$   
 (B)  $[\text{Pt}(\text{NH}_3)_2\text{Cl}_2]$   
 (C)  $[\text{Co}(\text{H}_2\text{O})_5\text{Cl}]\text{Cl}$   
 (D)  $[\text{Ni}(\text{H}_2\text{O})_6]\text{Cl}_2$

### Column II

- (p) geometrical isomers  
 (q) paramagnetic  
 (r) diamagnetic  
 (s) metal ion with +2 oxidation state

2. Match each of the reactions given in Column I with the corresponding product(s) given in Column II. (2009)

### Column I

- (A)  $\text{Cu} + \text{dil HNO}_3$   
 (B)  $\text{Cu} + \text{conc HNO}_3$   
 (C)  $\text{Zn} + \text{dil HNO}_3$   
 (D)  $\text{Zn} + \text{conc HNO}_3$

### Column II

- (p) NO  
 (q)  $\text{NO}_2$   
 (r)  $\text{N}_2\text{O}$   
 (s)  $\text{Cu}(\text{NO}_3)_2$   
 (t)  $\text{Zn}(\text{NO}_3)_2$

**DIRECTIONS (Q. No. 3) :** Following question has matching lists. The codes for the list have choices (a), (b), (c) and (d) out of which **ONLY ONE** is correct.

3. Match each coordination compound in List-I with an appropriate pair of characteristics from List- II and select the correct answer using the code given below the lists.

{en = H<sub>2</sub>NCH<sub>2</sub>CH<sub>2</sub>NH<sub>2</sub>; atomic numbers : Ti = 22; Cr = 24; Co = 27; Pt = 78}

(JEE Adv. 2014)

**List-I**

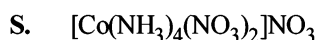
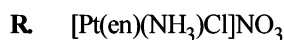
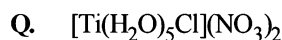

**List-II**

1. Paramagnetic and exhibits ionisation isomerism
2. Diamagnetic and exhibits *cis-trans* isomerism
3. Paramagnetic and exhibits *cis-trans* isomerism
4. Diamagnetic and exhibits ionisation isomerism

**Code:**

	P	Q	R	S
(a)	4	2	3	1
(b)	3	1	4	2
(c)	2	1	3	4
(d)	1	3	4	2

## G Comprehension Based Questions

### PASSAGE 1

The coordination number of Ni<sup>2+</sup> is 4.

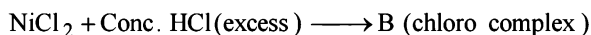
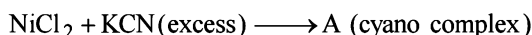

1. The IUPAC name of A and B are (2006 - 5M, -2)
  - (a) Potassium tetracyanonickelate (II), potassium tetrachloronickelate (II)
  - (b) Tetracyanopotassiumnickelate (II), tetrachloropotassiumnickelate (II)
  - (c) Tetracyanonickel (II), tetrachloronickel (II)
  - (d) Potassium tetracyanonickel (II), potassium tetrachloronickel (II)
2. Predict the magnetic nature of A and B (2006 - 5M, -2)
  - (a) Both are diamagnetic
  - (b) A is diamagnetic and B is paramagnetic with one unpaired electron
  - (c) A is diamagnetic and B is paramagnetic with two unpaired electrons
  - (d) Both are paramagnetic
3. The hybridization of A and B are (2006 - 5M, -2)
  - (a) *dsp*<sup>2</sup>, *sp*<sup>3</sup>
  - (b) *sp*<sup>3</sup>, *sp*<sup>3</sup>
  - (c) *dsp*<sup>2</sup>, *dsp*<sup>2</sup>
  - (d) *sp*<sup>3</sup>*d*<sup>2</sup>, *d*<sup>2</sup>*sp*<sup>3</sup>

### PASSAGE 2

Copper is the most noble of the first row transition metals and occurs in small deposits in several countries. Ores of copper include chalcantite (CuSO<sub>4</sub>·5H<sub>2</sub>O), atacamite (Cu<sub>2</sub>Cl(OH)<sub>3</sub>), cuprite (Cu<sub>2</sub>O), copper glance (Cu<sub>2</sub>S) and malachite (Cu<sub>2</sub>(OH)<sub>2</sub>CO<sub>3</sub>). However, 80% of the world copper production

comes from the ore chalcopyrite (CuFeS<sub>2</sub>). The extraction of copper from chalcopyrite involves partial roasting, removal of iron and self-reduction. (2010)

4. Partial roasting of chalcopyrite produces
  - (a) Cu<sub>2</sub>S and FeO
  - (b) Cu<sub>2</sub>O and FeO
  - (c) CuS and Fe<sub>2</sub>O<sub>3</sub>
  - (d) Cu<sub>2</sub>O and Fe<sub>2</sub>O<sub>3</sub>
5. Iron is removed from chalcopyrite as
  - (a) FeO
  - (b) FeS
  - (c) Fe<sub>2</sub>O<sub>3</sub>
  - (d) FeSiO<sub>3</sub>
6. In self-reduction, the reducing species is
  - (a) S
  - (b) O<sup>2-</sup>
  - (c) S<sup>2-</sup>
  - (d) SO<sub>2</sub>

### PASSAGE 3

When a metal rod **M** is dipped into an aqueous colourless concentrated solution of compound **N**, the solution turns light blue. Addition of aqueous NaCl to the blue solution gives a white precipitate **O**. Addition of aqueous NH<sub>3</sub> dissolves **O** and gives an intense blue solution. (2011)

7. The metal rod **M** is
  - (a) Fe
  - (b) Cu
  - (c) Ni
  - (d) CO
8. The compound **N** is
  - (a) AgNO<sub>3</sub>
  - (b) Zn(NO<sub>3</sub>)<sub>2</sub>
  - (c) Al(NO<sub>3</sub>)<sub>3</sub>
  - (d) Pb(NO<sub>3</sub>)<sub>2</sub>
9. The final solution contains
  - (a) [Pb(NH<sub>3</sub>)<sub>4</sub>]<sup>2+</sup> and [CoCl<sub>4</sub>]<sup>2-</sup>
  - (b) [Al(NH<sub>3</sub>)<sub>4</sub>]<sup>3+</sup> and [Cu(NH<sub>3</sub>)<sub>4</sub>]<sup>2+</sup>
  - (c) [Ag(NH<sub>3</sub>)<sub>2</sub>]<sup>+</sup> and [Cu(NH<sub>3</sub>)<sub>4</sub>]<sup>2+</sup>
  - (d) [Ag(NH<sub>3</sub>)<sub>2</sub>]<sup>+</sup> and [Ni(NH<sub>3</sub>)<sub>6</sub>]<sup>2+</sup>

**H Assertion & Reason Type Questions**

Read the following statement-1 (Assertion/Statement) and Statement -2 (Reason/Explanation) and answer as per the options given below :

- (a) Statement-1 is True, Statement-2 is True; Statement-2 is a correct explanation for Statement-1.  
 (b) Statement-1 is True, Statement-2 is True; Statement-2 is NOT a correct explanation for Statement-1  
 (c) Statement-1 is True, Statement-2 is False  
 (d) Statement-1 is False, Statement-2 is True
- Statement-1** : To a solution of potassium chromate if a strong acid is added it changes its colour from yellow to orange.  
**Statement-2** : The colour change is due to the oxidation of potassium chromate. (1988 - 2 Marks)
  - Statement-1** :  $\text{Zn}^{2+}$  is diamagnetic.  
**Statement-2** : Two electrons are lost from 4s orbital to form  $\text{Zn}^{2+}$ . (1998 - 2 Marks)
  - Statement-1** : The geometrical isomers of the complex  $[\text{M}(\text{NH}_3)_4\text{Cl}_2]$  are optically inactive.  
and  
**Statement-2** : Both geometrical isomers of the complex  $[\text{M}(\text{NH}_3)_4\text{Cl}_2]$  possess axis of symmetry. (2008 - 2 Marks)
  - Statement-1** :  $[\text{Fe}(\text{H}_2\text{O})_5\text{NO}]\text{SO}_4$  is paramagnetic.  
and  
**Statement-2** : The Fe in  $[\text{Fe}(\text{H}_2\text{O})_5\text{NO}]\text{SO}_4$  has three unpaired electrons. (2008)

**I Integer Value Correct Type**

- The number of water molecule(s) directly bonded to the metal centre in  $\text{CuSO}_4 \cdot 5\text{H}_2\text{O}$  is (2009 - 4 Marks)
- The oxidation number of Mn in the product of alkaline oxidative fusion of  $\text{MnO}_2$  is (2009 - 4 Marks)

- Total number of geometrical isomers for the complex  $[\text{RhCl}(\text{CO})(\text{PPh}_3)(\text{NH}_3)]$  is (2010)
- The volume (in mL) of 0.1 M  $\text{AgNO}_3$  required for complete precipitation of chloride ions present in 30 mL of 0.01 M solution of  $[\text{Cr}(\text{H}_2\text{O})_5\text{Cl}]\text{Cl}_2$ , as silver chloride is close to (2011)
- $\text{EDTA}^{4-}$  is ethylenediaminetetraacetate ion. The total number of N—Co—O bond angles in  $[\text{Co}(\text{EDTA})]^{1-}$  complex ion is (JEE Adv. 2013)
- Consider the following list of reagents: (JEE Adv. 2014)  
Acidified  $\text{K}_2\text{Cr}_2\text{O}_7$ , alkaline  $\text{KMnO}_4$ ,  $\text{CuSO}_4$ ,  $\text{H}_2\text{O}_2$ ,  $\text{Cl}_2$ ,  $\text{O}_3$ ,  $\text{FeCl}_3$ ,  $\text{HNO}_3$  and  $\text{Na}_2\text{S}_2\text{O}_3$ .  
The total number of reagents that can oxidise aqueous iodide to iodine is
- In the complex acetyl bromidodicarbonylbis (triethylphosphine) iron (II), the number of Fe—C bond(s) is (JEE Adv. 2015)
- Among the complex ions,  $[\text{Co}(\text{NH}_2\text{—CH}_2\text{—CH}_2\text{—NH}_2)_2\text{Cl}_2]^+$ ,  $[\text{CrCl}_2(\text{C}_2\text{O}_4)_2]^{3-}$ ,  $[\text{Fe}(\text{H}_2\text{O})_4(\text{OH})_2]^+$ ,  $[\text{Fe}(\text{NH}_3)_2(\text{CN})_4]^-$ ,  $[\text{Co}(\text{NH}_2\text{—CH}_2\text{—CH}_2\text{—NH}_2)_2(\text{NH}_3)\text{Cl}]^{2+}$  and  $[\text{Co}(\text{NH}_3)_4(\text{H}_2\text{O})\text{Cl}]^{2+}$ , the number of complex ion(s) that show(s) *cis-trans* isomerism is (JEE Adv. 2015)
- For the octahedral complexes of  $\text{Fe}^{3+}$  in  $\text{SCN}^-$  (thiocyanato-S) and in  $\text{CN}^-$  ligand environments, the difference between the spin-only magnetic moments in Bohr magnetons (when approximated to the nearest integer) is [Atomic number of Fe = 26] (JEE Adv. 2015)
- In neutral or faintly alkaline solution, 8 moles of permanganate anion quantitatively oxidize thiosulphate anions to produce X moles of a sulphur containing product. The magnitude of X is (JEE Adv. 2016)
- The number of geometric isomers possible for the complex  $[\text{CoL}_2\text{Cl}_2]$  (L =  $\text{H}_2\text{NCH}_2\text{CH}_2\text{O}^-$ ) is (JEE Adv. 2016)

**Section-B JEE Main / AIEEE**

- A square planar complex is formed by hybridisation of which atomic orbitals? [2002]  
 (a)  $s, p_x, p_y, d_{yz}$  (b)  $s, p_x, p_y, d_{x^2-y^2}$   
 (c)  $s, p_x, p_y, d_{z^2}$  (d)  $s, p_y, p_z, d_{xy}$
- The type of isomerism present in nitropentamine chromium (III) chloride is [2002]  
 (a) optical (b) linkage  
 (c) ionization (d) polymerisation.
- $\text{CH}_3\text{—Mg—Br}$  is an organo metallic compound due to [2002]  
 (a) Mg—Br bond (b) C—Mg bond  
 (c) C—Br bond (d) C—H bond.
- Most common oxidation states of Ce (cerium) are [2002]  
 (a) +2, +3 (b) +2, +4  
 (c) +3, +4 (d) +3, +5.
- Arrange  $\text{Ce}^{+3}$ ,  $\text{La}^{+3}$ ,  $\text{Pm}^{+3}$  and  $\text{Yb}^{+3}$  in increasing order of their ionic radii. [2002]  
 (a)  $\text{Yb}^{+3} < \text{Pm}^{+3} < \text{Ce}^{+3} < \text{La}^{+3}$   
 (b)  $\text{Ce}^{+3} < \text{Yb}^{+3} < \text{Pm}^{+3} < \text{La}^{+3}$   
 (c)  $\text{Yb}^{+3} < \text{Pm}^{+3} < \text{La}^{+3} < \text{Ce}^{+3}$   
 (d)  $\text{Pm}^{+3} < \text{La}^{+3} < \text{Ce}^{+3} < \text{Yb}^{+3}$ .
- Which of the following ions has the maximum magnetic moment? [2002]  
 (a)  $\text{Mn}^{+2}$  (b)  $\text{Fe}^{+2}$   
 (c)  $\text{Ti}^{+2}$  (d)  $\text{Cr}^{+2}$ .
- The most stable ion is [2002]  
 (a)  $[\text{Fe}(\text{OH})_3]^{3-}$  (b)  $[\text{Fe}(\text{Cl})_6]^{3-}$   
 (c)  $[\text{Fe}(\text{CN})_6]^{3-}$  (d)  $[\text{Fe}(\text{H}_2\text{O})_6]^{3+}$ .

8. When  $\text{KMnO}_4$  acts as an oxidising agent and ultimately forms  $[\text{MnO}_4]^{2-}$ ,  $\text{MnO}_2$ ,  $\text{Mn}_2\text{O}_3$ ,  $\text{Mn}^{+2}$  then the number of electrons transferred in each case respectively is  
 (a) 4, 3, 1, 5 (b) 1, 5, 3, 7 [2002]  
 (c) 1, 3, 4, 5 (d) 3, 5, 7, 1.
9. The radius of  $\text{La}^{3+}$  (Atomic number of La = 57) is 1.06 Å. Which one of the following given values will be closest to the radius of  $\text{Lu}^{3+}$  (Atomic number of Lu = 71)?  
 (a) 1.40 Å (b) 1.06 Å [2003]  
 (c) 0.85 Å (d) 1.60 Å
10. Ammonia forms the complex ion  $[\text{Cu}(\text{NH}_3)_4]^{2+}$  with copper ions in alkaline solutions but not in acidic solutions. What is the reason for it? [2003]  
 (a) In acidic solutions protons coordinate with ammonia molecules forming  $\text{NH}_4^+$  ions and  $\text{NH}_3$  molecules are not available  
 (b) In alkaline solutions insoluble  $\text{Cu}(\text{OH})_2$  is precipitated which is soluble in excess of any alkali  
 (c) Copper hydroxide is an amphoteric substance  
 (d) In acidic solutions hydration protects copper ions
11. One mole of the complex compound  $\text{Co}(\text{NH}_3)_5\text{Cl}_3$ , gives 3 moles of ions on dissolution in water. One mole of the same complex reacts with two moles of  $\text{AgNO}_3$  solution to yield two moles of  $\text{AgCl}$  (s). The structure of the complex is  
 (a)  $[\text{Co}(\text{NH}_3)_3\text{Cl}_3] \cdot 2 \text{NH}_3$  [2003]  
 (b)  $[\text{Co}(\text{NH}_3)_4\text{Cl}_2] \text{Cl} \cdot \text{NH}_3$   
 (c)  $[\text{Co}(\text{NH}_3)_4\text{Cl}] \text{Cl}_2 \cdot \text{NH}_3$   
 (d)  $[\text{Co}(\text{NH}_3)_5\text{Cl}] \text{Cl}_2$
12. In the coordination compound,  $\text{K}_4[\text{Ni}(\text{CN})_4]$ , the oxidation state of nickel is [2003]  
 (a) 0 (b) +1  
 (c) +2 (d) -1
13. A red solid is insoluble in water. However it becomes soluble if some KI is added to water. Heating the red solid in a test tube results in liberation of some violet coloured fumes and droplets of a metal appear on the cooler parts of the test tube. The red solid is [2003]  
 (a)  $\text{HgI}_2$  (b)  $\text{HgO}$   
 (c)  $\text{Pb}_3\text{O}_4$  (d)  $(\text{NH}_4)_2\text{Cr}_2\text{O}_7$
14. A reduction in atomic size with increase in atomic number is a characteristic of elements of [2003]  
 (a) d-block (b) f-block  
 (c) radioactive series (d) high atomic masses
15. What would happen when a solution of potassium chromate is treated with an excess of dilute nitric acid? [2003]  
 (a)  $\text{Cr}_2\text{O}_7^{2-}$  and  $\text{H}_2\text{O}$  are formed  
 (b)  $\text{CrO}_4^{2-}$  is reduced to +3 state of Cr  
 (c)  $\text{CrO}_4^{2-}$  is oxidized to +7 state of Cr  
 (d)  $\text{Cr}^{3+}$  and  $\text{Cr}_2\text{O}_7^{2-}$  are formed
16. Which one of the following nitrates will leave behind a metal on strong heating? [2003]  
 (a) Copper nitrate (b) Manganese nitrate  
 (c) Silver nitrate (d) Ferric nitrate
17. Of the following outer electronic configurations of atoms, the highest oxidation state is achieved by which one of them? [2004]  
 (a)  $(n-1)d^3 ns^2$  (b)  $(n-1)d^5 ns^1$   
 (c)  $(n-1)d^8 ns^2$  (d)  $(n-1)d^5 ns^2$
18. The soldiers of Napoleon army while at Alps during freezing winter suffered a serious problem as regards to the tin buttons of their uniforms. White metallic tin buttons got converted to grey powder. This transformation is related to [2004]  
 (a) a change in the partial pressure of oxygen in the air  
 (b) a change in the crystalline structure of tin  
 (c) an interaction with nitrogen of the air at very low temperature  
 (d) an interaction with water vapour contained in the humid air
19. Among the properties (a) reducing (b) oxidising (c) complexing, the set of properties shown by  $\text{CN}^-$  ion towards metal species is [2004]  
 (a) c, a (b) b, c  
 (c) a, b (d) a, b, c
20. The coordination number of a central metal atom in a complex is determined by [2004]  
 (a) the number of ligands around a metal ion bonded by sigma and pi-bonds both  
 (b) the number of ligands around a metal ion bonded by pi-bonds  
 (c) the number of ligands around a metal ion bonded by sigma bonds  
 (d) the number of only anionic ligands bonded to the metal ion.
21. Which one of the following complexes is an outer orbital complex? [2004]  
 (a)  $[\text{Co}(\text{NH}_3)_6]^{3+}$  (b)  $[\text{Mn}(\text{CN})_6]^{4-}$   
 (c)  $[\text{Fe}(\text{CN})_6]^{4-}$  (d)  $[\text{Ni}(\text{NH}_3)_6]^{2+}$   
 (Atomic nos. : Mn = 25; Fe = 26; Co = 27, Ni = 28)
22. Coordination compounds have great importance in biological systems. In this context which of the following statements is **incorrect**? [2004]  
 (a) Cyanocobalamin is  $\text{B}_{12}$  and contains cobalt  
 (b) Haemoglobin is the red pigment of blood and contains irons  
 (c) Chlorophylls are green pigments in plants and contain calcium  
 (d) Carboxypeptidase - A is an exzyme and contains zinc.



23. Cerium ( $Z = 58$ ) is an important member of the lanthanoids. Which of the following statements about cerium is **incorrect**? [2004]
- The +4 oxidation state of cerium is not known in solutions
  - The +3 oxidation state of cerium is more stable than the +4 oxidation state
  - The common oxidation states of cerium are +3 and +4
  - Cerium (IV) acts as an oxidizing agent
24. Which one of the following has largest number of isomers?
- $[\text{Ir}(\text{PR}_3)_2\text{H}(\text{CO})]^{2+}$  [2004]
  - $[\text{Co}(\text{NH}_3)_5\text{Cl}]^{2+}$
  - $[\text{Ru}(\text{NH}_3)_4\text{Cl}_2]^+$
  - $[\text{Co}(\text{en})_2\text{Cl}_2]^+$  (R = alkyl group, en = ethylenediamine)
25. The correct order of magnetic moments (spin only values in B.M.) among is [2004]
- $[\text{Fe}(\text{CN})_6]^{4-} > [\text{MnCl}_4]^{2-} > [\text{CoCl}_4]^{2-}$
  - $[\text{MnCl}_4]^{2-} > [\text{Fe}(\text{CN})_6]^{4-} > [\text{CoCl}_4]^{2-}$
  - $[\text{MnCl}_4]^{2-} > [\text{CoCl}_4]^{2-} > [\text{Fe}(\text{CN})_6]^{4-}$
  - $[\text{Fe}(\text{CN})_6]^{4-} > [\text{CoCl}_4]^{2-} > [\text{MnCl}_4]^{2-}$   
(Atomic nos. : Mn = 25, Fe = 26, Co = 27)
26. The oxidation state Cr in  $[\text{Cr}(\text{NH}_3)_4\text{Cl}_2]^+$  is
- 0
  - +1
  - +2
  - +3
27. Heating mixture of  $\text{Cu}_2\text{O}$  and  $\text{Cu}_2\text{S}$  will give [2005]
- $\text{Cu}_2\text{SO}_3$
  - $\text{CuO} + \text{CuS}$
  - $\text{Cu} + \text{SO}_3$
  - $\text{Cu} + \text{SO}_2$
28. The oxidation state of chromium in the final product formed by the reaction between KI and acidified potassium dichromate solution is: [2005]
- +3
  - +2
  - +6
  - +4
29. Calomel ( $\text{Hg}_2\text{Cl}_2$ ) on reaction with ammonium hydroxide gives [2005]
- $\text{HgO}$
  - $\text{Hg}_2\text{O}$
  - $\text{NH}_2 - \text{Hg} - \text{Hg} - \text{Cl}$
  - $\text{HgNH}_2\text{Cl}$
30. The lanthanide contraction is responsible for the fact that
- Zr and Zn have the same oxidation state [2005]
  - Zr and Hf have about the same radius
  - Zr and Nb have similar oxidation state
  - Zr and Y have about the same radius
31. The IUPAC name of the coordination compound  $\text{K}_3[\text{Fe}(\text{CN})_6]$  is [2005]
- Tripotassium hexacyanoiron (II)
  - Potassium hexacyanoiron (II)
  - Potassium hexacyanoferrate (III)
  - Potassium hexacyanoferrate (II)
32. Which of the following compounds shows optical isomerism? [2005]
- $[\text{Co}(\text{CN})_6]^{3-}$
  - $[\text{Cr}(\text{C}_2\text{O}_4)_3]^{3-}$
  - $[\text{ZnCl}_4]^{2-}$
  - $[\text{Cu}(\text{NH}_3)_4]^{2+}$
33. Which one of the following cyano complexes would exhibit the lowest value of paramagnetic behaviour? [2005]
- $[\text{Co}(\text{CN})_6]^{3-}$
  - $[\text{Fe}(\text{CN})_6]^{3-}$
  - $[\text{Mn}(\text{CN})_6]^{3-}$
  - $[\text{Cr}(\text{CN})_6]^{3-}$
- (At. Nos : Cr = 24, Mn = 25, Fe = 26, Co = 27)
34. The value of the 'spin only' magnetic moment for one of the following configurations is 2.84 BM. The correct one is
- $d^5$  (in strong ligand field) [2005]
  - $d^3$  (in weak as well as in strong fields)
  - $d^4$  (in weak ligand fields)
  - $d^4$  (in strong ligand fields)
35. Which of the following factors may be regarded as the main cause of lanthanide contraction? [2005]
- Greater shielding of 5d electrons by 4f electrons
  - Poorer shielding of 5d electrons by 4f electrons
  - Effective shielding of one of 4f electrons by another in the subshell
  - Poor shielding of one of 4f electron by another in the subshell
36. The IUPAC name for the complex  $[\text{Co}(\text{NO}_2)(\text{NH}_3)_5]\text{Cl}_2$  is : [2006]
- pentaammine nitrito-N-cobalt(II) chloride
  - pentaammine nitrito-N-cobalt(III) chloride
  - nitrito-N-pentaamminecobalt(III) chloride
  - nitrito-N-pentaamminecobalt(II) chloride
37. A metal, M forms chlorides in its +2 and +4 oxidation states. Which of the following statements about these chlorides is correct? [2006]
- $\text{MCl}_2$  is more ionic than  $\text{MCl}_4$
  - $\text{MCl}_2$  is more easily hydrolysed than  $\text{MCl}_4$
  - $\text{MCl}_2$  is more volatile than  $\text{MCl}_4$
  - $\text{MCl}_2$  is more soluble in anhydrous ethanol than  $\text{MCl}_4$

38. Nickel ( $Z = 28$ ) combines with a uninegative monodentate ligand  $X^-$  to form a paramagnetic complex  $[\text{NiX}_4]^{2-}$ . The number of unpaired electron(s) in the nickel and geometry of this complex ion are, respectively: [2006]  
 (a) one, square planar (b) two, square planar  
 (c) one, tetrahedral (d) two, tetrahedral
39. In  $\text{Fe}(\text{CO})_5$ , the Fe – C bond possesses [2006]  
 (a) ionic character (b)  $\sigma$ -character only  
 (c)  $\pi$ -character (d) both  $\sigma$  and  $\pi$  characters
40. Lanthanoid contraction is caused due to [2006]  
 (a) the same effective nuclear charge from Ce to Lu  
 (b) the imperfect shielding on outer electrons by 4f electrons from the nuclear charge  
 (c) the appreciable shielding on outer electrons by 4f electrons from the nuclear charge  
 (d) the appreciable shielding on outer electrons by 5d electrons from the nuclear charge
41. How many EDTA (ethylenediaminetetraacetic acid) molecules are required to make an octahedral complex with a  $\text{Ca}^{2+}$  ion? [2006]  
 (a) One (b) Two  
 (c) Six (d) Three
42. The "spin-only" magnetic moment [in units of Bohr magneton, ( $\mu_B$ )] of  $\text{Ni}^{2+}$  in aqueous solution would be (At. No. Ni = 28) [2006]  
 (a) 6 (b) 1.73  
 (c) 2.84 (d) 4.90
43. The stability of dihalides of Si, Ge, Sn and Pb increases steadily in the sequence [2007]  
 (a)  $\text{PbX}_2 \ll \text{SnX}_2 \ll \text{GeX}_2 \ll \text{SiX}_2$   
 (b)  $\text{GeX}_2 \ll \text{SiX}_2 \ll \text{SnX}_2 \ll \text{PbX}_2$   
 (c)  $\text{SiX}_2 \ll \text{GeX}_2 \ll \text{PbX}_2 \ll \text{SnX}_2$   
 (d)  $\text{SiX}_2 \ll \text{GeX}_2 \ll \text{SnX}_2 \ll \text{PbX}_2$
44. Identify the incorrect statement among the following:  
 (a) 4f and 5f orbitals are equally shielded. [2007]  
 (b) d-Block elements show irregular and erratic chemical properties among themselves.  
 (c) La and Lu have partially filled d-orbitals and no other partially filled orbitals.  
 (d) The chemistry of various lanthanoids is very similar.
45. Which of the following has a square planar geometry?  
 (a)  $[\text{PtCl}_4]^{2-}$  (b)  $[\text{CoCl}_4]^{2-}$  [2007]  
 (c)  $[\text{FeCl}_4]^{2-}$  (d)  $[\text{NiCl}_4]^{2-}$   
 (At. nos.: Fe = 26, Co = 27, Ni = 28, Pt = 78)
46. The actinoids exhibit more number of oxidation states in general than the lanthanoids. This is because [2007]  
 (a) the 5f orbitals extend further from the nucleus than the 4f orbitals  
 (b) the 5f orbitals are more buried than the 4f orbitals  
 (c) there is a similarity between 4f and 5f orbitals in their angular part of the wave function  
 (d) the actinoids are more reactive than the lanthanoids.
47. The coordination number and the oxidation state of the element 'E' in the complex  $[\text{E}(\text{en})_2(\text{C}_2\text{O}_4)]\text{NO}_2$  (where (en) is ethylene diamine) are, respectively, [2008]  
 (a) 6 and 2 (b) 4 and 2  
 (c) 4 and 3 (d) 6 and 3
48. Larger number of oxidation states are exhibited by the actinoids than those by the lanthanoids, the main reason being [2008]  
 (a) 4f orbitals more diffused than the 5f orbitals  
 (b) lesser energy difference between 5f and 6d than between 4f and 5d orbitals  
 (c) more energy difference between 5f and 6d than between 4f and 5d orbitals  
 (d) more reactive nature of the actinoids than the lanthanoids
49. In which of the following complexes of the Co (at. no. 27), will the magnitude of  $\Delta_o$  be the highest? [2008]  
 (a)  $[\text{Co}(\text{CN})_6]^{3-}$  (b)  $[\text{Co}(\text{C}_2\text{O}_4)_3]^{3-}$   
 (c)  $[\text{Co}(\text{H}_2\text{O})_6]^{3+}$  (d)  $[\text{Co}(\text{NH}_3)_6]^{3+}$
50. Amount of oxalic acid present in a solution can be determined by its titration with  $\text{KMnO}_4$  solution in the presence of  $\text{H}_2\text{SO}_4$ . The titration gives unsatisfactory result when carried out in the presence of HCl, because HCl [2008]  
 (a) gets oxidised by oxalic acid to chlorine  
 (b) furnishes  $\text{H}^+$  ions in addition to those from oxalic acid  
 (c) reduces permanganate to  $\text{Mn}^{2+}$   
 (d) Oxidises oxalic acid to carbon dioxide and water
51. Which of the following has an optical isomer [2009]  
 (a)  $[\text{Co}(\text{en})(\text{NH}_3)_2]^{2+}$  (b)  $[\text{Co}(\text{H}_2\text{O})_4(\text{en})]^{3+}$   
 (c)  $[\text{Co}(\text{en})_2(\text{NH}_3)_2]^{3+}$  (d)  $[\text{Co}(\text{NH}_3)_3\text{Cl}]^+$
52. In context with the transition elements, which of the following statements is incorrect? [2009]  
 (a) In the highest oxidation states, the transition metal show basic character and form cationic complexes.  
 (b) In the highest oxidation states of the first five transition elements (Sc to Mn), all the 4s and 3d electrons are used for bonding.
53. Which of the following pairs represent linkage isomers? [2009]  
 (a)  $[\text{Pd}(\text{PPh}_3)_2(\text{NCS})_2]$  and  $[\text{Pd}(\text{PPh}_3)_2(\text{SCN})_2]$   
 (b)  $[\text{Co}(\text{NH}_3)_5\text{NO}_3]\text{SO}_4$  and  $[\text{Co}(\text{NH}_3)_5\text{SO}_4]\text{NO}_3$   
 (c)  $[\text{PtCl}_2(\text{NH}_3)_4]\text{Br}_2$  and  $[\text{PtBr}_2(\text{NH}_3)_4]\text{Cl}_2$   
 (d)  $[\text{Cu}(\text{NH}_3)_4][\text{PtCl}_4]$  and  $[\text{Pt}(\text{NH}_3)_4][\text{CuCl}_4]$

54. Knowing that the chemistry of lanthanoids(Ln) is dominated by its + 3 oxidation state, which of the following statements is incorrect? [2009]
- The ionic size of Ln (III) decrease in general with increasing atomic number
  - Ln (III) compounds are generally colourless.
  - Ln (III) hydroxide are mainly basic in character.
  - Because of the large size of the Ln (III) ions the bonding in its compounds is predominantly ionic in character.
55. A solution containing 2.675 g of  $\text{CoCl}_3 \cdot 6 \text{NH}_3$  (molar mass = 267.5  $\text{g mol}^{-1}$ ) is passed through a cation exchanger. The chloride ions obtained in solution were treated with excess of  $\text{AgNO}_3$  to give 4.78 g of  $\text{AgCl}$  (molar mass = 143.5  $\text{g mol}^{-1}$ ). The formula of the complex is (At. mass of Ag = 108 u) [2010]
- $[\text{Co}(\text{NH}_3)_6]\text{Cl}_3$
  - $[\text{CoCl}_2(\text{NH}_3)_4]\text{Cl}$
  - $[\text{CoCl}_3(\text{NH}_3)_3]$
  - $[\text{CoCl}(\text{NH}_3)_5]\text{Cl}_2$
56. Which one of the following has an optical isomer? [2010]
- $[\text{Zn}(\text{en})(\text{NH}_3)_2]^{2+}$
  - $[\text{Co}(\text{en})_3]^{3+}$
  - $[\text{Co}(\text{H}_2\text{O})_4(\text{en})]^{3+}$
  - $[\text{Zn}(\text{en})_2]^{2+}$
- (en = ethylenediamine)
57. Which of the following facts about the complex  $[\text{Cr}(\text{NH}_3)_6]\text{Cl}_3$  is wrong? [2011]
- The complex involves  $d^2sp^3$  hybridisation and is octahedral in shape.
  - The complex is paramagnetic.
  - The complex is an outer orbital complex
  - The complex gives white precipitate with silver nitrate solution.
58. In context of the lanthanoids, which of the following statements is not correct? [2011]
- There is a gradual decrease in the radii of the members with increasing atomic number in the series.
  - All the members exhibit +3 oxidation state.
  - Because of similar properties the separation of lanthanoids is not easy.
  - Availability of 4f electrons results in the formation of compounds in +4 state for all the members of the series.
59. The magnetic moment (spin only) of  $[\text{NiCl}_4]^{2-}$  is : [2011]
- 1.82 BM
  - 5.46 BM
  - 2.82 BM
  - 1.41 BM
60. The outer electron configuration of Gd (Atomic No. : 64) is : [2011]
- $4f^3 5d^5 6s^2$
  - $4f^8 5d^0 6s^2$
  - $4f^4 5d^4 6s^2$
  - $4f^7 5d^1 6s^2$
61. Which among the following will be named as dibromidobis(ethylene diamine) chromium (III) bromide? [2012]
- $[\text{Cr}(\text{en})_3]\text{Br}_3$
  - $[\text{Cr}(\text{en})_2\text{Br}_2]\text{Br}$
  - $[\text{Cr}(\text{en})\text{Br}_4]^-$
  - $[\text{Cr}(\text{en})\text{Br}_2]\text{Br}$
62. Iron exhibits +2 and + 3 oxidation states. Which of the following statements about iron is incorrect ? [2012]
- Ferrous oxide is more basic in nature than the ferric oxide.
  - Ferrous compounds are relatively more ionic than the corresponding ferric compounds.
  - Ferrous compounds are less volatile than the corresponding ferric compounds.
  - Ferrous compounds are more easily hydrolysed than the corresponding ferric compounds.
63. Which of the following complex species is not expected to exhibit optical isomerism ? [JEE M 2013]
- $[\text{Co}(\text{en})_3]^{3+}$
  - $[\text{Co}(\text{en})_2\text{Cl}_2]^+$
  - $[\text{Co}(\text{NH}_3)_3\text{Cl}_3]$
  - $[\text{Co}(\text{en})(\text{NH}_3)_2\text{Cl}_2]^+$
64. Which of the following arrangements does not represent the correct order of the property stated against it ? [JEE M 2013]
- $\text{V}^{2+} < \text{Cr}^{2+} < \text{Mn}^{2+} < \text{Fe}^{2+}$  : paramagnetic behaviour
  - $\text{Ni}^{2+} < \text{Co}^{2+} < \text{Fe}^{2+} < \text{Mn}^{2+}$  : ionic size
  - $\text{Co}^{3+} < \text{Fe}^{3+} < \text{Cr}^{3+} < \text{Sc}^{3+}$  : stability in aqueous solution
  - $\text{Sc} < \text{Ti} < \text{Cr} < \text{Mn}$  : number of oxidation states
65. Four successive members of the first row transition elements are listed below with atomic numbers. Which one of them is expected to have the highest  $E_{M^{3+}/M^{2+}}^0$  value ? [JEE M 2013]
- Cr(Z=24)
  - Mn(Z=25)
  - Fe(Z=26)
  - Co(Z=27)
66. The octahedral complex of a metal ion  $\text{M}^{3+}$  with four monodentate ligands  $L_1, L_2, L_3$  and  $L_4$  absorb wavelengths in the region of red, green, yellow and blue, respectively. The increasing order of ligand strength of the four ligands is: [JEE M 2014]
- $L_4 < L_3 < L_2 < L_1$
  - $L_1 < L_3 < L_2 < L_4$
  - $L_3 < L_2 < L_4 < L_1$
  - $L_1 < L_2 < L_4 < L_3$

67. Which series of reactions correctly represents chemical reactions related to iron and its compound? [JEE M 2014]

- (a)  $\text{Fe} \xrightarrow{\text{dil. H}_2\text{SO}_4} \text{FeSO}_4 \xrightarrow{\text{H}_2\text{SO}_4, \text{O}_2} \text{Fe}_2(\text{SO}_4)_3 \xrightarrow{\text{heat}} \text{Fe}$
- (b)  $\text{Fe} \xrightarrow{\text{O}_2, \text{heat}} \text{FeO} \xrightarrow{\text{dil. H}_2\text{SO}_4} \text{FeSO}_4 \xrightarrow{\text{heat}} \text{Fe}$
- (c)  $\text{Fe} \xrightarrow{\text{Cl}_2, \text{heat}} \text{FeCl}_3 \xrightarrow{\text{heat, air}} \text{FeCl}_2 \xrightarrow{\text{Zn}} \text{Fe}$
- (d)  $\text{Fe} \xrightarrow{\text{O}_2, \text{heat}} \text{Fe}_3\text{O}_4 \xrightarrow{\text{CO}, 600^\circ\text{C}} \text{FeO} \xrightarrow{\text{CO}, 700^\circ\text{C}} \text{Fe}$

68. Which of the following compounds is not colored yellow? [JEE M 2015]

- (a)  $(\text{NH}_4)_3[\text{As}(\text{Mo}_3\text{O}_{10})_4]$  (b)  $\text{BaCrO}_4$   
 (c)  $\text{Zn}_2[\text{Fe}(\text{CN})_6]$  (d)  $\text{K}_3[\text{Co}(\text{NO}_2)_6]$

69. Match the catalysts to the correct processes: [JEE M 2015]

- | Catalyst                   | Process                             |
|----------------------------|-------------------------------------|
| (A) $\text{TiCl}_4$        | (i) Wacker process                  |
| (B) $\text{PdCl}_2$        | (ii) Ziegler - Natta polymerization |
| (C) $\text{CuCl}_2$        | (iii) Contact process               |
| (D) $\text{V}_2\text{O}_5$ | (iv) Deacon's process               |
- (a) (A) - (ii), (B) - (iii), (C) - (iv), (D) - (i)  
 (b) (A) - (iii), (B) - (i), (C) - (ii), (D) - (iv)  
 (c) (A) - (iii), (B) - (ii), (C) - (iv), (D) - (i)  
 (d) (A) - (ii), (B) - (i), (C) - (iv), (D) - (iii)

70. The number of geometric isomers that can exist for square planar complex  $[\text{Pt}(\text{Cl})(\text{py})(\text{NH}_3)(\text{NH}_2\text{OH})]^+$  is (py = pyridine): [JEE M 2015]

- (a) 4 (b) 6  
 (c) 2 (d) 3

71. The color of  $\text{KMnO}_4$  is due to: [JEE M 2015]

- (a)  $\text{L} \rightarrow \text{M}$  charge transfer transition  
 (b)  $\sigma - \sigma^*$  transition  
 (c)  $\text{M} \rightarrow \text{L}$  charge transfer transition  
 (d)  $d - d$  transition

72. Which of the following compounds is metallic and ferromagnetic? [JEE M 2016]

- (a)  $\text{VO}_2$  (b)  $\text{MnO}_2$   
 (c)  $\text{TiO}_2$  (d)  $\text{CrO}_2$

73. Which one of the following complexes shows optical isomerism? [JEE M 2016]

- (a) *trans*  $[\text{Co}(\text{en})_2\text{Cl}_2]\text{Cl}$   
 (b)  $[\text{Co}(\text{NH}_3)_4\text{Cl}_2]\text{Cl}$   
 (c)  $[\text{Co}(\text{NH}_3)_3\text{Cl}_3]$   
 (d) *cis*  $[\text{Co}(\text{en})_2\text{Cl}_2]\text{Cl}$   
 (en = ethylenediamine)

74. The pair having the same magnetic moment is:

[At. No.: Cr = 24, Mn = 25, Fe = 26, Co = 27]

- (a)  $[\text{Mn}(\text{H}_2\text{O})_6]^{2+}$  and  $[\text{Cr}(\text{H}_2\text{O})_6]^{2+}$   
 (b)  $[\text{CoCl}_4]^{2-}$  and  $[\text{Fe}(\text{H}_2\text{O})_6]^{2+}$   
 (c)  $[\text{Cr}(\text{H}_2\text{O})_6]^{2+}$  and  $[\text{CoCl}_4]^{2-}$   
 (d)  $[\text{Cr}(\text{H}_2\text{O})_6]^{2+}$  and  $[\text{Fe}(\text{H}_2\text{O})_6]^{2+}$

[JEE M 2016]

# CHAPTER 18

# Haloalkanes and Haloarenes

## Section-A

## JEE Advanced/ IIT-JEE

### A Fill in the Blanks

- The halogen which is most reactive in the halogenation of alkanes under sunlight is .....  
(chlorine, bromine, iodine) (1981 - 1 Mark)
- The compound prepared by the action of magnesium on dry ethyl bromide in ether is known as ..... reagent.  
(1982 - 1 Mark)
- The interaction of elemental sulphur with Grignard reagent gives .....  
(1991 - 1 Mark)
- Vinyl chloride on reaction with dimethyl copper gives .....  
(1997 - 1 Mark)

### B True / False

- m*-Chlorobromobenzene is an isomer of *m*-bromochlorobenzene. (1985 - ½ Mark)
- The reaction of vinyl chloride with hydrogen iodide to give 1-chloro-1-iodoethane is an example of anti-Markovnikov's rule. (1989 - 2 Marks)

### C MCQs with One Correct Answer

- Chlorobenzene can be prepared by reacting aniline with :  
(1984 - 1 Mark)
  - hydrochloric acid
  - cuprous chloride
  - chlorine in presence of anhydrous aluminium chloride
  - nitrous acid followed by heating with cuprous chloride
- The reaction of toluene with chlorine in presence of ferric chloride gives predominantly :  
(1986 - 1 Mark)
  - benzoyl chloride
  - m*-chlorotoluene
  - benzyl chloride
  - o*- and *p*-chlorotoluene
- The reaction conditions leading to the best yields of  $C_2H_5Cl$  are :  
(1986 - 1 Mark)
  - $C_2H_6$  (excess) +  $Cl_2 \xrightarrow{uv\ light}$
  - $C_2H_6 + Cl_2 \xrightarrow[room\ temperature]{dark}$
  - $C_2H_6 + Cl_2$  (excess)  $\xrightarrow{uv\ light}$
  - $C_2H_6 + Cl_2 \xrightarrow{uv\ light}$

- n*-Propyl bromide on treatment with ethanolic potassium hydroxide produces  
(1987 - 1 Mark)
  - Propane
  - Propene
  - Propyne
  - Propanol
- The number of structural and configurational isomers of a bromo compound,  $C_5H_9Br$ , formed by the addition of HBr to 2-pentyne respectively are  
(1988 - 1 Mark)
  - 1 and 2
  - 2 and 4
  - 4 and 2
  - 2 and 1
- 1-Chlorobutane on reaction with alcoholic potash gives  
(1991 - 1 Mark)
  - 1-butene
  - 1-butanol
  - 2-butene
  - 2-butanol
- The chief reaction product of reaction between *n*-butane and bromine at  $130^\circ C$  is :  
(1995S)
  - $CH_3CH_2CH_2CH_2Br$
  - $CH_3CH_2\underset{\begin{array}{c} | \\ CH_3 \end{array}}{CH}Br$
  - $CH_3 - CH_2\underset{\begin{array}{c} | \\ CH_2Br \end{array}}{CH}Br$
  - $CH_3CH_2\underset{\begin{array}{c} | \\ CH_3 \end{array}}{C}Br_2$
- Isobutyl magnesium bromide with dry ether and ethyl alcohol gives :  
(1995S)
  - $CH_3\underset{\begin{array}{c} | \\ CH_3 \end{array}}{CH}CH_2OH$  &  $CH_3CH_2MgBr$
  - $CH_3\underset{\begin{array}{c} | \\ CH_3 \end{array}}{CH}CH_3$  &  $MgBr(OC_2H_5)$
  - $CH_3\underset{\begin{array}{c} | \\ CH_3 \end{array}}{CH}, CH = CH_2$  &  $Mg(OH)Br$
  - $CH_3\underset{\begin{array}{c} | \\ CH_3 \end{array}}{CH}CH_3$  &  $CH_3CH_2OMgBr$
- $(CH_3)_3CMgCl$  on reaction with  $D_2O$  produces :  
(1997 - 1 Mark)
  - $(CH_3)_3CD$
  - $(CH_3)_3OD$
  - $(CD_3)_3CD$
  - $(CD_3)_3OD$

10. A solution of (+) -2-chloro-2-phenylethane in toluene racemises slowly in the presence of small amount of  $\text{SbCl}_5$  due to the formation of (1999 - 2 Marks)

- (a) carbanion (b) carbene  
(c) free-radical (d) carbocation

11. Identify the set of reagent / reaction conditions 'X' and 'Y' in the following set of transformations (2002S)

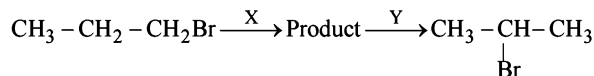

- (a) X = dilute aqueous NaOH, 20°C; Y = HBr/acetic acid, 20°C  
(b) X = concentrated alcoholic NaOH, 80°C; Y = HBr/acetic acid, 20°C  
(c) X = dilute aqueous NaOH, 20°C; Y =  $\text{Br}_2/\text{CHCl}_3$ , 0°C  
(d) X = concentrated alcoholic NaOH, 80°C; Y =  $\text{Br}_2/\text{CHCl}_3$ , 0°C

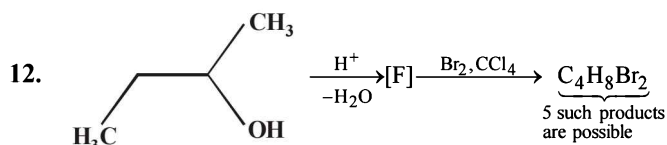

How many structures for F are possible? (2003S)

- (a) 2 (b) 5  
(c) 6 (d) 3

13. What would be the product formed when 1-bromo-3-chlorocyclobutane reacts with two equivalents of metallic sodium in ether? (2005S)

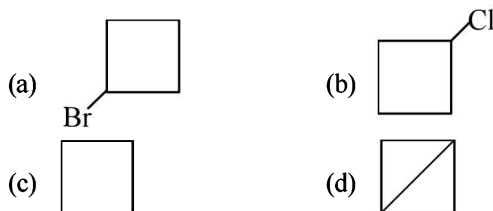

14. When phenyl magnesium bromide reacts with *tert*-butanol, the product would be (2005S)

- (a) Benzene (b) Phenol  
(c) *ter*-butylbenzene (d) *ter*-butyl phenyl ether

15. The reagent(s) for the following conversion,

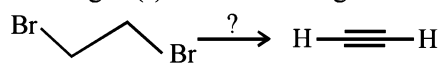

is/are (2007)

- (a) alcoholic KOH  
(b) alcoholic KOH followed by  $\text{NaNH}_2$   
(c) aqueous KOH followed by  $\text{NaNH}_2$   
(d)  $\text{Zn}/\text{CH}_3\text{OH}$

16. The major product of the following reaction is - (2008)

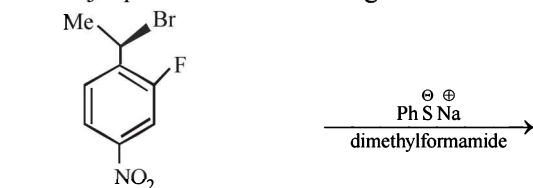

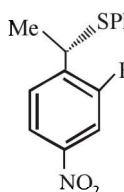
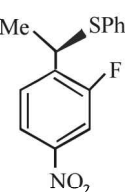
- (a)  (b) 

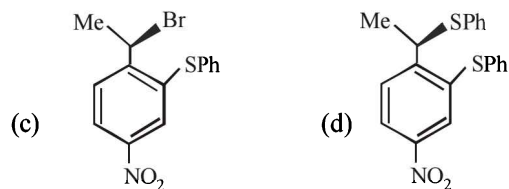

## D MCQs with One or More Than One Correct

1. Aryl halides are less reactive towards nucleophilic substitution reaction as compared to alkyl halides due to :

(1990 - 1 Mark)

- (a) The formation of less stable carbonium ion  
(b) Resonance stabilization  
(c) Longer carbon-halogen bond  
(d) The inductive effect  
(e)  $sp^2$  hybridized carbon attached to the halogen.

2. Benzyl chloride ( $\text{C}_6\text{H}_5\text{CH}_2\text{Cl}$ ) can be prepared from toluene by chlorination with (1998 - 2 Marks)

- (a)  $\text{SO}_2\text{Cl}_2$  (b)  $\text{SOCl}_2$   
(c)  $\text{Cl}_2$  (d)  $\text{NaOCl}$

## E Subjective Problems

1. (a) Show by chemical equations only, how you would prepare the following from the indicated starting materials. Specify the reagents in each step of the synthesis.

- (i) Hexachlorethane,  $\text{C}_2\text{Cl}_6$ , from calcium carbide.  
(ii) Chloroform from carbon disulphide.

(b) Give one chemical test which would distinguish between  $\text{C}_2\text{H}_5\text{OH}$  from  $\text{CHCl}_3$ . (1979)

2. Write the structural formula of the major product in each of the following cases :

(i) chloroform reacts with aniline in the presence of excess alkali (1981 - 1/2 Mark)

(ii) bromoethane reacts with one-half of the molar quantity of silver carbonate. (1981 - 1/2 Mark)

(iii)  $(\text{CH}_3)_2\text{C}(\text{Cl})-\text{CH}_2\text{CH}_3 \xrightarrow{\text{alc. KOH}}$  (1992 - 1 Mark)

(iv)  $\text{CH}_3\text{CH}_2\text{CHCl}_2 \xrightarrow[\text{alkali}]{\text{boil}}$  (1992 - 1 Mark)

(v)  $\text{C}_6\text{H}_5-\text{CH}_2-\underset{\text{Br}}{\text{CH}}-\text{CH}_3 \xrightarrow[\text{KOH}, \Delta]{\text{alcoholic}} \text{?} \xrightarrow{\text{HBr}} \text{?}$  (1993 - 1 Mark)

(vi)  $\text{Me}-\text{C}_6\text{H}_4-\text{I} + \text{Cu} + \text{heat} \longrightarrow \text{-----}$  (1997 - 1 Mark)

(vii)  $\text{C}_6\text{H}_5\text{CH}_2\text{CHClC}_6\text{H}_5 \xrightarrow[\text{heat}]{\text{alcoholic KOH}} 2 \text{ Products}$  (1998 - 2 Marks)

(viii)  $\text{CH}_3-\underset{\text{CH}_3}{\overset{\text{CH}_3}{\text{C}}}-\text{CH}_2\text{Br} \xrightarrow[\Delta]{\text{C}_2\text{H}_5\text{OH}}$  (2000 - 1 Mark)

3. Give reasons for the following :  
 (i) 7-Bromo-1, 3, 5-cycloheptatriene exists as ionic compound, while 5-bromo-1, 3-cyclopentadiene does not ionise even in presence of  $\text{Ag}^+$  ion. Explain. (2004 - 2 Marks)

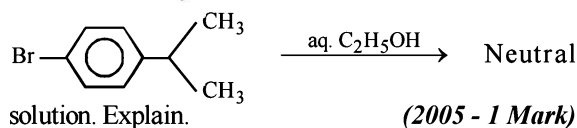
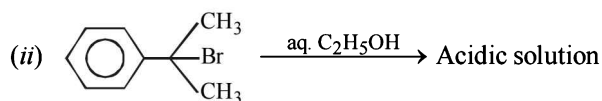

4. State the conditions under which the following preparation are carried out. Give the necessary equations which need not be balanced :

(i) Lead tetraethyl from sodium-lead alloy (1983 - 1 Mark)

(ii) Methyl chloride from aluminium carbide (1983 - 1 Mark)

5. Write the structure of all the possible isomers of dichloroethene. Which of them will have zero dipole moment? (1985 - 2 Marks)

6. What happens when excess chlorine is passed through boiling toluene in the presence of sunlight? (1987 - 1 Mark)

7. What effect should the following resonance of vinyl chloride have on its dipole moment? (1987 - 1 Mark)

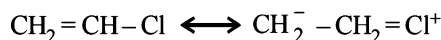

8. An organic compound X, on analysis gives 24.24 per cent carbon and 4.04 per cent hydrogen. Further, sodium extract of 1.0 g of X gives 2.90 g of silver chloride with acidified silver nitrate solution. The compound X may be represented by two isomeric structures, Y and Z. Y on treatment with aqueous potassium hydroxide solution gives a dihydroxy compound while Z on similar treatment gives ethanal. Find out the molecular formula of X and give the structures of Y and Z. (1989 - 4 Marks)

9. Draw the stereochemical structures of the products in the following reaction : (1994 - 4 Marks)

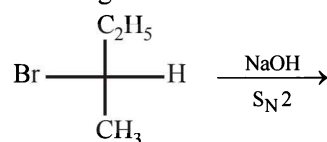

10. An alkyl halide, X, of formula  $\text{C}_6\text{H}_{13}\text{Cl}$  on treatment with potassium tertiary butoxide gives two isomeric alkenes Y and Z ( $\text{C}_6\text{H}_{12}$ ). Both alkenes on hydrogenation give 2, 3-dimethylbutane. Predict the structures of X, Y and Z. (1996 - 3 Marks)

11. How will you prepare *m*-bromiodobenzene from benzene (in not more than 5-7 steps)? (1996 - 2 Marks)

12. Cyclobutyl bromide on treatment with magnesium in dry ether forms an organometallic (A). The organometallic reacts with ethanal to give an alcohol (B) after mild acidification. Prolonged treatment of alcohol (B) with an equivalent amount of HBr gives 1-bromo-1-methylcyclopentane (C). Write the structures of (A), (B) and explain how (C) is obtained from (B). (2001 - 5 Marks)

## H Assertion & Reason Type Questions

1. Read the following Statement-1 (Assertion) and Statement-2 (Reason) and answer as per the options given below :

**Statement-1 :** Bromobenzene upon reaction with  $\text{Br}_2/\text{Fe}$  gives 1,4-dibromobenzene as the major product. (2008S)

**Statement-2 :** In bromobenzene, the inductive effect of the bromo group is more dominant than the mesomeric effect in directing the incoming electrophile.

- (a) Statement-1 is True, Statement-2 is True; Statement-2 is a correct explanation for Statement-1.  
 (b) Statement-1 is True, Statement-2 is True; Statement-2 is NOT a correct explanation for Statement-1  
 (c) Statement-1 is True, Statement-2 is False  
 (d) Statement-1 is False, Statement-2 is True

## I Integer Value Correct Type

1. The total number of alkenes possible by dehydrobromination of 3-bromo-3-cyclopentylhexane using alcoholic KOH is (2011)
2. In the following monobromination reaction, the number of possible chiral products is (JEE Adv. 2016)

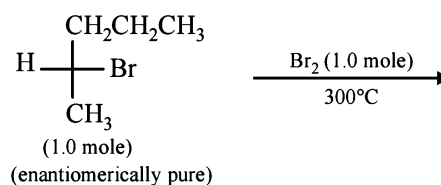

## Section-B JEE Main / AIEEE

1. Bottles containing  $\text{C}_6\text{H}_5\text{I}$  and  $\text{C}_6\text{H}_5\text{CH}_2\text{I}$  lost their original labels. They were labelled A and B for testing. A and B were separately taken in test tubes and boiled with NaOH solution. The end solution in each tube was made acidic with dilute  $\text{HNO}_3$  and then some  $\text{AgNO}_3$  solution was added. Substance B gave a yellow precipitate. Which one of the following statements is true for this experiment? [2003]
- (a) A and  $\text{C}_6\text{H}_5\text{CH}_2\text{I}$   
 (b) B and  $\text{C}_6\text{H}_5\text{I}$   
 (c) Addition of  $\text{HNO}_3$  was unnecessary  
 (d) A was  $\text{C}_6\text{H}_5\text{I}$
2. The compound formed on heating chlorobenzene with chloral in the presence of concentrated sulphuric acid, is (a) freon (b) DDT [2004]  
 (c) gammexene (d) hexachloroethane
3. Tertiary alkyl halides are practically inert to substitution by  $\text{S}_\text{N}2$  mechanism because of [2005]  
 (a) steric hindrance (b) inductive effect  
 (c) instability (d) insolubility
4. Alkyl halides react with dialkyl copper reagents to give (a) alkenyl halides (b) alkanes [2005]  
 (c) alkyl copper halides (d) alkenes

5. Elimination of bromine from 2-bromobutane results in the formation of— [2005]  
 (a) Predominantly 2-butyne  
 (b) Predominantly 1-butene  
 (c) Predominantly 2-butene  
 (d) equimolar mixture of 1 and 2-butene
6. Phenyl magnesium bromide reacts with methanol to give [2006]  
 (a) a mixture of toluene and  $Mg(OH)Br$   
 (b) a mixture of phenol and  $Mg(Me)Br$   
 (c) a mixture of anisole and  $Mg(OH)Br$   
 (d) a mixture of benzene and  $Mg(OMe)Br$
7. Fluorobenzene ( $C_6H_5F$ ) can be synthesized in the laboratory [2006]  
 (a) by direct fluorination of benzene with  $F_2$  gas  
 (b) by reacting bromobenzene with  $NaF$  solution  
 (c) by heating phenol with  $HF$  and  $KF$   
 (d) from aniline by diazotisation followed by heating the diazonium salt with  $HF_4$
8. Reaction of *trans* 2-phenyl-1-bromocyclopentane on reaction with alcoholic  $KOH$  produces [2006]  
 (a) 1-phenylcyclopentene (b) 3-phenylcyclopentene  
 (c) 4-phenylcyclopentene (d) 2-phenylcyclopentene
9. The structure of the major product formed in the following reaction [2006]

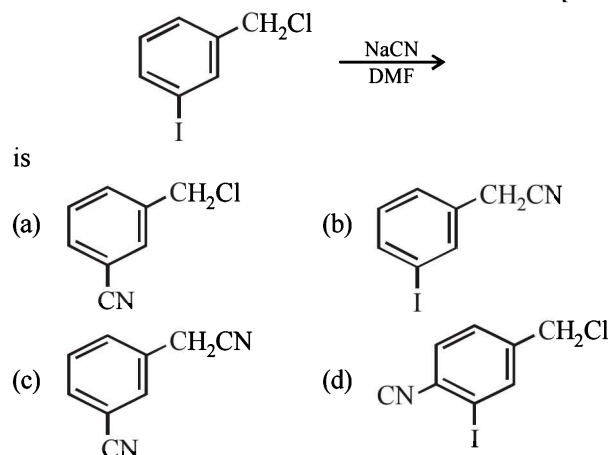

10. Which of the following is the correct order of decreasing  $S_N2$  reactivity? [2007]  
 (a)  $R_2CHX > R_2CX > RCH_2X$   
 (b)  $RCHX > R_2CX > R_2CHX$   
 (c)  $RCH_2X > R_2CHX > R_2CX$   
 (d)  $R_2CX > R_2CHX > RCH_2X$   
 (X is a halogen)
11. The organic chloro compound, which shows complete stereochemical inversion during a  $S_N2$  reaction, is [2008]  
 (a)  $(C_2H_5)_2CHCl$  (b)  $(CH_3)_3CCl$   
 (c)  $(CH_3)_2CHCl$  (d)  $CH_3Cl$
12. Consider the following bromides :

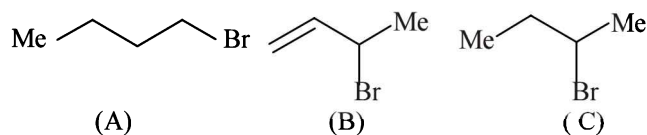

The correct order of  $S_N1$  reactivity is [2010]

- (a)  $B > C > A$  (b)  $B > A > C$   
 (c)  $C > B > A$  (d)  $A > B > C$
13. How many chiral compounds are possible on monochlorination of 2-methyl butane? [2012]  
 (a) 8 (b) 2  
 (c) 4 (d) 6
14. What is DDT among the following? [2012]  
 (a) Greenhouse gas  
 (b) A fertilizer  
 (c) Biodegradable pollutant  
 (d) Non-biodegradable pollutant
15. Compound (A),  $C_8H_9Br$ , gives a white precipitate when warmed with alcoholic  $AgNO_3$ . Oxidation of (A) gives an acid (B),  $C_8H_6O_4$ . (B) easily forms anhydride on heating. Identify the compound (A). [JEE M 2013]

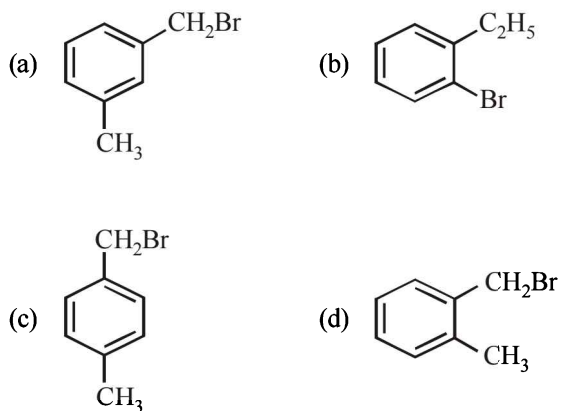

16. In  $S_N2$  reactions, the correct order of reactivity for the following compounds: [JEE M 2014]  
 $CH_3Cl$ ,  $CH_3CH_2Cl$ ,  $(CH_3)_2CHCl$  and  $(CH_3)_3CCl$  is:  
 (a)  $CH_3Cl > (CH_3)_2CHCl > CH_3CH_2Cl > (CH_3)_3CCl$   
 (b)  $CH_3Cl > CH_3CH_2Cl > (CH_3)_2CHCl > (CH_3)_3CCl$   
 (c)  $CH_3CH_2Cl > CH_3Cl > (CH_3)_2CHCl > (CH_3)_3CCl$   
 (d)  $(CH_3)_2CHCl > CH_3CH_2Cl > CH_3Cl > (CH_3)_3CCl$
17. The major organic compound formed by the reaction of 1, 1, 1-trichloroethane with silver powder is: [JEE M 2014]  
 (a) Acetylene (b) Ethene  
 (c) 2-Butyne (d) 2-Butene
18. The synthesis of alkyl fluorides is best accomplished by : [JEE M 2015]

- (a) Finkelstein reaction (b) Swarts reaction  
 (c) Free radical fluorination (d) Sandmeyer's reaction



## CHAPTER

## 19

Alcohols, Phenols  
and Ethers

## Section-A

## JEE Advanced/ IIT-JEE

## A Fill in the Blanks

- Ethanol vapour is passed over heated copper and the product is treated with aqueous NaOH. The final product is ..... (1983 - 1 Mark)
- The acidity of phenol is due to the ..... of its anion. (1984 - 1 Mark)
- Formation of phenol from chlorobenzene is an example of ..... aromatic substitution. (1989 - 1 Mark)
- Phenol is acidic because of resonance stabilization of its conjugate base, namely ..... (1990 - 1 Mark)
- Aliphatic ethers are purified by shaking with a solution of ferrous salt to remove ..... which are formed on prolonged standing in contact with air. (1992 - 1 Mark)
- Glycerine contains one ..... hydroxy group. (1997 - 1 Mark)

## B True / False

- Sodium ethoxide is prepared by reacting ethanol with aqueous sodium hydroxide. (1986 - 1 Mark)

## C MCQs with One Correct Answer

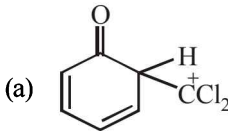
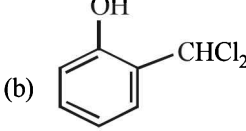
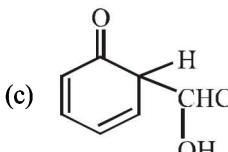
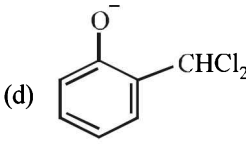
- Ethyl alcohol is heated with conc  $\text{H}_2\text{SO}_4$  the product formed is (1980)
  - $\text{H}_3\text{C}-\overset{\text{O}}{\parallel}{\text{C}}-\text{OC}_2\text{H}_5$
  - $\text{C}_2\text{H}_6$
  - $\text{C}_2\text{H}_4$
  - $\text{C}_2\text{H}_2$
- Which of the following is basic (1980)
  - $\text{CH}_3-\text{CH}_2-\text{OH}$
  - $\text{OH}-\text{CH}_2-\text{CH}_2-\text{OH}$
  - $\text{H}-\text{O}-\text{O}-\text{H}$
  - $\text{H}_3\text{C}-\overset{\text{O}}{\parallel}{\text{C}}-\text{OH}$
- The compound which reacts fastest with Lucas reagent at room temperature is (1981 - 1 Mark)
  - butan-1-ol
  - butan-2-ol
  - 2-methylpropan-1-ol
  - 2-methylpropan-2-ol
- A compound that gives a positive iodoform test is (1982 - 1 Mark)
  - 1-pentanol
  - 2-pentanone
  - 3-pentanone
  - pentanal
- Diethyl ether on heating with conc. HI gives two moles of (1983 - 1 Mark)
  - ethanol
  - iodoform
  - ethyl iodide
  - methyl iodide
- An industrial method of preparation of methanol is : (1984 - 1 Mark)
  - catalytic reduction of carbon monoxide in presence of  $\text{ZnO}-\text{Cr}_2\text{O}_3$
  - by reacting methane with steam at  $900^\circ\text{C}$  with a nickel catalyst
  - by reducing formaldehyde with lithium aluminium hydride
  - by reacting formaldehyde with aqueous sodium hydroxide solution
- When phenol is treated with excess bromine water, it gives: (1984 - 1 Mark)
  - m*-Bromophenol
  - o*- and *p*-Bromophenol
  - 2,4-Dibromophenol
  - 2,4,6-Tribromophenol
- HBr reacts fastest with : (1986 - 1 Mark)
  - 2-methylpropan-2-ol
  - propan-1-ol
  - propan-2-ol
  - 2-methylpropan-1-ol
- Which of the following compounds is oxidised to prepare methyl ethyl ketone? (1987 - 1 Mark)
  - 2-Propanol
  - 1-Butanol
  - 2-Butanol
  - t*-Butyl alcohol
- Phenol reacts with bromine in carbon disulphide at low temperature to give (1988 - 1 Mark)
  - m*-bromophenol
  - o*- and *p*-bromophenol
  - p*-bromophenol
  - 2,4,6-tribromophenol
- Chlorination of toluene in the presence of light and heat followed by treatment with aqueous NaOH gives (1990 - 1 Mark)
  - o*-Cresol
  - p*-Cresol
  - 2,4-Dihydroxytoluene
  - Benzoic acid
- When phenol is reacted with  $\text{CHCl}_3$  and NaOH followed by acidification, salicylaldehyde is obtained. Which of the following species are involved in the above mentioned reaction as intermediate? (1995S)
  - 
  - 
  - 
  - 

13. The compound that will react most readily with NaOH to form methanol is (2001S)

- (a)  $(\text{CH}_3)_4\text{N}^+\text{I}^-$  (b)  $\text{CH}_3\text{OCH}_3$   
(c)  $(\text{CH}_3)_3\text{S}^+\text{I}^-$  (d)  $(\text{CH}_3)_3\text{CCl}$

14. 1-Propanol and 2-propanol can be best distinguished by (2001S)

- (a) oxidation with alkaline  $\text{KMnO}_4$  followed by reaction with Fehling solution  
(b) oxidation with acidic dichromate followed by reaction with Fehling solution  
(c) oxidation by heating with copper followed by reaction with Fehling solution  
(d) oxidation with concentrated  $\text{H}_2\text{SO}_4$  followed by reaction with Fehling solution

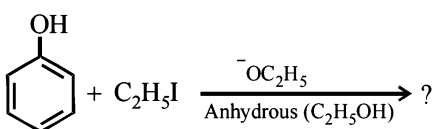
15.  (2003S)

- (a)  $\text{C}_6\text{H}_5\text{OC}_2\text{H}_5$  (b)  $\text{C}_2\text{H}_5\text{OC}_2\text{H}_5$   
(c)  $\text{C}_6\text{H}_5\text{OC}_6\text{H}_5$  (d)  $\text{C}_6\text{H}_5\text{I}$

16. The product of acid catalyzed hydration of 2-phenylpropene is (2004S)

- (a) 3-phenyl-2-propanol (b) 1-phenyl-2-propanol  
(c) 2-phenyl-2-propanol (d) 2-phenyl-1-propanol





17. The best method to prepare cyclohexene from cyclohexanol is by using (2005S)

- (a) Conc.  $\text{HCl} + \text{ZnCl}_2$  (b) Conc.  $\text{H}_3\text{PO}_4$   
(c)  $\text{HBr}$  (d) Conc.  $\text{HCl}$

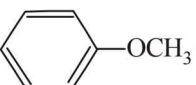
18. The increasing order of boiling points of the below mentioned alcohols is (2006 - 3M, -1)

- (I) 1,2-dihydroxybenzene (II) 1,3-dihydroxybenzene  
(III) 1,4-dihydroxybenzene (IV) Hydroxybenzene  
(a)  $\text{I} < \text{II} < \text{IV} < \text{III}$  (b)  $\text{I} < \text{II} < \text{III} < \text{IV}$   
(c)  $\text{IV} < \text{II} < \text{I} < \text{III}$  (d)  $\text{IV} < \text{I} < \text{II} < \text{III}$

19. In the reaction  the products are

- (a)  and  $\text{H}_2$  (2010)  
(b)  and  $\text{CH}_3\text{Br}$   
(c)  and  $\text{CH}_3\text{OH}$   
(d)  and  $\text{CH}_3\text{Br}$

20. For the identification of  $\beta$ -naphthol using dye test, it is necessary to use (JEE Adv. 2014)

- (a) Dichloromethane solution of  $\beta$ -naphthol  
(b) Acidic solution of  $\beta$ -naphthol  
(c) Neutral solution of  $\beta$ -naphthol  
(d) Alkaline solution of  $\beta$ -naphthol

21. The acidic hydrolysis of ether (X) shown below is fastest when (JEE Adv. 2014)

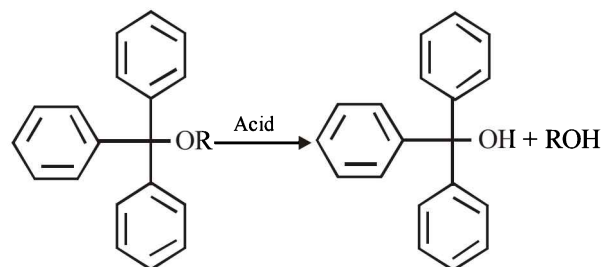

- (a) One phenyl group is replaced by a methyl group  
(b) One phenyl group is replaced by a *para*-methoxyphenyl group  
(c) Two phenyl groups are replaced by two *para*-methoxyphenyl groups  
(d) No structural change is made to X

## D MCQs with One or More Than One Correct

1. The reaction of  $\text{CH}_3\text{CH}=\text{CH}-\text{C}_6\text{H}_4-\text{OH}$  with  $\text{HBr}$  gives (1998 - 2 Marks)

- (a)  $\text{CH}_3\text{CHBrCH}_2-\text{C}_6\text{H}_4-\text{OH}$   
(b)  $\text{CH}_3\text{CH}_2\text{CHBr}-\text{C}_6\text{H}_4-\text{OH}$   
(c)  $\text{CH}_3\text{CHBrCH}_2-\text{C}_6\text{H}_3(\text{Br})-\text{OH}$   
(d)  $\text{CH}_3\text{CH}_2\text{CHBr}-\text{C}_6\text{H}_3(\text{Br})-\text{OH}$

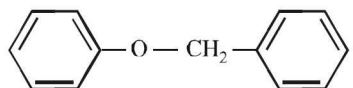
2. The ether  when treated with  $\text{HI}$  produces (1999 - 3 Marks)

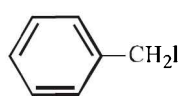
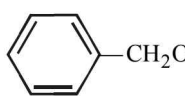
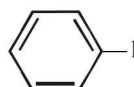
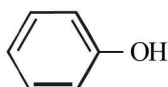
- (a)  (b)   
(c)  (d) 

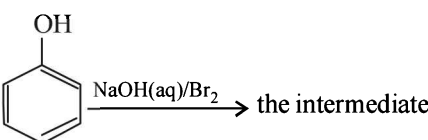
3. In the reaction  the intermediate (s) is (are) (2010)

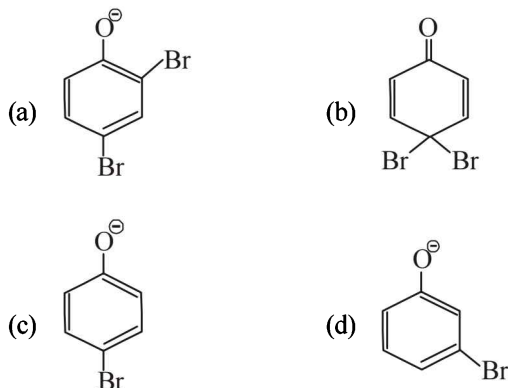

4. The major product(s) of the following reaction is(are) (JEE Adv. 2013)

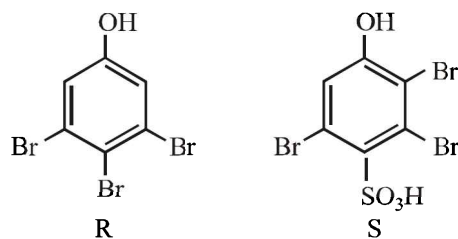
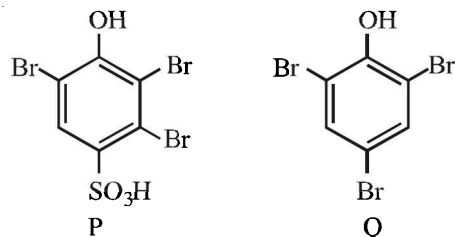
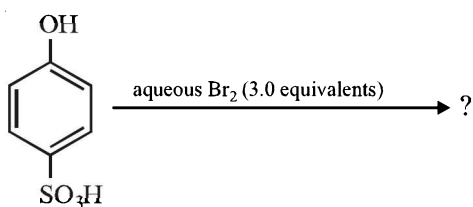

- (a) P (b) Q  
(c) R (d) S
5. The correct combination of names for isomeric alcohols with molecular formula  $C_4H_{10}O$  is/are (JEE Adv. 2014)
- (a) Tert-butanol and 2-methylpropan-2-ol  
(b) Tert-butanol and 1, 1-dimethylethan-1-ol  
(c) n-butanol and butan-1-ol  
(d) Isobutyl alcohol and 2-methylpropan-1-ol
6. The reactivity of compound Z with different halogens under appropriate conditions is given below: (JEE Adv. 2014)

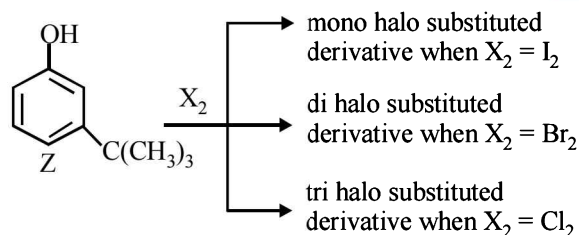

The observed pattern of electrophilic substitution can be explained by

- (a) The steric effect of the halogen  
(b) The steric effect of the *tert*-butyl group  
(c) The electronic effect of the phenolic group  
(d) The electronic effect of the *tert*-butyl group
7. The major product U in the following reactions is

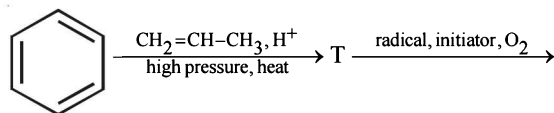

(JEE Adv. 2015)

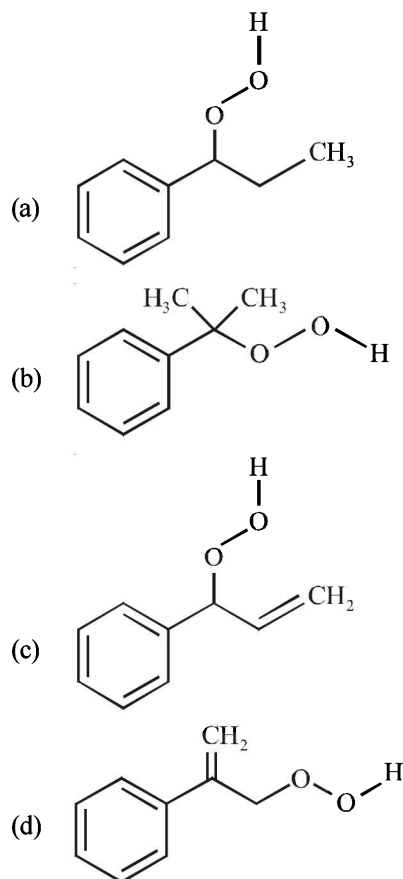

## E Subjective Problems

1. An organic liquid (A), containing C, H and O with boiling point :  $78^\circ\text{C}$ , and possessing a rather pleasant odour, on heating with concentrated sulphuric acid gives a gaseous product (B) – with the empirical formula,  $\text{CH}_2$ . 'B' decolourises bromine water as well as alkaline  $\text{KMnO}_4$  solution and takes up one mole of  $\text{H}_2$  (per mole of 'B') in the presence of finely divided nickel at high temperature. Identify the substances 'A' and 'B'. (1979)

2. A compound (X) containing C, H and O is unreactive towards sodium. It does not add bromine. It also does not react with Schiff's reagent. On refluxing with an excess of hydriodic acid, (X) yields only one organic product (Y). On hydrolysis, (Y) yields a new compound (Z) which can be converted into (Y) by reaction with red phosphorus and iodine. The compound (Z) on oxidation with potassium permanganate gives a carboxylic acid. The equivalent weight of this acid is 60. What are the compounds (X), (Y) and (Z)? Write chemical equations leading to the conversion of (X) to (Y). (1981 - 3 Marks)

3. Outline the reaction sequence for the conversion of

(i) 1-propanol from 2-propanol (in three steps)

(1982 - 1 Mark)

(ii) ethyl alcohol to vinyl acetate. (in not more than 6 steps)

(1986 - 3 Marks)

(iii) phenol to acetophenone (1989 - 1½ Marks)

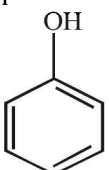
(iv)  → Aspirin (2003 - 2 Marks)

4. State with balanced equations what happens when :

(i) acetic anhydride reacts with phenol in presence of a base. (1982 - 1 Mark)

(ii) Ethylene glycol is obtained by the reaction of ethylene with potassium permanganate. (1991 - 1 Mark)

5. Give reasons for the following :

(i) Sodium metal can be used for drying diethyl ether but not ethanol. (1982 - 1 Mark)

(ii) Phenol is an acid but it does not react with sodium bicarbonate. (1987 - 1 Mark)

(iii) Acid catalysed dehydration of *t*-butanol is faster than that of *n*-butanol. (1998 - 2 Marks)

6. An alcohol A, when heated with conc.  $H_2SO_4$  gives an alkene B. When B is bubbled through bromine water and the product obtained is dehydrohalogenated with excess of sodamide, a new compound C is obtained. The compound C gives D when treated with warm dilute  $H_2SO_4$  in presence of  $HgSO_4$ . D can also be obtained either by oxidizing A with  $KMnO_4$  or from acetic acid through its calcium salt. Identify A, B, C and D. (1983 - 4 Marks)

7. A compound of molecular formula  $C_7H_8O$  is insoluble in water and dilute sodium bicarbonate but dissolves in dilute aqueous sodium hydroxide. On treatment with bromine water, it readily gives a precipitate of  $C_7H_5OBr_3$ . Write down the structure of the compound. (1985 - 2 Marks)

8. Give a chemical test/suggest a reagent to distinguish between methanol and ethanol. (1985 - 1 Mark)

9. Complete the following with appropriate structures :

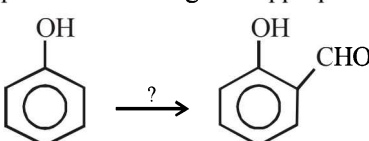
(i)  (1986 - 1 Mark)

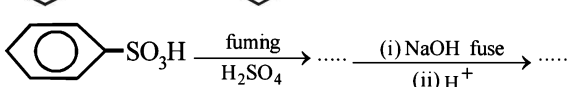
(ii) 

10. Compound 'X' (molecular formula,  $C_5H_8O$ ) does not react appreciably with Lucas reagent at room temperature but gives a precipitate with ammonical silver nitrate. With excess of  $MeMgBr$ , 0.42 g of 'X' gives 224 ml of  $CH_4$  at STP. Treatment of 'X' with  $H_2$  in presence of Pt catalyst followed by boiling with excess HI, gives *n*-pentane. Suggest structure for 'X' and write the equation involved. (1992 - 1 Mark)

(1992 - 5 Marks)

11. When *t*-butanol and *n*-butanol are separately treated with a few drops of dilute  $KMnO_4$ , in one case only the purple colour disappears and a brown precipitate is formed. Which of the two alcohols gives the above reaction and what is the brown precipitate? (1994 - 2 Marks)

12. When phenol is reacted with  $CHCl_3$  and NaOH followed by acidification, salicylaldehyde is obtained. Which of the following species are involved in the above mentioned reaction as intermediates? (1995 - 2 Marks)

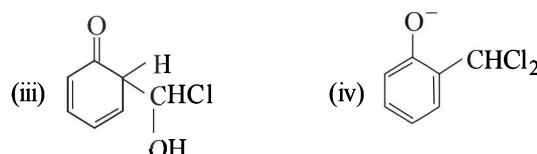

13. 3,3-Dimethylbutan-2-ol loses a molecule of water in the presence of concentrated sulphuric acid to give tetramethylethylene as a major product. Suggest a suitable mechanism. (1996 - 2 Marks)

14. A compound D ( $C_8H_{10}O$ ) upon treatment with alkaline solution of iodine gives a yellow precipitate. The filtrate on acidification gives a white solid E ( $C_7H_6O_2$ ). Write the structures of D and E and explain the formation of E. (1996 - 2 Marks)

15. An optically active alcohol A ( $C_6H_{10}O$ ) absorbs two moles of hydrogen per mole of A upon catalytic hydrogenation and gives a product B. The compound B is resistant to oxidation by  $CrO_3$  and does not show any optical activity. Deduce the structures of A and B. (1996 - 2 Marks)

16. Predict the structures of the intermediates/products in the following reaction sequence :

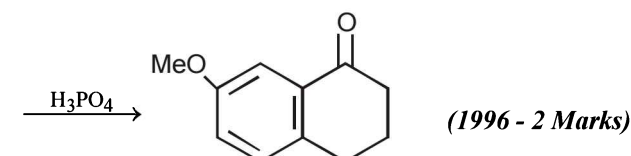
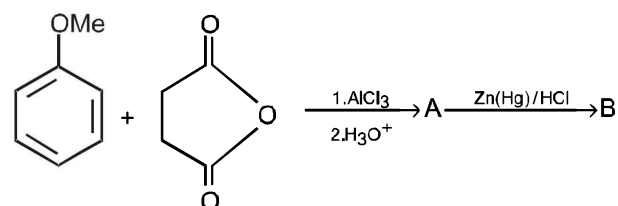

17. 2, 2-Dimethyloxirane can be cleaved by acid ( $H^+$ ). Write mechanism. (1997 - 2 Marks)

18. Which of the following is the correct method for synthesising methyl-t-butyl ether and why?



19. Write the intermediate steps for each of the following reaction.

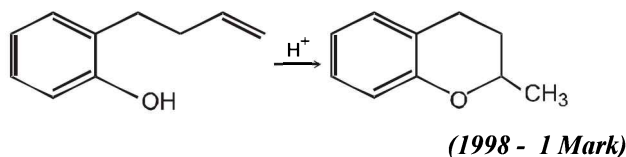

20. Explain briefly the formation of the products giving the structures of the intermediates. (1999 - 3 Marks)

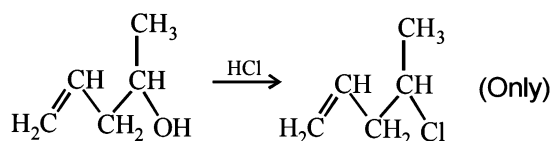
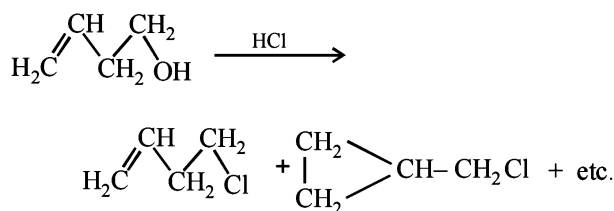

21. A biologically active compound, bombykol ( $C_{16}H_{30}O$ ) is obtained from a natural source. The structure of the compound is determined by the following reactions.

(2002 - 5 Marks)

(a) On hydrogenation, bombykol gives a compound A,  $C_{16}H_{34}O$ , which reacts with acetic anhydride to give an ester;

(b) Bombykol also reacts with acetic anhydride to give another ester, which on oxidative ozonolysis ( $O_3/H_2O_2$ ) gives a mixture of butanoic acid, oxalic acid and 10-acetoxydecanoic acid.

Determine the number of double bonds in bombykol. Write the structures of compound A and bombykol. How many geometrical isomers are possible for bombykol?

22. An organic compound (P) of molecular formula  $C_5H_{10}O$  is treated with dil.  $H_2SO_4$  to give two compounds (Q) and (R) both of which respond iodoform test. The rate of reaction of (P) with dil.  $H_2SO_4$  is  $10^{10}$  faster than the reaction of ethylene with dil.  $H_2SO_4$ . Identify the organic compounds, (P), (Q) and (R) and explain the extra reactivity of (P).

(2004 - 4 Marks)

23. Identify (X) and (Y) in the following reaction sequence.

(2005 - 2 Marks)

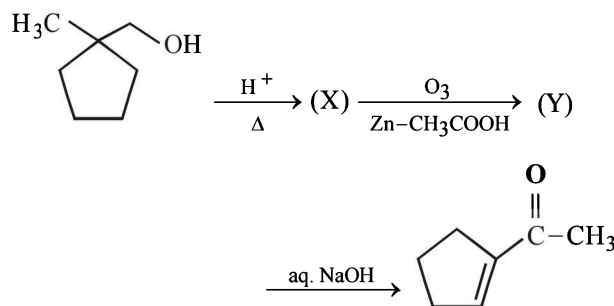

## F Match the Following

Following question has matching lists. The codes for the lists have choices (a), (b), (c) and (d) out of which ONLY ONE is correct.

1. Match the chemical conversions in List I with the appropriate reagents in List II and select the correct answer using the code given below the lists : (JEE Adv. 2013)

### List I

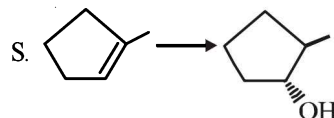
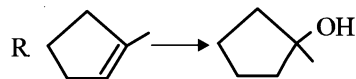
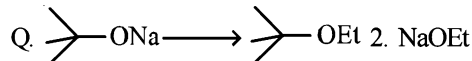
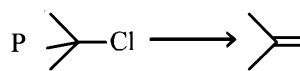

### List II

1. (i)  $Hg(OAc)_2$ ; (ii)  $NaBH_4$

2.  $NaOEt$

3.  $Et-Br$

4. (i)  $BH_3$ ; (ii)  $H_2O_2/NaOH$

### Codes :

	P	Q	R	S
(a)	2	3	1	4
(b)	3	2	1	4
(c)	2	3	4	1
(d)	3	2	4	1

## G Comprehension Based Questions

### PASSAGE-I

Riemer-Tiemann reaction introduces an aldehyde group, on to the aromatic ring of phenol, ortho to the hydroxyl group. This reaction involves electrophilic aromatic substitution. This is a general method for the synthesis of substituted salicylaldehyde as depicted below.

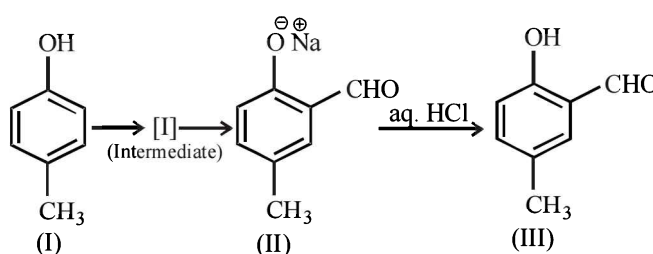

1. Which one of the following reagents is used in the above reaction? (2007)  
 (a) aq. NaOH + CH<sub>3</sub>Cl (b) aq. NaOH + CH<sub>2</sub>Cl<sub>2</sub>  
 (c) aq. NaOH + CHCl<sub>3</sub> (d) aq. NaOH + CCl<sub>4</sub>
2. The electrophile in the reaction is (2007)  
 (a) :CHCl (b) <sup>+</sup>CHCl<sub>2</sub>  
 (c) :CCl<sub>2</sub> (d) CCl<sub>3</sub>
3. The structure of the intermediate I is (2007)

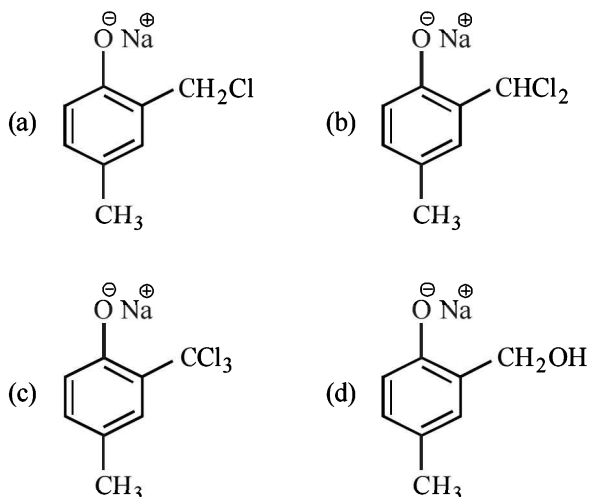

### PASSAGE-2

A tertiary alcohol H upon acid catalysed dehydration gives a product I. Ozonolysis of I leads to compounds J and K. Compound J upon reaction with KOH gives benzyl alcohol and compound L, whereas K on reaction with KOH gives only M.

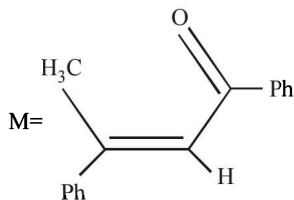

4. Compound H is formed by the reaction of (2008)

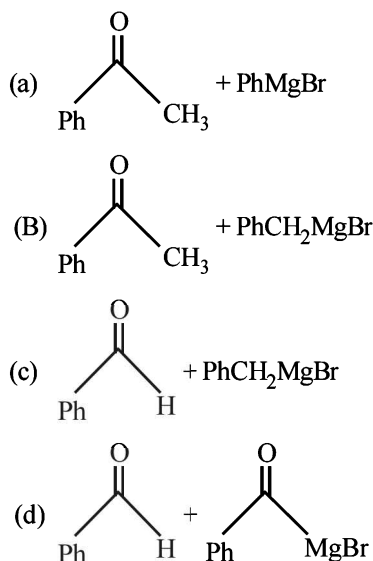

5. The structure of compound I is (2008)

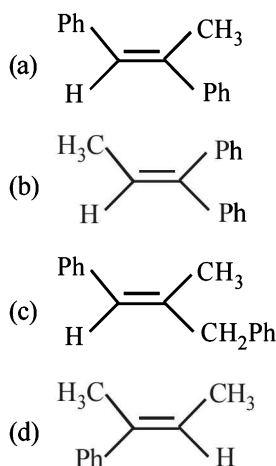

6. The structure of compounds J, K and L respectively, are – (2008)  
 (a) PhCOCH<sub>3</sub>, PhCH<sub>2</sub>COCH<sub>3</sub> and PhCH<sub>2</sub>COO<sup>-</sup>K<sup>+</sup>  
 (b) PhCHO, PhCH<sub>2</sub>CHO and PhCOO<sup>-</sup>K<sup>+</sup>  
 (c) PhCOCH<sub>3</sub>, PhCH<sub>2</sub>CHO and CH<sub>3</sub>COO<sup>-</sup>K<sup>+</sup>  
 (d) PhCHO, PhCOCH<sub>3</sub> and PhCOO<sup>-</sup>K<sup>+</sup>

### H Assertion & Reason Type Questions

1. Read the following statement and explanation and answer as per the options given below : (1988 - 2 Marks)

**Statement (S)** : Solubility of *n*-alcohols in water decreases with increase in molecular weight.

**Explanation (E)** : The relative proportion of the hydrocarbon part in alcohols increases with increasing molecular weight which permits enhanced hydrogen bonding with water.

- (a) Both (S) and (E) are correct and (E) is the correct explanation of (S).  
 (b) Both (S) and (E) are correct but (E) is not the correct explanation of (S).  
 (c) (S) is correct but (E) is wrong.  
 (d) (S) is wrong but (E) is correct.

### I Integer Value Correct Type

1. The number of resonance structures for N is (JEE Adv. 2015)

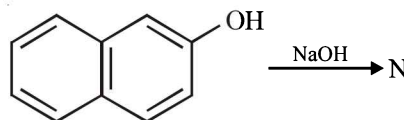

2. The number of hydroxyl group(s) in Q is (JEE Adv. 2015)

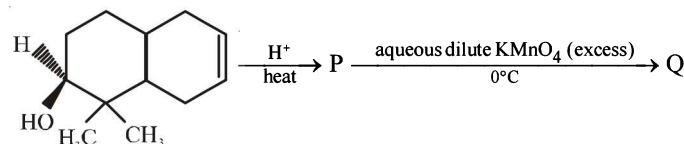

## Section-B

## JEE Main / AIEEE

1. During dehydration of alcohols to alkenes by heating with conc.  $\text{H}_2\text{SO}_4$  the initiation step is [2003]  
 (a) formation of carbocation  
 (b) elimination of water  
 (c) formation of an ester  
 (d) protonation of alcohol molecule
2. Among the following compounds which can be dehydrated very easily is [2004]

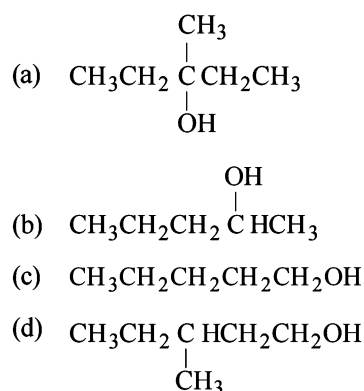

3. The best reagent to convert pent-3-en-2-ol into pent-3-in-2-one is [2005]  
 (a) Pyridinium chloro-chromate  
 (b) Chromic anhydride in glacial acetic acid  
 (c) A acidic dichromate  
 (d) Acidic permanganate
4. *p*-cresol reacts with chloroform in alkaline medium to give the compound A which adds hydrogen cyanide to form the compound B. The latter on acidic hydrolysis gives chiral carboxylic acid. The structure of the carboxylic acid is [2005]

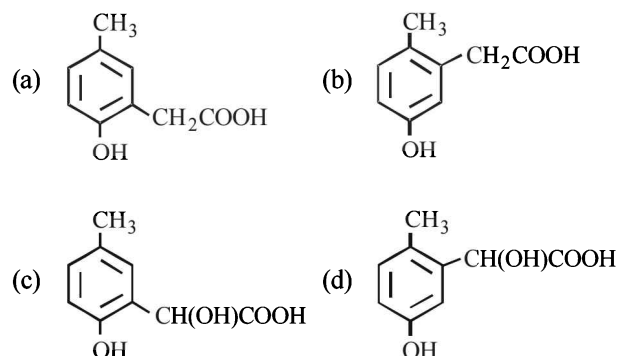

5.  $\text{HBr}$  reacts with  $\text{CH}_2=\text{CH}-\text{OCH}_3$  under anhydrous conditions at room temperature to give [2006]  
 (a)  $\text{BrCH}_2-\text{CH}_2-\text{OCH}_3$  (b)  $\text{H}_3\text{C}-\text{CHBr}-\text{OCH}_3$   
 (c)  $\text{CH}_3\text{CHO}$  and  $\text{CH}_3\text{Br}$  (d)  $\text{BrCH}_2\text{CHO}$  and  $\text{CH}_3\text{OH}$

6. Among the following the one that gives positive iodoform test upon reaction with  $\text{I}_2$  and  $\text{NaOH}$  is [2006]

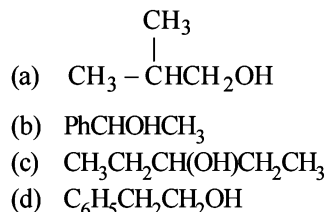

7. The structure of the compound that gives a tribromo derivative on treatment with bromine water is [2006]

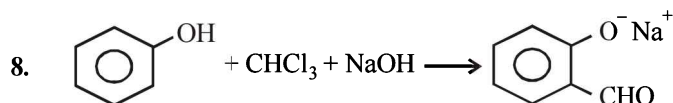
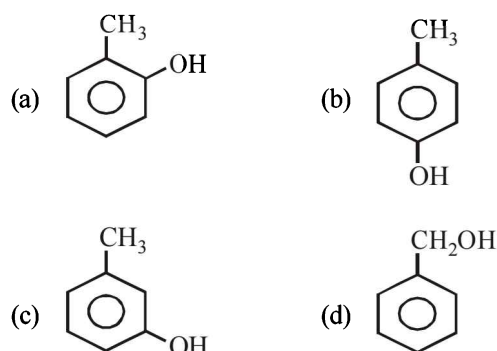

The electrophile involved in the above reaction is

- (a) trichloromethyl anion ( $\overset{\ominus}{\text{C}}\text{Cl}_3$ ) [2006]  
 (b) formyl cation ( $\overset{\oplus}{\text{C}}\text{HO}$ )  
 (c) dichloromethyl cation ( $\overset{\oplus}{\text{C}}\text{HCl}_2$ )  
 (d) dichlorocarbene ( $:\text{CCl}_2$ )
9. In the following sequence of reactions,  
 $\text{CH}_3\text{CH}_2\text{OH} \xrightarrow{\text{P}+\text{I}_2} \text{A} \xrightarrow[\text{ether}]{\text{Mg}} \text{B} \xrightarrow{\text{HCHO}} \text{C} \xrightarrow{\text{H}_2\text{O}} \text{D}$   
 the compound D is [2007]  
 (a) propanal (b) butanal  
 (c) *n*-butyl alcohol (d) *n*-propyl alcohol.
10. Phenol, when it first reacts with concentrated sulphuric acid and then with concentrated nitric acid, gives [2008]  
 (a) 2, 4, 6-trinitrobenzene  
 (b) *o*-nitrophenol  
 (c) *p*-nitrophenol  
 (d) nitrobenzene

11. The major product obtained on interaction of phenol with sodium hydroxide and carbon dioxide is [2009]

- (a) salicylaldehyde (b) salicylic acid  
(c) phthalic acid (d) benzoic acid

12. From amongst the following alcohols the one that would react fastest with conc. HCl and anhydrous ZnCl<sub>2</sub>, is [2010]

- (a) 2-Butanol (b) 2-Methylpropan-2-ol  
(c) 2-Methylpropanol (d) 1-Butanol

13. The main product of the following reaction is  
 $C_6H_5CH_2CH(OH)CH(CH_3)_2 \xrightarrow{\text{conc. } H_2SO_4} ?$  [2010]

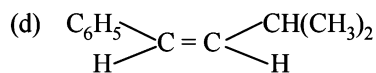
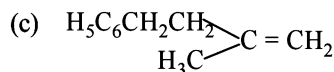
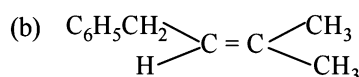
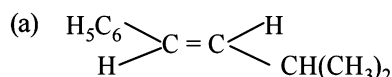

14. Phenol is heated with a solution of mixture of KBr and KBrO<sub>3</sub>. The major product obtained in the above reaction is:

[2011]

- (a) 2-Bromophenol (b) 3-Bromophenol  
(c) 4-Bromophenol (d) 2, 4, 6-Tribromophenol

15. Arrange the following compounds in order of decreasing acidity: [JEE M 2013]

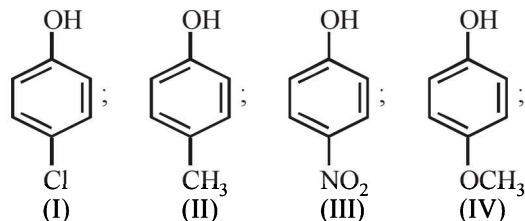

- (a) II > IV > I > III (b) I > II > III > IV  
(c) III > I > II > IV (d) IV > III > I > II

16. An unknown alcohol is treated with the "Lucas reagent" to determine whether the alcohol is primary, secondary or tertiary. Which alcohol reacts fastest and by what mechanism:

[JEE M 2013]

- (a) secondary alcohol by S<sub>N</sub>1  
(b) tertiary alcohol by S<sub>N</sub>1  
(c) secondary alcohol by S<sub>N</sub>2  
(d) tertiary alcohol by S<sub>N</sub>2

17. Sodium phenoxide when heated with CO<sub>2</sub> under pressure at 125°C yields a product which on acetylation produces C.

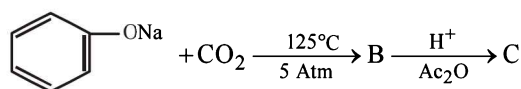

The major product C would be [JEE M 2014]

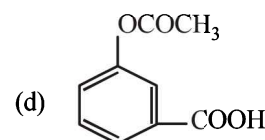
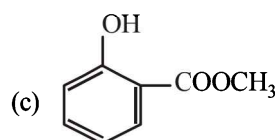
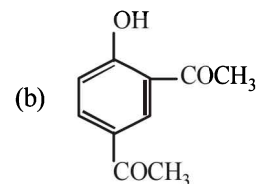
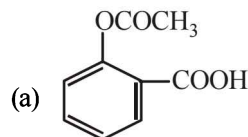

18. Thiol group is present in: [JEE M 2016]

- (a) Cysteine (b) Methionine  
(c) Cytosine (d) Cystine

19. The product of the reaction given below is: [JEE M 2016]

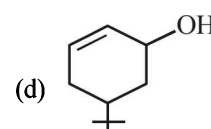
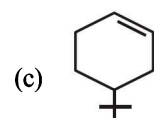
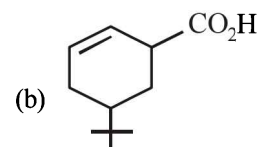
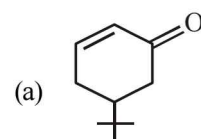
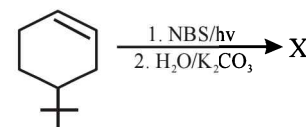

20. 2-chloro-2-methylpentane on reaction with sodium methoxide in methanol yields: [JEE M 2016]

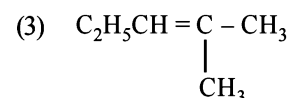
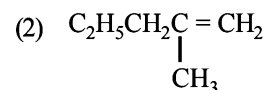
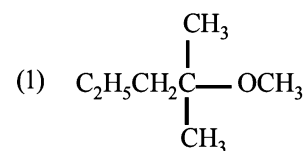

- (a) (3) only (b) (a) and (b)  
(c) All of these (d) (a) and (c)



# CHAPTER 20

# Aldehydes, Ketones and Carboxylic Acids

## Section-A JEE Advanced/ IIT-JEE

### A Fill in the Blanks

- Formic acid when heated with conc.  $\text{H}_2\text{SO}_4$  produces .....  
(1983 - 1 Mark)
- Fehling's solution 'A' consists of an aqueous solution of copper sulphate, while Fehling's solution 'B' consists of an alkaline solution of.....  
(1990 - 1 Mark)
- The structure of the intermediate product, formed by the oxidation of toluene with  $\text{CrO}_3$  and acetic anhydride, whose hydrolysis gives benzaldehyde is .....  
(1992 - 1 Mark)
- The structure of the enol form of  $\text{CH}_3\text{-CO-CH}_2\text{-CO-CH}_3$  with intramolecular hydrogen bonding is .....  
(1993 - 1 Mark)
- The Cannizzaro reaction is not given by (1983 - 1 Mark)  
(a) trimethylacetaldehyde (b) acetaldehyde  
(c) benzaldehyde (d) formaldehyde
- The compound that will not give iodoform on treatment with alkali and iodine is : (1985 - 1 Mark)  
(a) acetone (b) ethanol  
(c) diethyl ketone (d) isopropyl alcohol
- Polarisation of electrons in acrolein may be written as (1988 - 1 Mark)  
(a)  $\overset{\delta^-}{\text{CH}_2}=\overset{\delta^+}{\text{CH}}-\overset{\delta^+}{\text{C}}=\overset{\delta^-}{\text{O}}$  (b)  $\overset{\delta^-}{\text{CH}_2}=\overset{\delta^-}{\text{CH}}-\overset{\delta^+}{\text{C}}=\overset{\delta^+}{\text{O}}$   
(c)  $\overset{\delta^-}{\text{CH}_2}=\overset{\delta^+}{\text{CH}}-\overset{\delta^+}{\text{C}}=\overset{\delta^-}{\text{O}}$  (d)  $\overset{\delta^+}{\text{CH}_2}=\overset{\delta^-}{\text{CH}}-\overset{\delta^-}{\text{C}}=\overset{\delta^+}{\text{O}}$

### B True / False

- Benzaldehyde undergoes aldol condensation in an alkaline medium. (1982 - 1 Mark)
- Hydrolysis of an ester in presence of a dilute acid is known as saponification. (1983 - 1 Mark)
- The yield of ketone when a secondary alcohol is oxidized is more than the yield of aldehyde when a primary alcohol is oxidized. (1983 - 1 Mark)
- The reaction of methyl magnesium iodide with acetone followed by hydrolysis gives secondary butanol. (1987 - 1 Mark)
- The boiling point of propionic acid is less than that of *n*-butyl alcohol, an alcohol of comparable molecular weight. (1991 - 1 Mark)
- The enolic form of acetone contains (1990 - 1 Mark)  
(a) 9 sigma bonds, 1 pi-bond and 2 lone pairs  
(b) 8 sigma bonds, 2 pi-bonds and 2 lone pairs  
(c) 10 sigma bonds, 1 pi-bond and 1 lone pair  
(d) 9 sigma bonds, 2 pi-bonds and 1 lone pair
- m*-Chlorobenzaldehyde on reaction with conc. KOH at room temperature gives (1991 - 1 Mark)  
(a) potassium *m*-chlorobenzoate and *m*-hydroxybenzaldehyde  
(b) *m*-hydroxybenzaldehyde and *m*-chlorobenzyl alcohol  
(c) *m*-chlorobenzyl alcohol and *m*-hydroxybenzyl alcohol  
(d) potassium *m*-chlorobenzoate and *m*-chlorobenzyl alcohol
- Hydrogenation of benzoyl chloride in the presence of Pd on  $\text{BaSO}_4$  gives (1992 - 1 Mark)  
(a) Benzyl alcohol (b) Benzaldehyde  
(c) Benzoic acid (d) Phenol

### C MCQs with One Correct Answer

- The reagent with which both acetaldehyde and acetone react easily is (1981 - 1 Mark)  
(a) Fehling's reagent (b) Grignard reagent  
(c) Schiff's reagent (d) Tollen's reagent
- When acetaldehyde is heated with Fehling's solution it gives a precipitate of (1983 - 1 Mark)  
(a) Cu (b) CuO  
(c)  $\text{Cu}_2\text{O}$  (d)  $\text{Cu} + \text{Cu}_2\text{O} + \text{CuO}$
- The organic product formed in the reaction (1995S)  
$$\text{C}_6\text{H}_5\text{COOH} \xrightarrow[\text{II } \text{H}_3\text{O}^+]{\text{I LiAlH}_4}$$
  
(a)  $\text{C}_6\text{H}_5\text{CH}_2\text{OH}$  (b)  $\text{C}_6\text{H}_5\text{COOH} + \text{CH}_4$   
(c)  $\text{C}_6\text{H}_5\text{CH}_3 + \text{CH}_3\text{OH}$  (d)  $\text{C}_6\text{H}_5\text{CH}_3 + \text{CH}_4$
- The reaction products of  $\text{C}_6\text{H}_5\text{OCH}_3 + \text{HI} \xrightarrow{\Delta}$  is : (1995S)  
(a)  $\text{C}_6\text{H}_5\text{OH} + \text{CH}_3\text{I}$  (b)  $\text{C}_6\text{H}_5\text{I} + \text{CH}_3\text{OH}$   
(c)  $\text{C}_6\text{H}_5\text{CH}_3 + \text{HOI}$  (d)  $\text{C}_6\text{H}_6 + \text{CH}_3\text{OH}$

11. In the Cannizzaro reaction given below, (1996 - 1 Mark)

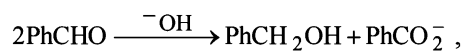

the slowest step is

- (a) the attack of  $^-\text{OH}$  at the carbonyl group,  
 (b) the transfer of hydride to the carbonyl group,  
 (c) the abstraction of proton from the carboxylic acid,  
 (d) the deprotonation of  $\text{PhCH}_2\text{OH}$ .
12. When propionic acid is treated with aqueous sodium bicarbonate,  $\text{CO}_2$  is liberated. The 'C' of  $\text{CO}_2$  comes from (1999 - 2 Marks)
- (a) methyl group (b) carboxylic acid group  
 (c) methylene group (d) bicarbonate
13. The enol form of acetone, after treatment with  $\text{D}_2\text{O}$ , gives. (1999 - 2 Marks)

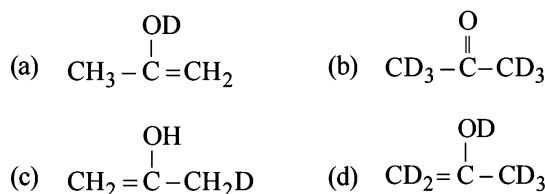

14. Which one of the following will most readily be dehydrated in acidic condition? (2000S)

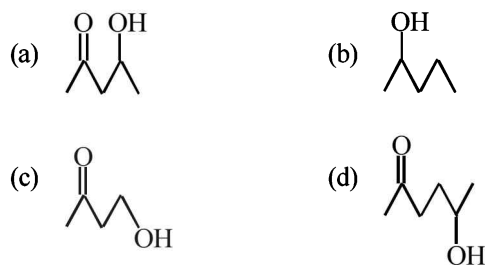

15. Benzoyl chloride is prepared from benzoic acid by (2000S)



16. The appropriate reagent for the following transformation is (2000S)

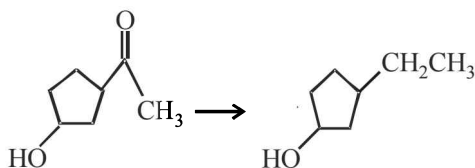

17. A mixture of benzaldehyde and formaldehyde on heating with aqueous  $\text{NaOH}$  solution gives (2001S)

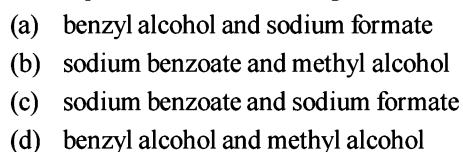

18. The product of acid hydrolysis of P and Q can be distinguished by (2003S)

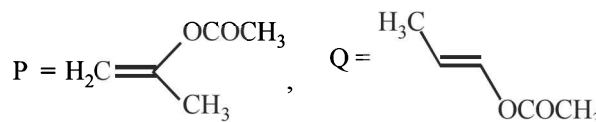

- (a) Lucas Reagent (b) 2,4-DNP  
 (c) Fehling's Solution (d)  $\text{NaHSO}_3$

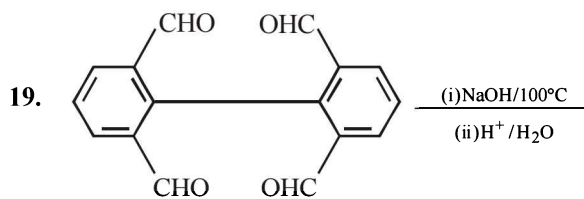

Major product is : (2003S)

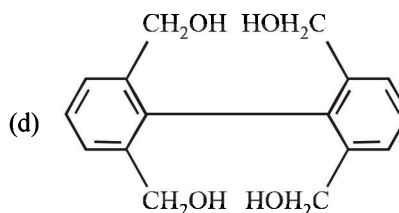
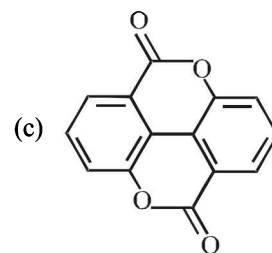
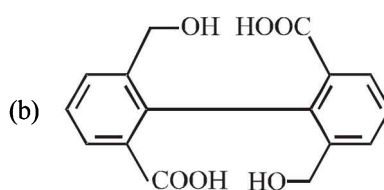
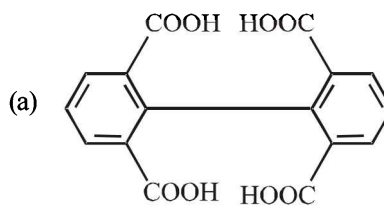

20. Ethyl ester  $\xrightarrow[\text{excess}]{\text{CH}_3\text{MgBr}}$  P. The product P will be (2003S)

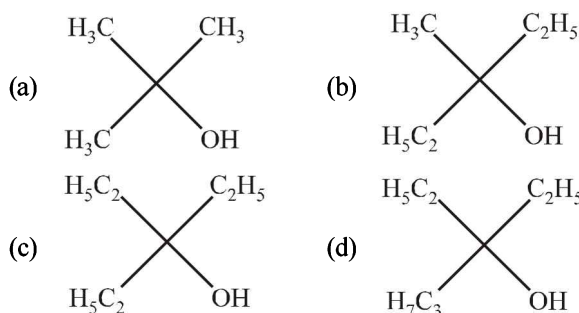

21. An enantiomerically pure acid is treated with a racemic mixture of an alcohol having one chiral carbon. The ester formed will be (2003S)

- (a) Optically active mixture (b) Pure enantiomer  
(c) Meso compound (d) Racemic mixture

22. The correct order of reactivity of PhMgBr with (2004S)

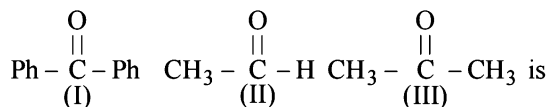

- (a) (I) > (II) > (III) (b) (III) > (II) > (I)  
(c) (II) > (III) > (I) (d) (I) > (III) > (II)

23. How will you convert butan-2-one to propanoic acid? (2005S)

- (a) Tollen's reagent (b) Fehling's solution  
(c) NaOH/I<sub>2</sub>/H<sup>+</sup> (d) NaOH/NaI/H<sup>+</sup>

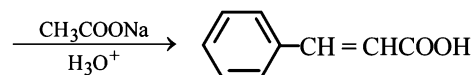
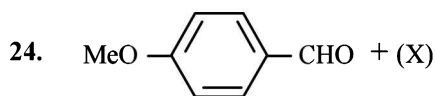

The compound (X) is (2005S)

- (a) CH<sub>3</sub>COOH (b) BrCH<sub>2</sub>-COOH  
(c) (CH<sub>3</sub>CO)<sub>2</sub>O (d) CHO-COOH

25. 4-Methylbenzenesulphonic acid reacts with sodium acetate to give (2005S)

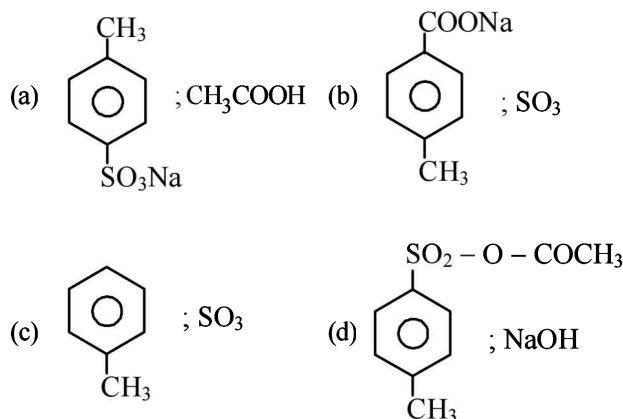

26. In the following reaction sequence, the correct structures of E, F and G are

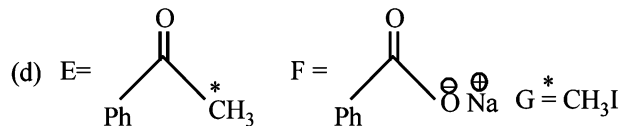
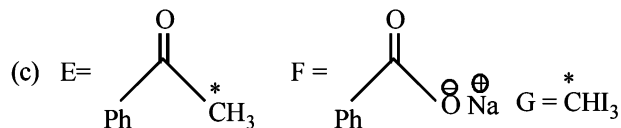
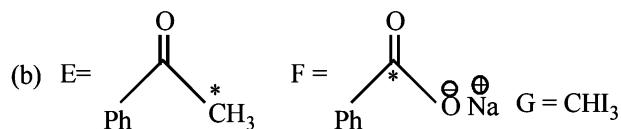
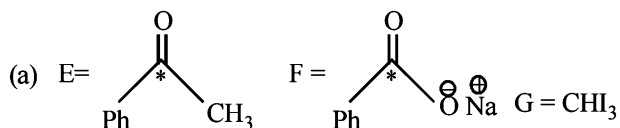
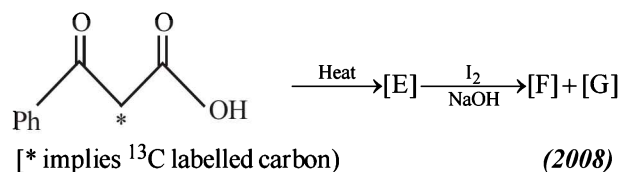

27. The correct acidity order of the following is (2009S)

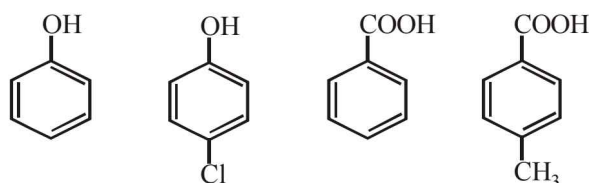

- (a) (III) > (IV) > (II) > (I) (b) (IV) > (III) > (I) > (II)  
(c) (III) > (II) > (I) > (IV) (d) (II) > (III) > (IV) > (I)

28. In the reaction

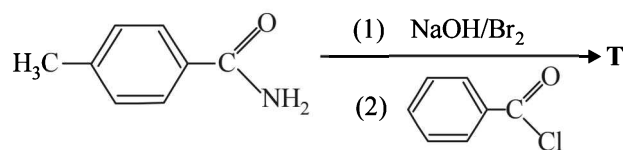

the structure of the product T is: (2010)

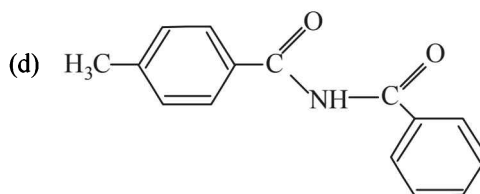
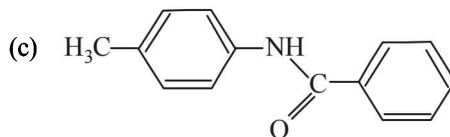
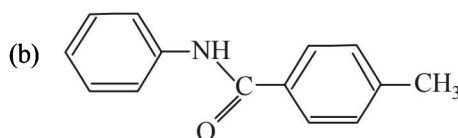
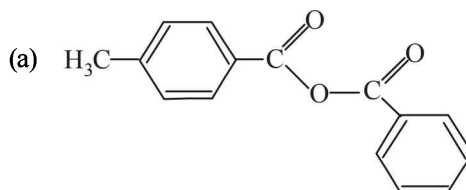

29. The compounds P, Q and S

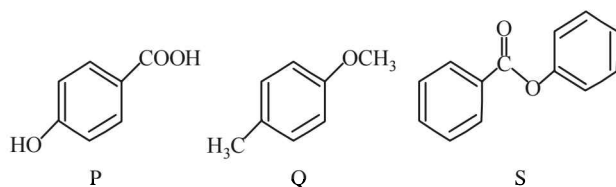

were separately subjected to nitration using  $\text{HNO}_3/\text{H}_2\text{SO}_4$  mixture. The major product formed in each case respectively, is: (2010)

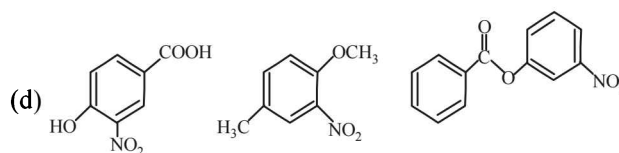
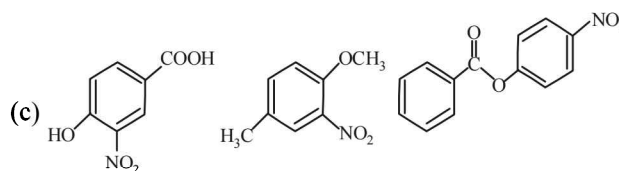
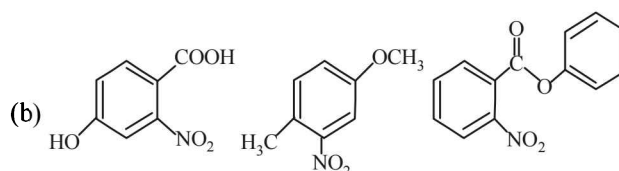
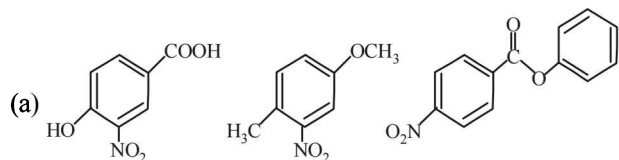

30. The major product of the following reaction is (2011)

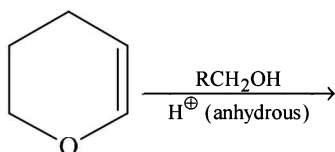

- (a) a hemiacetal                      (b) an acetal  
(c) an ether                              (d) an ester

31. The carboxyl functional group ( $-\text{COOH}$ ) is present in (2012)

- (a) picric acid                      (b) barbituric acid  
(c) ascorbic acid                      (d) aspirin

32. The major product H of the given reaction sequence is

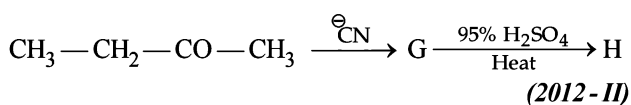

- (a)  $\text{CH}_3-\text{CH}=\underset{\text{CH}_3}{\text{C}}-\text{COOH}$

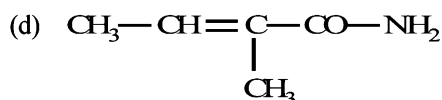
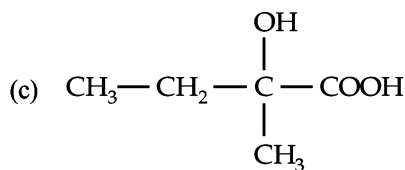
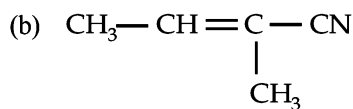

33. The compound that undergoes decarboxylation most readily under mild condition is (2012)

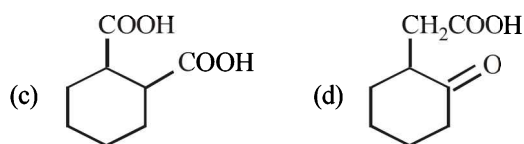
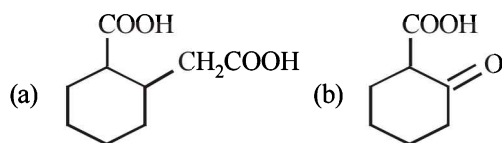

34. The compound that does NOT liberate  $\text{CO}_2$ , on treatment with aqueous sodium bicarbonate solution, is (JEE Adv. 2013)

- (a) Benzoic acid                      (b) Benzenesulphonic acid  
(c) Salicylic acid                      (d) Carboic acid (Phenol)

35. The major product in the following reaction is

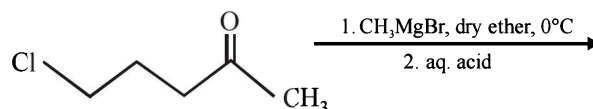

(JEE Adv. 2014)

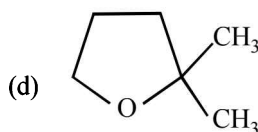
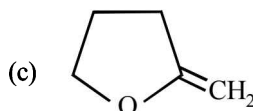
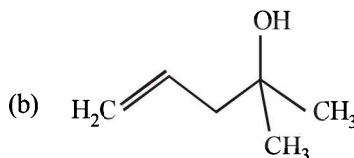
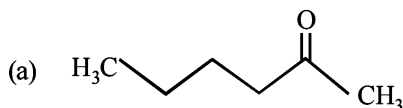

36. The correct order of acidity for the following compounds is

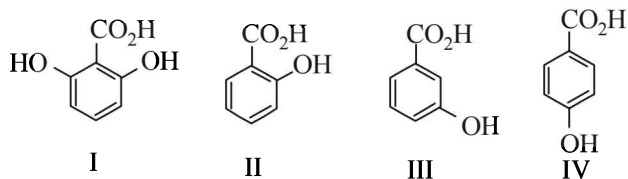

(JEE Adv. 2016)

- (a) I > II > III > IV      (b) III > I > II > IV  
(c) III > IV > II > I      (d) I > III > IV > II

37. The major product of the following reaction sequence is

(JEE Adv. 2016)

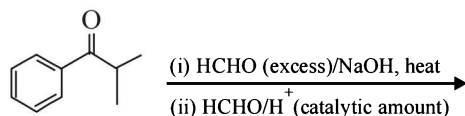

- (a)      (b)
- (c)      (d)

## D MCQs with One or More Than One Correct

- Base catalysed aldol condensation occurs with : (1984 - 1 Mark)
  - propionaldehyde
  - benzaldehyde
  - 2-methylpropionaldehyde
  - 2,2-dimethylpropionaldehyde
- Which of the following compounds will give a yellow precipitate with iodine and alkali? (1984 - 1 Mark)
  - 2-Hydroxypropane
  - acetophenone
  - methyl acetate
  - acetamide
- Which of the following compounds will react with ethanolic KCN? (1984 - 1 Mark)
  - ethyl chloride
  - acetyl chloride
  - chlorobenzene
  - benzaldehyde
- Keto-enol tautomerism is observed in (1988 - 1 Mark)
  - $\text{H}_5\text{C}_6-\text{C}(=\text{O})-\text{H}$
  - $\text{H}_5\text{C}_6-\text{C}(=\text{O})-\text{CH}_3$
  - $\text{H}_5\text{C}_6-\text{C}(=\text{O})-\text{C}_6\text{H}_5$
  - $\text{H}_5\text{C}_6-\text{C}(=\text{O})-\text{CH}_2-\text{CH}_3$
- Which of the following are examples of aldol condensation? (1989 - 1 Mark)
  - $2\text{CH}_3\text{CHO} \xrightarrow{\text{dil. NaOH}} \text{CH}_3\text{CHOHCH}_2\text{CHO}$
  - $2\text{CH}_3\text{COCH}_3 \xrightarrow{\text{dil. NaOH}} \text{CH}_3\text{COH}(\text{CH}_3)\text{CH}_2\text{COCH}_3$
  - $2\text{HCHO} \xrightarrow{\text{dil. NaOH}} \text{CH}_3\text{OH}$
  - $\text{C}_6\text{H}_5\text{CHO} + \text{HCHO} \xrightarrow{\text{dil. NaOH}} \text{C}_6\text{H}_5\text{CH}_2\text{OH}$

6. A new carbon-carbon bond formation is possible in (1998 - 2 Marks)

- Cannizzaro reaction
- Friedel-Craft alkylation
- Clemmensen reduction
- Reimer-Tiemann reaction

7. Which of the following will react with water? (1998 - 2 Marks)

- $\text{CHCl}_3$
- $\text{Cl}_3\text{CCHO}$
- $\text{CCl}_4$
- $\text{ClCH}_2\text{CH}_2\text{Cl}$

8. Which of the following will undergo aldol condensation? (1998 - 2 Marks)

- acetaldehyde
- propanaldehyde
- benzaldehyde
- trideuteroacetaldehyde

9. Which of the following reactants on reaction with conc. NaOH followed by acidification gives following lactone as the product? (2006 - 5M, -1)

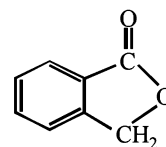

- 
- 
- 
- 

10. +  $\text{Cl}-\text{CH}_2\text{CH}_2\text{CH}_3$

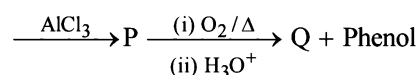

The major products P and Q are (2006 - 5M, -1)

- and  $\text{CH}_3\text{CH}_2\text{CHO}$
- and  $\text{CH}_3\text{COCH}_3$
- and  $\text{CH}_3\text{COCH}_3$
- and  $\text{CH}_3\text{CH}_2\text{CHO}$

11. The smallest ketone and its next homologue are reacted with  $\text{NH}_2\text{OH}$  to form oxime (2006 - 5M, -1)

- Two different oximes are formed
- Three different oximes are formed
- Two oximes formed are optically active
- All oximes formed are optically active

12. Identify the binary mixture(s) that can be separated into individual compounds, by differential extraction as shown in the given scheme. (2012)

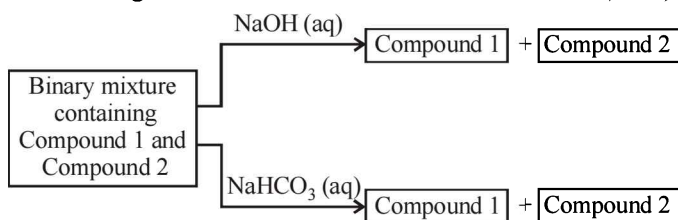

- (a) C<sub>6</sub>H<sub>5</sub>OH and C<sub>6</sub>H<sub>5</sub>COOH  
 (b) C<sub>6</sub>H<sub>5</sub>COOH and C<sub>6</sub>H<sub>5</sub>CH<sub>2</sub>OH  
 (c) C<sub>6</sub>H<sub>5</sub>CH<sub>2</sub>OH and C<sub>6</sub>H<sub>5</sub>OH  
 (d) C<sub>6</sub>H<sub>5</sub>CH<sub>2</sub>OH and C<sub>6</sub>H<sub>5</sub>CH<sub>2</sub>COOH
13. With reference to the scheme given below, which of the given statement(s) about T, U, V and W is (are) correct ?

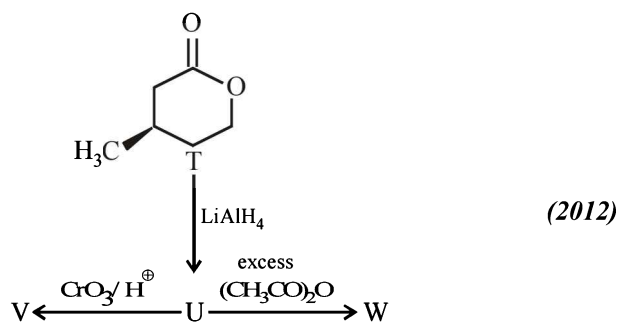

- (a) T is soluble in hot aqueous NaOH  
 (b) U is optically active  
 (c) Molecular formula of W is C<sub>10</sub>H<sub>18</sub>O<sub>4</sub>  
 (d) V gives effervescence on treatment with aqueous NaHCO<sub>3</sub>.
14. In the following reaction, the product(s) formed is(are) (JEE Adv. 2013)

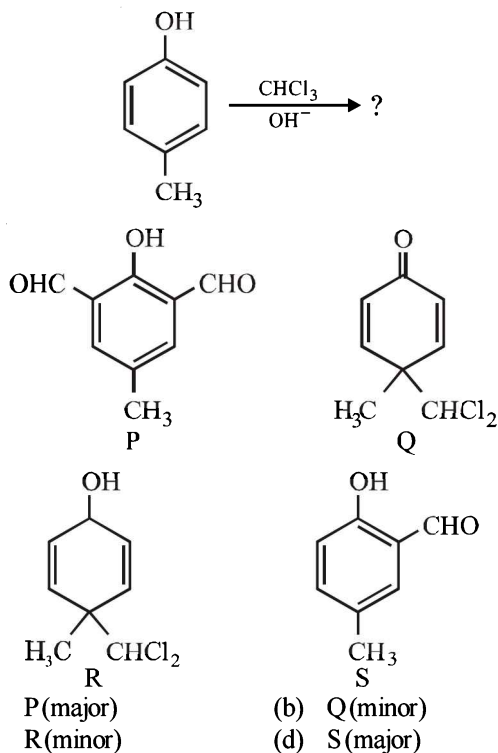

15. After completion of the reactions (I and II), the organic compound(s) in the reaction mixtures is(are) (JEE Adv. 2013)

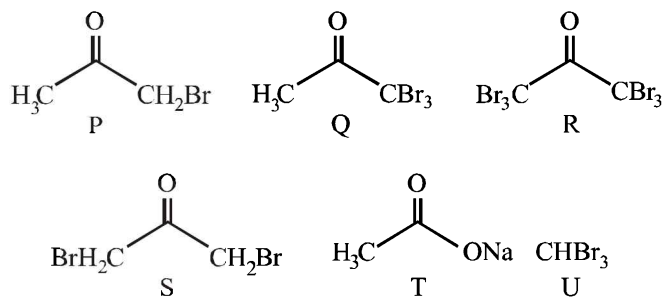
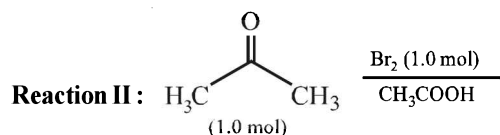
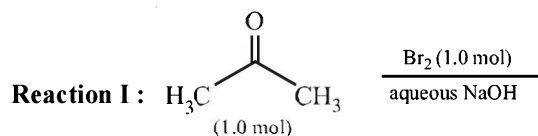

- (a) Reaction I : P and Reaction II : P  
 (b) Reaction I : U, acetone and Reaction II : Q, acetone  
 (c) Reaction I : T, U, acetone and Reaction II : P  
 (d) Reaction I : R, acetone and Reaction II : S, acetone
16. The major product of the following reaction is (JEE Adv. 2015)

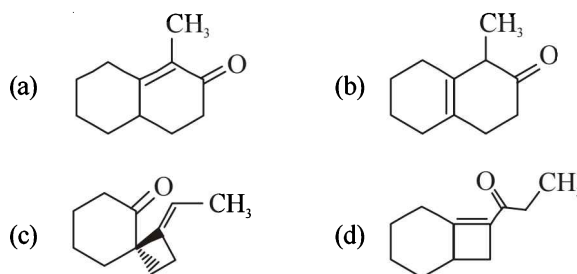
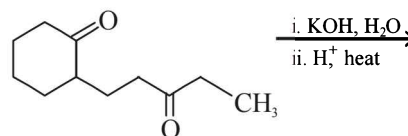

17. Positive Tollen's test is observed for (JEE Adv. 2016)

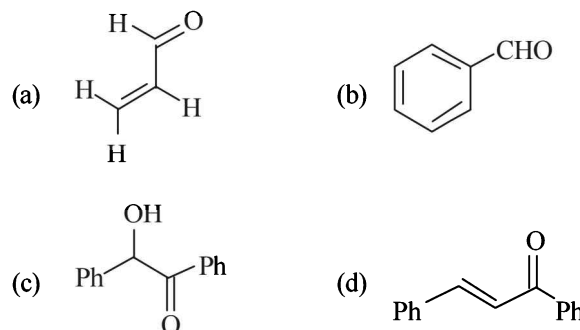

18. The correct statement(s) about the following reaction sequence is(are) (JEE Adv. 2016)

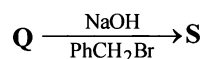
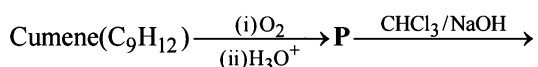

- (a) R is steam Volatile  
 (b) Q gives dark violet coloration with 1% aqueous FeCl<sub>3</sub> solution  
 (c) S gives yellow precipitate with 2, 4-dinitrophenylhydrazine  
 (d) S gives dark violet coloration with 1% aqueous FeCl<sub>3</sub> solution
19. Reagent(s) which can be used to bring about the following transformation is (are) (JEE Adv. 2016)

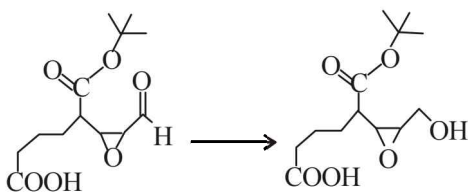

- (a) LiAlH<sub>4</sub> in (C<sub>2</sub>H<sub>5</sub>)<sub>2</sub>O      (b) BH<sub>3</sub> in THF  
 (c) NaBH<sub>4</sub> in C<sub>2</sub>H<sub>5</sub>OH      (d) Raney Ni/H<sub>2</sub> in THF

## E Subjective Problems

1. Write the structural formula of the main organic product formed when :

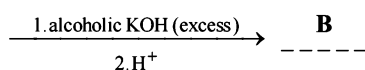
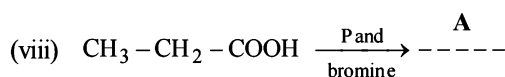
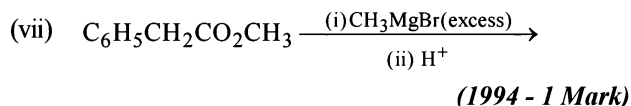
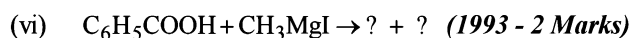
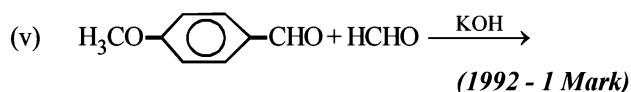
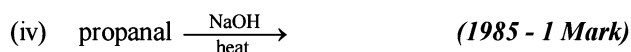
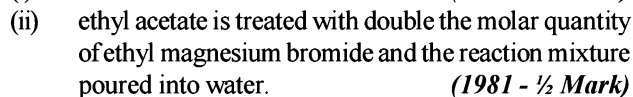
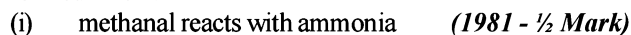

(1995 - 2 Marks)

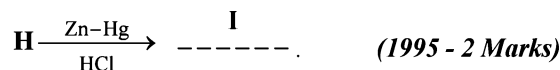
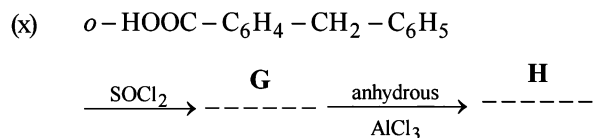
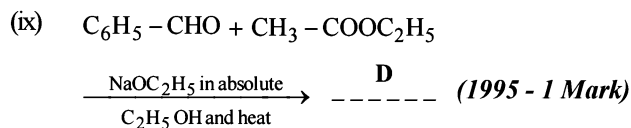

- (xi) Complete the following reaction with appropriate structure. (1996 - 1 Mark)

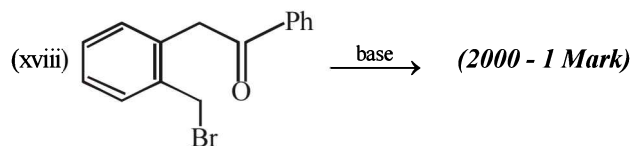
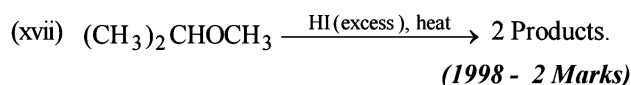
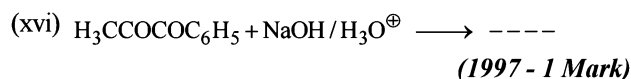
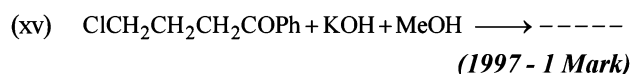
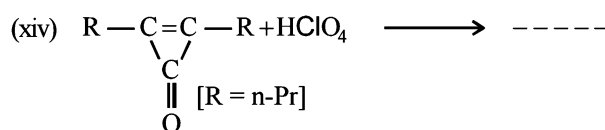
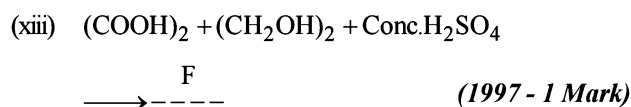
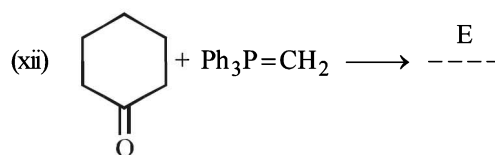
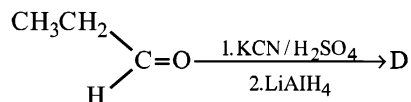

- (xix) Write the structures of the products A and B.

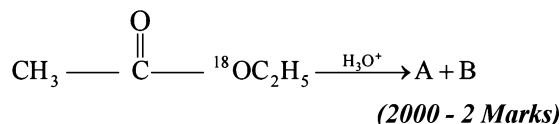

- (xx) Identify A, B, C and give their structures.

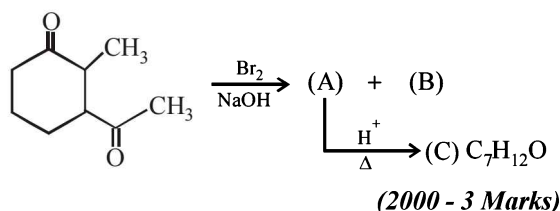

2. Write the chemical equation to show what happens when ethyl acetate is treated with sodium ethoxide in ethanol and the reaction mixture is acidified. (1981 - 2 Marks)
3. Outline the reaction sequence for the conversion of
- methanal to ethanal (the number of steps should not be more than three). (1981 - 2 Marks)
  - acetylene to acetone (1985 - 1 Mark)
  - acetic acid to tertiary-butyl alcohol. (1989 - 1½ Marks)
  - Ethanal to 2-hydroxy-3-butenic acid. (1990 - 2 Marks)
  - Ethanoic acid to a mixture of methanoic acid and diphenyl ketone. (1990 - 2 Marks)
  - Carry out the following transformation in not more than three steps. (1999 - 3 Marks)
- $$\text{CH}_3 - \text{CH}_2 - \text{C} \equiv \text{C} - \text{H} \rightarrow \text{CH}_3 - \text{CH}_2 - \text{CH}_2 - \overset{\text{O}}{\parallel}{\text{C}} - \text{CH}_3$$
4. Outline the accepted mechanism of the following reaction. Show the various steps including the charged intermediates. (1981 - 3 Marks)
- $$\text{C}_6\text{H}_6 + \text{CH}_3 - \overset{\text{O}}{\parallel}{\text{C}} - \text{Cl} \xrightarrow{\text{AlCl}_3} \text{C}_6\text{H}_5 - \overset{\text{O}}{\parallel}{\text{C}} - \text{CH}_3 + \text{HCl}$$
5. An alkene (A) on ozonolysis yields acetone and an aldehyde. The aldehyde is easily oxidized to an acid (B). When B is treated with bromine in presence of phosphorus, it yields a compound (C) which on hydrolysis gives a hydroxy acid (D). This acid can also be obtained from acetone by reaction with hydrogen cyanide followed by hydrolysis. Identify the compounds A, B, C and D. (1982 - 2 Marks)
6. Give reasons for the following :
- Acetic acid can be halogenated in the presence of red P and  $\text{Cl}_2$  but formic acid cannot be halogenated in the same way. (1983 - 1 Mark)
  - Formic acid is a stronger acid than acetic acid; (1985 - 1 Mark)
  - Suggest a reason for the large difference between the boiling points of butanol and butanal, although they have almost the same solubility in water. (1985 - 2 Marks)
  - Hydrazones of aldehydes and ketones are not prepared in highly acidic medium. (1986 - 1 Mark)
  - Iodoform is obtained by the reaction of acetone with hypoiodite but not with iodide ion. (1991 - 1 Mark)
  - In acylium ion, the structure  $\text{R} - \text{C} \equiv \text{O}^+$  is more stable than  $\text{R} - \text{C}^+ = \text{O}$ . (1994 - 1 Mark)
  - Although phenoxide ion has more number of resonating structures than benzoate ion, benzoic acid is a stronger acid than phenol. Why? (1997 - 2 Marks)
  - Explain why *o*-hydroxybenzaldehyde is a liquid at room temperature while *p*-hydroxybenzaldehyde is a high melting solid. (1999 - 2 Marks)
7. State the conditions under which the following preparation are carried out. Give the necessary equations which need not be balanced.
- Ethanol from acetylene (1983 - 1 Mark)
  - Acetic acid from methyl iodide (1983 - 1 Mark)
8. What happens when *p*-xylene is reacted with concentrated sulphuric acid and the resultant product is fused with KOH. (1984 - 2 Marks)
9. Write down the reactions involved in the preparation of the following using the reagents indicated against it in parenthesis :
- Propionic anhydride from propionaldehyde  $[\text{AgNO}_3/\text{NH}_4\text{OH}, \text{P}_2\text{O}_5]$ . (1984 - 2 Marks)
10. Give a chemical test/suggest a reagent to distinguish between acetaldehyde from acetone. (1987 - 1 Mark)
11. Arrange the following in increasing ease of hydrolysis  $\text{CH}_3\text{COOC}_2\text{H}_5, \text{CH}_3\text{COCl}, (\text{CH}_3\text{CO})_2\text{O}, \text{CH}_3\text{CONH}_2$ . (1986 - 1 Mark)
12. A white precipitate was formed slowly when silver nitrate was added to a compound (A) with molecular formula  $\text{C}_6\text{H}_{13}\text{Cl}$ . Compound (A) on treatment with hot alcoholic potassium hydroxide gave a mixture of two isomeric alkenes (B) and (C), having formula  $\text{C}_6\text{H}_{12}$ . The mixture of (B) and (C), on ozonolysis, furnished four compounds :
- $\text{CH}_3\text{CHO}$ ;
  - $\text{C}_2\text{H}_5\text{CHO}$ ;
  - $\text{CH}_3\text{COCH}_3$  and
  - $\text{H}_3\text{C} - \underset{\text{CH}_3}{\text{CH}} - \text{CHO}$
- What are the structures of (A), (B) and (C)?
13. A liquid (X), having a molecular formula  $\text{C}_6\text{H}_{12}\text{O}_2$  is hydrolysed with water in the presence of an acid to give a carboxylic acid (Y) and an alcohol (Z). Oxidation of (Z) with chromic acid gives (Y). What are the structures of (X), (Y) and (Z)? (1986 - 3 Marks)
14. Complete the following with appropriate structures :
- $(\text{CH}_3\text{CO})_2\text{O} \xrightarrow{\text{C}_2\text{H}_5\text{OH}} \text{CH}_3\text{COOH} + ?$  (1986 - 1 Mark)
  - $? \xrightarrow{\text{NaOH}} \text{C}_6\text{H}_5 - \text{CH} = \text{CH} - \text{CHO}$  (1986 - 1 Mark)
15. An unknown compound of carbon, hydrogen and oxygen contains 69.77% carbon and 11.63% hydrogen and has a molecular weight of 86. It does not reduce Fehling solution, but forms a bisulphite addition compound and gives a positive iodoform test. What are the possible structures for the unknown compound? (1987 - 5 Marks)
16. An organic compound (A) on treatment with acetic acid in the presence of sulphuric acid produces an ester (B), (A) on mild oxidation gives (C), (C) with 50% potassium hydroxide followed by acidification with dilute hydrochloric acid generates (A) and (D), (D) with phosphorus pentachloride followed by reaction with ammonia gives (E), (E) on dehydration produces hydrocyanic acid. Identify the compounds A, B, C, D and E. (1987 - 5 Marks)



17. Complete the following reactions :

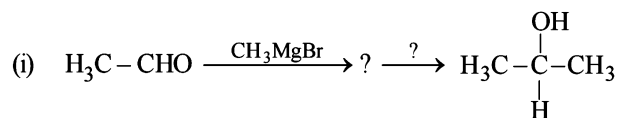

(1988 - 1 Marks)



(1988 - 1 Marks)

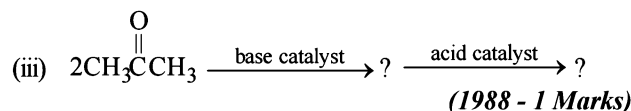

(1988 - 1 Marks)

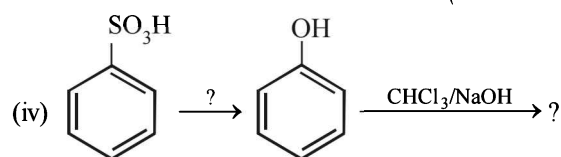

(1988 - 1 Marks)

18. A hydrocarbon A (molecular formula  $\text{C}_5\text{H}_{10}$ ) yields 2-methylbutane on catalytic hydrogenation. A adds HBr (in accordance with Markownikoff's rule) to form a compound B which on reaction with silver hydroxide forms an alcohol C,  $\text{C}_5\text{H}_{12}\text{O}$ . Alcohol C on oxidation gives a ketone D. Deduce the structures of A, B, C and D and show the reactions involved. (1988 - 5 Marks)

19. A ketone 'A' which undergoes haloform reaction gives compound B on reduction. B on heating with sulphuric acid gives compound C, which forms monoozonide D, D on hydrolysis in presence of zinc dust gives only acetaldehyde. Identify A, B and C. Write down the reactions involved. (1989 - 4 Marks)

20. The sodium salt of a carboxylic acid, A, was produced by passing a gas, B, into an aqueous solution of caustic alkali at an elevated temperature and pressure. A, on heating in presence of sodium hydroxide followed by treatment with sulphuric acid gave a dibasic acid, C. A sample of 0.4 g of acid C, on combustion gave 0.08 g of water and 0.39 g of carbon dioxide. The silver salt of the acid C weighing 1.0 g on ignition yielded 0.71 g of silver as residue. Identify A, B and C. (1990 - 5 Marks)

21. Compound A ( $\text{C}_6\text{H}_{12}\text{O}_2$ ) on reduction with  $\text{LiAlH}_4$  yielded two compounds B and C. The compound B on oxidation gave D, which on treatment with aqueous alkali and subsequent heating furnished E. The latter on catalytic hydrogenation gave C. The compound D was oxidized further to give F which was found to be a monobasic acid (molecular weight = 60.0). Deduce the structures of A, B, C, D and E. (1990 - 4 Marks)

22. An organic compound containing C, H and O exists in two isomeric forms A and B. An amount of 0.108 g of one of the isomers gives on combustion 0.308 g of  $\text{CO}_2$  and 0.072 g of  $\text{H}_2\text{O}$ . A is insoluble in NaOH and  $\text{NaHCO}_3$  while B is soluble in NaOH. A reacts with conc. HI to give compounds C and D. C can be separated from D by ethanolic  $\text{AgNO}_3$  solution and D is soluble in NaOH. B reacts readily with bromine water to give compound E of molecular formula,  $\text{C}_7\text{H}_5\text{OBr}_3$ . Identify, A, B, C, D and E with justification and give their structures. (1991 - 6 Marks)

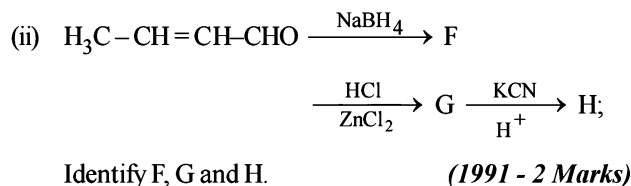
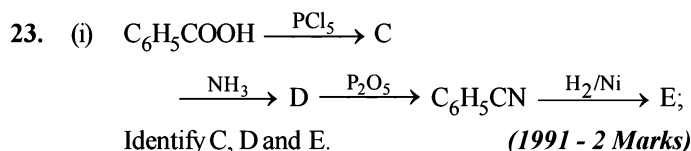

24. Compound 'X', containing chlorine on treatment with strong ammonia gives a solid 'Y' which is free from chlorine. 'Y' analysed as C = 49.31%, H = 9.59% and N = 19.18% and reacts with  $\text{Br}_2$  and caustic soda to give a basic compound 'Z'. 'Z' reacts with  $\text{HNO}_2$  to give ethanol. Suggest structures for 'X', 'Y' and 'Z'. (1992 - 1 Mark)

25. An organic compound 'A' on treatment with ethyl alcohol gives a carboxylic acid 'B' and compound 'C'. Hydrolysis of 'C' under acidic conditions gives 'B' and 'D'. Oxidation of 'D' with  $\text{KMnO}_4$  also gives 'B'. 'B' on heating with  $\text{Ca}(\text{OH})_2$  gives 'E' (molecular formula,  $\text{C}_3\text{H}_6\text{O}$ ). 'E' does not give Tollent's test and does not reduce Fehling's solution but forms a 2,4-dinitrophenylhydrazone. Identify 'A', 'B', 'C', 'D' and 'E'. (1992 - 3 Marks)

26. Arrange the following in increasing order of expected enol content (1992 - 1 Mark)

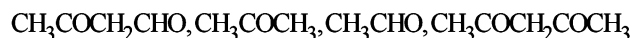

27. In the following reactions identify the compounds A, B, C and D. (1994 -  $1 \times 4 = 4$  Marks)

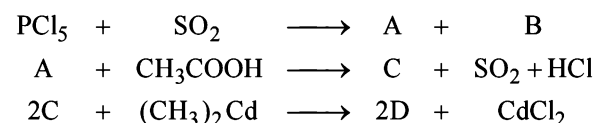

28. When gas A is passed through dry KOH at low temperature, a deep red coloured compound B and a gas C are obtained. The gas A, on reaction with but-2-ene, followed by treatment with  $\text{Zn}/\text{H}_2\text{O}$  yields acetaldehyde. Identify A, B and C. (1994 - 3 Marks)

29. An organic compound A,  $\text{C}_8\text{H}_6$ , on treatment with dilute sulphuric acid containing mercuric sulphate gives a compound B, which can also be obtained from a reaction of benzene with an acid chloride in the presence of anhydrous aluminium chloride. The compound B, when treated with iodine in aqueous KOH, yields C and a yellow compound D. Identify A, B, C and D with justification. Show how B is formed from A. (1994 - 3 Marks)

30. Which of the following carboxylic acids undergoes decarboxylation easily? Explain briefly. (1995 - 2 Marks)

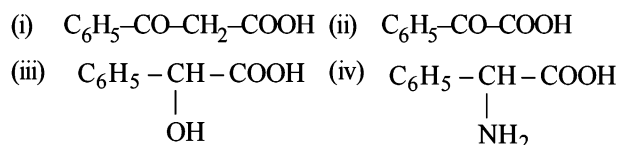

31. Suggest appropriate structures for the missing compounds. (The number of carbon atoms remains the same throughout the reactions.) (1996 - 3 Marks)

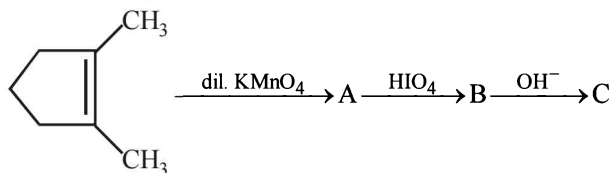

32. An ester A ( $C_4H_8O_2$ ), on treatment with excess methyl magnesium chloride followed by acidification, gives an alcohol B as the sole organic product. Alcohol B, on oxidation with NaOCl followed by acidification, gives acetic acid. Deduce the structures of A and B. Show the reactions involved. (1998 - 6 Marks)
33. An aldehyde A ( $C_{11}H_{18}O$ ), which does not undergo self aldol condensation, gives benzaldehyde and two moles of B on ozonolysis. Compound B, on oxidation with silver ion gives oxalic acid. Identify the compounds A and B. (1998 - 2 Marks)

34. Write the intermediate steps for the following reaction.

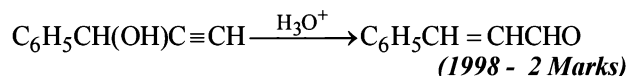

35. Complete the following reaction with appropriate structures of products/reagents : (1998 - 2 + 2 Marks)

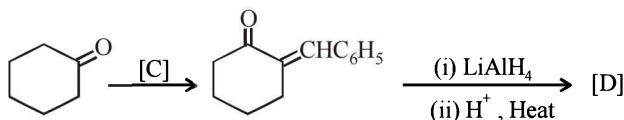

36. Complete the following reaction with appropriate reagents : (1999 - 3 Marks)

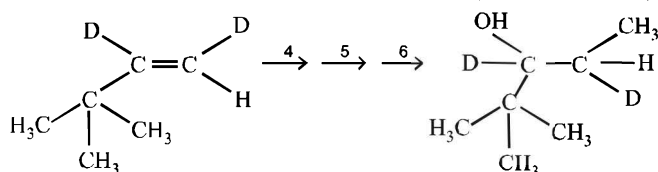

37. Explain briefly the formation of the products giving the structures of the intermediates.

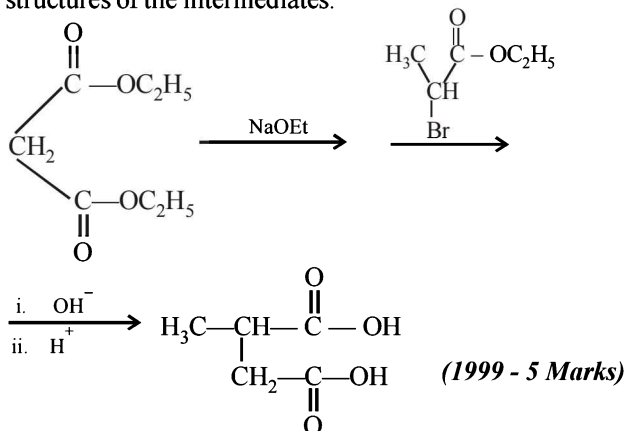

38. An organic compound A,  $C_6H_{10}O$  on reaction with  $CH_3MgBr$  followed by acid treatment gives compound B. The compound B on ozonolysis gives compound C, which in presence of a base gives 1-acetylcyclopentene D. The compound B on reaction with HBr gives compound E. Write the structures of A, B, C and E. Show how D is formed from C? (2000 - 5 Marks)

39. An organic compound A,  $C_8H_4O_3$ , in dry benzene in the presence of anhydrous  $AlCl_3$  gives compound B. The compound B on treatment with  $PCl_5$ , followed by reaction with  $H_2/Pd$  ( $BaSO_4$ ) gives compound C, which on reaction with hydrazine gives a cyclic compound D ( $C_{14}H_{10}N_2$ ). Identify A, B, C and D. Explain the formation of D from C. (2000 - 5 Marks)

40. Identify (A), (B), (C), (D) and (E) in the following schemes and write their structures : (2001 - 5 Marks)

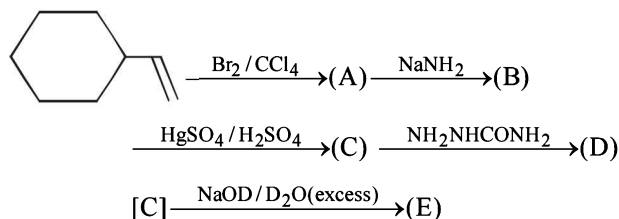

41. Identify (X), (Y) and (Z) in the following synthetic scheme and write their structures.

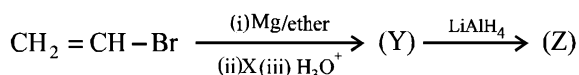
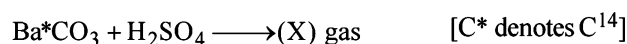

(2001 - 5 Marks)

Explain the formation of labelled formaldehyde ( $H_2C^*O$ ) as one of the products when compound (Z) is treated with HBr and subsequently ozonolysed. Mark the  $C^*$  carbon in the entire scheme.

42. Five isomeric para-disubstituted aromatic compounds A to E with molecular formula  $C_8H_8O_2$  were given for identification. Based on the following observations, give structures of the compounds. (2002 - 5 Marks)

- Both A and B form a silver mirror with Tollen's reagent; also B gives a positive test with  $FeCl_3$  solution.
- C gives positive iodoform test.
- D is readily extracted in aqueous  $NaHCO_3$  solution.
- E on acid hydrolysis gives 1,4-dihydroxybenzene.

43. Identify X, Y and Z in the following synthetic scheme and write their structures.

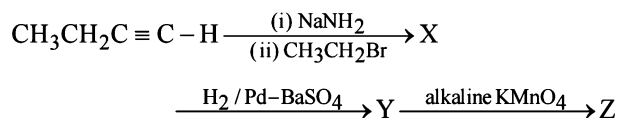

Is the compound Z optically active? Justify your answer.

(2002 - 5 Marks)

44. A racemic mixture of ( $\pm$ ) 2-phenylpropanoic acid on esterification with (+) 2-butanol gives two esters. Mention the stereochemistry of the two esters produced. (2003 - 2 Marks)

45. Compound A of molecular formula  $C_9H_7O_2Cl$  exists in keto form and predominantly in enolic form 'B'. On oxidation with  $KMnO_4$ , 'A' gives *m*-chlorobenzoic acid. Identify 'A' and 'B'. (2003 - 2 Marks)

46. A monomer of a polymer on ozonolysis gives two moles of  $CH_2O$  and one mole of  $CH_3COCHO$ . Write the structure of monomer and write all - 'cis' configuration of polymer chain. (2005 - 2 Marks)

## F Match the Following

**DIRECTIONS (Q. No. 1) :** Each question contains statements given in two columns, which have to be matched. The statements in Column-I are labelled A, B, C and D, while the statements in Column-II are labelled p, q, r, s and t. Any given statement in Column-I can have correct matching with ONE OR MORE statement(s) in Column-II. The appropriate bubbles corresponding to the answers to these questions have to be darkened as illustrated in the following example :

If the correct matches are A-p, s and t; B-q and r; C-p and q; and D-s then the correct darkening of bubbles will look like the given.

	p	q	r	s	t
A	<input checked="" type="radio"/>	<input checked="" type="radio"/>	<input type="radio"/>	<input checked="" type="radio"/>	<input checked="" type="radio"/>
B	<input type="radio"/>	<input checked="" type="radio"/>	<input checked="" type="radio"/>	<input type="radio"/>	<input type="radio"/>
C	<input checked="" type="radio"/>	<input checked="" type="radio"/>	<input type="radio"/>	<input type="radio"/>	<input type="radio"/>
D	<input type="radio"/>	<input type="radio"/>	<input type="radio"/>	<input checked="" type="radio"/>	<input type="radio"/>

1. Match the entries in Column I with the correctly related quantum number(s) in Column II. Indicate your answer by darkening the appropriate bubbles of the  $4 \times 4$  matrix given in the ORS (2008)

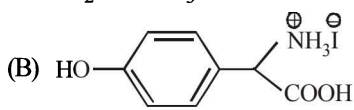
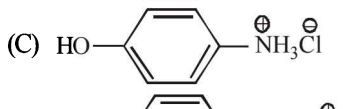
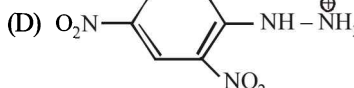
Column I	Column II
(A) $\text{H}_2\text{N}-\overset{\oplus}{\text{N}}\text{H}_3\overset{\ominus}{\text{Cl}}$	(p) sodium fusion extract of the compound gives Prussian blue colour with $\text{FeSO}_4$
(B) 	(q) gives positive $\text{FeCl}_3$ test
(C) 	(r) gives white precipitate with $\text{AgNO}_3$
(D) 	(s) reacts with aldehydes to form the corresponding hydrazone derivative

**DIRECTIONS (Q. No. 2) :** Following question has matching lists. The codes for the list have choices (a), (b), (c) and (d) out of which ONLY ONE is correct.

2. Different possible **thermal** decomposition pathways for peroxyesters are shown below. Match each pathway from **List-I** with an appropriate structure from **List-II** and select the correct answer using the code given below the lists. (JEE Adv. 2014)

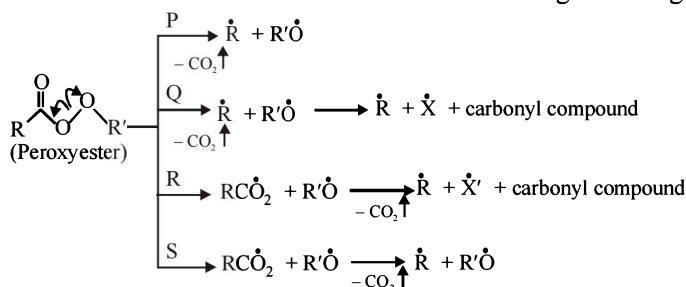

### List-I

- P. Pathway P
- Q. Pathway Q
- R. Pathway R
- S. Pathway S

### List-II

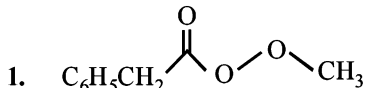
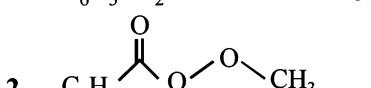
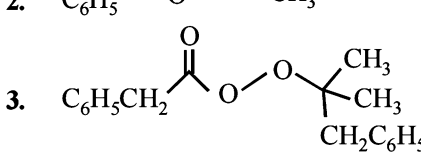
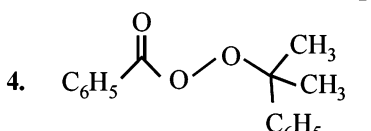
1. 
2. 
3. 
4. 

### Code :

	P	Q	R	S
(a)	1	3	4	2
(b)	2	4	3	1

	P	Q	R	S
(c)	4	1	2	3
(d)	3	2	1	4

## G Comprehension Based Questions

### PASSAGE-1

In the following reaction sequence, product I, J and L are formed. K represents a reagent. (2008)

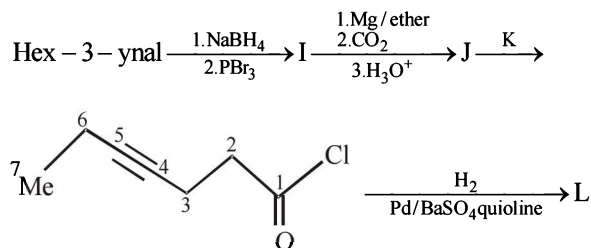

1. The structure of the product I is –

- (a)
- (b)
- (c)
- (d)

2. The structures of compound J and K, respectively, are

- (a)
- (b)
- (c)
- (d)

3. The structure of product L is

- (a)
- (b)
- (c)
- (d)

### PASSAGE-2

A carbonyl compound P, which gives positive iodoform test, undergoes reaction with  $\text{MeMgBr}$  followed by dehydration to give an olefin Q. Ozonolysis of Q leads to a dicarbonyl compound R, which undergoes intramolecular aldol reaction to give predominantly S. (2009)

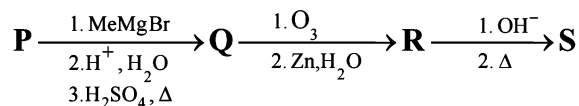

4. The structure of the carbonyl compound P is

- (a)
- (b)
- (c)
- (d)

5. The structures of the products Q and R, respectively, are

- (a)
- (b)
- (c)
- (d)

6. The structure of the product S is

- (a)
- (b)
- (c)
- (d)

### PASSAGE-3

Two aliphatic aldehydes P and Q react in the presence of aqueous  $\text{K}_2\text{CO}_3$  to give compound R, which upon treatment with HCN provides compound S. On acidification and heating, S gives the product shown below. (2010)

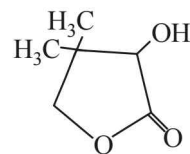

7. The compounds P and Q respectively are :

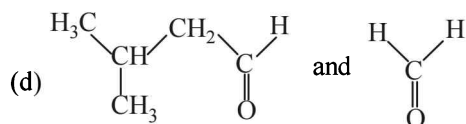
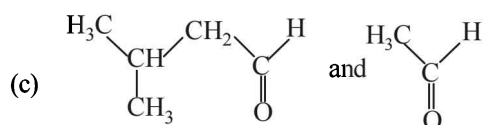
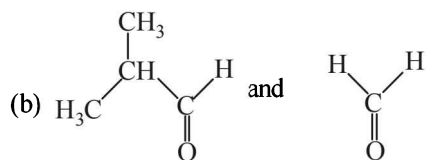
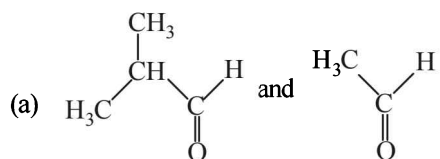

8. The compound R is :

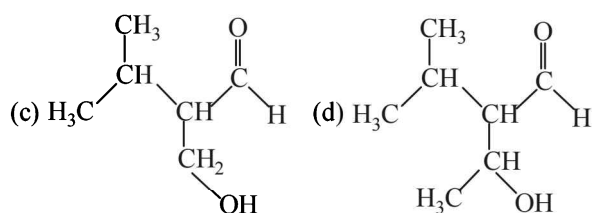
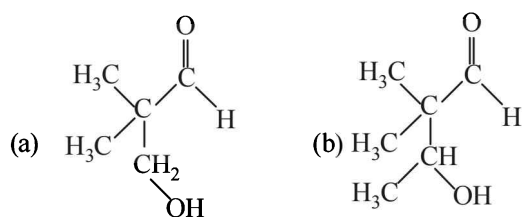

9. The compound S is :

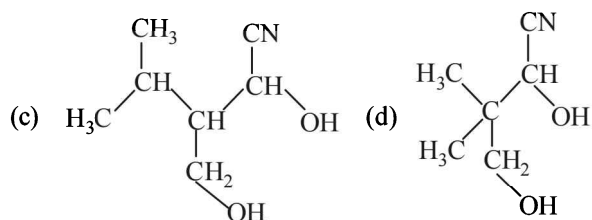
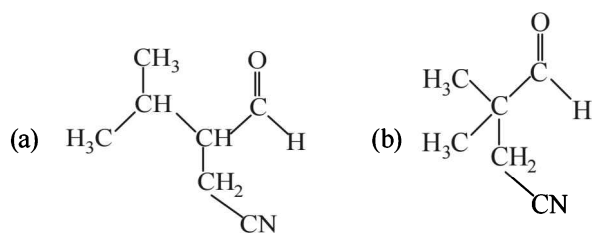

### PASSAGE-4

In the following reaction sequence, the compound J is an intermediate.

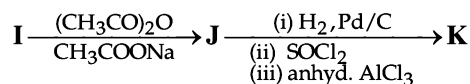

J ( $\text{C}_9\text{H}_8\text{O}_2$ ) gives effervescence on treatment with  $\text{NaHCO}_3$  and a positive Baeyer's test. (2012)

10. The compound I is

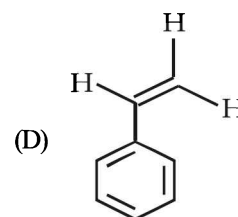
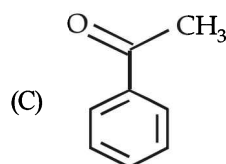
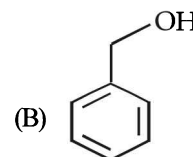
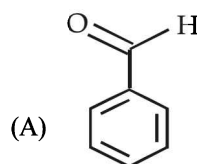

11. The compound K is

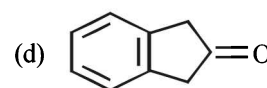
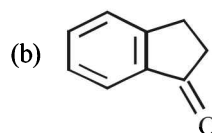
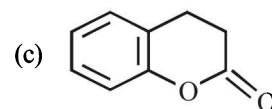
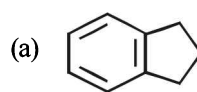

### PASSAGE-5

P and Q are isomers of dicarboxylic acid  $\text{C}_4\text{H}_4\text{O}_4$ . Both decolorize  $\text{Br}_2/\text{H}_2\text{O}$ . On heating, P forms the cyclic anhydride. Upon treatment with dilute alkaline  $\text{KMnO}_4$ , P as well as Q could produce one or more than one from S, T and U.

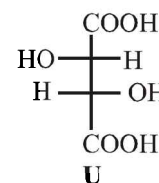
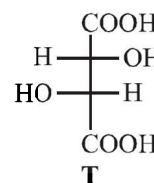
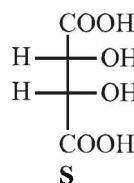

(JEE Adv. 2013)

12. Compounds formed from P and Q are, respectively

- (a) Optically active S and optically active pair (T, U)  
 (b) Optically inactive S and optically inactive pair (T, U)  
 (c) Optically active pair (T, U) and optically active S  
 (d) Optically inactive pair (T, U) and optically inactive S

13. In the following reaction sequences V and W are respectively

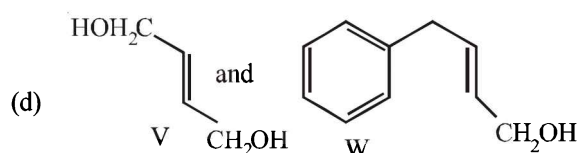
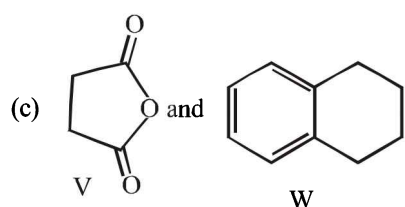
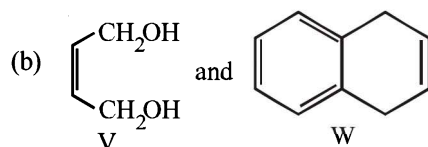
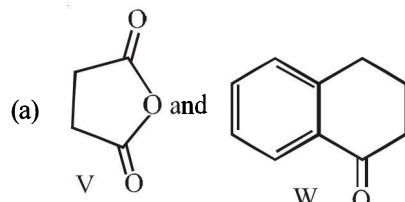
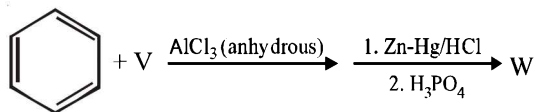
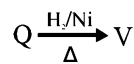

#### PASSAGE-6

In the following reactions

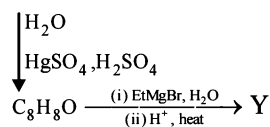
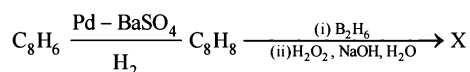

14. Compound X is

(JEE Adv. 2015)

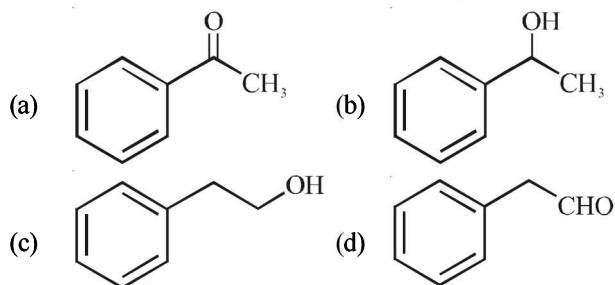

15. The major compound Y is

(JEE Adv. 2015)

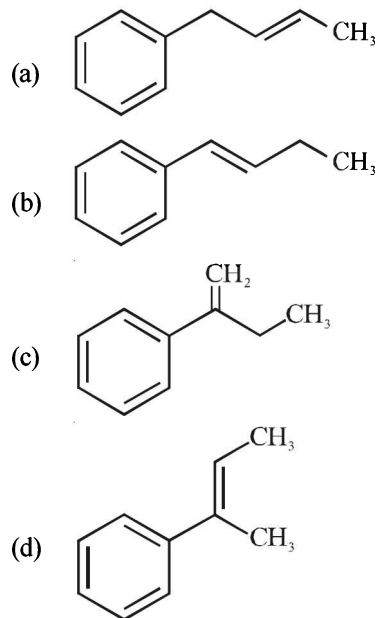

#### II Assertion & Reason Type Questions

Each of this question contains STATEMENT-1 (Assertion/Statement) and STATEMENT-2 (Reason/Explanation) and has 4 choices (a), (b), (c) and (d) out of which ONLY ONE is correct.

- (a) Statement-1 is True, Statement-2 is True; Statement-2 is a correct explanation for Statement-1  
 (b) Statement-1 is True, Statement-2 is True; Statement-2 is NOT a correct explanation for Statement-1  
 (c) Statement-1 is True, Statement-2 is False  
 (d) Statement-1 is False, Statement-2 is True.

- Statement-1** : Acetate ion is more basic than the methoxide ion.  
**Statement-2** : The acetate ion is resonance stabilized  
(1994 - 2 Marks)
- Statement-1** : Acetic acid does not undergo haloform reaction.  
**Statement-2** : Acetic acid has no alpha hydrogens.  
(1998 - 2 Marks)
- Statement-1** : Dimethyl sulphide is commonly used for the reduction of an ozonide of an alkene to get the carbonyl compounds.  
**Statement-2** : It reduces the ozonide giving water soluble dimethyl sulphoxide and excess of it evaporates. (2001S)
- Statement-1** : *p*-Hydroxybenzoic acid has a lower boiling point than *o*-hydroxybenzoic acid.  
**Statement-2** : *o*-Hydroxybenzoic acid has intramolecular hydrogen bonding. (2007)

#### I Integer Value Correct Type

1. In the scheme given below, the total number of intramolecular aldol condensation products formed from 'Y' is

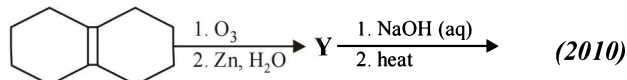

2. Amongst the following, the total number of compounds soluble in aqueous NaOH is

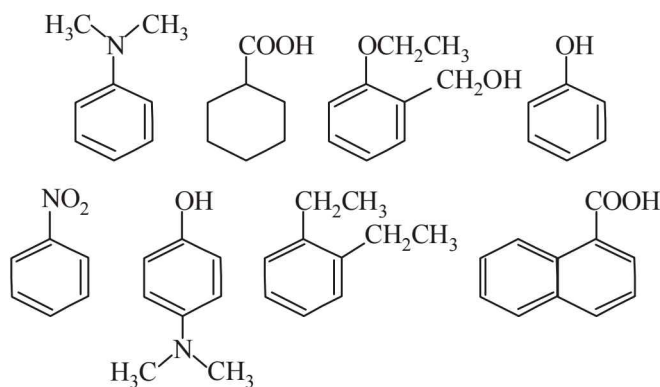

(2010)

3. The total number of carboxylic acid groups in the product P is

(JEE Adv. 2013)

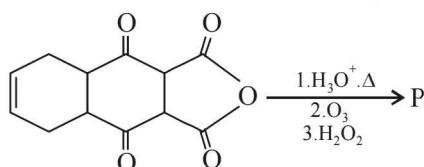

4. Consider all possible isomeric ketones, including stereoisomers of MW = 100. All these isomers are independently reacted with  $\text{NaBH}_4$  (NOTE: stereoisomers are also reacted separately). The total number of ketones that give a racemic product(s) is/are (JEE Adv. 2014)
5. Among the following, the number of reaction(s) that produce(s) benzaldehyde is (JEE Adv. 2015)

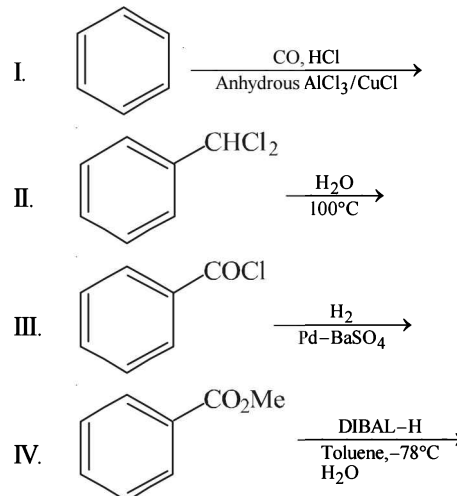

## Section-B

## JEE Main / AIEEE

1.  $\text{CH}_3\text{CH}_2\text{COOH} \xrightarrow[\text{redP}]{\text{Cl}_2} A \xrightarrow{\text{alc. KOH}} B$ . What is B?
- (a)  $\text{CH}_3\text{CH}_2\text{COCl}$  (b)  $\text{CH}_3\text{CH}_2\text{CHO}$  [2002]  
 (c)  $\text{CH}_2=\text{CHCOOH}$  (d)  $\text{ClCH}_2\text{CH}_2\text{COOH}$
2. On vigorous oxidation by permanganate solution.  $(\text{CH}_3)_2\text{C}=\text{CH}-\text{CH}_2-\text{CHO}$  gives [2002]

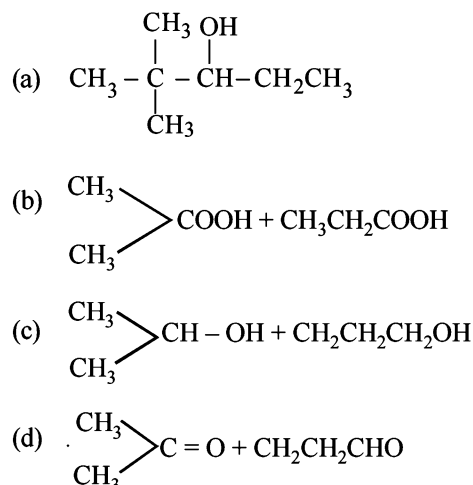

3. Picric acid is: [2002]

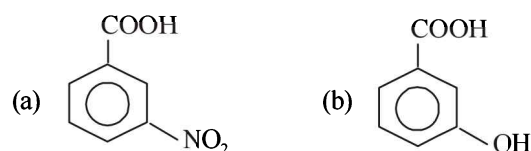

- (c)
- (d)
4. When  $\text{CH}_2=\text{CH}-\text{COOH}$  is reduced with  $\text{LiAlH}_4$ , the compound obtained will be [2003]  
 (a)  $\text{CH}_2=\text{CH}-\text{CH}_2\text{OH}$  (b)  $\text{CH}_3-\text{CH}_2-\text{CH}_2\text{OH}$   
 (c)  $\text{CH}_3-\text{CH}_2-\text{CHO}$  (d)  $\text{CH}_3-\text{CH}_2-\text{COOH}$
5. On mixing ethyl acetate with aqueous sodium chloride, the composition of the resultant solution is [2004]  
 (a)  $\text{CH}_3\text{COCl} + \text{C}_2\text{H}_5\text{OH} + \text{NaOH}$   
 (b)  $\text{CH}_3\text{COONa} + \text{C}_2\text{H}_5\text{OH}$   
 (c)  $\text{CH}_3\text{COOC}_2\text{H}_5 + \text{NaCl}$   
 (d)  $\text{CH}_3\text{Cl} + \text{C}_2\text{H}_5\text{COONa}$
6. Acetyl bromide reacts with excess of  $\text{CH}_3\text{MgI}$  followed by treatment with a saturated solution of  $\text{NH}_4\text{Cl}$  gives [2004]  
 (a) 2-methyl-2-propanol (b) acetamide  
 (c) acetone (d) acetyl iodide
7. Which one of the following is reduced with zinc and hydrochloric acid to give the corresponding hydrocarbon? [2004]  
 (a) Acetamide (b) Acetic acid  
 (c) Ethyl acetate (d) Butan-2-one
8. Which one of the following undergoes reaction with 50% sodium hydroxide solution to give the corresponding alcohol and acid? [2004]  
 (a) Butanal (b) Benzaldehyde  
 (c) Phenol (d) Benzoic acid

9. Among the following acids which has the lowest  $pK_a$  value? [2005]  
 (a)  $\text{CH}_3\text{CH}_2\text{COOH}$  (b)  $(\text{CH}_3)_2\text{CH}-\text{COOH}$   
 (c)  $\text{HCOOH}$  (d)  $\text{CH}_3\text{COOH}$
10. Reaction of cyclohexanone with dimethylamine in the presence of catalytic amount of an acid forms a compound if water during the reaction is continuously removed. The compound formed is generally known as [2005]  
 (a) an amine (b) an imine  
 (c) an anemine (d) a Schiff's base
11. The increasing order of the rate of  $\text{HCN}$  addition to compound A – D is [2006]  
 (A)  $\text{HCHO}$  (B)  $\text{CH}_3\text{COCH}_3$   
 (C)  $\text{PhCOCH}_3$  (D)  $\text{PhCOPh}$   
 (a)  $\text{D} < \text{C} < \text{B} < \text{A}$  (b)  $\text{C} < \text{D} < \text{B} < \text{A}$   
 (c)  $\text{A} < \text{B} < \text{C} < \text{D}$  (d)  $\text{D} < \text{B} < \text{C} < \text{A}$
12. The correct order of increasing acid strength of the compounds [2006]  
 (A)  $\text{CH}_3\text{CO}_2\text{H}$  (B)  $\text{MeOCH}_2\text{CO}_2\text{H}$   
 (C)  $\text{CF}_3\text{CO}_2\text{H}$  (D)  $\begin{array}{c} \text{Me} \\ \diagdown \\ \text{C} \\ \diagup \\ \text{Me} \end{array} \text{CO}_2\text{H}$   
 is  
 (a)  $\text{D} < \text{A} < \text{B} < \text{C}$  (b)  $\text{A} < \text{D} < \text{B} < \text{C}$   
 (c)  $\text{B} < \text{D} < \text{A} < \text{C}$  (d)  $\text{D} < \text{A} < \text{C} < \text{B}$
13. A liquid was mixed with ethanol and a drop of concentrated  $\text{H}_2\text{SO}_4$  was added. A compound with a fruity smell was formed. The liquid was : [2009]  
 (a)  $\text{HCHO}$  (b)  $\text{CH}_3\text{COCH}_3$   
 (c)  $\text{CH}_3\text{COOH}$  (d)  $\text{CH}_3\text{OH}$
14. Which of the following on heating with aqueous  $\text{KOH}$ , produces acetaldehyde? [2009]  
 (a)  $\text{CH}_3\text{CH}_2\text{Cl}$  (b)  $\text{CH}_2\text{ClCH}_2\text{Cl}$   
 (c)  $\text{CH}_3\text{CHCl}_2$  (d)  $\text{CH}_3\text{COCI}$
15. In Cannizzaro reaction given below  

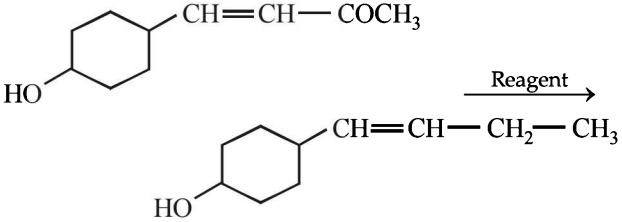
$$2\text{PhCHO} \xrightarrow{:\text{OH}^-} \text{PhCH}_2\text{OH} + \text{PhC}\overset{\ominus}{\text{O}}_2$$
  
 the slowest step is : [2009]  
 (a) the transfer of hydride to the carbonyl group  
 (b) the abstraction of proton from the carboxylic group  
 (c) the deprotonation of  $\text{PhCH}_2\text{OH}$   
 (d) the attack of  $:\text{OH}^-$  at the carboxyl group
16. Which of the following reagents may be used to distinguish between phenol and benzoic acid? [2011]  
 (a) Aqueous  $\text{NaOH}$  (b) Tollen's reagent  
 (c) Molisch reagent (d) Neutral  $\text{FeCl}_3$
17. Trichloroacetaldehyde was subjected to Cannizzaro's reaction by using  $\text{NaOH}$ . The mixture of the products contains sodium trichloroacetate and another compound. The other compound is : [2011]  
 (a) 2, 2, 2-Trichloroethanol  
 (b) Trichloromethanol  
 (c) 2, 2, 2-Trichloropropanol  
 (d) Chloroform
18. The strongest acid amongst the following compounds is : [2011]  
 (a)  $\text{CH}_3\text{COOH}$   
 (b)  $\text{HCOOH}$   
 (c)  $\text{CH}_3\text{CH}_2\text{CH}(\text{Cl})\text{CO}_2\text{H}$   
 (d)  $\text{ClCH}_2\text{CH}_2\text{CH}_2\text{COOH}$
19. Sodium ethoxide has reacted with ethanoyl chloride. The compound that is produced in the above reaction is : [2011]  
 (a) Diethyl ether (b) 2-Butanone  
 (c) Ethyl chloride (d) Ethyl ethanoate
20. Silver Mirror test is given by which one of the following compounds? [2011]  
 (a) Acetaldehyde (b) Acetone  
 (c) Formaldehyde (d) Benzophenone
21. Iodoform can be prepared from all except : [2012]  
 (a) Ethyl methyl ketone  
 (b) Isopropyl alcohol  
 (c) 3-Methyl 2-butanone  
 (d) Isobutyl alcohol
22. In the given transformation, which of the following is the most appropriate reagent ? [2012]  

- (a)  $\text{NH}_2\text{NH}_2, \overset{\ominus}{\text{O}}\text{H}$  (b)  $\text{Zn}-\text{Hg}/\text{HCl}$   
 (c)  $\text{Na}, \text{Liq NH}_3$  (d)  $\text{NaBH}_4$
23. The most suitable reagent for the conversion of  $\text{R}-\text{CH}_2-\text{OH} \rightarrow \text{R}-\text{CHO}$  is: [JEE M 2014]  
 (a)  $\text{KMnO}_4$   
 (b)  $\text{K}_2\text{Cr}_2\text{O}_7$   
 (c)  $\text{CrO}_3$   
 (d) PCC (Pyridinium Chlorochromate)
24. In the reaction,  

$$\text{CH}_3\text{COOH} \xrightarrow{\text{LiAlH}_4} \text{A} \xrightarrow{\text{PCl}_5} \text{B} \xrightarrow{\text{Alc.KOH}} \text{C},$$
  
 the product C is: [JEE M 2014]  
 (a) Acetaldehyde (b) Acetylene  
 (c) Ethylene (d) Acetyl chloride
25. In the following sequence of reactions : [JEE M 2015]  

$$\text{Toluene} \xrightarrow{\text{KMnO}_4} \text{A} \xrightarrow{\text{SOCl}_2} \text{B} \xrightarrow[\text{BaSO}_4]{\text{H}_2/\text{Pd}} \text{C}$$
  
 the product C is :  
 (a)  $\text{C}_6\text{H}_5\text{CH}_2\text{OH}$  (b)  $\text{C}_6\text{H}_5\text{CHO}$   
 (c)  $\text{C}_6\text{H}_5\text{COOH}$  (d)  $\text{C}_6\text{H}_5\text{CH}_3$



# CHAPTER 21

# Compounds Containing Nitrogen

## Section-A JEE Advanced/ IIT-JEE

### A Fill in the Blanks

- In an acidic medium, ..... behaves as the strongest base. (nitrobenzene, aniline, phenol) (1981 - 1 Mark)
- Amongst the three isomers of nitrophenol, the one that is least soluble in water is ..... (1992 - 1 Mark)
- The high melting point and insolubility in organic solvents of sulphanilic acid are due to its.....structure. (1994 - 1 Mark)

### C MCQs with One Correct Answer

- The compound which on reaction with aqueous nitrous acid at low temperature produces an oily nitrosamine is (1981 - 1 Mark)
  - methylamine
  - ethylamine
  - diethylamine
  - triethylamine
- Acetamide is treated separately with the following reagents. Which one of these would give methylamine? (1983 - 1 Mark)
  - $\text{PCl}_5$
  - $\text{NaOH} + \text{Br}_2$
  - soda lime
  - hot conc.  $\text{H}_2\text{SO}_4$
- Carbylamine test is performed in alcoholic KOH by heating a mixture of: (1984 - 1 Mark)
  - chloroform and silver powder
  - trihalogenated methane and a primary amine
  - an alkyl halide and a primary amine
  - an alkyl cyanide and a primary amine
- The compound that is most reactive towards electrophilic nitration is : (1985 - 1 Mark)
  - toluene
  - benzene
  - benzoic acid
  - nitrobenzene
- If two compounds have the same empirical formula but different molecular formulae they must have (1987 - 1 Mark)
  - different percentage composition
  - different molecular weight
  - same viscosity
  - same vapour density
- Amongst the following, the most basic compound is : (1990 - 1 Mark)
  - Benzylamine
  - Aniline
  - Acetanilide
  - p*-Nitroaniline

- The formation of cyanohydrin from a ketone is an example of: (1990 - 1 Mark)
  - Electrophilic addition
  - Nucleophilic addition
  - Nucleophilic substitution
  - Electrophilic substitution
- Butanonitrile may be prepared by heating : (1992 - 1 Mark)
  - Propyl alcohol with KCN
  - Butyl alcohol with KCN
  - Butyl chloride with KCN
  - Propyl chloride with KCN
- In the reaction *p*-chlorotoluene with  $\text{KNH}_2$  in liq.  $\text{NH}_3$ , the major product is: (1997 - 1 Mark)
  - o*-toluidine
  - m*-toluidine
  - p*-toluidine
  - p*-chloroaniline.
- The most unlikely representation of resonance structures of *p*-nitrophenoxide ion is (1999 - 2 Marks)

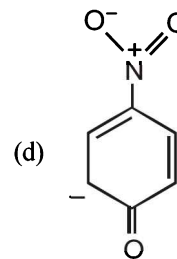
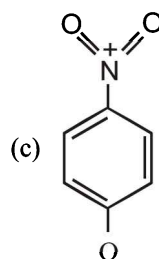
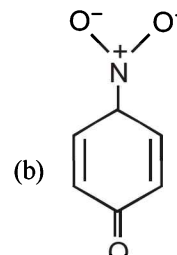
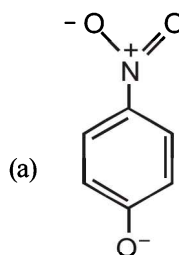

- Among the following, the strongest base is (2000S)
  - $\text{C}_6\text{H}_5\text{NH}_2$
  - p*- $\text{NO}_2\text{C}_6\text{H}_4\text{NH}_2$
  - m*- $\text{NO}_2\text{C}_6\text{H}_4\text{NH}_2$
  - $\text{C}_6\text{H}_5\text{CH}_2\text{NH}_2$

12. The correct order of basicities of the following compounds is (2001S)

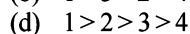
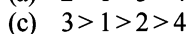
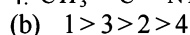
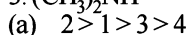
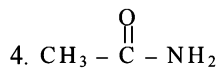
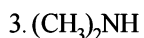
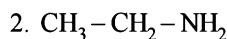
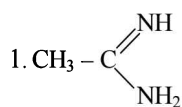

13. Compound 'A' (molecular formula  $\text{C}_3\text{H}_8\text{O}$ ) is treated with acidified potassium dichromate to form a product 'B' (molecular formula  $\text{C}_3\text{H}_6\text{O}$ ). 'B' forms a shining silver mirror on warming with ammonical silver nitrate. 'B' when treated with an aqueous solution of  $\text{H}_2\text{NCONHNH}_2 \cdot \text{HCl}$  and sodium acetate gives a product 'C'. Identify the structure of 'C'.

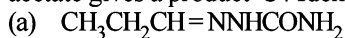

(2002S)

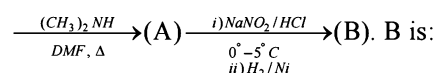
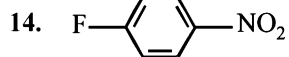
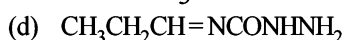
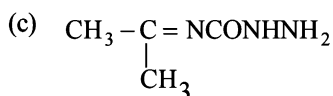
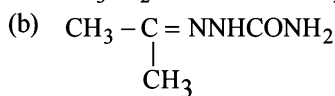

(2003S)

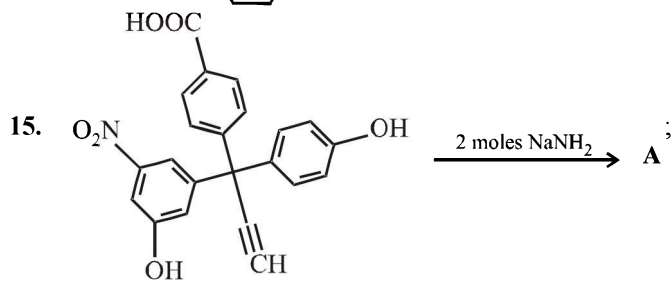
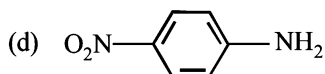
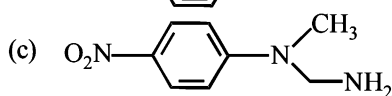
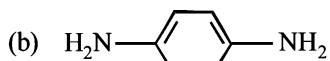
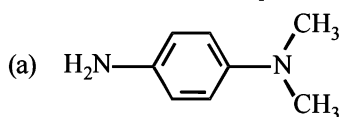

The product A will be

(2003S)

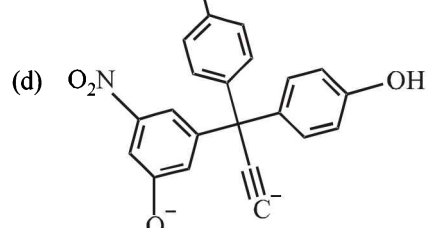
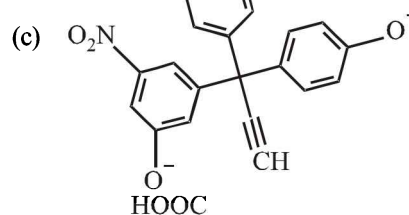
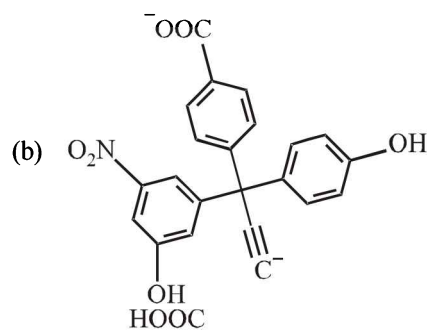
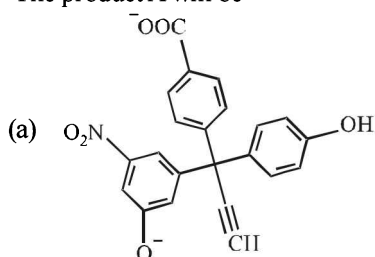

16. Benzamide on reaction with  $\text{POCl}_3$  gives (2004S)

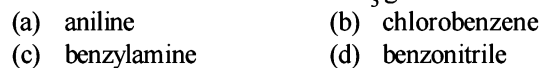

17. The major product obtained when  $\text{Br}_2/\text{Fe}$  is treated with

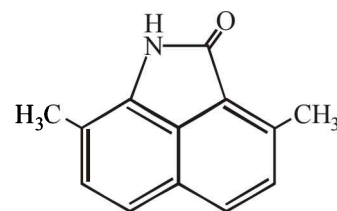

(2004S)

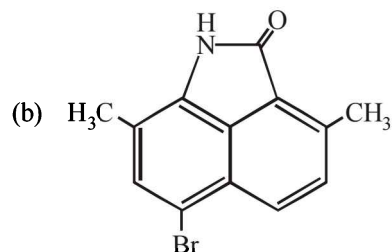
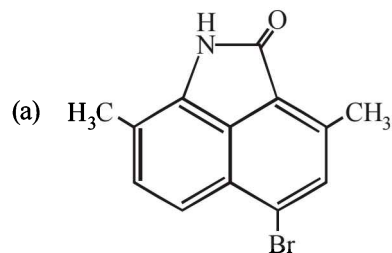

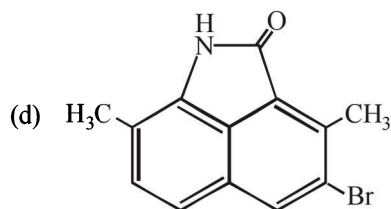
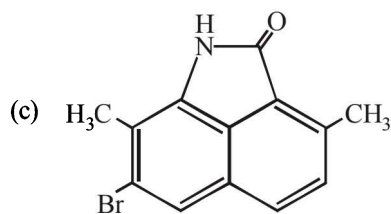

18. In the compound given below the correct order of the acidity of the positions X, Y and Z is (2004S)

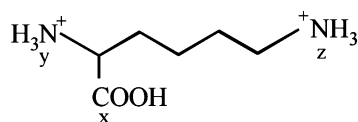

- (a)  $Z > X > Y$  (b)  $X > Y > Z$   
 (c)  $X > Z > Y$  (d)  $Y > X > Z$
19. When benzenesulfonic acid and *p*-nitrophenol are treated with  $\text{NaHCO}_3$ , the gases released respectively are (2006)
- (a)  $\text{SO}_2, \text{NO}$  (b)  $\text{SO}_2, \text{NO}_2$   
 (c)  $\text{CO}_2, \text{CO}_2$  (d)  $\text{SO}_2, \text{CO}_2$
20. In the following reaction, (2006)

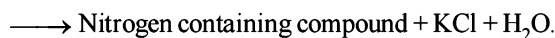
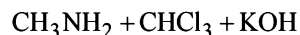

The nitrogen containing compound is

- (a)  $\text{CH}_3 - \text{NH} - \text{CH}_3$  (b)  $\text{CH}_3 - \text{C} \equiv \text{N}$   
 (c)  $\text{CH}_3 - \overset{+}{\text{N}} \equiv \overset{-}{\text{C}}$  (d)  $\text{CH}_3 - \overset{-}{\text{N}} \equiv \overset{+}{\text{C}}$
21. The correct stability order of the following resonance structures is (2009)



- (a) (I) > (II) > (IV) > (III)  
 (b) (I) > (III) > (II) > (IV)  
 (c) (II) > (I) > (III) > (IV)  
 (d) (III) > (I) > (IV) > (II)
22. The major product of the following reaction is (2011 - I)

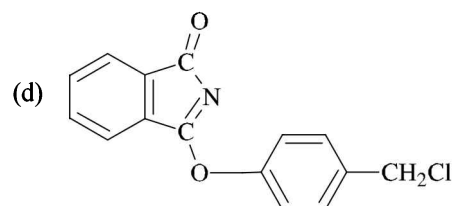
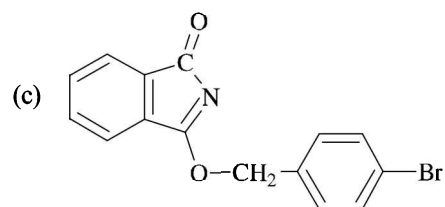
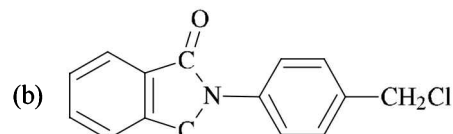
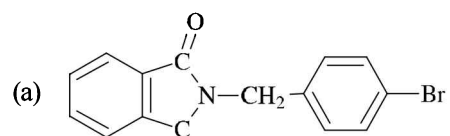
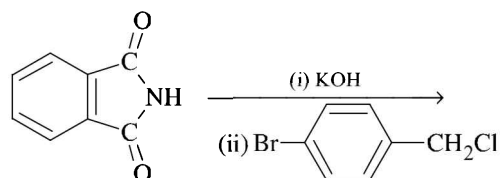

23. Amongst the compounds given, the one that would form a brilliant colored dye on treatment with  $\text{NaNO}_2$  in dil. HCl followed by addition to an alkaline solution of  $\beta$ -naphthol is (2011 - II)

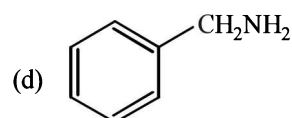
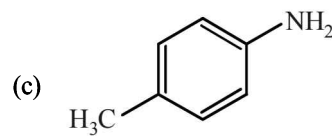
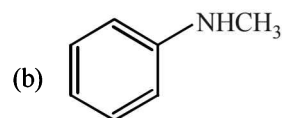
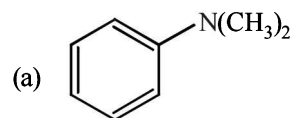

## D MCQs with One or More Than One Correct

1. The products of reaction of alcoholic silver nitrite with ethyl bromide are (1991 - 1 Mark)
- (a) ethane (b) ethene  
 (c) nitroethane (d) ethyl alcohol  
 (e) ethyl nitrite

2. Reaction of  $R-\overset{\text{O}}{\parallel}{C}-NH_2$  with a mixture of  $Br_2$  and  $KOH$  gives  $R-NH_2$  as the main product. The intermediates involved in this reaction are: (1992 - 1 Mark)

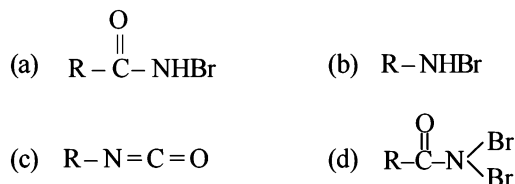

3. When nitrobenzene is treated with  $Br_2$  in presence of  $FeBr_3$ , the major product formed is *m*-bromonitrobenzene. Statements which are related to obtain the *m*-isomer are (1992 - 1 Mark)
- (a) The electron density on meta carbon is more than that on ortho and para positions  
 (b) The intermediate carbonium ion formed after initial attack of  $Br^+$  at the meta position is least destabilised  
 (c) Loss of aromaticity when  $Br^+$  attacks at the ortho and para positions and not at meta position  
 (d) Easier loss of  $H^+$  to regain aromaticity from the meta position than from ortho and para positions.
4. Examine the following two structures for the anilinium ion and choose the correct statement from the ones given below: (1993 - 1 Mark)

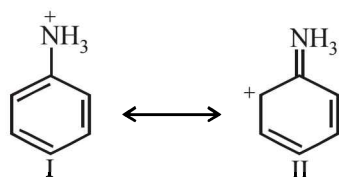

- (a) II is not an acceptable canonical structure because carbonium ions are less stable than ammonium ions.  
 (b) II is not an acceptable canonical structure because it is non-aromatic.  
 (c) II is not an acceptable canonical structure because the nitrogen has 10 valence electrons.  
 (d) II is an acceptable canonical structure.
5. *p*-Chloroaniline and anilinium hydrochloride can be distinguished by (1998 - 2 Marks)
- (a) Sandmeyer reaction (b)  $NaHCO_3$   
 (c)  $AgNO_3$  (d) Carbylamine test
6. Among the following compounds, which will react with acetone to give a product containing  $>C=N$ -bond? (1998 - 2 Marks)
- (a)  $C_6H_5NH_2$  (b)  $(CH_3)_3N$   
 (c)  $C_6H_5NHC_6H_5$  (d)  $C_6H_5NHNH_2$
7. Benzenediazonium chloride on reaction with phenol in weakly basic medium gives (1998 - 2 Marks)
- (a) diphenyl ether (b) *p*-hydroxyazobenzene  
 (c) chlorobenzene (d) benzene

8. A positive carbylamine test is given by (1999 - 2 Marks)
- (a) *N,N*-dimethylaniline  
 (b) 2,4-dimethylaniline  
 (c) *N*-methyl-*o*-methylaniline  
 (d) *p*-methylbenzylamine
9. In the reaction  $2X + B_2H_6 \rightarrow [BH_2(X)_2]^+ [BH_4]^-$  the amine(s) X is (are) (2009)
- (a)  $NH_3$  (b)  $CH_3NH_2$   
 (c)  $(CH_3)_2NH$  (d)  $(CH_3)_3N$
10. Hydrogen bonding plays a central role in the following phenomena (JEE Adv. 2014)
- (a) Ice floats in water  
 (b) Higher Lewis basicity of primary amines than tertiary amines in aqueous solutions  
 (c) Formic acid is more acidic than acetic acid  
 (d) Dimerisation of acetic acid in benzene
11. In the reaction shown below, the major product(s) formed is/are (JEE Adv. 2014)

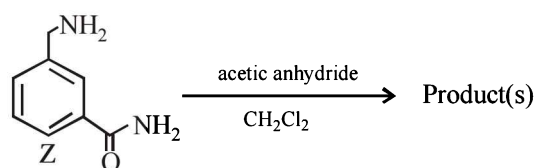

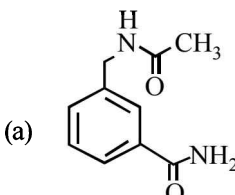
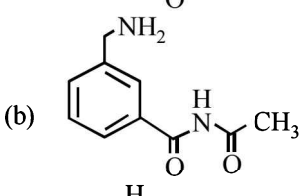
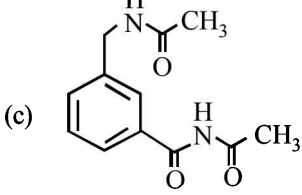
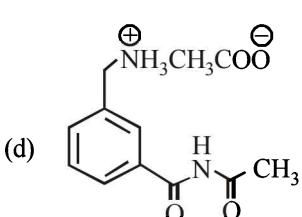
- (a)  +  $CH_3COOH$
- (b)  +  $CH_3COOH$
- (c)  +  $H_2O$
- (d) 

12. The major product of the reaction is (JEE Adv. 2015)

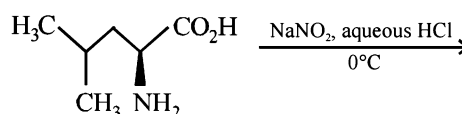

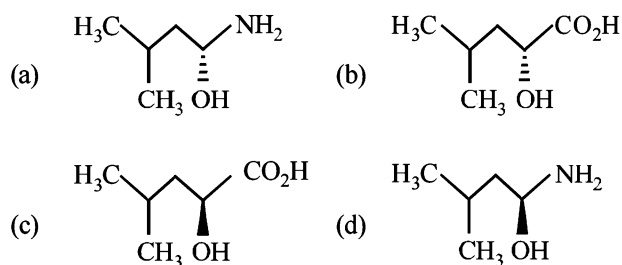

13. In the following reactions, the major product W is

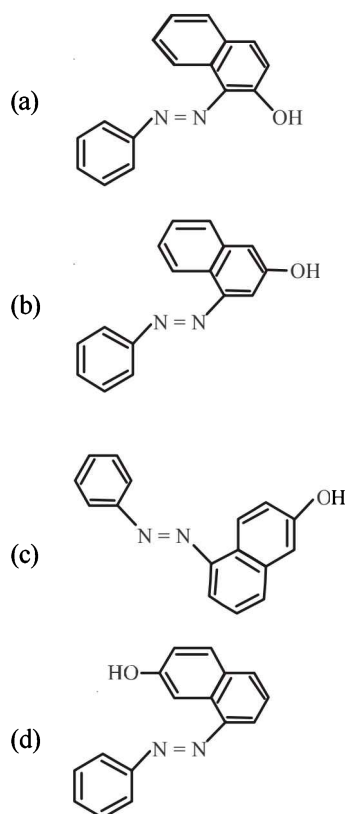
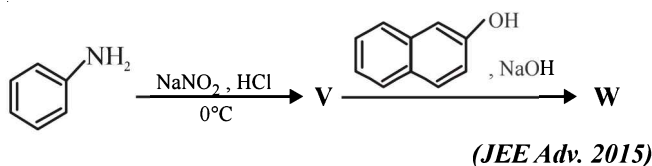

14. In the following reactions, the product S is (JEE Adv. 2015)

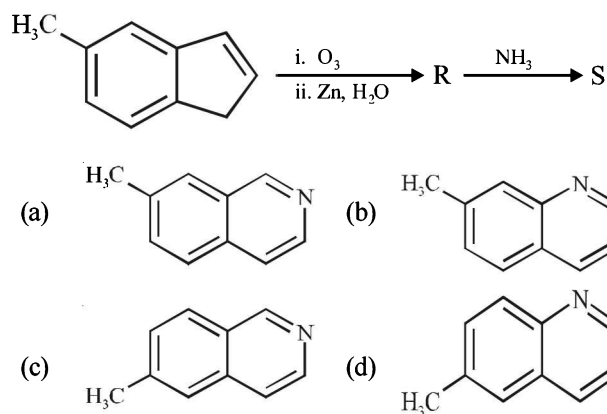

15. The product(s) of the following reaction sequence is(are) (JEE Adv. 2016)

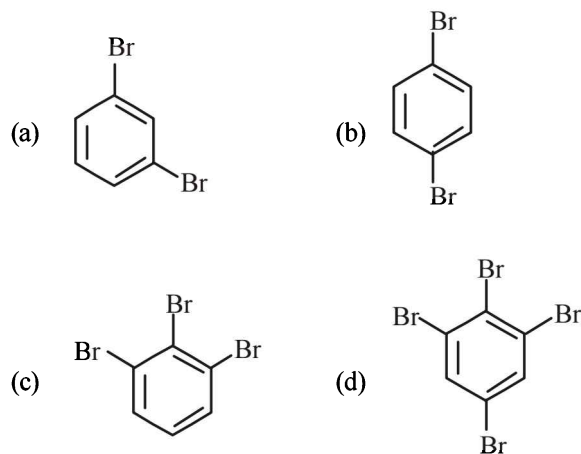
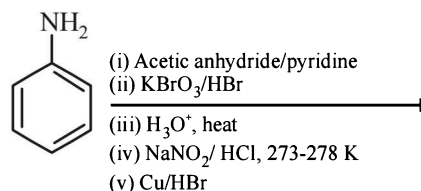

## E Subjective Problems

- Show with equations how the following compounds are prepared (equations need not be balanced):
  - n-propyl amine from ethyl chloride (in two steps) (1982 - 1 Mark)
  - chlorobenzene from aniline (in two steps). (1982 - 1 Mark)
  - Aniline from benzene (1983 - 1 Mark)
  - Acetoxime from acetaldehyde using the reagents,  $[K_2Cr_2O_7/H^+, Ca(OH)_2]$  and  $NH_2OH.HCl$ . (1984 - 2 Marks)
  - aniline to chlorobenzene (1985 - 1 Mark)
  - benzaldehyde to cyanobenzene. (in not more than 6 steps) (1986 - 2 Marks)
  - toluene to *m*-nitrobenzoic acid? (1987 - 1 Mark)
  - 4-nitroaniline to 1, 2, 3-tribromobenzene. (1990 - 2 Marks)
  - p*-bromonitrobenzene from benzene in two steps. (1993 - 2 Marks)
  - 4-nitrobenzaldehyde from benzene. (1994 - 2 Marks)
  - benzamide from nitrobenzene (1994 - 2 Marks)
  - Aniline  $\longrightarrow$  Benzylamine (in 3 steps) (2000 - 3 Marks)

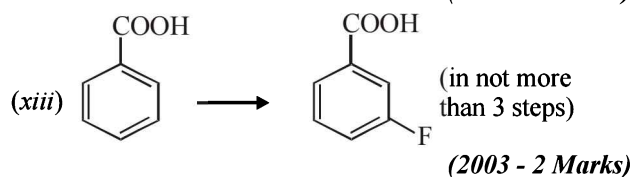

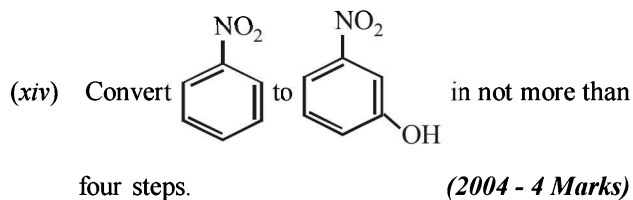

2. Give reasons for the following :

- (i) Cyclohexylamine is a stronger base than aniline. (1982 - 1 Mark)
- (ii) *o*-Nitrophenol is steam volatile whereas *p*-nitrophenol is not; (1985 - 1 Mark)
- (iii) Dimethylamine is a stronger base than trimethylamine. (1998 - 2 Marks)
- (iv) Nitrobenzene does not undergo Friedel-Crafts alkylation (1998 - 2 Marks)

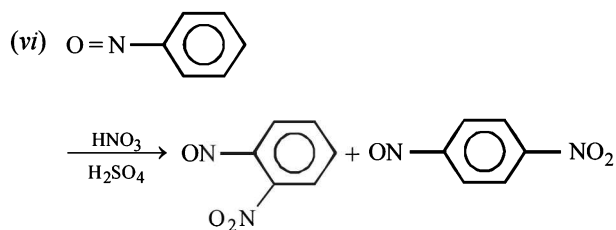
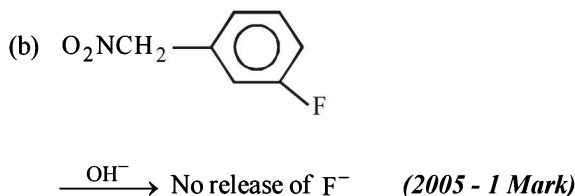
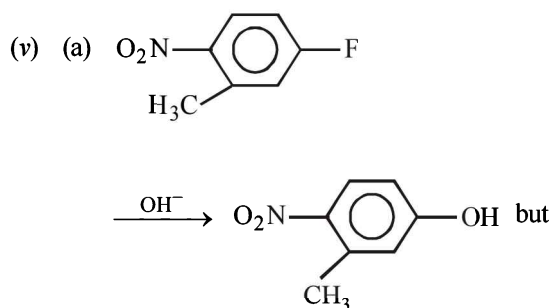

but

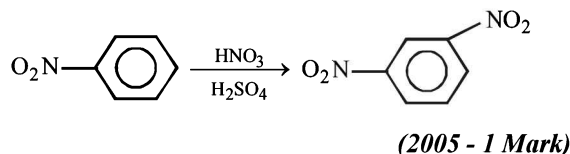

3. Arrange the following :

- (i) *p*-toluidine, *N,N*-dimethyl-*p*-toluidine, *p*-nitroaniline, aniline in increasing basicity (1986 - 1 Mark)
- (ii) methylamine, dimethylamine, aniline, *N*-methylaniline in increasing order of base strength. (1988 - 1 Mark)

4. Complete the following with appropriate structures :

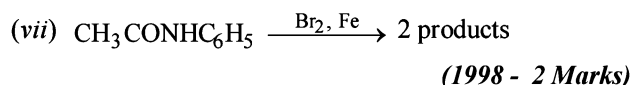
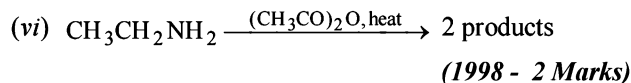
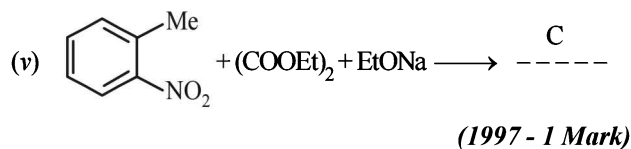
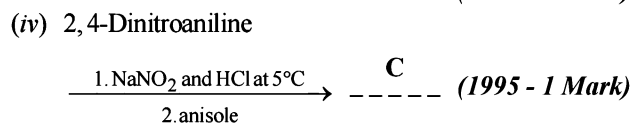
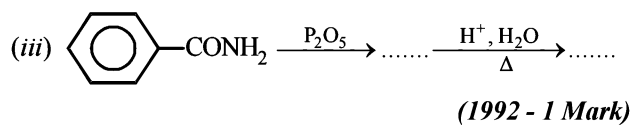
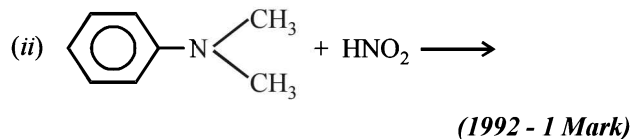
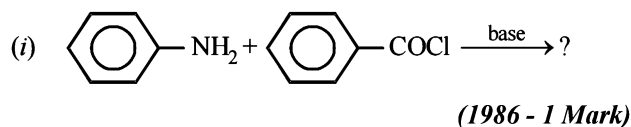

5. Write balanced equations for the following reaction :

Acetamide is reacted with bromine in the presence of potassium hydroxide. (1987 - 1 Mark)

6. Give a chemical test and the reagents used to distinguish between the following pair of compounds : Ethylamine and diethylamine. (1988 - 1 Mark)

7. An organic compound A, containing C, H, N and O, on analysis gives 49.32% carbon, 9.59% hydrogen and 19.18% nitrogen. A on boiling with NaOH gives off  $\text{NH}_3$  and a salt which on acidification gives a monobasic nitrogen free acid B. The silver salt of B contains 59.67% silver. Deduce the structures of A and B. (1988 - 3 Marks)

8. A mixture of two aromatic compounds A and B was separated by dissolving a chloroform followed by extraction with aqueous KOH solution. The organic layer containing compound A, when heated with alcoholic solution of KOH produced a compound C ( $\text{C}_7\text{H}_5\text{N}$ ) associated with an unpleasant odour. The alkaline aqueous layer on the other hand, when heated with chloroform and then acidified gave a mixture of two isomeric compounds D and E of molecular formula  $\text{C}_7\text{H}_6\text{O}_2$ . Identify the compounds A, B, C, D, E and write their structures. (1990 - 4 Marks)

9. A basic, volatile nitrogen compound gave a foul smelling gas when treated with chloroform and alcoholic potash. A 0.295 g sample of the substance, dissolved in aq. HCl and

treated with  $\text{NaNO}_2$  solution at  $0^\circ\text{C}$ , liberated a colorless, odourless gas whose volume corresponded to 112 ml at STP. After the evolution of the gas was complete, the aqueous solution was distilled to give an organic liquid which did not contain nitrogen and which on warming with alkali and iodine gave a yellow precipitate. Identify the original substance. Assume that it contains one N atom per molecule.

(1993 - 4 Marks)

10. Identify the major product in the following reactions :

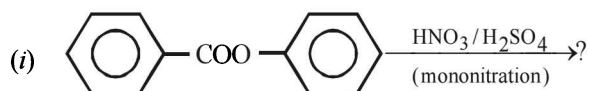

(1993 - 1 Mark)

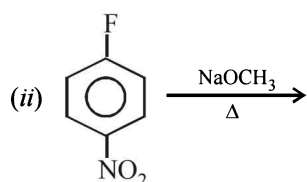

(2000 - 1 Mark)

15. Complete the following reaction with appropriate reagents :

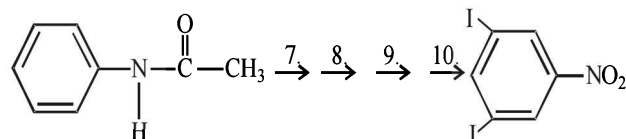

(1999 - 4 Marks)

16. Explain briefly the formation of the products giving the structures of the intermediates.

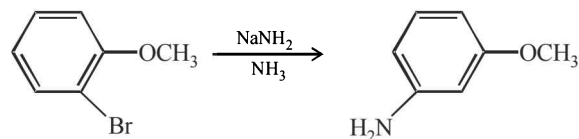

(1999 - 2 Marks)

17. How would you synthesise 4-methoxyphenol from bromobenzene in NOT more than five steps? State clearly the reagents used in each step and show the structures of the intermediate compounds in your synthetic scheme.

(2001 - 5 Marks)

18. Write structures of the products A, B, C, D and E in the following scheme.

(2002 - 5 Marks)

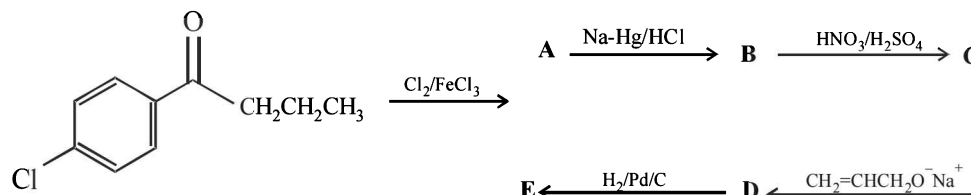

19. There is a solution of *p*-hydroxybenzoic acid and *p*-aminobenzoic acid. Discuss one method by which we can separate them and also write down the confirmatory tests of the functional groups present.

(2003 - 4 Marks)

20. Identify (A) to (D) in the following series of reactions.

(2004 - 4 Marks)

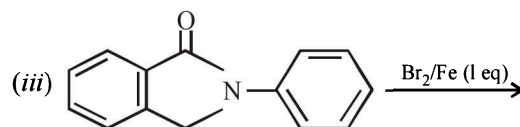
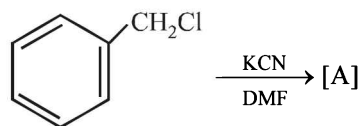

(2000 - 1 Mark)

11. Identify, A ( $\text{C}_3\text{H}_9\text{N}$ ) which reacts with benzenesulphonyl chloride to give a solid, insoluble in alkali.

(1993 - 1 Mark)

12. Write the structure of the foul-smelling compound obtained when aniline is treated with chloroform in the presence of KOH.

(1996 - 1 Mark)

13. Acetophenone on reaction with hydroxylamine hydrochloride can produce two isomeric oximes. Write structures of the oximes.

(1997 - 2 Marks)

14. Compound A ( $\text{C}_8\text{H}_8\text{O}$ ) on treatment with  $\text{NH}_2\text{OH} \cdot \text{HCl}$  gives B and C. B and C rearrange to give D and E, respectively, on treatment with acid. B, C, D and E are all isomers of molecular formula ( $\text{C}_8\text{H}_9\text{NO}$ ). When D is boiled with alcoholic KOH an oil F ( $\text{C}_6\text{H}_7\text{N}$ ) separates out. F reacts rapidly with  $\text{CH}_3\text{COCl}$  to give back D. On the other hand, E on boiling with alkali followed by acidification gives a white solid G ( $\text{C}_7\text{H}_6\text{O}_2$ ). Identify A-G

(1999 - 7 Marks)

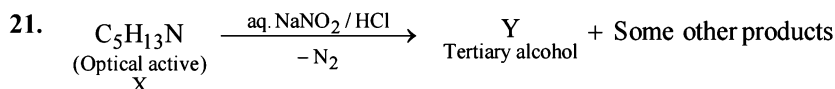
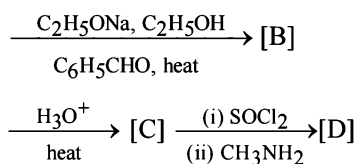

(2005 - 4 Marks)

- Identify (X) and (Y)
- Is (Y) optically active?
- Give structure(s) of intermediate(s), if any, in the formation of (Y) from (X).

## F Match the Following

**DIRECTIONS (Q. No.1):** Each question contains statements given in two columns, which have to be matched. The statements in Column-I are labelled A, B, C and D, while the statements in Column-II are labelled p, q, r, s and t. Any given statement in Column-I can have correct matching with ONE OR MORE statement(s) in Column-II. The appropriate bubbles corresponding to the answers to these questions have to be darkened as illustrated in the following example :

If the correct matches are A-p, s and t; B-q and r; C-p and q; and D-s then the correct darkening of bubbles will look like the given.

	p	q	r	s	t
A	<input checked="" type="radio"/>	<input type="radio"/>	<input type="radio"/>	<input checked="" type="radio"/>	<input checked="" type="radio"/>
B	<input type="radio"/>	<input checked="" type="radio"/>	<input checked="" type="radio"/>	<input type="radio"/>	<input type="radio"/>
C	<input checked="" type="radio"/>	<input checked="" type="radio"/>	<input type="radio"/>	<input type="radio"/>	<input type="radio"/>
D	<input type="radio"/>	<input type="radio"/>	<input type="radio"/>	<input checked="" type="radio"/>	<input type="radio"/>

1. Match each of the compounds in **Column I** with its characteristic reaction(s) in **Column II**.

(2009)

Column I	Column II
(A) $\text{CH}_3\text{CH}_2\text{CH}_2\text{CN}$	(p) Reduction with Pd-C/H <sub>2</sub>
(B) $\text{CH}_3\text{CH}_2\text{OCOCH}_3$	(q) Reduction with SnCl <sub>2</sub> /HCl
(C) $\text{CH}_3\text{-CH=CH-CH}_2\text{OH}$	(r) Development of foul smell on treatment with chloroform and alcoholic KOH
(D) $\text{CH}_3\text{CH}_2\text{CH}_2\text{CH}_2\text{NH}_2$	(s) Reduction with diisobutylaluminium hydride (DIBAL-H)
	(t) Alkaline hydrolysis

**DIRECTIONS (Q. No. 2) :** Match the four starting materials (P, Q, R, S) given in List-I with the corresponding reaction schemes (I, II, III, IV) provided in List-II and select the correct answer using the code given below the lists.

2. List - I List - II (JEE Adv. 2014)

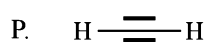

1. Scheme I

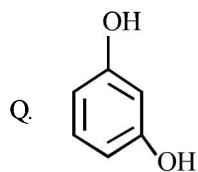
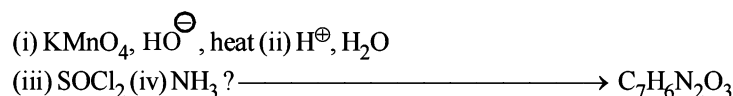

2. Scheme II

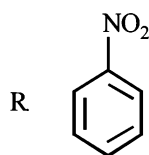
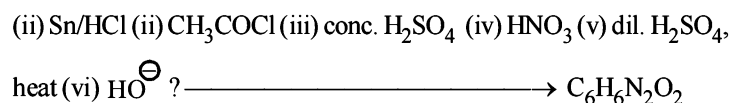

3. Scheme III

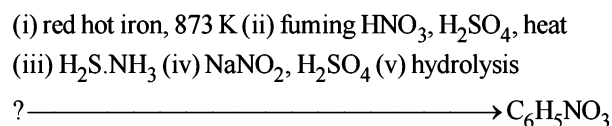



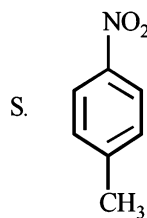

## 4. Scheme IV

(i) conc.  $\text{H}_2\text{SO}_4$ ,  $60^\circ\text{C}$ (ii) conc.  $\text{HNO}_3$ , conc.  $\text{H}_2\text{SO}_4$ (iii) dil.  $\text{H}_2\text{SO}_4$ , heat?  $\longrightarrow \text{C}_6\text{H}_5\text{NO}_4$ 

Code:

	P	Q	R	S
(a)	1	4	2	3
(b)	3	1	4	2
(c)	3	4	2	1
(d)	4	1	3	2

## G Comprehension Based Questions

## PASSAGE - 1

The conversion of an amide to an amine with one carbon atom less by the action of alkaline hydrohalite is known as Hofmann bromamide degradation.

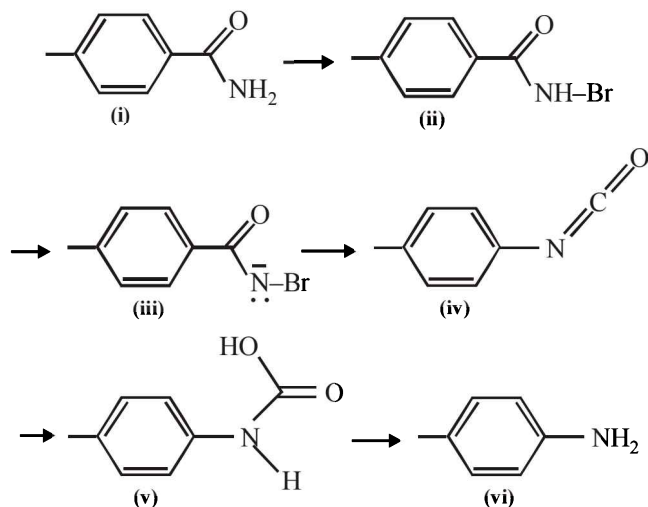

In this reaction,  $\text{RCONHBr}$  is formed from which the reaction has derived its name. Hofmann reaction is accelerated if the migrating group is more electron-releasing. Hofmann degradation reaction is an intramolecular reaction.

- How can the conversion of (i) to (ii) be brought about?  
(2006 - 5M, -2)
  - KBr
  - KBr +  $\text{CH}_3\text{ONa}$
  - KBr + KOH
  - $\text{Br}_2$  + KOH
- Which is the rate determining step in Hofmann bromamide degradation?  
(2006 - 5M, -2)
  - Formation of (i)
  - Formation of (ii)
  - Formation of (iii)
  - Formation of (iv)
- What are the constituent amines formed when the mixture of (i) and (ii) undergoes Hofmann bromamide degradation?  
(2006 - 5M, -2)

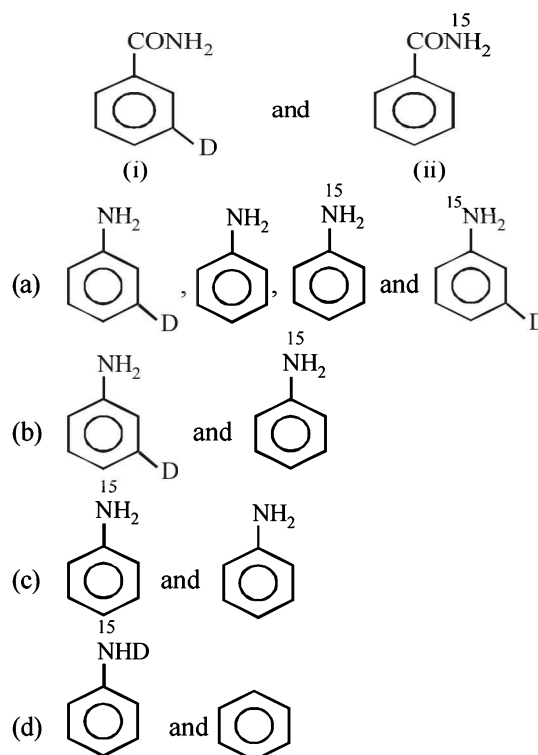

## PASSAGE - 2

Treatment of compound O with  $\text{KMnO}_4/\text{H}^+$  gave P, which on heating with ammonia gave Q. The compound Q on treatment with  $\text{Br}_2/\text{NaOH}$  produced R. On strong heating, Q gave S, which on further treatment with ethyl 2-bromopropanoate in the presence of KOH followed by acidification, gave a compound T.  
(JEE Adv. 2016)

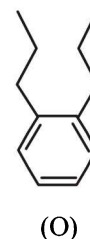

4. The compound R is

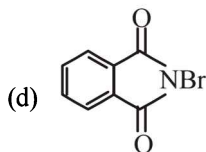
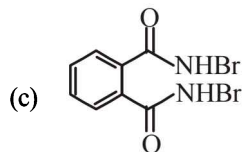
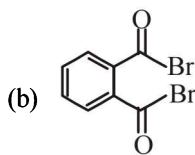
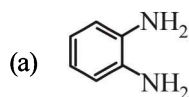

5. The compound T is

(a) glycine

(b) alanine

(c) valine

(d) serine

### H Assertion & Reason Type Questions

Read the following Statement-1 (Assertion) and Statement -2 (Reason) and answer as per the options given below :

- (a) Statement-1 is True, Statement-2 is True; Statement-2 is a correct explanation for Statement-1.  
 (b) Statement-1 is True, Statement-2 is True; Statement-2 is NOT a correct explanation for Statement-1  
 (c) Statement-1 is True, Statement-2 is False  
 (d) Statement-1 is False, Statement-2 is True

1. **Statement - 1:** *p*-Nitrophenol is a stronger acid than *o*-nitrophenol.

**Statement - 2:** Intramolecular hydrogen bonding makes the *o*-isomer weaker than the *p*-isomer. (1989 - 2 Marks)

2. **Statement - 1:** Benzonitrile is prepared by the reaction of chlorobenzene with potassium cyanide.

**Statement - 2:** Cyanide (CN<sup>-</sup>) is a strong nucleophile.

(1998 - 2 Marks)

3. **Statement - 1:** In strongly acidic solutions, aniline becomes more reactive towards electrophilic reagents.



**Statement - 2:** The amino group being completely protonated in strongly acidic solution, the lone pair of electrons on the nitrogen is no longer available for resonance. (2001S)

4. **Statement - 1:** Aniline on reaction with NaNO<sub>2</sub>/HCl at 0°C followed by coupling with β-naphthol gives a dark blue precipitate.

and

**Statement - 2:** The colour of the compound formed in the reaction of aniline with NaNO<sub>2</sub>/HCl at 0°C followed by coupling with β-naphthol is due to the extended conjugation. (2008)

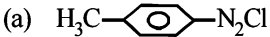
## Section-B JEE Main / AIEEE

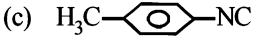
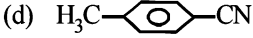
- When primary amine reacts with chloroform in ethanolic KOH then the product is [2002]
  - an isocyanide
  - an aldehyde
  - a cyanide
  - an alcohol.
- The reaction of chloroform with alcoholic KOH and p-toluidine forms [2003]
  - 
  - 
  - 
  - 
- The correct order of increasing basic nature for the bases  $\text{NH}_3$ ,  $\text{CH}_3\text{NH}_2$  and  $(\text{CH}_3)_2\text{NH}$  is [2003]
  - $(\text{CH}_3)_2\text{NH} < \text{NH}_3 < \text{CH}_3\text{NH}_2$
  - $\text{NH}_3 < \text{CH}_3\text{NH}_2 < (\text{CH}_3)_2\text{NH}$
  - $\text{CH}_3\text{NH}_2 < (\text{CH}_3)_2\text{NH} < \text{NH}_3$
  - $\text{CH}_3\text{NH}_2 < \text{NH}_3 < (\text{CH}_3)_2\text{NH}$
- Ethyl isocyanide on hydrolysis in acidic medium generates [2003]
  - propanoic acid and ammonium salt
  - ethanoic acid and ammonium salt
  - methylamine salt and ethanoic acid
  - ethylamine salt and methanoic acid
- Which one of the following methods is neither meant for the synthesis nor for separation of amines? [2005]
  - Curtius reaction
  - Wurtz reaction
  - Hofmann method
  - Hinsberg method
- Amongst the following the most basic compound is [2005]
  - p-nitroaniline
  - acetanilide
  - aniline
  - benzylamine
- An organic compound having molecular mass 60 is found to contain C = 20%, H = 6.67% and N = 46.67% while rest is oxygen. On heating it gives  $\text{NH}_3$  alongwith a solid residue. The solid residue give violet colour with alkaline copper sulphate solution. The compound is [2005]
  - $\text{CH}_3\text{CH}_2\text{CONH}_2$
  - $(\text{NH}_2)_2\text{CO}$
  - $\text{CH}_3\text{CONH}_2$
  - $\text{CH}_3\text{NCO}$
- Which one of the following is the strongest base in aqueous solution? [2007]
  - Methylamine
  - Trimethylamine
  - Aniline
  - Dimethylamine.
- In the chemical reaction,
 
$$\text{CH}_3\text{CH}_2\text{NH}_2 + \text{CHCl}_3 + 3\text{KOH} \rightarrow (\text{A}) + (\text{B}) + 3\text{H}_2\text{O}$$
 the compounds (A) and (B) are respectively [2007]
  - $\text{C}_2\text{H}_5\text{NC}$  and  $3\text{KCl}$
  - $\text{C}_2\text{H}_5\text{CN}$  and  $3\text{KCl}$
  - $\text{CH}_3\text{CH}_2\text{CONH}_2$  and  $3\text{KCl}$
  - $\text{C}_2\text{H}_5\text{NC}$  and  $\text{K}_2\text{CO}_3$ .
- In the chemical reactions,
 

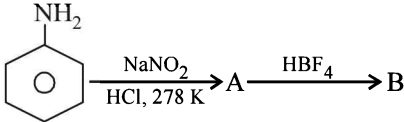

 the compounds 'A' and 'B' respectively are [2010]
  - nitrobenzene and fluorobenzene
  - phenol and benzene
  - benzene diazonium chloride and fluorobenzene
  - nitrobenzene and chlorobenzene
- A compound with molecular mass 180 is acylated with  $\text{CH}_3\text{COCl}$  to get a compound with molecular mass 390. The number of amino groups present per molecule of the former compound is : [JEE M 2013]
  - 2
  - 5
  - 4
  - 6
- An organic compound A upon reacting with  $\text{NH}_3$  gives B. On heating B gives C. C in presence of KOH reacts with  $\text{Br}_2$  to given  $\text{CH}_3\text{CH}_2\text{NH}_2$ . A is : [JEE M 2013]
  - $\text{CH}_3\text{COOH}$
  - $\text{CH}_3\text{CH}_2\text{CH}_2\text{COOH}$
  - $\text{CH}_3 - \underset{\text{CH}_3}{\text{CH}} - \text{COOH}$
  - $\text{CH}_3\text{CH}_2\text{COOH}$
- The gas leaked from a storage tank of the Union Carbide plant in Bhopal gas tragedy was : [JEE M 2013]
  - Methyl isocyanate
  - Methylamine
  - Ammonia
  - Phosgene
- On heating an aliphatic primary amine with chloroform and ethanolic potassium hydroxide, the organic compound formed is: [JEE M 2014]
  - an alkanol
  - an alkanediol
  - an alkyl cyanide
  - an alkyl isocyanide
- Considering the basic strength of amines in aqueous solution, which one has the smallest  $pK_b$  value? [JEE M 2014]
  - $(\text{CH}_3)_2\text{NH}$
  - $\text{CH}_3\text{NH}_2$
  - $(\text{CH}_3)_3\text{N}$
  - $\text{C}_6\text{H}_5\text{NH}_2$

16. In the reaction

[JEE M 2015]

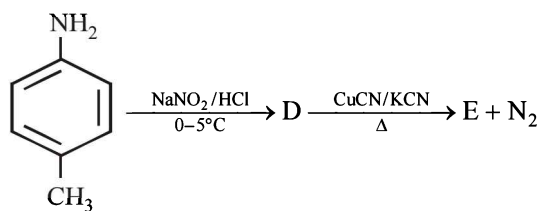

the product E is :

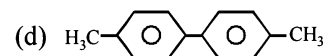
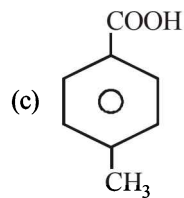
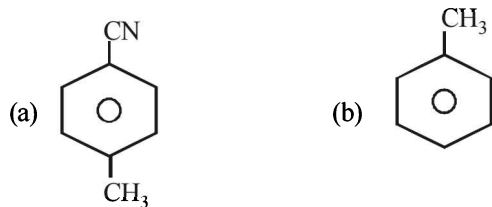

17. In the Hofmann bromamide degradation reaction, the number of moles of NaOH and Br<sub>2</sub> used per mole of amine produced are :

[JEE M 2016]

- (a) Two moles of NaOH and two moles of Br<sub>2</sub>.  
 (b) Four moles of NaOH and one mole of Br<sub>2</sub>.  
 (c) One mole of NaOH and one mole of Br<sub>2</sub>.  
 (d) Four moles of NaOH and two moles of Br<sub>2</sub>.

## CHAPTER

## 22

# Carbohydrates, Amino Acids, Polymers & Miscellaneous

## Match the Following

## Section-A

## JEE Advanced/ IIT-JEE

## C MCQs with One Correct Answer

- The pair of compounds in which both the compounds give positive test with Tollen's reagent is (2004S)
  - Glucose and Sucrose
  - Fructose and Sucrose
  - Acetophenone and Hexanal
  - Glucose and Fructose
- The two forms of D-glucopyranose obtained from the solution of D-glucose are called (2005S)
  - Isomers
  - Anomers
  - Epimers
  - Enantiomers
- Cellulose upon acetylation with excess acetic anhydride/ $H_2SO_4$  (catalytic) gives cellulose triacetate whose structure is (2008S)

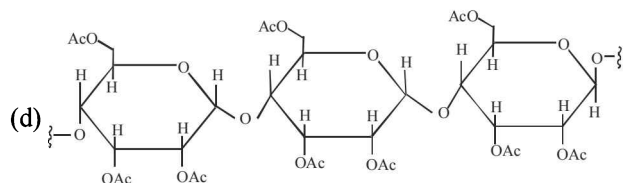
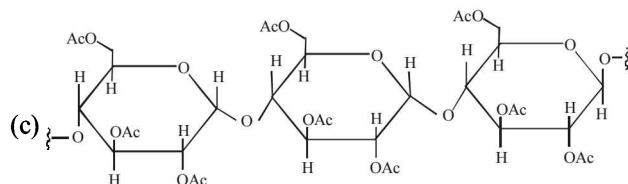
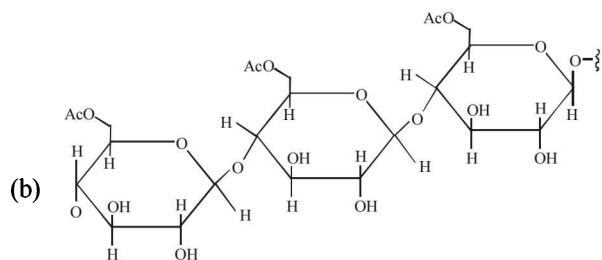
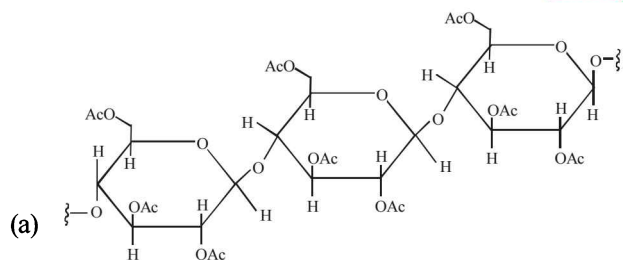

- Among cellulose, poly (vinyl chloride), nylon and natural rubber, the polymer in which the intermolecular force of attraction is weakest is (2009S)

- Nylon
- Poly (vinyl chloride)
- Cellulose
- Natural Rubber

- The correct statement about the following disaccharide is

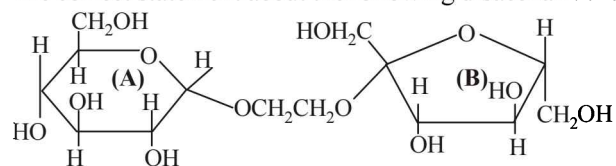

(2010)

- Ring (A) is pyranose with  $\alpha$ -glycosidic link
- Ring (A) is furanose with  $\alpha$ -glycosidic link
- Ring (B) is furanose with  $\alpha$ -glycosidic link
- Ring (B) is pyranose with  $\beta$ -glycosidic link

- The following carbohydrate is (2011-II)

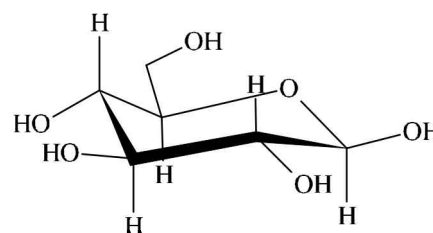

- a ketohexose
- an aldohexose
- an  $\alpha$ -furanose
- an  $\alpha$ -pyranose

- On complete hydrogenation, natural rubber produces
  - ethylene-propylene copolymer (JEE Adv. 2016)
  - vulcanised rubber
  - polypropylene
  - polybutylene

## D MCQs with One or More Than One Correct

- The correct statement(s) about the following sugars X and Y is(are) (2009S)

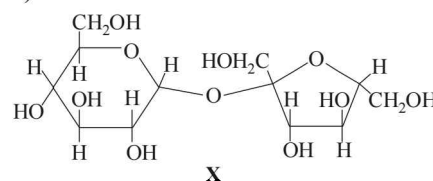

X

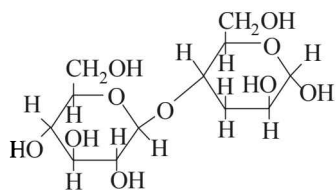

- (a) X is a reducing sugar and Y is a non-reducing sugar  
 (b) X is a non-reducing sugar and Y is a reducing sugar  
 (c) The glucosidic linkages in X and Y are  $\alpha$  and  $\beta$ , respectively  
 (d) The glucosidic linkages in X and Y are  $\beta$  and  $\alpha$ , respectively
2. The correct functional group X and the reagent/reaction conditions Y in the following scheme are (2011-II)

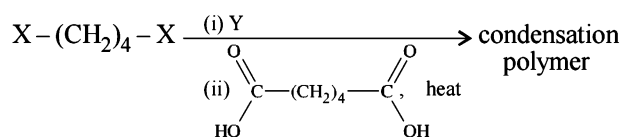

- (a)  $X = \text{COOCH}_3$ ,  $Y = \text{H}_2/\text{Ni}/\text{heat}$   
 (b)  $X = \text{CONH}_2$ ,  $Y = \text{H}_2/\text{Ni}/\text{heat}$   
 (c)  $X = \text{CONH}_2$ ,  $Y = \text{Br}_2/\text{NaOH}$   
 (d)  $X = \text{CN}$ ,  $Y = \text{H}_2/\text{Ni}/\text{heat}$
3. The structure of D-(+)-glucose is (JEE Adv. 2015)

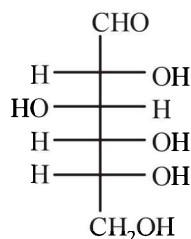

The structure of L-(-)-glucose is

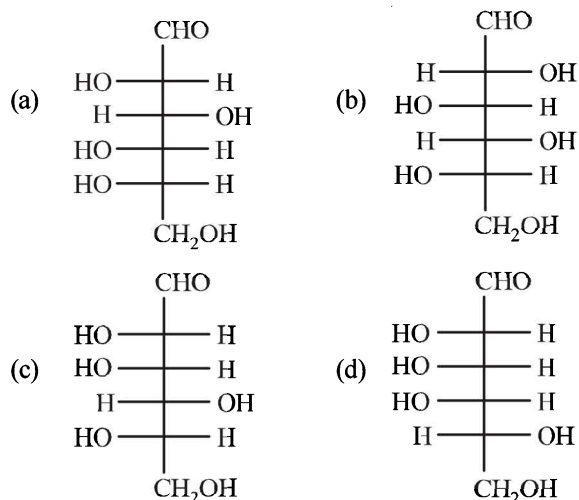

4. For 'invert sugar', the correct statement(s) is(are)  
 (Given : specific rotations of (+) -sucrose, (+)-maltose, L-(-)-glucose and L-(+) fructose in aqueous solution are  $+66^\circ$ ,  $+140^\circ$ ,  $-52^\circ$  and  $+92^\circ$ , respectively) (JEE Adv. 2016)
- (a) 'invert sugar' is prepared by acid catalyzed hydrolysis of maltose

- (b) 'invert sugar' is an equimolar mixture of D-(+)-glucose and D-(-)-fructose  
 (c) specific rotation of 'invert sugar' is  $-20^\circ$   
 (d) on reaction with  $\text{Br}_2$  water, 'invert sugar' forms saccharic acid as one of the products

## E Subjective Problems

1. Give the structures of the products in each of the following reactions. (2000 - 4 Marks)

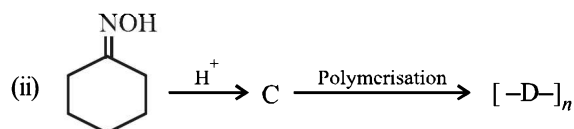
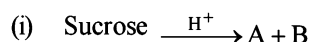

2. Write the structures of alanine at pH = 2 and pH = 10. (2000 - 2 Marks)
3. Aspartame, an artificial sweetener, is a peptide and has the following structure : (2001 - 5 Marks)

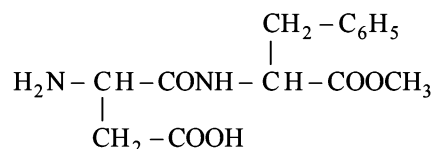

- (i) Identify the four functional groups.  
 (ii) Write the zwitterionic structure.  
 (iii) Write the structures of the amino acids obtained from the hydrolysis of aspartame.  
 (iv) Which of the two amino acids is more hydrophobic?
4. Following two amino acids lysine and glutamine form dipeptide linkage. What are two possible dipeptides? (2003 - 2 Marks)

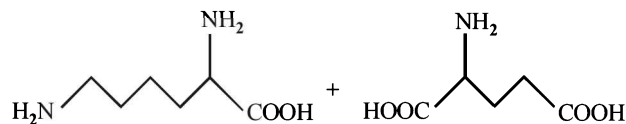

5. The Fisher projection of D-glucose is drawn below. (2004 - 2 Marks)

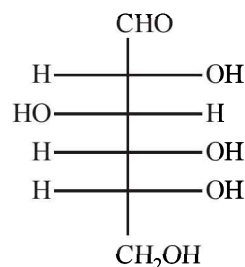

- (i) Draw the Fisher projection of L-glucose.  
 (ii) Give the reaction of L-glucose with Tollen's reagent
6. Which of the following will reduce Tollen's reagent? Explain. (2005 - 2 Marks)

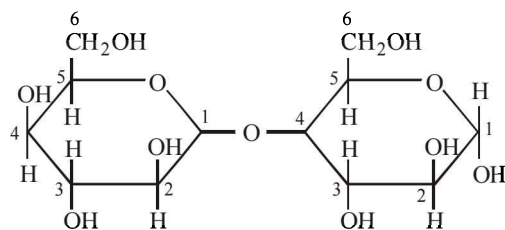

A

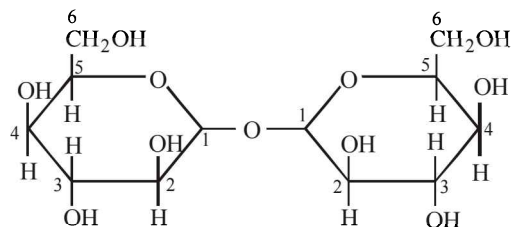

B

### F Match the Following

Each question contains statements given in two columns, which have to be matched. The statements in Column-I are labelled A, B, C and D, while the statements in Column-II are labelled p, q, r, s and t. Any given statement in Column-I can have correct matching with ONE OR MORE statement(s) in Column-II. The appropriate bubbles corresponding to the answers to these questions have to be darkened as illustrated in the following example :

If the correct matches are A-p, s and t; B-q and r; C-p and q; and D-s then the correct darkening of bubbles will look like the given.

	p	q	r	s	t
A	<input checked="" type="checkbox"/>	<input checked="" type="checkbox"/>	<input checked="" type="checkbox"/>	<input checked="" type="checkbox"/>	<input checked="" type="checkbox"/>
B	<input checked="" type="checkbox"/>	<input checked="" type="checkbox"/>	<input checked="" type="checkbox"/>	<input type="checkbox"/>	<input type="checkbox"/>
C	<input checked="" type="checkbox"/>	<input checked="" type="checkbox"/>	<input type="checkbox"/>	<input type="checkbox"/>	<input type="checkbox"/>
D	<input type="checkbox"/>	<input type="checkbox"/>	<input type="checkbox"/>	<input checked="" type="checkbox"/>	<input type="checkbox"/>

1. Match the chemical substances in **Column I** with type of polymers/type of bonds in **Column II**. (2007)

#### Column I

- (A) cellulose  
(B) nylon-6, 6  
(C) protein  
(D) sucrose

#### Column II

- (p) Natural polymer  
(q) Synthetic polymer  
(r) Amide linkage  
(s) Glycoside linkage

2. Match the reaction in Column I with appropriate options in Column II. (2010)

#### Column-I

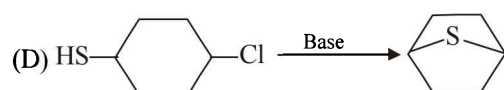
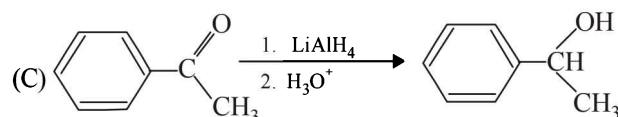
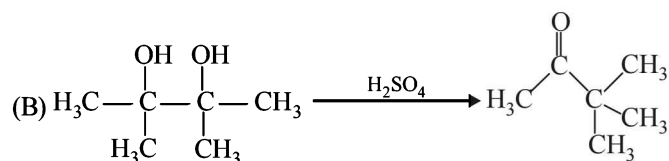
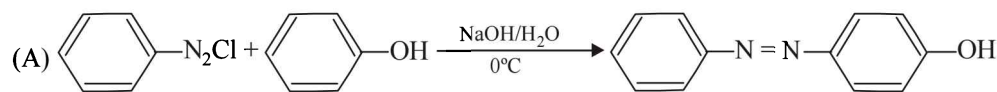

#### Column-II

(p) Racemic mixture

(q) Addition reaction

(r) Substitution reaction

(s) Coupling reaction

(t) Carbocation intermediate

### I Assertion & Reason Type Questions

1. This question contains Statement-1 (Assertion) and Statement-2 (Reason) and has 4 choices (a), (b), (c) and (d) out of which ONLY ONE is correct.

**Statement-1 :** Glucose gives a reddish-brown precipitate with Fehling's solution.

because

**Statement-2 :** Reaction of glucose with Fehling's solution give CuO and gluconic acid. (2007)

- (a) Statement-1 is True, Statement-2 is True; Statement-2 is a correct explanation for Statement-1  
 (b) Statement-1 is True, Statement-2 is True; Statement-2 is not a correct explanation for Statement-1  
 (c) Statement-1 is True, Statement-2 is False  
 (d) Statement-1 is False, Statement-2 is True.

### I Integer Value Correct Type

1. The total number of basic groups in the following form of lysine is (2010)

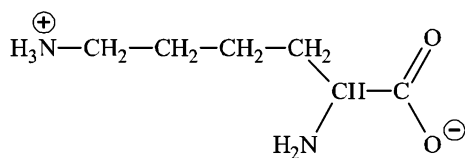

2. A decapeptide (Mol. wt. 796) on complete hydrolysis gives glycine (Mol. wt. 75), alanine and phenylalanine. Glycine contributes 47.0% to the total weight of the hydrolysed products. The number of glycine units present in the decapeptide is (2011)
3. When the following aldohexose exists in its D-configuration, the total number of stereoisomers in its pyranose form is : (2012)
- $$\text{CHO}-\text{CH}_2-\text{CHOH}-\text{CHOH}-\text{CHOH}-\text{CH}_2\text{OH}$$

4. The substituents  $R_1$  and  $R_2$  for nine peptides are listed in the table given below. How many of these peptides are positively charged at  $\text{pH} = 7.0$ ? (2012)

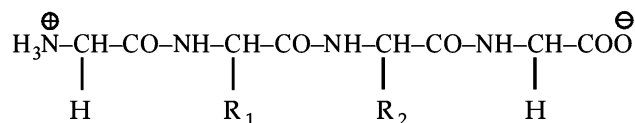

Peptide	$R_1$	$R_2$
I	H	H
II	H	$\text{CH}_3$
III	$\text{CH}_2\text{COOH}$	H
IV	$\text{CH}_2\text{CONH}_2$	$(\text{CH}_2)_4\text{NH}_2$
V	$\text{CH}_2\text{CONH}_2$	$\text{CH}_2\text{CONH}_2$
VI	$(\text{CH}_2)_4\text{NH}_2$	$(\text{CH}_2)_4\text{NH}_2$
VII	$\text{CH}_2\text{COOH}$	$\text{CH}_2\text{CONH}_2$
VIII	$\text{CH}_2\text{OH}$	$(\text{CH}_2)_4\text{NH}_2$
IX	$(\text{CH}_2)_4\text{NH}_2$	$\text{CH}_3$

5. A tetrapeptide has  $-\text{COOH}$  group on alanine. This produces glycine (Gly), valine (Val), phenyl alanine (Phe) and alanine (Ala), on complete hydrolysis. For this tetrapeptide, the number of possible sequences (primary structures) with  $-\text{NH}_2$  group attached to a chiral center is (JEE Adv. 2013)
6. The total number of *distinct naturally occurring amino acids* obtained by complete acidic hydrolysis of the peptide shown below is (JEE Adv. 2014)

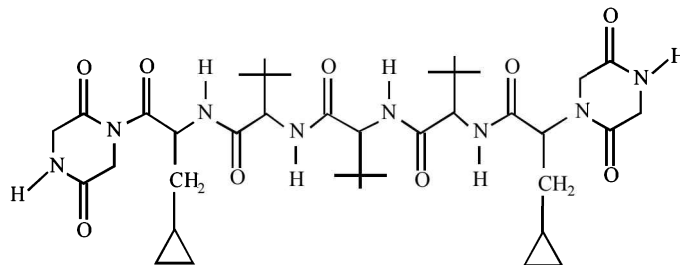

## Section-B JEE Main / AIEEE

1. Polymer formation from monomers starts by [2002]  
 (a) condensation reaction between monomers  
 (b) coordinate reaction between monomers  
 (c) conversion of monomer to monomer ions by protons  
 (d) hydrolysis of monomers.
2. RNA is different from DNA because RNA contains [2002]  
 (a) ribose sugar and thymine  
 (b) ribose sugar and uracil  
 (c) deoxyribose sugar and thymine  
 (d) deoxyribose sugar and uracil.

3. The compound is used as [2002]  
 (a) antiseptic (b) antibiotic  
 (c) analgesic (d) pesticide.
4. Which of the following could act as a propellant for rockets? [2003]  
 (a) Liquid oxygen + liquid argon  
 (b) Liquid hydrogen + liquid oxygen  
 (c) Liquid nitrogen + liquid oxygen  
 (d) Liquid hydrogen + liquid nitrogen



**Carbohydrates, Amino Acids, Polymers & Miscellaneous Match the Following**

5. Nylon threads are made of [2003]  
 (a) polyester polymer (b) polyamide polymer  
 (c) polyethylene polymer (d) polyvinyl polymer
6. Complete hydrolysis of cellulose gives [2003]  
 (a) D-ribose (b) D-glucose  
 (c) L-glucose (d) D-fructose
7. The reason for double helical structure of DNA is operation of [2003]  
 (a) dipole-dipole interaction  
 (b) hydrogen bonding  
 (c) electrostatic attractions (d) van der Waals' forces
8. Which base is present in RNA but not in DNA ? [2004]  
 (a) Guanine (b) Cytosine  
 (c) Uracil (d) Thymine
9. Insulin production and its action in human body are responsible for the level of diabetes. This compound belongs to which of the following categories ? [2004]  
 (a) An enzyme (b) A hormone  
 (c) A co-enzyme (d) An antibiotic
10. The smog is essentially caused by the presence of [2004]  
 (a) Oxides of sulphur and nitrogen  
 (b)  $O_2$  and  $N_2$   
 (c)  $O_2$  and  $O_3$  (d)  $O_3$  and  $N_2$
11. Which of the following is a polyamide? [2005]  
 (a) Bakelite (b) Terylene  
 (c) Nylon-66 (d) Teflon
12. Which one of the following types of drugs reduces fever ? [2005]  
 (a) Tranquiliser (b) Antibiotic  
 (c) Antipyretic (d) Analgesic
13. In both DNA and RNA, heterocyclic base and phosphate ester linkages are at – [2005]  
 (a)  $C'_5$  and  $C'_1$  respectively of the sugar molecule  
 (b)  $C'_1$  and  $C'_5$  respectively of the sugar molecule  
 (c)  $C'_2$  and  $C'_5$  respectively of the sugar molecule  
 (d)  $C'_5$  and  $C'_2$  respectively of the sugar molecule
14. Which of the following is fully fluorinated polymer? [2005]  
 (a) PVC (b) Thiokol  
 (c) Teflon (d) Neoprene
15. The term anomers of glucose refers to [2006]  
 (a) enantiomers of glucose  
 (b) isomers of glucose that differ in configuration at carbon one (C-1)  
 (c) isomers of glucose that differ in configurations at carbons one and four (C-1 and C-4)  
 (d) a mixture of (D)-glucose and (L)-glucose
16. The pyrimidine bases present in DNA are [2006]  
 (a) cytosine and thymine (b) cytosine and uracil  
 (c) cytosine and adenine (d) cytosine and guanine
17. The secondary structure of a protein refers to [2007]  
 (a) fixed configuration of the polypeptide backbone  
 (b)  $\alpha$  – helical backbone  
 (c) hydrophobic interactions  
 (d) sequence of  $\alpha$  – amino acids.
18. Identify the wrong statement in the following: [2008]  
 (a) Chlorofluorocarbons are responsible for ozone layer depletion  
 (b) Greenhouse effect is responsible for global warming  
 (c) Ozone layer does not permit infrared radiation from the sun to reach the earth  
 (d) Acid rain is mostly because of oxides of nitrogen and sulphur
19. Bakelite is obtained from phenol by reacting with [2008]  
 (a)  $(CH_2OH)_2$  (b)  $CH_3CHO$   
 (c)  $CH_3COCH_3$  (d)  $HCHO$
20.  $\alpha$  - D-(+)-glucose and  $\beta$ -D-(+)-glucose are [2008]  
 (a) conformers (b) epimers  
 (c) anomers (d) enantiomers
21. Among the following substituted silanes the one which will give rise to cross linked silicone polymer on hydrolysis is [2008]  
 (a)  $R_4Si$  (b)  $RSiCl$   
 (c)  $R_2SiCl_2$  (d)  $R_3SiCl$
22. Buna-N synthetic rubber is a copolymer of: [2009]  
 (a)  $H_2C=CH-CH=CH_2$  and  $H_5C_6-CH=CH_2$   
 (b)  $H_2C=CH-CN$  and  $H_2C=CH-CH_2CH_2$   
 (c)  $H_2C=CH-CN$  and  $H_2C=CH-\underset{\substack{| \\ CH_3}}{C}=CH_2$   
 (d)  $H_2C=CH-\overset{\substack{| \\ Cl}}{C}=CH_2$  and  $H_2C=CH-CH=CH_2$
23. The two functional groups present in a typical carbohydrate are: [2009]  
 (a)  $-CHO$  and  $-COOH$  (b)  $>C=O$  and  $-OH$   
 (c)  $-OH$  and  $-CHO$  (d)  $-OH$  and  $-COOH$
24. Biuret test is **not** given by [2010]  
 (a) carbohydrates (b) polypeptides  
 (c) urea (d) proteins
25. The polymer containing strong intermolecular forces e.g. hydrogen bonding, is [2010]  
 (a) teflon (b) nylon 6, 6  
 (c) polystyrene (d) natural rubber

26. The presence or absence of hydroxyl group on which carbon atom of sugar differentiates RNA and DNA? [2011]  
(a) 1<sup>st</sup> (b) 2<sup>nd</sup>  
(c) 3<sup>rd</sup> (d) 4<sup>th</sup>
27. Which of the following compounds can be detected by Molisch's Test? [2012]  
(a) Nitro compounds (b) Sugars  
(c) Amines (d) Primary alcohols
28. The species which can best serve as an initiator for the cationic polymerization is : [2012]  
(a)  $\text{LiAlH}_4$  (b)  $\text{HNO}_3$   
(c)  $\text{AlCl}_3$  (d)  $\text{BaLi}$
29. Which one of the following statements is correct? [2012]  
(a) All amino acids except lysine are optically active  
(b) All amino acids are optically active  
(c) All amino acids except glycine are optically active  
(d) All amino acids except glutamic acids are optically active
30. Aspirin is known as : [2012]  
(a) Acetyl salicylic acid (b) Phenyl salicylate  
(c) Acetyl salicylate (d) Methyl salicylic acid
31. Synthesis of each molecule of glucose in photosynthesis involves : [JEE M 2013]  
(a) 18 molecules of ATP (b) 10 molecules of ATP  
(c) 8 molecules of ATP (d) 6 molecules of ATP
32. Which one is classified as a condensation polymer? [JEE M 2014]  
(a) Dacron (b) Neoprene  
(c) Teflon (d) Acrylonitrile
33. Which one of the following bases is **not** present in DNA? [JEE M 2014]  
(a) Quinoline (b) Adenine  
(c) Cytosine (d) Thymine
34. Which of the vitamins given below is water soluble? [JEE M 2015]  
(a) Vitamin E (b) Vitamin K  
(c) Vitamin C (d) Vitamin D
35. Which of the following compounds is not an antacid? [JEE M 2015]  
(a) Phenelzine (b) Ranitidine  
(c) Aluminium hydroxide (d) Cimetidine
36. Which polymer is used in the manufacture of paints and lacquers? [JEE M 2015]  
(a) Polypropene (b) Polyvinyl chloride  
(c) Bakelite (d) Glyptal
37. The concentration of fluoride, lead, nitrate and iron in a water sample from an underground lake was found to be 1000 ppb, 40 ppb, 100 ppm and 0.2 ppm, respectively. This water is unsuitable for drinking due to high concentration of: [JEE M 2016]  
(a) Nitrate (b) Iron  
(c) Fluoride (d) Lead
38. Which of the following is an anionic detergent? [JEE M 2016]  
(a) Cetyltrimethyl ammonium bromide.  
(b) Glyceryl oleate.  
(c) Sodium stearate.  
(d) Sodium lauryl sulphate.
39. Which of the following statements about low density polythene is **FALSE**? [JEE M 2016]  
(a) Its synthesis requires dioxygen or a peroxide initiator as a catalyst.  
(b) It is used in the manufacture of buckets, dust-bins etc.  
(c) Its synthesis requires high pressure.  
(d) It is a poor conductor of electricity.

## Miscellaneous – Match The following for IIT-JEE

- I** Each item from (i) to (x) given below indicates a reaction type, a process or a homologue. Match each of these items with the related phrase by writing the correct phrase in the corresponding vacant space given under each. The correct phrase must be picked only from those given below within brackets :

(Baeyer's process, Nucleophilic addition, Free radical substitution, Ostwald's process, Homologous pair, Cyanamide process, Electrophilic substitution, Homolytic addition, Thermite process, Nucleophilic substitution)

(1981 -  $1 \times 10 = 10$  Marks)

- (i) Cyclopropane, chlorine and light  
.....
- (ii) Welding  
.....
- (iii) Propanone and sodium bisulphite  
.....
- (iv) Production of ammonia  
.....
- (v) Chloromethane and methanol  
.....
- (vi) Ore purification  
.....
- (vii) Ethanal and methanal  
.....
- (viii) Benzene, nitric acid and sulphuric acid  
.....
- (ix) Production of nitric acid  
.....
- (x) Propene, hydrogen bromide and a peroxide catalyst  
.....

- II** Match the following, choosing one item from column X and one from column Y. An example is — for item No. (i) – (g)

(1982 - 3 Marks)

- |           | X   | Y                        |
|-----------|---|--------------------------|
| <b>A.</b> | (i) $\text{Hg}_2\text{Cl}_2$                            | (a) cassiterite          |
|           | (ii) $(\text{NaPO}_3)_n$                                | (b) lunar caustic        |
|           | (iii) $\text{NO}_3^-$                                   | (c) producer gas         |
|           | (iv) $\text{SnO}_2$                                     | (d) water softener       |
|           | (v) $\text{KCl.MgCl}_2.6\text{H}_2\text{O}$             | (e) brown ring test      |
|           | (vi) $\text{AgNO}_3$                                    | (f) carnallite           |
|           | (vii) $\text{CO} + \text{N}_2$                          | (g) calomel              |
| <b>B.</b> | (viii) pyrolysis of alkanes                             | (j) elimination reaction |
|           | (ix) benzene+chloroethane (+anhydrous $\text{AlCl}_3$ ) | (k) saponification       |
|           | (x) $\text{CH}_3\text{COOC}_2\text{H}_5 + \text{NaOH}$  | (l) Wurtz reaction       |
- (1982 - 3 Marks)

- (xi) preparation of alkanes (m) Friedel-Crafts reaction  
(xii) phenol +  $\text{CHCl}_3$  (NaOH) (n) Reimer-Tiemann reaction  
(xiii)  $\text{C}_2\text{H}_5\text{Br} + \text{alc. KOH}$  (o) cracking

**C.** (1982 - 2 Marks)

- (xiv) neutrons (p) Kohlrausch  
(xv) molecular speed (q) Vander Waals  
(xvi) intermolecular forces (r) Maxwell  
(xvii) conductance of ions (s) Chadwick

**D.** (1982 - 2 Marks)

- (xviii) mass spectrum (t) wave function  
(xix) x-ray spectrum (u) unpaired electrons  
(xx) paramagnetism (v) atomic number  
(xxi) orbitals (w) isotopes

- III** Match the following, choosing one item from column X and the appropriate item from column Y. Write down the matched pair on the answer script :

(1983 - 2 Marks)

**A.**

- (i) Decarboxylation (a) Addition reaction  
(ii) Ozonolysis (b) Soda lime  
(iii) Williamson's synthesis (c) Structure of alkene  
(iv) Dichloroethylene (d) Ether

**B.** (1983 - 2 Marks)

- (i) Luca's test (a) Phenol  
(ii) Neutral  $\text{FeCl}_3$  test (b) Glucose  
(iii) Dye test (c) Tertiary alcohol  
(iv) Tollen's test (d) Aniline

**C.** X Y (1983 - 2 Marks)

- (i) Al (a) Calamine  
(ii) Cu (b) Cryolite  
(iii) Mg (c) Malachite  
(iv) Zn (d) Carnallite

**D.** (1983 - 2 Marks)

- (i) Haber (a) Activation energy  
(ii) Graham (b) Diffusion of gases  
(iii) Arrhenius (c) Octet rule  
(iv) Lewis (d) Ammonia synthesis

- IV.** Write the matched set (of three) for each entry in column A:  
(1984 -  $1 \times 5 = 5$  Marks)

- | A                   | B                          | C                     |
|---------------------|----------------------------|-----------------------|
| (i) Asbestos        | (a) molecular sieve        | (1) air pollutant     |
| (ii) Fluorocarbons  | (b) paramagnetic           | (2) carcinogen        |
| (iii) Lithium metal | (c) refrigeration          | (3) fluorescent paint |
| (iv) Nitric oxide   | (d) reducing agent         | (4) electron donor    |
| (v) Zeolites        | (e) semi-conductor         | (5) ion exchanger     |
| (vi) Zinc oxide     | (f) silicates of (Ca + Mg) | (6) propellant        |

- V.** Match each item of the right hand column with an appropriate item in the left hand column for each of the following sections:  
(1985 -  $2\frac{1}{2} \times 4 = 10$  Marks)

- A.** (i) spinel (a)  $MgAl_2O_4$   
(ii) feldspar (b) PbCO  
(iii) cerussite (c)  $KAlSi_3O_8$   
(iv) malachite (d)  $MgSO_4 \cdot H_2O$   
(v) kisserite (e)  $Cu(OH)_2 \cdot CuCO_3$
- B.** (vi) liquid air (f) Deacon process  
(vii)  $Na_2CO_3$  (g) Parke process  
(viii) nitric oxide (h) Claude process  
(ix) silver (i) Ostwald process  
(x) chlorine (j) Solvay process
- C.** (xi) phenol (k) coloured glass  
(xii)  $Na_2S_2O_3$  (l) antichlor  
(xiii) salicylic acid (m) refractory material  
(xiv) quick lime (n) antiseptic  
(xv) CuO (o) analgesic
- D.** (xvi) Aston (p) radium  
(xvii) Priestley (q) radioactivity  
(xviii) Ramsay (r) oxygen  
(xix) Marie Curie (s) inert gas  
(xx) Bacquerel (t) mass spectrum

**VI.** Match the following choosing one item from column X and the appropriate item from column Y: (1986 -  $\frac{1}{2} \times 8 = 4$  Marks)

X	Y
(i) Lewis acid	(a) K electron capture
(ii) Philosopher's wool	(b) Zinc ore
(iii) Electrophile	(c) HCHO
(iv) Preservative	(d) $NH_4^+$
(v) Electron emission	(e) Small proton to neutron ratio
(vi) Bronsted acid	(f) $SO_3$
(vii) Black jack	(g) $BF_3$
(viii) X-ray emission	(h) ZnO

**VII.** Each entry in column X is in some way related to the entries in column Y and Z. Match the appropriate entries.

(1988 -  $1 \times 10 = 10$  Marks)

(i)	X	Y	Z
	Animal charcol	$kJ\ deg^{-1}$	watch spring
	Invar	$cm^{-1}$	$1.3805 \times 10^{-26}$
	Nichrome	Co, Ni	sugar refining
	Rydberg	Fe, Ni	cutlery
	Stainless steel	Fe, Cr, Ni, C	109677
	Boltzmann	C, $Ca_3(PO_4)_2$	heating element
(ii)	X	Y	Z
	Friedel-Crafts	Oil	Alkenes
	Fermentation	Lewis acid	Soap
	Dehydrohalogenation	Cuprous Chloride	Anhydrous $AlCl_3$
	Sandmeyer	Yeast	Chlorobenzene
	Saponification	Alcoholic alkali	Ethanol

**VIII.** Each entry in column X is in some way related to the entries in column Y and Z. Match the appropriate entries :

(1989 -  $5 \times 1 = 5$  Marks)

X	Y	Z
A. Mica	(a) Graphite crystallite	(i) Abrasive
B. Superphosphate	(b) Cubic	(ii) Insulator
C. Carbon fibres	(c) Layer structure	(iii) Fertilizer
D. Rock salt	(d) Diamond structure	(iv) Reinforced plastics
E. Carborundum	(e) Bone ash	(v) Preservative

**Example : Yeast      Fermentation      Ethanol**

**IX.** All the compounds listed in Column I react with water. Match the result of the respective reactions with the appropriate options listed in Column II. (2010)

Column-I	Column-II
(A) $(CH_3)_2SiCl_2$	(p) Hydrogen halide formation
(B) $XeF_4$	(q) Redox reaction
(C) $Cl_2$	(r) Reacts with glass
(D) $VCl_5$	(s) Polymerization
	(t) $O_2$ formation

## CHAPTER

## 23

## Analytical Chemistry

## Section-A

## JEE Advanced / IIT-JEE

## A Fill in the Blanks

- If metal ions of group III are precipitated by  $\text{NH}_4\text{Cl}$  and  $\text{NH}_4\text{OH}$  without prior oxidation by conc.  $\text{HNO}_3$  ..... is not completely precipitated. (1984 - 1 Mark)
- The formula of the deep red liquid formed on warming dichromate with KCl in concentrated sulphuric acid is ..... (1993 - 1 Mark)

## B True / False

- Addition of ammonium chloride to a solution containing ferric and magnesium ions is essential for selective precipitation of ferric hydroxide by aqueous ammonia. (1985 - 1/2 Mark)
- From the acidic solution containing copper (+2) and zinc (+2) ions, copper can be selectively precipitated using sodium sulphide. (1987 - 1 Mark)

## C MCQs with One Correct Answer

- The ion that cannot be precipitated by both HCl and  $\text{H}_2\text{S}$  is
  - $\text{Pb}^{2+}$
  - $\text{Cu}^+$
  - $\text{Ag}^+$
  - $\text{Sn}^{2+}$
 (1982 - 1 Mark)
- Which one among the following pairs of ions cannot be separated by  $\text{H}_2\text{S}$  in dilute hydrochloric acid? (1986 - 1 Mark)
  - $\text{Bi}^{3+}, \text{Sn}^{4+}$
  - $\text{Al}^{3+}, \text{Hg}^{2+}$
  - $\text{Zn}^{2+}, \text{Cu}^{2+}$
  - $\text{Ni}^{2+}, \text{Cu}^{2+}$
- An aqueous solution contains  $\text{Hg}^{2+}, \text{Hg}_2^{2+}, \text{Pb}^{2+}$  and  $\text{Cd}^{2+}$ . The addition of HCl (6N) will precipitate : (1995S)
  - $\text{Hg}_2\text{Cl}_2$  only
  - $\text{PbCl}_2$  only
  - $\text{PbCl}_2$  and  $\text{Hg}_2\text{Cl}_2$
  - $\text{PbCl}_2$  and  $\text{HgCl}_2$
- Identify the correct order of solubility of  $\text{Na}_2\text{S}$ ,  $\text{CuS}$  and  $\text{ZnS}$  in aqueous medium (2002S)
  - $\text{CuS} > \text{ZnS} > \text{Na}_2\text{S}$
  - $\text{ZnS} > \text{Na}_2\text{S} > \text{CuS}$
  - $\text{Na}_2\text{S} > \text{CuS} > \text{ZnS}$
  - $\text{Na}_2\text{S} > \text{ZnS} > \text{CuS}$
- An aqueous solution of a substance gives a white precipitate on treatment with dilute hydrochloric acid, which dissolves on heating. When hydrogen sulfide is passed through the hot acidic solution, a black precipitate is obtained. The substance is a
  - $\text{Hg}_2^{2+}$  salt
  - $\text{Cu}^{2+}$  salt
  - $\text{Ag}^+$  salt
  - $\text{Pb}^{2+}$  salt
- A gas 'X' is passed through water to form a saturated solution. The aqueous solution on treatment with silver nitrate gives a white precipitate. The saturated aqueous solution also dissolves magnesium ribbon with evolution of a colourless gas 'Y'. Identify 'X' and 'Y'. (2002S)
  - $\text{X} = \text{CO}_2, \text{Y} = \text{Cl}_2$
  - $\text{X} = \text{Cl}_2, \text{Y} = \text{CO}_2$
  - $\text{X} = \text{Cl}_2, \text{Y} = \text{H}_2$
  - $\text{X} = \text{H}_2, \text{Y} = \text{Cl}_2$
- $[\text{X}] + \text{H}_2\text{SO}_4 \longrightarrow [\text{Y}]$  a colourless gas with irritating smell,  $[\text{Y}] + \text{K}_2\text{Cr}_2\text{O}_7 + \text{H}_2\text{SO}_4 \longrightarrow$  green solution.  $[\text{X}]$  and  $[\text{Y}]$  are: (2003S)
  - $\text{SO}_3^{2-}, \text{SO}_2$
  - $\text{Cl}^-, \text{HCl}$
  - $\text{S}^{2-}, \text{H}_2\text{S}$
  - $\text{CO}_3^{2-}, \text{CO}_2$
- A solution which is  $10^{-3}$  M each in  $\text{Mn}^{2+}, \text{Fe}^{2+}, \text{Zn}^{2+}$  and  $\text{Hg}^{2+}$  is treated with  $10^{-16}$  M sulphide ion. If  $K_{\text{sp}}$  of  $\text{MnS}, \text{FeS}, \text{ZnS}$  and  $\text{HgS}$  are  $10^{-15}, 10^{-23}, 10^{-20}$  and  $10^{-54}$  respectively, which one will precipitate first? (2003S)
  - $\text{FeS}$
  - $\text{MgS}$
  - $\text{HgS}$
  - $\text{ZnS}$
- A metal nitrate reacts with KI to give a black precipitate which on addition of excess of KI is converted into orange colour solution. The cation of the metal nitrate is (2005S)
  - $\text{Hg}^{2+}$
  - $\text{Bi}^{3+}$
  - $\text{Pb}^{2+}$
  - $\text{Cu}^+$
- A solution when diluted with  $\text{H}_2\text{O}$  and boiled, gives a white precipitate. On addition of excess  $\text{NH}_4\text{Cl}/\text{NH}_4\text{OH}$ , the volume of precipitate decreases leaving behind a white gelatinous precipitate. Identify the precipitate which dissolves in  $\text{NH}_4\text{OH}/\text{NH}_4\text{Cl}$  (2006 - 3M, -1)
  - $\text{Al}(\text{OH})_3$
  - $\text{Zn}(\text{OH})_2$
  - $\text{Ca}(\text{OH})_2$
  - $\text{Mg}(\text{OH})_2$
- A solution of a metal ion when treated with KI gives a red precipitate which dissolves in excess KI to give a colourless solution. Moreover, the solution of metal ion on treatment with a solution of cobalt (II) thiocyanate gives rise to a deep blue crystalline precipitate. The metal ion is (2007)
  - $\text{Pb}^{2+}$
  - $\text{Hg}^{2+}$
  - $\text{Cu}^{2+}$
  - $\text{Co}^{2+}$
- Passing  $\text{H}_2\text{S}$  gas into a mixture of  $\text{Mn}^{2+}, \text{Ni}^{2+}, \text{Cu}^{2+}$  and  $\text{Hg}^{2+}$  ions in an acidified aqueous solution precipitates (2011)
  - $\text{CuS}$  and  $\text{HgS}$
  - $\text{MnS}$  and  $\text{CuS}$
  - $\text{MnS}$  and  $\text{NiS}$
  - $\text{NiS}$  and  $\text{HgS}$
- Upon treatment with ammoniacal  $\text{H}_2\text{S}$ , the metal ion that precipitates as a sulfide is (JEE Adv. 2013)
  - $\text{Fe}(\text{III})$
  - $\text{Al}(\text{III})$
  - $\text{Mg}(\text{II})$
  - $\text{Zn}(\text{II})$

**D MCQs with One or More Than One Correct**

- The reagents,  $\text{NH}_4\text{Cl}$  and aqueous  $\text{NH}_3$  will precipitate
  - $\text{Ca}^{2+}$
  - $\text{Al}^{3+}$  (1991 - 1 Mark)
  - $\text{Bi}^{3+}$
  - $\text{Mg}^{2+}$
  - $\text{Zn}^{2+}$
- Which of the following statement(s) is (are) correct when a mixture of  $\text{NaCl}$  and  $\text{K}_2\text{Cr}_2\text{O}_7$  is gently warmed with conc.  $\text{H}_2\text{SO}_4$ ? (1998 - 2 Marks)
  - A deep red vapour is evolved
  - The vapours when passed into  $\text{NaOH}$  solution gives a yellow solution of  $\text{Na}_2\text{CrO}_4$
  - Chlorine gas is evolved
  - Chromyl chloride is formed
- Which of the following statement(s) is (are) correct with reference to the ferrous and ferric ions? (1998 - 2 Marks)
  - $\text{Fe}^{3+}$  gives brown colour with potassium ferricyanide.
  - $\text{Fe}^{2+}$  gives blue precipitate with potassium ferricyanide.
  - $\text{Fe}^{3+}$  gives red colour with potassium thiocyanate.
  - $\text{Fe}^{2+}$  gives brown colour with ammonium thiocyanate.
- The pair(s) of ions where BOTH the ions are precipitated upon passing  $\text{H}_2\text{S}$  gas in presence of dilute  $\text{HCl}$ , is(are) (JEE Adv. 2015)
  - $\text{Ba}^{2+}, \text{Zn}^{2+}$
  - $\text{Bi}^{3+}, \text{Fe}^{3+}$
  - $\text{Cu}^{2+}, \text{Pb}^{2+}$
  - $\text{Hg}^{2+}, \text{Bi}^{3+}$
- The reagent(s) that can selectively precipitate  $\text{S}^{2-}$  from a mixture of  $\text{S}^{2-}$  and  $\text{SO}_4^{2-}$  in aqueous solution is(are) (JEE Adv. 2016)
  - $\text{CuCl}_2$
  - $\text{BaCl}_2$
  - $\text{Pb}(\text{OOCCH}_3)_2$
  - $\text{Na}_2[\text{Fe}(\text{CN})_5\text{NO}]$

**E Subjective Problems**

- Account for the following. Limit your answer to two sentences:  
The precipitation of second group sulphides in qualitative analysis is carried out with hydrogen sulphide in presence of hydrochloric acid and not nitric acid. (1979)
- Compound A is a light green crystalline solid. It gives the following tests: (1980)
  - It dissolves in dilute sulphuric acid. No gas is produced.
  - A drop of  $\text{KMnO}_4$  is added to the above solution. The pink colour disappears.
  - Compound A is heated strongly. Gases B and C, with pungent smell, come out. A brown residue D is left behind.
  - The gas mixture (B) and (C) is passed into a dichromate solution. The solution turns green.
  - The green solution from step (iv) gives a white precipitate E with a solution of barium nitrate.
  - Residue D from step (iii) is heated on charcoal in a reducing flame. It gives a magnetic substance.  
Name the compounds A, B, C, D and E
- When 16.8 g of white solid X were heated, 4.4 g of acid gas A that turned lime water milky was driven off together with 1.8 g of a gas B which condensed to a colourless liquid. The solid that remained, Y, dissolved in water to give an alkaline

solution, which with excess barium chloride solution gave a white precipitate Z. The precipitate effervesced with acid giving off carbon dioxide. Identify A, B and Y and write down the equation for the thermal decomposition of X.

(1984 - 4 Marks)

- A mixture of two salts was treated as follows : (1987 - 5 Marks)
  - The mixture was heated with manganese dioxide and concentrated sulphuric acid when yellowish green gas was liberated.
  - The mixture on heating with sodium hydroxide solution gave a gas which turned red litmus blue.
  - Its solution in water gave blue precipitate with potassium ferricyanide and red colouration with ammonium thiocyanate.
  - The mixture was boiled with potassium hydroxide and the liberated gas was bubbled through an alkaline solution of  $\text{K}_2\text{HgI}_4$  to give brown precipitate. Identify the two salts. Give ionic equations for reactions involved in the tests (i), (ii) and (iii).
- A hydrated metallic salt A, light green in colour, on careful heating gives a white anhydrous residue B. B is soluble in water and its aqueous solution reacts with  $\text{NO}$  to give a dark brown compound C. B on strong heating gives a brown residue D and a mixture of two gases E and F. The gaseous mixture when passed through acidified permanganate, discharges the pink colour and when passed through acidified  $\text{BaCl}_2$  solution gave a white precipitate. Identify A, B, C, D, E and F. (1988 - 3 Marks)
- When 20.02 g of a white solid X is heated 4.4 g of an acid gas A and 1.8 g of a neutral gas B are evolved, leaving behind a solid residue Y of weight 13.8 g. A turns lime water milky and B condenses into a liquid which changes anhydrous copper sulphate blue. The aqueous solution of Y is alkaline to litmus and gives 19.7 g of white precipitate Z with barium chloride solution. Z gives carbon dioxide with an acid. Identify A, B, X, Y and Z. (1989 - 5 Marks)
- The gas liberated on heating a mixture of two salts with  $\text{NaOH}$ , gives a reddish brown precipitate with an alkaline solution of  $\text{K}_2[\text{HgI}_4]$ . The aqueous solution of the mixture on treatment with  $\text{BaCl}_2$  gives a white precipitate which is sparingly soluble in conc.  $\text{HCl}$ . On heating the mixture with  $\text{K}_2\text{Cr}_2\text{O}_7$  and conc.  $\text{H}_2\text{SO}_4$ , red vapours of A are produced. The aqueous solution of the mixture gives a deep blue colouration B with potassium ferricyanide solution. Identify the radicals in the given mixture and write the balanced equations for the formation of A and B. (1991 - 4 Marks)
- A light bluish green crystalline compound responds to the following tests :
  - Its aqueous solution gives a brown precipitate or colour with alkaline  $\text{K}_2[\text{HgI}_4]$  solution.
  - Its aqueous solution gives a blue colour with  $\text{K}_3[\text{Fe}(\text{CN})_6]$  solution.
  - Its solution in hydrochloric acid gives a white precipitate with  $\text{BaCl}_2$  solution.  
Identify the ions present and suggest the formula of the compound. (1992 - 4 Marks)

9. An orange solid (A) on heating gave a green residue (B), a colourless gas (C) and water vapour. The dry gas (C) on passing over heated Mg gave a white solid (D). (D) on reaction with water gave a gas (E) which formed dense white fumes with HCl. Identify (A) to (E) and give reactions involved. (1993 - 3 Marks)
10. A is a binary compound of a univalent metal, 1.422 g of A reacts completely with 0.321 g of sulphur in an evacuated and sealed tube to give 1.743 g of a white crystalline solid B, that forms a hydrated double salt, C with  $\text{Al}_2(\text{SO}_4)_3$ . Identify A, B and C (1994 - 5 Marks)
11. A scarlet compound A is treated with conc.  $\text{HNO}_3$  to give a chocolate brown precipitate B. The precipitate is filtered and the filtrate is neutralised with NaOH. Addition of KI to the resulting solution gives a yellow precipitate C. The precipitate B on warming with conc.  $\text{HNO}_3$  in the presence of  $\text{Mn}(\text{NO}_3)_2$  produces a pink-coloured solution due to the formation of D. Identify A, B, C and D. Write the reaction sequence. (1995 - 4 Marks)
12. Calcium burns in nitrogen to produce a white powder which dissolves in sufficient water to produce a gas (A) and an alkaline solution. The solution on exposure to air produces a thin solid layer of (B) on the surface. Identify the compounds A and B. (1996 - 2 Marks)
13. A colourless inorganic salt (A) decomposes completely at about  $250^\circ\text{C}$  to give only two products, (B) and (C), leaving no residue. The oxide (C) is a liquid at room temperature and neutral to moist litmus paper while the gas (B) is a neutral oxide. White phosphorus burns in excess of (B) to produce a strong white dehydrating agent. Write balanced equations for the reactions involved in the above process. (1996 - 3 Marks)
14. During the qualitative analysis of a mixture containing  $\text{Cu}^{2+}$  and  $\text{Zn}^{2+}$  ions,  $\text{H}_2\text{S}$  gas is passed through an acidified solution containing these ions in order to test  $\text{Cu}^{2+}$  alone. Explain briefly. (1998 - 2 Marks)
15. A white solid is either  $\text{Na}_2\text{O}$  or  $\text{Na}_2\text{O}_2$ . A piece of red litmus paper turns white when it is dipped into a freshly made aqueous solution of the white solid. (1999 - 4 Marks)
- (i) Identify the substance and explain with balanced equation.
- (ii) Explain what would happen to the red litmus if the white solid were the other compound.
16. An aqueous solution containing one mole of  $\text{HgI}_2$  and two moles of NaI is orange in colour. On addition of excess NaI the solution becomes colourless. The orange colour reappears on subsequent addition of NaOCl. Explain with equations. (1999 - 3 Marks)
17. An aqueous blue coloured solution of a transition metal sulphate reacts with  $\text{H}_2\text{S}$  in acidic medium to give a black precipitate A, which is insoluble in warm aqueous solution of KOH. The blue solution on treatment with KI in weakly acidic medium, turns yellow and produces a white precipitate B. Identify the transition metal ion. Write the chemical reactions involved in the formation of A and B. (2000 - 4 Marks)
18. Write the chemical reactions associated with the 'borax bead test' of cobalt (II) oxide. (2000 - 3 Marks)
19. A white substance (A) reacts with dilute  $\text{H}_2\text{SO}_4$  to produce a colourless gas (B) and a colourless solution (C). The reaction between (B) and acidified  $\text{K}_2\text{Cr}_2\text{O}_7$  solution produces a green solution and a slightly coloured precipitate (D). The substance (D) burns in air to produce a gas (E) which reacts with (B) to yield (D) and a colourless liquid. Anhydrous copper sulphate is turned blue on addition of this colourless liquid. Addition of aqueous  $\text{NH}_3$  or NaOH to (C) produces first a precipitate, which dissolves in the excess of the respective reagent to produce a clear solution in each case. Identify (A), (B), (C), (D) and (E). Write the equations of the reactions involved. (2001 - 10 Marks)
20. When a white crystalline compound X is heated with  $\text{K}_2\text{Cr}_2\text{O}_7$  and concentrated  $\text{H}_2\text{SO}_4$ , a reddish brown gas A is evolved. On passing A into caustic soda solution, a yellow coloured solution of B is obtained. Neutralizing the solution B with acetic acid and on subsequent addition of lead acetate, a yellow precipitate C is obtained. When X is heated with NaOH solution, a colourless gas is evolved and on passing this gas into  $\text{K}_2\text{HgI}_4$  solution, a reddish brown precipitate D is formed. Identify A, B, C, D and X. Write the equations of reactions involved. (2002 - 5 Marks)
21. A mixture consists of A (yellow solid) and B (colourless solid) which gives lilac colour in flame.
- (a) Mixture gives black precipitate C on passing  $\text{H}_2\text{S}_{(\text{g})}$  through its aqueous solution.
- (b) C is soluble in aqua-regia and on evaporation of aqua-regia and adding  $\text{SnCl}_2$  gives greyish black precipitate D.
- The salt solution with  $\text{NH}_4\text{OH}$  gives a brown precipitate.
- (i) The sodium carbonate extract of the salt with  $\text{CCl}_4/\text{FeCl}_3$  gives a violet layer.
- (ii) The sodium carbonate extract gives yellow precipitate with  $\text{AgNO}_3$  solution which is insoluble in  $\text{NH}_3$ . Identify A and B, and the precipitates C and D. (2003 - 4 Marks)

## G

## Comprehension Based Questions

## PASSAGE-1

*p*-Amino-*N*, *N*-dimethylaniline is added to a strongly acidic solution of X. The resulting solution is treated with a few drops of aqueous solution of Y to yield blue coloration due to the formation of methylene blue. Treatment of the aqueous solution of Y with the reagent potassium hexacyanoferrate(II) leads to the formation of an intense blue precipitate. The precipitate dissolves on excess addition of the reagent. Similarly, treatment of the solution of Y with the solution of potassium hexacyanoferrate (III) leads to a brown coloration due to the formation of Z. (2009)

- The compound X is
 

(a) $\text{NaNO}_3$	(b) NaCl
(c) $\text{Na}_2\text{SO}_4$	(d) $\text{Na}_2\text{S}$
- The compound Y is
 

(a) $\text{MgCl}_2$	(b) $\text{FeCl}_2$
(c) $\text{FeCl}_3$	(d) $\text{ZnCl}_2$
- The compound Z is
 

(a) $\text{Mg}_2[\text{Fe}(\text{CN})_6]$	(b) $\text{Fe}[\text{Fe}(\text{CN})_6]$
(c) $\text{Fe}_4[\text{Fe}(\text{CN})_6]_3$	(d) $\text{K}_2\text{Zn}_3[\text{Fe}(\text{CN})_6]_2$

## PASSAGE-2

An aqueous solution of a mixture of two inorganic salts, when treated with dilute HCl, gave a precipitate (P) and a filtrate (Q). The precipitate P was found to dissolve in hot water. The filtrate (Q) remained unchanged, when treated with H<sub>2</sub>S in a dilute mineral acid medium. However, it gave a precipitate (R) with H<sub>2</sub>S in an ammoniacal medium. The precipitate R gave a coloured solution (S), when treated with H<sub>2</sub>O<sub>2</sub> in an aqueous NaOH medium.

(JEE Adv. 2013-II)

4. The precipitate P contains  
 (a) Pb<sup>2+</sup> (b) Hg<sub>2</sub><sup>2+</sup>  
 (c) Ag<sup>+</sup> (d) Hg<sup>2+</sup>
5. The coloured solution S contains  
 (a) Fe<sub>2</sub>(SO<sub>4</sub>)<sub>3</sub> (b) CuSO<sub>4</sub>  
 (c) ZnSO<sub>4</sub> (d) Na<sub>2</sub>CrO<sub>4</sub>

## PASSAGE-3

An aqueous solution of metal ion M1 reacts separately with reagents Q and R in excess to give tetrahedral and square planar complexes, respectively. An aqueous solution of another metal ion M2 always forms tetrahedral complexes with these reagents. Aqueous solution of M2 on reaction with reagent S gives white precipitate which dissolves in excess of S. The reactions are summarized in the scheme given below:

Scheme:

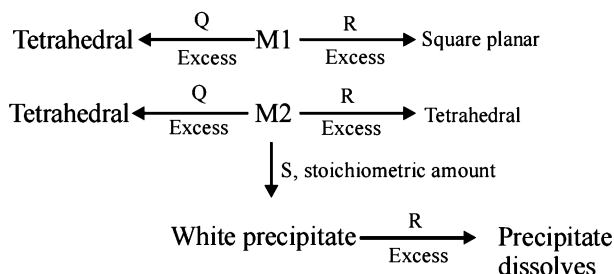

6. M1, Q and R, respectively are (JEE Adv. 2014)  
 (a) Zn<sup>2+</sup>, KCN and HCl (b) Ni<sup>2+</sup>, HCl and KCN  
 (c) Cd<sup>2+</sup>, KCN and HCl (d) Co<sup>2+</sup>, HCl and KCN

7. Reagent S is (JEE Adv. 2014)  
 (a) K<sub>4</sub>[Fe(CN)<sub>6</sub>] (b) Na<sub>2</sub>HPO<sub>4</sub>  
 (c) K<sub>2</sub>CrO<sub>4</sub> (d) KOH

## H Assertion &amp; Reason Type Questions

1. Read the following statement and explanation and answer as per the options given below : (1989 - 2 Marks)  
**Assertion** : A very dilute acidic solution of Cd<sup>2+</sup> and Ni<sup>2+</sup> gives yellow precipitate of CdS on passing hydrogen sulphide.  
**Statement** : Solubility product of CdS is more than that of NiS.  
 (a) If both assertion and statement are correct and statement is an explanation of assertion.  
 (b) If assertion is correct and statement is wrong, statement is not an explanation of assertion.  
 (c) If assertion is wrong and statement is correct, statement is not an explanation of assertion.  
 (d) If both assertion and statement are wrong and statement is not explanation of assertion.
2. Read the following statement and explanation and answer as per the options given below : (1998 - 2 Marks)  
**Assertion** : Sulphate is estimated as BaSO<sub>4</sub> and not as MgSO<sub>4</sub>.  
**Reason** : Ionic radius of Mg<sup>2+</sup> is smaller than that of Ba<sup>2+</sup>  
 (a) If both *assertion* and *reason* are correct, and *reason* is the correct explanation of the *assertion*.  
 (b) If both *assertion* and *reason* are correct, but *reason* is not the correct explanation of the *assertion*.  
 (c) If *assertion* is correct but *reason* is incorrect.  
 (d) If *assertion* is incorrect but *reason* is correct.

## I Integer Value Correct Type

1. Among PbS, CuS, HgS, MnS, Ag<sub>2</sub>S, NiS, CoS, Bi<sub>2</sub>S<sub>3</sub> and SnS<sub>2</sub>, the total number of BLACK coloured sulphides is (JEE Adv. 2014)

## Section-B JEE Main / AIEEE

1. When H<sub>2</sub>S is passed through Hg<sub>2</sub>S we get [2002]  
 (a) HgS (b) HgS + Hg<sub>2</sub>S  
 (c) Hg<sub>2</sub>S + Hg (d) None of these.
2. How do we differentiate between Fe<sup>3+</sup> and Cr<sup>3+</sup> in group III?  
 (a) by taking excess of NH<sub>4</sub>OH solution [2002]  
 (b) by increasing NH<sub>4</sub><sup>+</sup> ion concentration  
 (c) by decreasing OH<sup>-</sup> ion concentration  
 (d) both (b) and (c)
3. Which one of the following statements is correct ?  
 (a) From a mixed precipitate of AgCl and AgI, ammonia solution dissolves only AgCl [2003]  
 (b) Ferric ions give a deep green precipitate on adding potassium ferrocyanide solution  
 (c) On boiling a solution having K<sup>+</sup>, Ca<sup>2+</sup> and HCO<sub>3</sub><sup>-</sup> ions we get a precipitate of K<sub>2</sub>Ca(CO<sub>3</sub>)<sub>2</sub>  
 (d) Manganese salts give a violet borax bead test in the reducing flame
4. The compound formed in the positive test for nitrogen with the Lassaigne solution of an organic compound is [2004]  
 (a) Fe<sub>4</sub>[Fe(CN)<sub>6</sub>]<sub>3</sub> (b) Na<sub>3</sub>[Fe(CN)<sub>6</sub>]  
 (c) Fe(CN)<sub>3</sub> (d) Na<sub>4</sub>[Fe(CN)<sub>5</sub>NOS]
5. The equation which is balanced and represents the correct product(s) is: [JEE M 2014]  
 (a) Li<sub>2</sub>O + 2KCl → 2LiCl + K<sub>2</sub>O  
 (b) [CoCl(NH<sub>3</sub>)<sub>5</sub>]<sup>+</sup> + 5H<sup>+</sup> → Co<sup>2+</sup> + 5NH<sub>4</sub><sup>+</sup> + Cl<sup>-</sup>  
 (c) [Mg(H<sub>2</sub>O)<sub>6</sub>]<sup>2+</sup> + (EDTA)<sup>4-</sup>  $\xrightarrow{\text{excess NaOH}}$  [Mg(EDTA)]<sup>2+</sup> + 6H<sub>2</sub>O  
 (d) CuSO<sub>4</sub> + 4KCN → K<sub>2</sub>[Cu(CN)<sub>4</sub>] + K<sub>2</sub>SO<sub>4</sub>



# Solutions & Explanations

## 1

## Some Basic Concepts of Chemistry

### Section-A : JEE Advanced/ IIT-JEE

- A** 1. Carbon-12. 2.  $6.02 \times 10^{24}$  3. 0.4m 4. 4.14 g 5.  $+\frac{7}{3}$
- C** 1. (d) 2. (c) 3. (a) 4. (a) 5. (c) 6. (a) 7. (a)  
 8. (d) 9. (c) 10. (c) 11. (a) 12. (b) 13. (b) 14. (d)  
 15. (c) 16. (b) 17. (a) 18. (d) 19. (a) 20. (d) 21. (c)  
 22. (a) 23. (b) 24. (d) 25. (a) 26. (a) 27. (b) 28. (d)
- E** 1. 4.87 g 2. Al 54.87%, Mg 45.13% 3. 59.33% 4. 8.38  
 5. (a)  $9.5 \times 10^{-3}$  gram mole, (b) 0.437 moles 6.  $\text{CH}_4$  7.  $\text{Na}_2\text{O} = 3.58\%$ ,  $\text{K}_2\text{O} = 10.62\%$   
 8. 24 9. 1.338 gm  
 10. (a) 1.95 parts; (b) 1 milli equivalents; (c) (i) Mg, (ii) 0.25g, (iii) 62.5 ml 11.  $\text{C}_7\text{H}_8$   
 12.  $3.5 \times 10^{-3}$  g 13. 53.53 14. 0.588N 16.  $39.6 \text{ g l}^{-1}$   
 17. (i) 37.92; (ii) 0.065; (iii) 7.74 m, 3.87 m 18. Ca 20. 2  
 21. 6.3648 g 22.  $\text{HI} < \text{I}_2 < \text{ICl} < \text{HIO}_4$  23. (i) 1.446 g, 0.112 M; (ii) 1.7532 g, 0.1344 M  
 24. (i) 0.56; (ii) 0.0999 25. 6.5 g 26. +2, +4, +6, 16.66 ml  
 27. 1.12 g, 0.90 g 28. 3.324 g, 1.676 g 29. 10.43 m 30. 1 : 2  
 31. 6 32.  $\text{Na}_2\text{CO}_3$ -26.5%,  $\text{Na}_2\text{SO}_4$ -31.5% 33. 85%  
 34. 0.0075 M,  $\text{Pb}^{2+} = 0.05357 \text{ M}$ ,  $\text{NO}_3^- = 0.3214 \text{ M}$ ,  $\text{Cr}^{3+} = 0.0714 \text{ M}$  35. 15.05%  
 36. 0.25 M, 0.24 m,  $4.3 \times 10^{-3}$  37. 49.33%, 34.8% 38. 0.062  
 39. 8.097 ml 40.  $7.09 \times 10^7$  41. 0.1 42. 55.55 M
- H** 1. (b)
- I** 1. 3 2. 7 3. 5 4. 4

### Section-B : JEE Main/ AIEEE

1. (c) 2. (c) 3. (a) 4. (a) 5. (d) 6. (b) 7. (a) 8. (a)  
 9. (b) 10. (d) 11. (d) 12. (a) 13. (d) 14. (a) 15. (c) 16. (d)  
 17. (b)

### Section-A

### JEE Advanced/ IIT-JEE

#### A. Fill in the Blanks

1. Carbon (C-12)

2.  $6.02 \times 10^{24}$

18 ml  $\text{H}_2\text{O} = 18 \text{ g H}_2\text{O}$  ( $\because$  density of water = 1 g/cc)  
 $= 1 \text{ mole of H}_2\text{O}$ .

1 Mole of  $\text{H}_2\text{O} = 10 \times 6.02 \times 10^{23}$  electrons

( $\because$  Number of electrons present in one molecule of water

$= 2 + 8 = 10$ )

$= 6.02 \times 10^{24}$  electrons

3. TIPS/Formulae : Molality =  $\frac{\text{Moles of solute}}{\text{Mass of solvent in kg}}$

$= \frac{\text{wt. of solute in gram} / \text{M. wt. of solute}}{\text{Mass of solvent in kg}}$

$$\text{Molality} = \frac{3/30}{250/1000} = 0.4\text{m}$$

4. **TIPS/Formulæ :**

1 Mole =  $6.023 \times 10^{23}$  molecules = Molecular weight in gms.  
 Weight of  $6.023 \times 10^{23}$  (Avogadro's number) molecules of  $\text{CuSO}_4 \cdot 5\text{H}_2\text{O}$  = Molecular wt. of  $\text{CuSO}_4 \cdot 5\text{H}_2\text{O}$  = 249 g.  
 $\therefore$  Weight of  $1 \times 10^{22}$  molecules of  $\text{CuSO}_4 \cdot 5\text{H}_2\text{O}$

$$= \frac{249 \times 1 \times 10^{22}}{6.023 \times 10^{23}} = 4.14\text{ g}$$

5. **NOTE :** Sum of oxidation states of all atoms (elements) in a neutral compound is zero.

**TIPS/Formulæ :** As  $\text{YBa}_2\text{Cu}_3\text{O}_7$  is neutral.

$$(+3) + 2(+2) + 3(x) + 7(-2) = 0$$

$$\text{or } 3 + 4 + 3x - 14 = 0$$

$$\Rightarrow 3x + 7 - 14 = 0 \quad \text{or} \quad x = +\frac{7}{3}$$

**C. MCQs with ONE Correct Answer**

1. (d)  $4\text{Al} + 3\text{O}_2 \longrightarrow 2\text{Al}_2\text{O}_3$   
 At. wt. of Al = 27  
 Thus  $4 \times 27$  g of Al reacts with oxygen =  $3 \times 32$  g  
 $\therefore$  27 g of Al reacts with oxygen =  $\frac{3 \times 32}{4 \times 27} \times 27$  g  
 = 24 g
2. (c) No. of nitrogen atoms =  $\frac{\text{Mass in grams}}{\text{Atomic wt.}} = \frac{28}{14} = 2$   
 No. of oxygen atoms =  $\frac{\text{Mass in grams}}{\text{Atomic wt.}} = \frac{80}{16} = 5$   
 $\therefore$  Formula of compound is  $\text{N}_2\text{O}_5$ .
3. (a) (a) 18 g of  $\text{H}_2\text{O}$  =  $6.02 \times 10^{23}$  molecules of  $\text{H}_2\text{O}$   
 $\therefore$  36 g of  $\text{H}_2\text{O}$  =  $2 \times 6.02 \times 10^{23}$  molecules of  $\text{H}_2\text{O}$   
 =  $12.04 \times 10^{23}$  molecules of  $\text{H}_2\text{O}$   
 (b) 28 g of CO =  $6.02 \times 10^{23}$  molecules of CO  
 (c) 46 g of  $\text{C}_2\text{H}_5\text{OH}$  =  $6.02 \times 10^{23}$  molecules of  $\text{C}_2\text{H}_5\text{OH}$   
 (d) 108 g of  $\text{N}_2\text{O}_5$  =  $6.02 \times 10^{23}$  molecules of  $\text{N}_2\text{O}_5$   
 $\therefore$  54 g of  $\text{N}_2\text{O}_5$  =  $\frac{1}{2} \times 6.02 \times 10^{23}$  molecules of  $\text{N}_2\text{O}_5$   
 =  $3.01 \times 10^{23}$  molecules of  $\text{N}_2\text{O}_5$   
 $\therefore$  36 g of water has highest number of molecules.
4. (a) No. of  $e^-$  in C = 6 and in O = 8  
 $\therefore$  Total no. of  $e^-$  in  $\text{CO}_2$  =  $6 + 8 \times 2 = 22$
5. (c) Let mass of oxygen = 1g, Then mass of nitrogen = 4g  
 Mol. wt. of  $\text{N}_2$  = 28g, Mol. wt. of  $\text{O}_2$  = 32g  
 28 g of  $\text{N}_2$  has =  $6.02 \times 10^{23}$  molecules of nitrogen  
 4 g of  $\text{N}_2$  has =  $\frac{6.02 \times 10^{23}}{28} \times 4$  molecules of nitrogen  
 =  $\frac{6.02 \times 10^{23}}{7}$  molecules of nitrogen

32 g of  $\text{O}_2$  has =  $6.02 \times 10^{23}$  molecules of oxygen

$$\therefore 1\text{g of } \text{O}_2 \text{ has} = \frac{6.02 \times 10^{23}}{32} \times 1 = \frac{6.02 \times 10^{23}}{32} \text{ molecules of oxygen}$$

Thus, ratio of molecules of oxygen : nitrogen

$$= \frac{6.02 \times 10^{23} / 32}{6.02 \times 10^{23} / 7} = 7 : 32$$

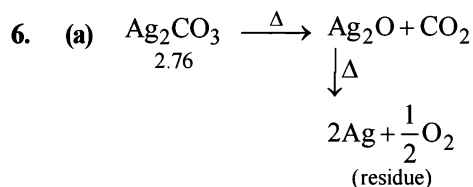

**NOTE :**  $\text{Ag}_2\text{O}$  is thermally unstable and decompose on heating liberating oxygen]

Mol. wt. of  $\text{Ag}_2\text{CO}_3$  =  $108 \times 2 + 12 + 16 \times 3 = 276$  g

$\therefore$  276 g of  $\text{Ag}_2\text{CO}_3$  on heating gives residue =  $2 \times 108 = 216$  g of Ag

$$\therefore 2.76 \text{ g of } \text{Ag}_2\text{CO}_3 \text{ on heating gives} = \frac{216}{276} \times 2.76 = 2.16 \text{ g of Ag}$$

7. (a) The change involved is  $\text{MnO}_4^- + e^- \longrightarrow \text{MnO}_4^{2-}$   
 i.e. it involves only one electron

$$\text{Eq. wt} = \frac{\text{Mol. wt}}{\text{No. of } e^- \text{ involved}} = \frac{M}{1} = M \quad [\because \text{Mol. wt.} = M]$$

8. (d) **TIPS/Formulæ :**  
 (i) Write balanced chemical equation for chemical change.  
 (ii) Find limiting reagent.  
 (iii) Amount of product formed will be determined by amount of limiting reagent.

The balanced equation is :

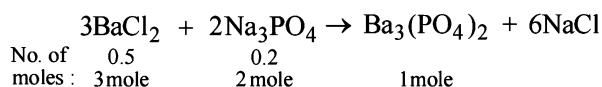

Limiting reagent is  $\text{Na}_3\text{PO}_4$  (0.2 mol),  $\text{BaCl}_2$  is in excess.

From the above equation :

2.0 moles of  $\text{Na}_3\text{PO}_4$  yields  $\text{Ba}_3(\text{PO}_4)_2 = 1$  mole

$$\therefore 0.2 \text{ moles of } \text{Na}_3\text{PO}_4 \text{ will yield } \text{Ba}_3(\text{PO}_4)_2 = \frac{1}{2} \times 0.2 = 0.1 \text{ mol.}$$

9. (c) **TIPS/Formulæ :**  
 (i) Find oxidation state of N in  $\text{N}_2\text{H}_4$ .  
 (ii) Find change in oxidation number with the help of number of electrons given out during formation of compound Y.  
 $\text{N}_2\text{H}_4 \rightarrow Y + 10 e^-$ , Calculation of O.S. of N in  $\text{N}_2\text{H}_4$  :  
 $2x + 4 = 0 \Rightarrow x = -2$   
 The two nitrogen atoms will balance the charge of 10 e.  
 Hence oxidation state of N will increase by +5, i.e. from -2 to +3.

10. (c) **NOTE:**

The sum of oxidation states of all atoms in compound is zero. Calculation of O.S. of C in  $\text{CH}_2\text{O}$ .

$$x + 2 + (-2) = 0 \Rightarrow x = 0$$

11. (a) **TIPS/Formulae:**

$$\text{Molality} = \frac{\text{Number of moles of solute}}{\text{Mass of solvent in kg}}$$

A molal solution is one which contains one mole of

solute per 1000 g of solvent.  $\left\{ \therefore 1\text{m} = \frac{1\text{mole}}{1\text{kg}} \right\}$

12. (b) **TIPS/Formulae:**

Sum of oxidation state of all atoms in neutral compound is zero. Let the oxidation state of iron in the complex ion

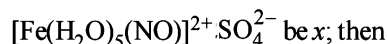

$$x + 5 \times 0 + 0 = +2. \therefore x = +2$$

13. (b) For equivalent weight of  $\text{MnSO}_4$  to be half of its molecular weight, change in oxidation state must be equal to 2. It is possible only when oxidation state of Mn in product is + 4. Since oxidation state of Mn in  $\text{MnSO}_4$  is + 2. So,  $\text{MnO}_2$  is correct answer.

In  $\text{MnO}_2$ , O.S. of Mn = +4

$$\therefore \text{Change in O.S. of Mn} = +4 - (+2) = +2$$

14. (d) **TIPS/Formulae:**

(i) Volume of substance changes with temperature and mass is not effected by change in temperature.

(ii) Find expression which does not have volume term in it.

(a) Molarity – Moles of solute/volume of solution in L

(b) Normality – gm equivalents of solute/volume of solution in L.

(c) Formality – gm formula wt./volume of solution in L.

(d) Molality – Moles of solute/mass of solvent in kg

$\therefore$  Molality does not involve volume term.

$\therefore$  It is independent of temperature.

15. (c)  $2 + 2(2 + x - 4) = 0$  [ $\therefore \text{Ba}(\text{H}_2\text{PO}_2)_2$  is neutral molecule] or  $2x - 2 = 0 \Rightarrow x = +1$ 16. (b) **TIPS/Formulae:**

(i) Write balance chemical equation for given change.

(ii) Identify most electronegative element and find its oxidation state.

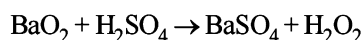

Oxygen is the most electronegative element in the reaction and has the oxidation states of  $-1$  (in  $\text{H}_2\text{O}_2$ ) and  $-2$  (in  $\text{BaSO}_4$ ). In  $\text{H}_2\text{O}_2$ , peroxo ion is present.

17. (a) **TIPS/Formulae:**

Balance the reaction by ion electron method.

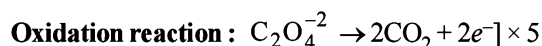

**Reduction reaction:**

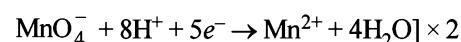

**Net reaction:**

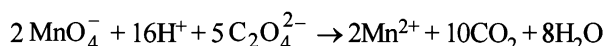
18. (d) **TIPS/Formulae:**

(i)  $\text{H}_3\text{PO}_3$  is dibasic acid as it contains two  $-\text{OH}$  groups.

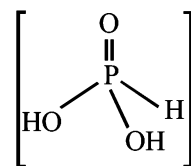

(ii) Normality = Molarity  $\times$  basicity of acid.

(iii) Basicity of  $\text{H}_3\text{PO}_3 = 2$

$$\therefore \text{Normality} = 0.3 \times 2 = 0.6$$

19. (a) **TIPS/Formulae:**

(i) Oxidation state of element in its free state is zero.

(ii) Sum of oxidation states of all atoms in compound is zero.

O.N. of S in  $\text{S}_8 = 0$ ; O.N. of S in  $\text{S}_2\text{F}_2 = +1$ ;

O.N. of S in  $\text{H}_2\text{S} = -2$ ;

20. (d) **TIPS/Formulae:**

(i) In an ion sum of oxidation states of all atoms is equal to charge on ion and in a compound sum of oxidation states of all atoms is always zero.

Oxidation state of Mn in  $\text{MnO}_4^- = +7$

Oxidation state of Cr in  $\text{Cr}(\text{CN})_6^{3-} = +3$

Oxidation state of Ni in  $\text{NiF}_6^{2-} = +4$

Oxidation state of Cr in  $\text{CrO}_2\text{Cl}_2 = +6$

21. (c) **TIPS/Formulae:**

(i) In a disproportionation reaction same element undergoes oxidation as well as reduction during the reaction.

(ii) In decomposition reaction a molecule breaks down to more than one atoms or molecules

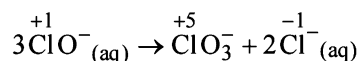

It is disproportionation reaction because Cl is both oxidised ( $+1$  to  $+5$ ) and reduced ( $+1$  to  $-1$ ) during reaction.

22. (a) **TIPS/Formulae:**

Equivalents of  $\text{H}_2\text{C}_2\text{O}_4 \cdot 2\text{H}_2\text{O} = \text{Equivalents of NaOH}$   
(At equivalence point)

$$\text{Strength of } \text{H}_2\text{C}_2\text{O}_4 \cdot 2\text{H}_2\text{O} \text{ (in g/L)} = \frac{6.3}{250/1000} = 25.2 \text{ g/L}$$

$$\text{Normality of } \text{H}_2\text{C}_2\text{O}_4 \cdot 2\text{H}_2\text{O} = \frac{\text{Strength}}{\text{Eq. wt}} = \frac{25.2}{63} = 0.4\text{N}$$

$$\left\{ \text{Eq. wt. of oxalic acid} = \frac{\text{Mol. wt}}{2} = \frac{126}{2} = 63 \right\}$$

Using normality equation:

$$N_1V_1 = N_2V_2$$

$$(\text{H}_2\text{C}_2\text{O}_4 \cdot 2\text{H}_2\text{O}) \quad (\text{NaOH})$$

$$0.4 \times 10 = 0.1 \times V_2 \text{ or } V_2 = \frac{0.4 \times 10}{0.1} = 40 \text{ ml.}$$

**23. (b) TIPS/Formulae :**

(i) Find change in oxidation number of Cr atom.

(ii) 
$$\text{Eq. wt.} = \frac{\text{Molecular wt.}}{\text{change in O.N.}}$$

In iodometry,  $\text{K}_2\text{Cr}_2\text{O}_7$  liberates  $\text{I}_2$  from iodides (NaI or KI). Thus it is titrated with  $\text{Na}_2\text{S}_2\text{O}_3$  solution.

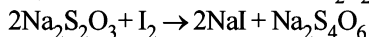

O.N. of Cr changes from +6 (in  $\text{K}_2\text{Cr}_2\text{O}_7$ ) to +3. i.e. +3 change for each Cr atom

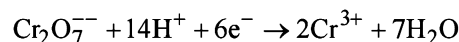

Thus, one mole of  $\text{K}_2\text{Cr}_2\text{O}_7$  accepts 6 mole of electrons.

$$\therefore \text{Equivalent weight} = \frac{\text{Molecular weight}}{6}$$

**24. (d) TIPS/Formulae :**(i) Mass of one electron =  $9.108 \times 10^{-31}$  kg(ii) 1 mole of electron =  $6.023 \times 10^{23}$  electrons

Weight of 1 mole of electron

= Mass of one electron  $\times$  Avogadro Number

$$= 9.108 \times 10^{-31} \times 6.023 \times 10^{23} \text{ kg}$$

$\therefore$  No. of moles of electrons in 1 kg

$$= \frac{1}{9.108 \times 10^{-31} \times 6.023 \times 10^{23}} = \frac{1}{9.108 \times 6.023} \times 10^8$$

**25. (a) TIPS/Formulae :**

Atomic weight in gms =  $6.023 \times 10^{23}$  atoms = 1 Mole atoms

(i) Number of atoms in 24 g of C

$$= \frac{24}{12} \times 6.023 \times 10^{23} = 2 \times 6.023 \times 10^{23} \text{ atom}$$

$$= 2 \text{ mole atoms}$$

(ii) Number of atoms in 56 g of Fe

$$= \frac{56}{56} \times 6.023 \times 10^{23} = 6.023 \times 10^{23} \text{ atom}$$

$$= 1 \text{ mole atoms}$$

(iii) Number of atoms in 27 g of Al

$$= \frac{27}{27} \times 6.023 \times 10^{23} = 6.023 \times 10^{23} \text{ atom}$$

$$= 1 \text{ mole atoms}$$

(iv) Number of atoms in 108 g of Ag

$$= \frac{108}{108} \times 6.023 \times 10^{23} = 6.023 \times 10^{23} \text{ atom}$$

$$= 1 \text{ mole atoms}$$

$\therefore$  24 g of C has maximum number of atoms.

**26. (a) TIPS/Formulae :**

Write the reaction for chemical change during reaction and equate moles of products formed.

$[\text{Co}(\text{NH}_3)_5\text{SO}_4]\text{Br}$  has ionisable  $\text{Br}^-$  ions &  $[\text{Co}(\text{NH}_3)_5\text{Br}]\text{SO}_4$  has ionisable  $\text{SO}_4^{2-}$  ion.

Given mixture  $X = 0.02$  mol of  $[\text{Co}(\text{NH}_3)_5\text{SO}_4]\text{Br}$  and 0.02 mol of  $[\text{Co}(\text{NH}_3)_5\text{Br}]\text{SO}_4$

Volume = 2 L

$\therefore$  Mixture  $X$  has 0.02 mol. of  $[\text{Co}(\text{NH}_3)_5\text{SO}_4]\text{Br}$  and 0.02 mol of  $[\text{Co}(\text{NH}_3)_5\text{Br}]\text{SO}_4$  in 2 L of solution

$\therefore$  Conc. of  $[\text{Co}(\text{NH}_3)_5\text{SO}_4]\text{Br}$  and  $[\text{Co}(\text{NH}_3)_5\text{Br}]\text{SO}_4 = 0.01$  mol/L for each of them.

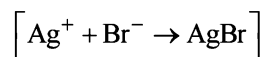
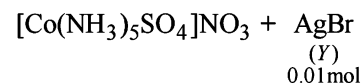
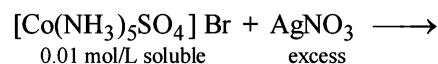
(i) 1 L mixture of  $X$  + excess  $\text{AgNO}_3 \rightarrow Y$ 

$\therefore$  No. of moles of  $Y = 0.01$

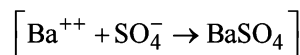
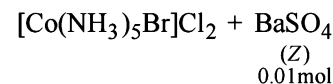
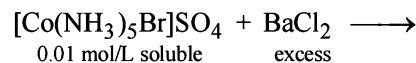
(ii) Also 1 L mixture of  $X$  + excess  $\text{BaCl}_2 \rightarrow Z$ 

$\therefore$  moles of  $Z = 0.01$ .

**27. (b) TIPS/Formulae :**

The highest O.S. of an element is equal to the number of its valence electrons

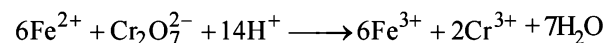
(i)  $[\text{Fe}(\text{CN})_6]^{3-}$ , O.N. of Fe = +3, $[\text{Co}(\text{CN})_6]^{3-}$ , O.N. of Co = +3(ii)  $\text{CrO}_2\text{Cl}_2$ , O.N. of Cr = +6, (Highest O.S. of Cr) $[\text{MnO}_4]^-$  O.N. of Mn = +7 (Highest O.S. of Mn)(iii)  $\text{TiO}_3$ , O.N. of Ti = +6,  $\text{MnO}_2$  O.N. of Mn = +4(iv)  $[\text{Co}(\text{CN})_6]^{3-}$ , O.N. of Co = +3, $\text{MnO}_3$ , O.N. of Mn = +6**28. (d) The following reaction occurs:**

From the above equation, we find that Mohr's salt ( $\text{FeSO}_4 \cdot (\text{NH}_4)_2\text{SO}_4 \cdot 6\text{H}_2\text{O}$ ) and dichromate reacts in 6 : 1 molar ratio.

**E. Subjective Problems****1. TIPS/Formulae :**

Write the balance chemical equation and use mole concept for limiting reagent.

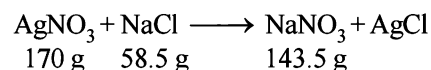

From the given data, we find  $\text{AgNO}_3$  is limiting reagent as NaCl is in excess.

$$\begin{aligned} \therefore 170.0 \text{ g of AgNO}_3 \text{ precipitates AgCl} &= 143.5 \text{ g} \\ \therefore 5.77 \text{ g of AgNO}_3 \text{ precipitates AgCl} & \\ &= \frac{143.5}{170.0} \times 5.77 = \mathbf{4.87 \text{ g}} \end{aligned}$$

**2. TIPS/Formulae :**

- (i) Find volume of  $\text{H}_2$  at N.T.P.  
 (ii) Total amount of  $\text{H}_2$  liberated =  $\text{H}_2$  liberated by Mg & HCl +  $\text{H}_2$  liberated by Al & HCl.

Conversion of volume of  $\text{H}_2$  to N.T.P

Given conditions	N.T.P conditions
$P_1 = 0.92 \text{ atm.}$	$P_2 = 1 \text{ atm.}$
$V_1 = 1.20 \text{ litres}$	$V_2 = ?$
$T_1 = 0 + 273 = 273 \text{ K}$	$T_2 = 273 \text{ K}$

Applying ideal gas equation,  $\frac{P_1 V_1}{T_1} = \frac{P_2 V_2}{T_2}$

$$\frac{0.92 \times 1.20}{273} = \frac{1 \times V_2}{273}, V_2 = \frac{0.92 \times 1.20 \times 273}{273 \times 1} \text{ litres}$$

$$= 1.104 \text{ litres} = 1104 \text{ ml}$$

The relevant chemical equations are

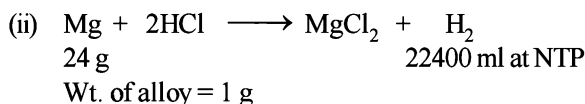
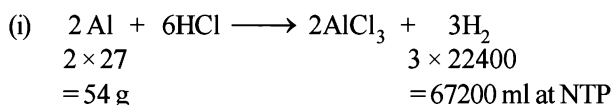

Let the wt. of aluminium in alloy =  $x$  g

$$\therefore \text{Wt. of magnesium in alloy} = (1 - x) \text{ g}$$

According to equation (i)

$$54 \text{ g of Al} = 67200 \text{ ml of H}_2 \text{ at N.T.P}$$

$$\therefore x \text{ g of Al} = \frac{67200}{54} \times x = 1244.4 x \text{ ml of H}_2 \text{ at N.T.P}$$

Similarly, from equation (ii)

$$24 \text{ g of Mg} = 22400 \text{ ml of H}_2 \text{ at N.T.P}$$

$$(1 - x) \text{ g of Mg} = \frac{22400}{24} \times (1 - x) = 933.3 (1 - x) \text{ ml of H}_2$$

Hence total vol. of  $\text{H}_2$  collected at N.T.P

$$= 1244.4 x + 933.3 (1 - x) \text{ ml}$$

But total vol. of  $\text{H}_2$  as calculated above = 1104 ml

$$\therefore 1244.4 x + 933.3 (1 - x) = 1104 \text{ ml}$$

$$1244.4 x - 933.3 x = 1104 - 933.3$$

$$311.1 x = 170.7, x = 0.5487$$

Hence 1 g of alloy contains Al = 0.5487 g

$$\therefore \text{Percentage of Al in alloy} = \frac{0.5487 \times 100}{1} = \mathbf{54.87\%}$$

$$\% \text{ of Mg in alloy} = 100 - 54.87 = \mathbf{45.13\%}$$

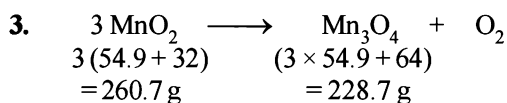

Let the amount of pyrolusite ignited = 100.00 g

$$\therefore \text{Wt. of MnO}_2 = 80 \text{ g} \quad (80\% \text{ of } 100 \text{ g} = 80 \text{ g})$$

$$\text{Wt. of SiO}_2 \text{ and other inert substances} = 15 \text{ g}$$

$$\text{Wt. of water} = 100 - (80 + 15) = 5 \text{ g}$$

According to equation,

$$260.7 \text{ g of MnO}_2 \text{ gives} = 228.7 \text{ g of Mn}_3\text{O}_4$$

$$\therefore 80 \text{ g of MnO}_2 \text{ gives} = \frac{228.7}{260.7} \times 80 = 70.2 \text{ g of Mn}_3\text{O}_4$$

**NOTE :**

During ignition,  $\text{H}_2\text{O}$  present in pyrolusite is removed while silica and other inert substances remain as such.

$$\therefore \text{Total wt. of the residue} = 70.2 + 15 = 85.2 \text{ g}$$

Calculation of % of Mn in ignited  $\text{Mn}_3\text{O}_4$

$$\begin{array}{ccc} 3 \text{ Mn} & = & \text{Mn}_3\text{O}_4 \\ 3 \times 54.9 & = & 3 \times 54.9 + 64 = 228.7 \text{ g} \end{array}$$

Since, 228.7 g of  $\text{Mn}_3\text{O}_4$  contains 164.7 g of Mn

$$70.2 \text{ g of Mn}_3\text{O}_4 \text{ contains} = \frac{164.7}{228.7} \times 70.2 = 50.55 \text{ g of Mn}$$

$$\text{Weight of residue} = 85.2 \text{ g}$$

Hence, percentage of Mn in the ignited sample

$$= \frac{50.55}{85.2} \times 100 = \mathbf{59.33\%}$$

**4. TIPS/Formulae :**

- (i) Find the volume of  $\text{CO}_2$  at NTP  
 (ii) Find molecular wt. of metal carbonate  
 (iii) Find the wt. of metal  
 (iv) Calculate equivalent weight of metal  
 Given  $P_1 = 700 \text{ mm}$ ,  $P_2 = 760 \text{ mm}$ ,  $V_1 = 1336 \text{ ml}$ ,  $V_2 = ?$   
 $T_1 = 300 \text{ K}$ ,  $T_2 = 273 \text{ K}$

$$\frac{P_1 V_1}{T_1} = \frac{P_2 V_2}{T_2}, \text{ or } V_2 = \frac{P_1 V_1 T_2}{P_2 T_1} = \frac{700 \times 1336 \times 273}{760 \times 300}$$

$$= 1119.78 \text{ ml} = 1.12 \text{ L at NTP}$$

$$\therefore 1.12 \text{ L of CO}_2 \text{ is given by carbonate} = 4.215 \text{ g}$$

$$\text{Molecular weight of metal carbonate} = \frac{4.215}{1.12} \times 22.4$$

$$= 84.3$$

Metal carbonate is  $\text{MCO}_3 = \text{M} + 12 + 48 = \text{M} + 60$

$$\text{Atomic weight of M} = 84.3 - 60 = 24.3$$

$$\text{Eq. wt. of metal} = \frac{1}{2} \times \text{M. wt.} = \frac{1}{2} \times 24.3 = 12.15$$

5. (a) Equivalents of  $\text{KMnO}_4 = \text{Equivalents of FeSO}_4 \cdot 7\text{H}_2\text{O}$

$$5.4 \text{ ml } 0.1 \text{ N KMnO}_4 = \frac{5.4 \times 0.1}{1000} = 5.4 \times 10^{-4} \text{ equivalents}$$

$$\text{Amount of FeSO}_4 = 5.4 \times 10^{-4} \times \text{Mol wt. of FeSO}_4 \cdot 7\text{H}_2\text{O}$$

$$= 5.4 \times 10^{-4} \times 278 = 0.150 \text{ g}$$

Total weight of mixture = 5.5 g

$$\text{Amount of ferric sulphate} = 5.5 - 0.150 \text{ g} = 5.35 \text{ g}$$

$$\text{Hence Moles of ferric sulphate} = \frac{\text{Mass}}{\text{M. wt.}} = \frac{5.35}{562}$$

$$= \mathbf{9.5 \times 10^{-3} \text{ gram-mole}}$$

- (b) Using the relation, Mol. wt. = 2 × vapour density, we get

$$\text{Mol. wt.} = 2 \times 38.3 = 76.6$$

$$\text{No. of moles} = \frac{\text{Mass}}{\text{Mol. wt.}} = \frac{100}{76.6} = 1.30 \quad \dots(i)$$

Let weight of  $\text{NO}_2$  in mixture =  $x$  g  
Then weight of  $\text{N}_2\text{O}_4$  in mixture =  $100 - x$

$$\text{No. of moles of } \text{NO}_2 = \frac{\text{Mass}}{\text{Mol. wt.}} = \frac{x}{46} \quad \dots(ii)$$

$$\text{No. of moles of } \text{N}_2\text{O}_4 = \frac{\text{Mass}}{\text{Mol. wt.}} = \frac{100 - x}{92} \quad \dots(iii)$$

According to problem

$$1.30 = \frac{x}{46} + \frac{100 - x}{92}$$

On solving the equation we find,  $x = 20.1$

$\therefore$  weight of  $\text{NO}_2 = 20.1$  g

$$\text{Moles of } \text{NO}_2 = \frac{\text{Mass}}{\text{M. wt.}} = \frac{20.1}{46} = \mathbf{0.437 \text{ moles.}}$$

6. Volume of oxygen taken = 30 ml,  
Volume of unused oxygen = 15 ml  
Volume of  $\text{O}_2$  used = Volume of  $\text{O}_2$  added - Volume of  $\text{O}_2$  left  
=  $30 - 15 = 15$  ml

Volume of  $\text{CO}_2$  produced  
= Volume of gaseous mixture after explosion -  
Volume of unused oxygen

or Volume of  $\text{CO}_2$  produced =  $25 - 15 = 10$  ml

Volume of hydrocarbon = 5 ml

General equation for combustion of a hydrocarbon is as follows -

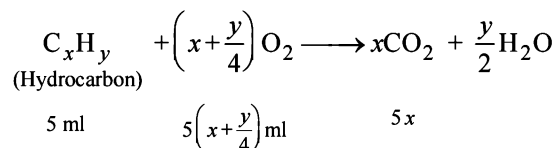

$\therefore$  Volume of  $\text{CO}_2$  produced =  $5x$ , Since Volume of  $\text{CO}_2 = 10$  ml  
 $\therefore 5x = 10 \Rightarrow x = 2$ , Volume of  $\text{O}_2$  used = 15 ml

$$\therefore 5\left(x + \frac{y}{4}\right) = 15 \Rightarrow x + \frac{y}{4} = 3$$

$$\Rightarrow 2 + \frac{y}{4} = 3 \quad (\because x = 2) \quad \Rightarrow 8 + y = 12 \therefore y = 4$$

Hence Molecular formula of hydrocarbon is  $\text{C}_2\text{H}_4$ .

7. **TIPS/Formulae :**

(i) Equate given mass of  $\text{AgCl}$  against mass obtained from  $\text{NaCl}$  and  $\text{KCl}$

(ii)  $2\text{NaCl} \equiv \text{Na}_2\text{O}$  &  $2\text{KCl} \equiv \text{K}_2\text{O}$

Let amount of  $\text{NaCl}$  in mixture =  $x$  gm

$\therefore$  amount of  $\text{KCl}$  in mixture =  $(0.118 - x)$  gm

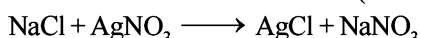

58.5 g                      143.5 g

$\therefore 58.5$  g  $\text{NaCl}$  gives  $\text{AgCl} = 143.5$ g

$$\therefore x \text{ g } \text{NaCl} \text{ gives } \text{AgCl} = \frac{143.5}{58.5} \times x \text{ g}$$

Again

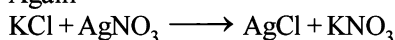

74.5 g                      143.5 g

$\therefore 74.5$  g  $\text{KCl}$  gives  $\text{AgCl} = 143.5$ g

$\therefore (0.118 - x)$  g  $\text{KCl}$  gives  $\text{AgCl} = \left(\frac{143.5}{74.5} \times 0.118 - x\right)$  g

Total weight of  $\text{AgCl} = 0.2451$ g

$$\therefore \left(\frac{143.5}{58.5} \times x\right) + \left[\frac{143.5}{74.5} \times (0.118 - x)\right] = 0.2451$$

$\therefore x = 0.0338$ g

$\therefore$  Amount of  $\text{NaCl}$  in mixture =  $0.0338$ g

$\therefore$  Amount of  $\text{KCl}$  in mixture =  $0.118 - 0.0338 = 0.0842$ g

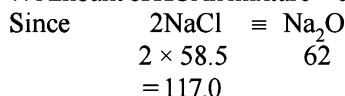

$\therefore 117$ g  $\text{NaCl}$  is equivalent to =  $62.0$ g  $\text{Na}_2\text{O}$

$\therefore 0.0338$ g  $\text{NaCl}$  is equivalent to =  $\frac{62.0}{117} \times 0.0338$  g  $\text{Na}_2\text{O}$   
=  $0.0179$ g

% of  $\text{Na}_2\text{O}$  in 0.5g of feldspar =  $\frac{0.0179}{0.500} \times 100 = 3.58\%$

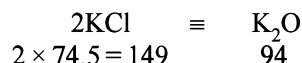

$\therefore 149$ g of  $\text{KCl}$  is equivalent to =  $94$ g  $\text{K}_2\text{O}$

$\therefore 0.0842$ g of  $\text{KCl}$  is equivalent to =  $\frac{94}{149} \times 0.0842$   
=  $0.0531$ g  $\text{K}_2\text{O}$

$\therefore$  % of  $\text{K}_2\text{O}$  in 0.5g of feldspar =  $\frac{0.0531}{0.5} \times 100 = 10.62\%$

**% of  $\text{Na}_2\text{O}$  in feldspar = 3.58%**

**% of  $\text{K}_2\text{O}$  in feldspar = 10.62%**

8. According to problem, three atoms of  $\text{M}$  combine with 2 atoms of  $\text{N}$

$\therefore$  Formula of compound is  $\text{M}_3\text{N}_2$  (Where  $\text{M}$  is the metal)

Equivalent wt of  $\text{N} = \frac{14}{3}$  ( $\because$  valency of  $\text{N}$  in compound is 3)

$\therefore 28$  g  $\text{N}$  combines with =  $72$ g metal

$\therefore 14/3$   $\text{N}$  combines with =  $\frac{72}{28} \times \frac{14}{3} = 12$

$\therefore$  Eq. wt. of metal = 12

At wt of metal = Eq. wt  $\times$  valency =  $12 \times 2 = 24$

[Valency of metal = 2]

9. Following reactions take place-

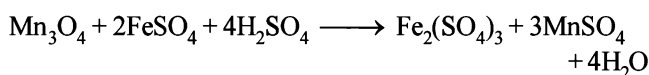
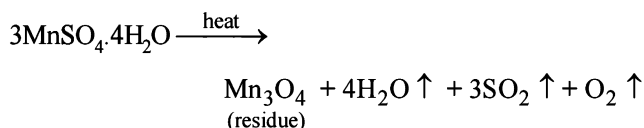

Milliequivalents of  $\text{FeSO}_4$  in 30 ml of 0.1N  $\text{FeSO}_4$   
=  $30 \times 0.1 = 3$  m. eq.

According to problem step (iv)

25 ml of  $\text{KMnO}_4$  reacts with = 3 m eq of  $\text{FeSO}_4$

Thus in step (iii) of the problem,

$$50 \text{ ml of KMnO}_4 \text{ reacts with} = \frac{3}{25} \times 50 \text{ m.eq. of FeSO}_4 \\ = 6 \text{ meq of FeSO}_4$$

Milli eq. of 100 ml of 0.1N FeSO<sub>4</sub> = 100 × 0.1 = 10 m eq.

FeSO<sub>4</sub> which reacted with Mn<sub>3</sub>O<sub>4</sub> = (10–6) = 4 m eq.

Milli eq of FeSO<sub>4</sub> = Milli eq. of Mn<sub>3</sub>O<sub>4</sub>

(∵ Milli eq of oxidising agent and reducing agent are equal)

$$\therefore \text{Mn}_3\text{O}_4 \equiv 3\text{MnSO}_4 \cdot 4\text{H}_2\text{O}$$

$$\therefore 1 \text{ Meq of Mn}_3\text{O}_4 = 3 \text{ Meq of MnSO}_4 \cdot 4\text{H}_2\text{O}$$

$$\therefore 4 \text{ Meq of Mn}_3\text{O}_4 = 12 \text{ Meq of MnSO}_4 \cdot 4\text{H}_2\text{O}$$

$$\text{Eq. wt of MnSO}_4 \cdot 4\text{H}_2\text{O} = \frac{\text{Mol. wt.}}{2} = \frac{223}{2} = 111.5$$

$$\text{Wt of MnSO}_4 \cdot 4\text{H}_2\text{O in sample} = 12 \times 111.5 \\ = 1338 \text{ mg} = \mathbf{1.338g.}$$

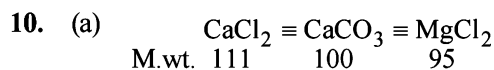

From this it is evident, that

111 mg CaCl<sub>2</sub> will give CaCO<sub>3</sub> = 100mg

$$\therefore 1 \text{ mg CaCl}_2 \text{ will give CaCO}_3 = \frac{100}{111} \text{ mg} = 0.90 \text{ mg}$$

95 mg MgCl<sub>2</sub> gives CaCO<sub>3</sub> = 100 mg

$$\therefore 1 \text{ mg MgCl}_2 \text{ gives CaCO}_3 = \frac{100}{95} \text{ mg} = 1.05 \text{ mg}$$

∴ Total CaCO<sub>3</sub> formed by 1 mg CaCl<sub>2</sub> and 1 mg MgCl<sub>2</sub>  
= 0.90 + 1.05 = 1.95 mg

∴ Amount of CaCO<sub>3</sub> present per litre of water = 1.95mg

∴ wt of 1 ml of water = 1g = 10<sup>3</sup> mg

∴ wt of 1000 ml of water = 10<sup>3</sup> × 10<sup>3</sup> = 10<sup>6</sup>mg

∴ Total hardness of water in terms of parts of CaCO<sub>3</sub>  
per 10<sup>6</sup> parts of water by weight = **1.95 parts.**

(b)  $\text{Eq wt of Ca}^{++} = \frac{\text{Mol. wt}}{\text{Charge}} = \frac{40}{2} = 20$

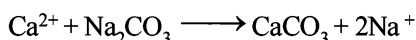

1 milliequivalent of Ca<sup>2+</sup> = 20 mg

**1 milliequivalent** of Na<sub>2</sub>CO<sub>3</sub> is required to soften 1 litre of hard water.

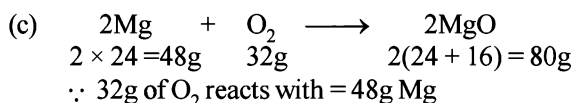

$$\therefore 0.5\text{g of O}_2 \text{ reacts with} = \frac{48}{32} \times 0.5 = 0.75\text{g}$$

Weight of unreacted Mg = 1.00 – 0.75 = 0.25g

Thus Mg is left in excess.

$$\text{Weight of MgO formed} = \frac{80}{48} \times 0.75 = 1.25\text{g}$$

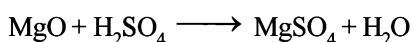

(40g)

According to reaction

∴ 40g MgO is dissolved it gives 1000 ml of 1 N. H<sub>2</sub>SO<sub>4</sub>

∴ 40 g MgO is dissolved it gives 2000 ml 0.5 N H<sub>2</sub>SO<sub>4</sub>

∴ 1.25 MgO is dissolved it gives

$$= \frac{2000 \times 1.25}{40} \text{ ml of } 0.5 \text{ N H}_2\text{SO}_4$$

= **62.5ml of 0.5N H<sub>2</sub>SO<sub>4</sub>**

11. Given  $P = 1 \text{ atm}$   $V = 1\text{L}$ ,  $T = 127^\circ\text{C} = 127 + 273 = 400 \text{ K}$   
 $PV = nRT$  (Ideal gas equation)

$$\text{or } n = \frac{PV}{RT} = \frac{1 \times 1}{0.082 \times 400} = 0.0304$$

$$\text{Mol. wt} = \frac{\text{Mass}}{\text{Moles}} = \frac{2.8}{0.0304} = 92.10$$

Element	wt. of element	Relative no. of atoms	Ratio of atoms	Whole no. of atoms
C	10.5	$\frac{10.5}{12} = 0.875$	$\frac{0.875}{0.875} = 1$	$1 \times 7 = 7$
H	1.0	$\frac{1.0}{1} = 1$	$\frac{1}{0.875} = 1.14$	$1.14 \times 7 = 8$

∴ Empirical formula = C<sub>7</sub>H<sub>8</sub>

Empirical formula, wt = 12 × 7 + 1 × 8 = 92

$$n = \frac{\text{Molecular wt}}{\text{Empirical formula wt}} = \frac{92.10}{92} = 1$$

Molecular formula = n × empirical formula  
= 1(C<sub>7</sub>H<sub>8</sub>) = C<sub>7</sub>H<sub>8</sub>

12. (i) No. of C atoms in 14g of <sup>14</sup>C = 6.02 × 10<sup>23</sup>  
∴ No. of C atom in 7 mg (7/1000g) of <sup>14</sup>C

$$= \frac{6.02 \times 10^{23} \times 7}{14 \times 1000} = 3.01 \times 10^{20}$$

No. of neutrons in 1 carbon atom = 7

∴ Total no. of neutrons in 7 mg of <sup>14</sup>C = 3.01 × 10<sup>20</sup> × 7  
= 21.07 × 10<sup>20</sup>

Wt of 1 neutron = wt of 1 hydrogen atom

$$= \frac{1}{6.02 \times 10^{23}} \text{ g}$$

∴ Wt of 3.01 × 10<sup>20</sup> × 7 neutrons

$$= \frac{3.0 \times 10^{20} \times 7}{6.02 \times 10^{23}} = \mathbf{3.5 \times 10^{-3} \text{ g}}$$

13. Weight of AgCl formed = 2.567 g

Amount of AgCl formed due to MCl = 1.341 g

(∵ NaCl does not decompose on heating to 300°C)

∴ Weight of AgCl formed due to NaCl

$$= 2.567 - 1.341 = 1.226\text{g}$$



58.5    143.5

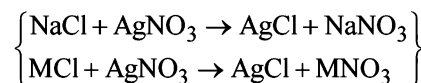

∴ 143.5g of AgCl is obtained from NaCl = 58.5g

∴ 1.226 g of AgCl is obtained from NaCl

$$= \frac{58.5}{143.5} \times 1.226 = 0.4997 \text{ g}$$

∴ Wt of MCl in 1 g of mixture =  $1.000 - 0.4997 = 0.5003\text{g}$

∴ 1.341 g of AgCl is obtained from MCl = 0.5003g

∴ 143.5g of AgCl is obtained from MCl

$$= \frac{0.5003}{1.341} \times 143.5 = 53.53 \text{ g}$$

∴ Molecular weight of MCl = **53.53**

14. The complete oxidation under acidic conditions can be represented as follows:

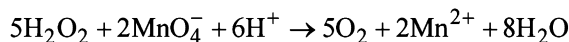

Since 34 g of  $\text{H}_2\text{O}_2 = 2000 \text{ ml}$  of 1N  $\text{H}_2\text{O}_2$

$$\left( \because \text{Eq. wt of } \text{H}_2\text{O}_2 = \frac{34}{2} \right)$$

∴ 34 g of  $\text{H}_2\text{O}_2 = 2000 \text{ ml}$  of 1N  $\text{KMnO}_4$  [ $\because N_1V_1 = N_2V_2$ ]

$$\text{or } \frac{X}{100} \text{ g of } \text{H}_2\text{O}_2 = \frac{2000 \times X}{100 \times 34} \text{ ml of 1N } \text{KMnO}_4$$

$$\text{Therefore the unknown normality} = \frac{2000 \times X}{34 \times 100 \times X}$$

$$= \frac{10}{17} \text{ or } \mathbf{0.588 \text{ N}}$$

15. Balance the reactions by ion electron method.

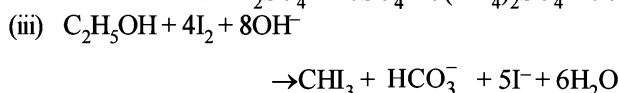
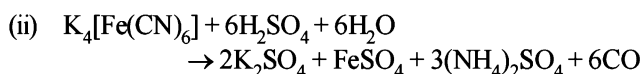
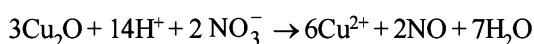
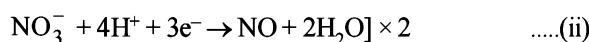
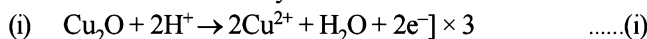

16. Given  $2\text{NH}_2\text{OH} + 4\text{Fe}^{3+} \rightarrow \text{N}_2\text{O} + \text{H}_2\text{O} + 4\text{Fe}^{2+} + 4\text{H}^+$  .....(i)

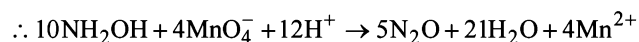
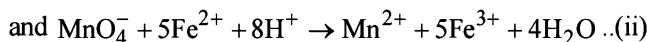

[On multiplying (i) by 5 and (ii) by 4 and then adding the resulting equations]

Molecular weight of  $\text{NH}_2\text{OH} = 33$

Thus 4000 ml of 1M  $\text{MnO}_4^-$  would react with  $\text{NH}_2\text{OH} = 330\text{g}$

∴ 12 ml of 0.02 M  $\text{KMnO}_4$  would react with  $\text{NH}_2\text{OH}$

$$= \frac{330 \times 12 \times 0.02}{400} \text{ g}$$

$$\therefore \text{Amount of } \text{NH}_2\text{OH} \text{ present in } 1000 \text{ ml of diluted solution} = \frac{330 \times 12 \times 0.02 \times 1000}{4000 \times 50} \text{ g}$$

Since 10 ml of sample of hydroxylamine is diluted to one litre

∴ Amount of hydroxyl amine in one litre of original solution

$$= \frac{330 \times 0.02 \times 12 \times 1000}{4000 \times 50} \times \frac{1000}{10} \text{ g} = \mathbf{39.6 \text{ g}}$$

#### 17. TIPS/Formulae :

$$(i) \text{ Mole fraction} = \frac{\text{Moles of substance}}{\text{Total moles}}$$

(ii) 1 mole of  $\text{Na}_2\text{S}_2\text{O}_3$  gives 2 moles of  $\text{Na}^+$  and 1 mole of  $\text{S}_2\text{O}_3^{2-}$

Molecular wt. of sodium thiosulphate solution ( $\text{Na}_2\text{S}_2\text{O}_3$ ) =  $23 \times 2 + 32 \times 2 + 16 \times 3 = 158$

(i) The percentage by weight of  $\text{Na}_2\text{S}_2\text{O}_3$

$$= \frac{\text{wt of } \text{Na}_2\text{S}_2\text{O}_3}{\text{wt of solution}} \times 100 = \frac{3 \times 158 \times 100}{1000 \times 1.25} = \mathbf{37.92}$$

[Wt. of  $\text{Na}_2\text{S}_2\text{O}_3 = \text{Molarity} \times \text{Mol wt}$ ]

(ii) Mass of 1 litre solution =  $1.25 \times 1000 \text{ g} = 1250 \text{ g}$

[∵ density = 1.25g/l]

Mole fraction of  $\text{Na}_2\text{S}_2\text{O}_3$

$$= \frac{\text{Number of moles of } \text{Na}_2\text{S}_2\text{O}_3}{\text{Total number of moles}}$$

$$\text{Moles of water} = \frac{1250 - 158 \times 3}{18} = 43.1$$

$$\text{Mole fraction of } \text{Na}_2\text{S}_2\text{O}_3 = \frac{3}{3 + 43.1} = 0.065$$

(iii) 1 mole of sodium thiosulphate ( $\text{Na}_2\text{S}_2\text{O}_3$ ) yields 2 moles of  $\text{Na}^+$  and 1 mole of  $\text{S}_2\text{O}_3^{2-}$ .

$$\text{Molality of } \text{Na}_2\text{S}_2\text{O}_3 = \frac{3 \times 1000}{776} = 3.87$$

$$\text{Molality of } \text{Na}^+ = 3.87 \times 2 = \mathbf{7.74 \text{ m}}$$

$$\text{Molality of } \text{S}_2\text{O}_3^{2-} = \mathbf{3.87 \text{ m}}$$

18. Weight of  $\text{MCO}_3$  and  $\text{BaO} = 4.08 \text{ g}$  (given)

Weight of residue = 3.64 g (given)

$$\therefore \text{Weight of } \text{CO}_2 \text{ evolved on heating} = (4.08 - 3.64) \text{ g} = 0.44 \text{ g}$$

$$= \frac{0.44}{44} = 0.01 \text{ mole}$$

Number of moles of  $\text{MCO}_3 \equiv 0.01 \text{ mole}$

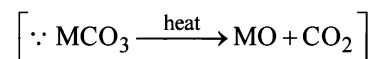

Volume of 1N HCl in which residue is dissolved = 100 ml

Volume of 1N HCl used for dissolution =  $(100 - 2.5 \times 16) \text{ ml} = 60 \text{ ml}$

$$= \frac{60}{1000} = 0.06 \text{ equivalents}$$



The chemical equation for dissolution can be written as

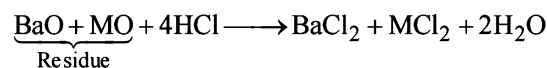

[Number of moles of BaO and MO = 1 + 1 = 2]

$$\begin{aligned} \text{Number of moles of BaO} + \text{Number of moles of MO} &= \frac{0.06}{2} \\ &= 0.03 \end{aligned}$$

Number of moles of BaO = (0.03 - 0.01) = 0.02 moles

Molecular weight of BaO = 138 + 16 = 154

∴ Weight of BaO = (0.02 × 154) g = 3.08 g

Weight of MCO<sub>3</sub> = (4.08 - 3.08) = 1.0 g

Since weight of 0.01 mole of MCO<sub>3</sub> = 1.0 g

$$\therefore \text{Mol. wt. of MCO}_3 = \frac{1}{0.01} = 100$$

Hence atomic weight of unknown M = (100 - 60) = 40

The atomic weight of metal is 40 so the metal M is Ca.

### 19. TIPS/Formulae :

Balance the atoms as well as charges by ion electron/oxidation number method.

While balancing the equations, both the charges and atoms must balance.

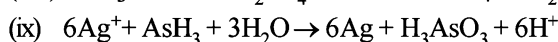
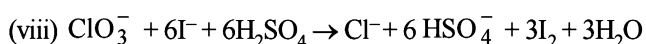
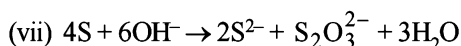
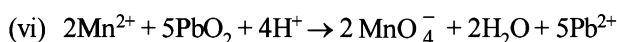
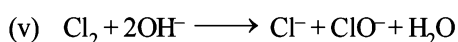
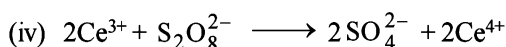
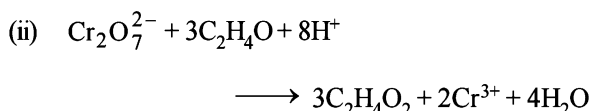
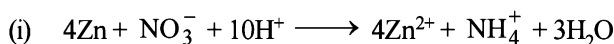

### 20. TIPS/Formulae :

Equivalents of A oxidised = Equivalents of A reduced.

Since in acidic medium, A<sup>n+</sup> is oxidised to AO<sub>3</sub><sup>-</sup>, the change in oxidation state from

$$(+5) \text{ to } (+n) = 5 - n \quad [\because \text{O.S. of A in AO}_3^- = +5]$$

∴ Total number of electrons that have been given out during oxidation of 2.68 × 10<sup>-3</sup> moles of A<sup>n+</sup>

$$= 2.68 \times 10^{-3} \times (5 - n)$$

Thus the number of electrons added to reduce 1.61 × 10<sup>-3</sup> moles of MnO<sub>4</sub><sup>-</sup> to Mn<sup>2+</sup>, i.e.

$$(+7) \text{ to } (+2) = 1.61 \times 10^{-3} \times 5$$

[Number of electrons involved = +7 - (+2) = 5]

$$\therefore 1.61 \times 10^{-3} \times 5 = 2.68 \times 10^{-3} \times (5 - n)$$

$$5 - n = \frac{1.61 \times 5}{2.68} \quad \text{or} \quad n = 5 - \frac{8.05}{2.68} \approx 2$$

### 21. TIPS/Formulae :

(i) Find normality of acid mixture and Na<sub>2</sub>CO<sub>3</sub> · 10H<sub>2</sub>O. Equate them to find volume of H<sub>2</sub>SO<sub>4</sub>.

$$(ii) \quad \text{Meq. of H}_2\text{SO}_4 = V \times N = \frac{V \times N}{1000} \text{ eq.}$$

(iii) Equivalent of SO<sub>4</sub><sup>2-</sup> = equivalents of H<sub>2</sub>SO<sub>4</sub> × Eq. wt. of SO<sub>4</sub><sup>2-</sup>

N × V (ml.) = meq.

Acid mixture contains 5 ml of 8N, HNO<sub>3</sub>, 4.8 ml of 5N, HCl and say, 'V' ml of 17 M ≡ 34 N, H<sub>2</sub>SO<sub>4</sub>.

$$[1\text{MH}_2\text{SO}_4 = 2\text{N.H}_2\text{SO}_4]$$

$$N \text{ of the acid mixture} = \frac{\text{meq. (total) of acid}}{\text{ml. of solution}}$$

$$= \frac{5 \times 8 + 4.8 \times 5 + V \times 34}{2000} \quad [\text{Total volume} = 2 \text{ L} = 2000 \text{ ml}]$$

$$\text{or, } N_{\text{mixture}} = \frac{64 + 34V}{2000}$$

$$\begin{aligned} \therefore \text{Eq. of wt. of Na}_2\text{CO}_3 \cdot 10\text{H}_2\text{O} &= \frac{\text{Mol. wt.}}{2} \\ &= \frac{106 + 180}{2} = 143 \end{aligned}$$

$$N \text{ of Na}_2\text{CO}_3 = \frac{\text{Meq. of Na}_2\text{CO}_3}{\text{Volume of solution (ml)}}$$

$$\begin{aligned} &= \frac{1}{100} = \frac{1}{143} \times \frac{1000}{100} = 0.069\text{N} \end{aligned}$$

$$N_1V_1 = N_2V_2$$

$$\text{or } 30 \times N_{\text{mixture}} = 42.9 \times 0.069$$

(acid) (sod. carbonate)

$$\therefore N_{\text{mixture}} = \frac{42.9 \times 0.069}{30} = 0.0986 \text{ N}$$

$$\text{Hence } \frac{64 + 34V}{2000} = 0.0986$$

$$64 + 34V = 0.0986 \times 2000, \quad 64 + 34V = 197.2$$

$$34V = 197.2 - 64.0 = 133.2 \quad \therefore \text{or } V = \frac{133.2}{34} = 3.9 \text{ ml.}$$

$$\begin{aligned} \text{Hence meq. of H}_2\text{SO}_4 &= V \times N \text{ of H}_2\text{SO}_4 \\ &= 3.9 \times 34 = 132.6 \text{ meq.} \\ &= 0.1326 \text{ eq. of H}_2\text{SO}_4 \\ &= 0.1326 \text{ eq. of SO}_4^{2-} \\ &= 0.1326 \times 48 \text{ g of SO}_4^{2-} \end{aligned}$$

$$\left( \because \text{Eq. wt. of } \text{SO}_4^{2-} = \frac{32 + 64}{2} = 48 \right)$$

= 6.3648 g of  $\text{SO}_4^{2-}$  are in 3.9 ml of 17M  $\text{H}_2\text{SO}_4$

22.  $\text{HI} < \text{I}_2 < \text{ICl} < \text{HIO}_4$ ; O.N. of I in  $\text{I}_2 = 0$ ,  $\text{HI} = -1$ ,  $\text{ICl} = +1$ ,  $\text{HIO}_4 = +7$ .

23. (i) From the given half-cell reaction,

$$\text{Here Eq. wt. of } \text{NaBrO}_3 = \frac{\text{Mol. wt.}}{6} = \frac{151}{6} = 25.17$$

[ $\because$  number of electron involved = 6]

Now we know that

$$\text{Meq.} = \text{Normality} \times \text{Vol. in ml.} = 85.5 \times 0.672 = 57.456$$

$$\text{Also Meq.} = \frac{W_{\text{NaBrO}_3}}{\text{Eq. wt. NaBrO}_3} \times 1000$$

$$= \frac{W_{\text{NaBrO}_3}}{25.17} \times 1000$$

$$\frac{W_{\text{NaBrO}_3}}{25.17} \times 1000 = 57.456 \text{ g}$$

$$\therefore W_{\text{NaBrO}_3} = 1.446 \text{ g}$$

$$\text{Molarity of } \text{NaBrO}_3 = \frac{\text{Normality}}{\text{Valence factor}}$$

$$= \frac{0.672}{6} = 0.112 \text{ M}$$

(ii) From the given half-cell reaction,

$$\text{Eq. wt. of } \text{NaBrO}_3 = \frac{\text{Mol. wt.}}{5} = \frac{151}{5} = 30.2$$

$$[\text{Number of electron involved per } \text{BrO}_3^- = \frac{10}{2} = 5]$$

Thus, the amount of  $\text{NaBrO}_3$  required for preparing 1000 ml. of 1 N  $\text{NaBrO}_3 = 30.2 \text{ g}$

$\therefore$  The amount of  $\text{NaBrO}_3$  required for preparing 85.5 ml of 0.672 N  $\text{NaBrO}_3$ .

$$= \frac{30.2 \times 0.672 \times 85.5}{1000} = 1.7532 \text{ g}$$

$$\text{Hence, Molarity} = \frac{0.672}{5} = 0.1344 \text{ M}$$

24. (i) Weight of sugar syrup = 214.2 g  
Weight of sugar in the syrup = 34.2 g  
 $\therefore$  Weight of water in the syrup = 214.2 - 34.2 = 180.0 g  
Mol. wt. of sugar,  $\text{C}_{12}\text{H}_{22}\text{O}_{11} = 342$

$$\therefore \text{Molal concentration} = \frac{34.2 \times 1000}{342 \times 180} = 0.56$$

(ii) Mol. wt. of water,  $\text{H}_2\text{O} = 18$

$$\therefore \text{Mole fraction of sugar} = \frac{34.2/342}{180/18 + 34.2/342}$$

$$= \frac{0.1}{10 + 0.1} = \frac{0.1}{10.1} = 0.0099$$

25. TIPS/Formulae :

No. of equivalents of  $\text{KMnO}_4$

= No. of equivalents of hydrazine sulphate.

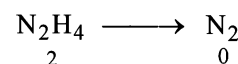

Change in oxidation state for each  $\text{N}_2\text{H}_4 = 2 \times 2 = 4$

$$\text{Equivalent weight of } \text{N}_2\text{H}_6\text{SO}_4 = \frac{130}{4} = 32.5$$

Normality of  $\text{KMnO}_4 = 5 \times 450$  ( $\because$  valence factor = 5)

$$\text{Number of equivalents of } \text{KMnO}_4 = 20 \times \frac{5}{50 \times 1000} = \frac{1}{500}$$

and if weight of hydrazin sulphate be  $x$  gm then equivalents

$$\text{of hydrazine sulphate} = \frac{x}{32.5}$$

$$\therefore \frac{1}{500} = \frac{x}{32.5} \text{ or } x = \frac{32.5}{500} = 0.065 \text{ g}$$

Hence wt. of  $\text{N}_2\text{H}_6\text{SO}_4$  in 10 ml solution = 0.065 g

$\therefore$  Wt. of  $\text{N}_2\text{H}_6\text{SO}_4$  in 1000 ml solution = 6.5 g

26. TIPS/Formulae :

No. of equivalents of  $\text{KMnO}_4$  in neutral medium

= No. of equivalents of reducing agent.

Assuming that  $\text{KMnO}_4$  shows the following changes during its oxidising nature.

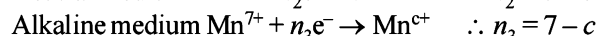
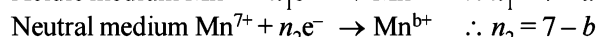
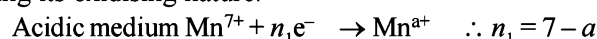

Let  $V$  ml. of reducing agent be used for  $\text{KMnO}_4$  in different medium.

$\therefore$  Meq. of reducing agent

= Meq. of  $\text{KMnO}_4$  in acid medium

Meq. of  $\text{KMnO}_4$  in neutral medium

= Meq. of  $\text{KMnO}_4$  in alkaline medium

$$= 1 \times n_1 \times 20 = 1 \times n_2 \times 33.4 = 1 \times n_3 \times 100$$

$$= n_1 = 1.667 n_2 = 5 n_3$$

Since  $n_1, n_2$  and  $n_3$  are integers and  $n_1$  is not greater than 7

$$\therefore n_3 = 1$$

Hence  $n_1 = 5$  and  $n_2 = 3$

$\therefore$  Different oxidation states of Mn in

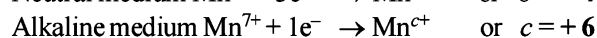
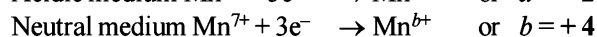
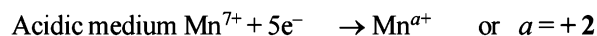

Further, same volume of reducing agent is treated with  $\text{K}_2\text{Cr}_2\text{O}_7$ , and therefore

Meq. of reducing agent = Meq. of  $\text{K}_2\text{Cr}_2\text{O}_7$



$$V = 16.66 \text{ mL} \therefore 1\text{M} = 6 \times 1\text{N}$$

**27. TIPS/Formulae :**

No. of equivalents of  $\text{KMnO}_4$   
= No. of equivalents of reducing agents.

**Case I.** Reaction of  $\text{NaOH}$  with  $\text{H}_2\text{C}_2\text{O}_4$  and  $\text{NaHC}_2\text{O}_4$ .



Number of milliequivalents of  $\text{NaOH} = N \times V = 3.0 \times 0.1 = 0.3$

$\therefore$  Combined normality of the mixture titrated with  $\text{NaOH}$

$$= \frac{0.3}{10} = 0.03$$

**Case II.** Reaction of  $\text{C}_2\text{O}_4^{2-}$  ion and  $\text{KMnO}_4$

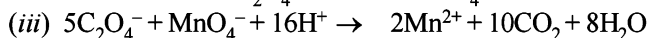

$\text{KMnO}_4$  will react in same manner with both  $\text{NaHC}_2\text{O}_4$  and  $\text{H}_2\text{C}_2\text{O}_4$  as it can be seen from the above reaction.

Number of milliequivalents of  $\text{KMnO}_4 = 4.0 \times 0.1 = 0.4$

$\therefore$  Combined normality of the mixture titrated with  $\text{KMnO}_4$

$$= \frac{0.4}{10} = 0.04$$

The difference ( $0.04 \text{ N} - 0.03 \text{ N} = 0.01 \text{ N}$ ) is due to  $\text{NaHC}_2\text{O}_4$

The total normality of  $\text{NaHC}_2\text{O}_4$  will be  $= 0.01 + 0.01 = 0.02 \text{ N}$

From equation (ii) in case I.

Eq. wt. of  $\text{NaHC}_2\text{O}_4 = 112$

Amount of  $\text{NaHC}_2\text{O}_4$  in one litre of solution formed

$$= 0.01 \times 112 = \mathbf{1.12 \text{ g}}$$
 and amount of  $\text{H}_2\text{C}_2\text{O}_4$

$$= 2.02 - \text{Wt. of } \text{NaHC}_2\text{O}_4 = 2.02 - 1.12 = \mathbf{0.90 \text{ g}}$$

**28. TIPS/Formulae :**

Let the amount of  $\text{NaNO}_3$  in the mixture =  $x \text{ g}$

$\therefore$  The amount of  $\text{Pb}(\text{NO}_3)_2$  in the mixture =  $(5 - x) \text{ g}$

Heating effect of sodium nitrate and lead nitrate

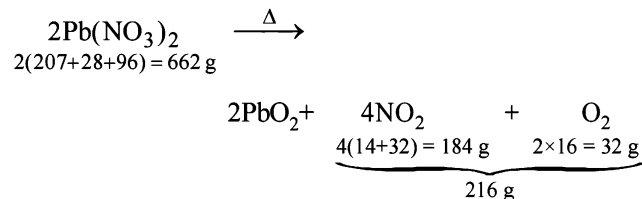
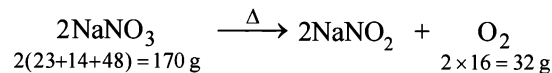

Now since,  $170 \text{ g}$  of  $\text{NaNO}_3$  gives  $= 32 \text{ g}$  of  $\text{O}_2$

$$\therefore x \text{ g of } \text{NaNO}_3 \text{ gives} = \frac{32}{170} \times x \text{ g of } \text{O}_2$$

Similarly,  $662 \text{ g}$  of  $\text{Pb}(\text{NO}_3)_2$  gives  $= 216 \text{ g}$  of gases  
( $\text{NO}_2 + \text{O}_2$ )

$$(5 - x) \text{ g of } \text{Pb}(\text{NO}_3)_2 \text{ gives} = \frac{216}{662} \times (5 - x) \text{ g of gases}$$

( $\text{NO}_2 + \text{O}_2$ )

Actual loss, on heating, is  $28\%$  of  $5 \text{ g}$  of mixture

$$= \frac{5 \times 28}{100} = 1.4 \text{ g}$$

$$\therefore \frac{32x}{170} + \frac{216}{662} \times (5 - x) = 1.4$$

$$32x \times 662 + 216(5 - x) \times 170 = 1.4 \times 170 \times 662$$

$$21184x + 183600 - 36720x = 157556$$

$$-15536x = -26044, x = 1.676 \text{ g}$$

Wt. of  $\text{NaNO}_3 = \mathbf{1.676 \text{ g}}$

and Wt. of  $\text{Pb}(\text{NO}_3)_2 = 5 - 1.676 \text{ g} = \mathbf{3.324 \text{ g}}$

**29. TIPS/Formulae :**

$$\text{Molality} = \frac{\text{Mass of solute / M. wt. of solute}}{\text{Mass of solvent in kg}}$$

Mass of  $\text{H}_2\text{SO}_4$  in  $100 \text{ ml}$  of  $93\%$   $\text{H}_2\text{SO}_4$  solution  $= 93 \text{ g}$

$\therefore$  Mass of  $\text{H}_2\text{SO}_4$  in  $1000 \text{ ml}$  of the  $\text{H}_2\text{SO}_4$  solution  $= 930 \text{ g}$

Mass of  $1000 \text{ ml}$   $\text{H}_2\text{SO}_4$  solution  $= 1000 \times 1.84 = 1840 \text{ g}$

Mass of water in  $1000 \text{ ml}$  of solution  $= 1840 - 930 \text{ g}$   
 $= 910 \text{ g} = 0.910 \text{ kg}$

$$\text{Moles of } \text{H}_2\text{SO}_4 = \frac{\text{Wt. of } \text{H}_2\text{SO}_4}{\text{Mol. wt. of } \text{H}_2\text{SO}_4} = \frac{930}{98}$$

$\therefore$  Moles of  $\text{H}_2\text{SO}_4$  in  $1 \text{ kg}$  of water

$$= \frac{930}{98} \times \frac{1}{0.910} = 10.43 \text{ mol}$$

$\therefore$  Molality of solution  $= \mathbf{10.43 \text{ m}}$

**30.** In the given problem, a solution containing  $\text{Cu}^{2+}$  and

$\text{C}_2\text{O}_4^{2-}$  is titrated first with  $\text{KMnO}_4$  and then with  $\text{Na}_2\text{S}_2\text{O}_3$

in presence of  $\text{KI}$ . In titration with  $\text{KMnO}_4$ , it is the  $\text{C}_2\text{O}_4^{2-}$  ions that react with the  $\text{MnO}_4^-$  ions. The concerned balanced equation may be written as given below.

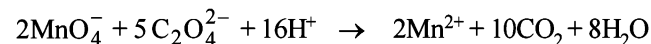

Thus according to the above reaction

$$2 \text{ mmol } \text{MnO}_4^- \equiv 5 \text{ mmol } \text{C}_2\text{O}_4^{2-}$$

However,

No. of mmol of  $\text{MnO}_4^-$  used in titration = Vol. in ml  $\times$  M

$$= 22.6 \times 0.02 = 0.452 \text{ mmol } \text{MnO}_4^-$$

Since  $2 \text{ mmol } \text{MnO}_4^- \equiv 5 \text{ mmol } \text{C}_2\text{O}_4^{2-}$

$$0.452 \text{ mmol } \text{MnO}_4^- \equiv \frac{5}{2} \times 0.452 = 1.130 \text{ mmol } \text{C}_2\text{O}_4^{2-}$$

*Titration with  $\text{Na}_2\text{S}_2\text{O}_3$  in the presence of  $\text{KI}$ .*

Here  $\text{Cu}^{2+}$  react and the reactions involved during titration are

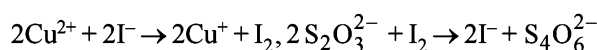

Thus  $2\text{Cu}^{2+} \equiv \text{I}_2 \equiv 2\text{S}_2\text{O}_3^{2-}$

No. of mmol of  $\text{S}_2\text{O}_3^{2-}$  used in titration

$$= 0.05 \times 11.3 = 0.565 \text{ mmol } \text{S}_2\text{O}_3^{2-}$$

Now since  $2 \text{ mmol } \text{S}_2\text{O}_3^{2-} \equiv 2 \text{ mmol } \text{Cu}^{2+}$  [From above equation]

$$0.565 \text{ mmol } \text{S}_2\text{O}_3^{2-} = \frac{2}{2} \times 0.565 \text{ mmol } \text{Cu}^{2+} \\ = 0.565 \text{ mmol } \text{Cu}^{2+}$$

$$\therefore \text{Molar ratio of } \text{Cu}^{2+} \text{ to } \text{C}_2\text{O}_4^{2-} = \frac{0.565 \text{ mmol}}{1.130 \text{ mmol}} = 1 : 2$$

Balanced equations in two cases

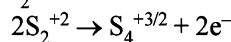
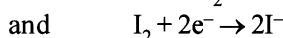
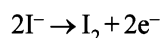
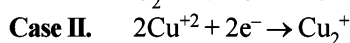
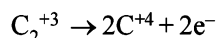
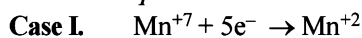

31. Mass of  $\text{Fe}_2\text{O}_3$  in the sample =  $\frac{55.2}{100} \times 1 = 0.552 \text{ g}$

$$\text{Number of moles of } \text{Fe}_2\text{O}_3 = \frac{0.552}{159.8} = 3.454 \times 10^{-3}$$

$$\text{Number of moles of } \text{Fe}^{3+} \text{ ions} = 2 \times 3.454 \times 10^{-3} \\ = 6.9 \times 10^{-3} \text{ mol} = 6.90 \text{ mmol}$$

Since its only 1 electron is exchanged in the conversion of  $\text{Fe}^{3+}$  to  $\text{Fe}^{2+}$ , the molecular mass is the same as equivalent mass.

$$\therefore \text{Amount of } \text{Fe}^{2+} \text{ ion in 100 ml. of sol.} = 6.90 \text{ meq}$$

$$\text{Volume of oxidant used for 100 ml of } \text{Fe}^{2+} \text{ sol.} \\ = 17 \times 4 = 68 \text{ ml.}$$

$$\text{Amount of oxidant used} = 68 \times 0.0167 \text{ mmol} \\ = 1.1356 \text{ mmol}$$

Let the number of electrons taken by the oxidant =  $n$

$$\therefore \text{No. of meq. of oxidant used} = 1.1356 \times n$$

$$\text{Thus } 1.1356 \times n = 6.90 \Rightarrow n = \frac{6.90}{1.1356} = 6$$

32. 1.5 g of sample require = 150 ml. of  $\frac{M}{10}$  HCl

$$\therefore 2 \text{ g of sample require} = \frac{150 \times 2}{1.5} \text{ ml. of } \frac{M}{10} \text{ HCl}$$

$$= 200 \text{ ml. of } \frac{M}{10} \text{ HCl}$$

On heating, the sample, only  $\text{NaHCO}_3$  undergoes decomposition as given below.

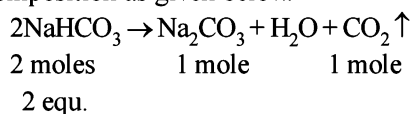

Neutralisation of the sample with HCl takes place as given below.

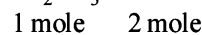
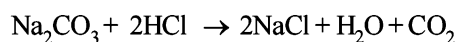
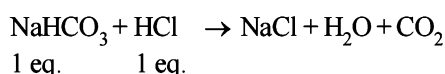

Hence, 2 g sample  $\equiv$  200 ml. of M/10 HCl

$$= 200 \text{ ml. of N/10 HCl} = 20 \text{ meq} = 0.020 \text{ eq}$$

Number of moles of  $\text{CO}_2$  formed, i.e.

$$n = \frac{PV}{RT} = \frac{750}{760} \times \frac{123.9}{1000} \times \frac{1}{0.082 \times 298} = 0.005$$

Moles of  $\text{NaHCO}_3$  in the sample (2 g) =  $2 \times 0.005 = 0.01$

Equivalent of  $\text{NaHCO}_3 = 0.01$

$$\text{Wt. of } \text{NaHCO}_3 = 0.01 \times 84 = 0.84 \text{ g}$$

$$\% \text{ of } \text{NaHCO}_3 = \frac{0.84 \times 100}{2} = 42\%$$

Equivalent of  $\text{Na}_2\text{CO}_3 = 0.02 - 0.01 = 0.01$

$$\text{Wt. of } \text{Na}_2\text{CO}_3 = 0.01 \times 53 = 0.53 \text{ g}$$

$$\therefore \% \text{ of } \text{Na}_2\text{CO}_3 = \frac{0.53 \times 100}{2} = 26.5\%$$

$$\therefore \% \text{ of } \text{Na}_2\text{SO}_4 \text{ in the mixture} = 100 - (42 + 26.5) = 31.5\%$$

33. Reaction involved titration is

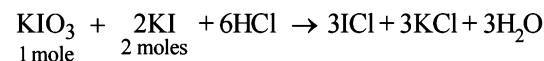

$$20 \text{ ml. of stock KI solution} \equiv 30 \text{ ml. of } \frac{M}{10} \text{ KIO}_3 \text{ solution}$$

$$\text{Molarity of KI solution} = \frac{30 \times 1 \times 2}{20 \times 10} = \frac{3}{10}$$

$$\text{Millimoles in 50 ml. of KI solution} = 50 \times \frac{3}{10} = 15$$

Millimoles of KI left unreacted with  $\text{AgNO}_3$  solution

$$= 2 \times 50 \times \frac{1}{10} = 10$$

$$\therefore \text{Millimoles of KI reacted with } \text{AgNO}_3 = 15 - 10 = 5$$

Millimoles of  $\text{AgNO}_3$  present in  $\text{AgNO}_3$  solution = 5

Molecular weight of  $\text{AgNO}_3 = 170$

$$\therefore \text{Wt. of } \text{AgNO}_3 \text{ in the solution} = 5 \times 10^{-3} \times 170 = 0.850 \text{ g}$$

$$\% \text{ AgNO}_3 \text{ in the sample} = \frac{0.850}{1} \times 100 = 85\%$$

34. Calculation of number of moles in 45 ml. of 0.025 M  $\text{Pb}(\text{NO}_3)_2$

$$\text{Moles of } \text{Pb}(\text{NO}_3)_2 = 0.025 \times \frac{45}{1000} = 0.01125$$

$$\therefore \text{Initial moles of } \text{Pb}^{2+} = 0.01125$$

$$\text{Moles of } \text{NO}_3^- = 0.01125 \times 2 = 0.02250$$

$$[1 \text{ mole } \text{Pb}(\text{NO}_3)_2 \equiv 2 \text{ moles of } \text{NO}_3^-]$$

Calculation of number of moles in 25 ml. of 0.1 M chromic sulphate

Moles of chromic sulphate ( $\text{Cr}_2(\text{SO}_4)_3$ )

$$= 0.1 \times \frac{25}{1000} = 0.0025 \text{ moles}$$

Moles of  $\text{SO}_4^{2-} = 0.0025 \times 3 = 0.0075$  [1 Mole of chromic sulphate  $\equiv$  3 moles of  $\text{SO}_4^{2-}$ ]

Moles of  $\text{PbSO}_4$  formed = **0.0075** [ $\text{SO}_4^{2-}$  is totally consumed]

Moles of  $\text{Pb}^{2+}$  left =  $0.01125 - 0.0075 = 0.00375$

Moles of  $\text{NO}_3^-$  left = 0.02250 [ $\text{NO}_3^-$  remain unreacted]

Moles of chromium ions =  $0.0025 \times 2 = 0.005$

Total volume of the solution =  $45 + 25 = 70$  ml.

$\therefore$  Molar concentration of the species left

$$(i) \text{Pb}^{2+} = \frac{0.00375}{70} \times 1000 = \mathbf{0.05357 \text{ M}}$$

$$(ii) \text{NO}_3^- = \frac{0.0225}{70} \times 1000 = \mathbf{0.3214 \text{ M}}$$

$$(iii) \text{Cr}^{3+} = \frac{0.005}{70} \times 1000 = \mathbf{0.0714 \text{ M}}$$

35. In pure iron oxide ( $\text{FeO}$ ), iron and oxygen are present in the ratio 1 : 1.

However, here number of  $\text{Fe}^{2+}$  present = 0.93

or No. of  $\text{Fe}^{2+}$  ions missing = 0.07

Since each  $\text{Fe}^{2+}$  ion has 2 positive charge, the total number of charge due to missing (0.07)  $\text{Fe}^{2+}$  ions =  $0.07 \times 2 = 0.14$

To maintain electrical neutrality, 0.14 positive charge is compensated by the presence of  $\text{Fe}^{3+}$  ions. Now since, replacement of one  $\text{Fe}^{2+}$  ion by one  $\text{Fe}^{3+}$  ion increases one positive charge, 0.14 positive charge must be compensated by the presence of 0.14  $\text{Fe}^{3+}$  ions.

In short, 0.93  $\text{Fe}^{2+}$  ions have 0.14  $\text{Fe}^{3+}$  ions

$$100 \text{ Fe}^{2+} \text{ ions have} = \frac{0.14}{0.93} \times 100 = \mathbf{15.05\%}$$

36. The formula of Glauber's salt is  $\text{Na}_2\text{SO}_4 \cdot 10\text{H}_2\text{O}$

Molecular mass of  $\text{Na}_2\text{SO}_4 \cdot 10\text{H}_2\text{O}$

$$= [2 \times 23 + 32.1 + 4 \times 16] + 10(1.01 \times 2 + 16) = 322.3 \text{ g mol}^{-1}$$

Weight of the Glauber's salt taken = 80.575 gm

Out of 80.575 g of salt, weight of anhydrous  $\text{Na}_2\text{SO}_4$

$$= \frac{142.1}{322.3} \times 80.575 = 35.525 \text{ g}$$

Number of moles of  $\text{Na}_2\text{SO}_4$  per  $\text{dm}^3$  of the solution

$$= \frac{35.525}{142.1} = 0.25$$

Molarity of the solution = **0.25 M**

Density of solution =  $1077.2 \text{ kgm}^{-3}$

$$= \frac{1077.2 \times 10^3}{10^6} \text{ gm cm}^{-3} = 1.0772 \text{ g cm}^{-3}$$

Total weight of sol =  $V \times d = 1 \text{ dm}^3 \times d$

$$= 1000 \text{ cm}^3 \times 1.0772 \text{ gm}^{-3} = 1077.2 \text{ g}$$

Weight of water =  $1077.2 - 35.525 = 1041.67 \text{ g}$

$$\text{Molality of sol.} = \frac{0.25}{1041.67 \text{ g}} \times 1000 \text{ g} = 0.2399 = \mathbf{0.24 \text{ m}}$$

$$\text{Number of moles of water in the solution} = \frac{1041.67}{18} = 57.87$$

Mole fraction of  $\text{Na}_2\text{SO}_4$

$$= \frac{\text{No. of moles of } \text{Na}_2\text{SO}_4}{\text{Total number of moles}} = \frac{0.25}{0.25 + 57.87} = 0.0043 = \mathbf{4.3 \times 10^{-3}}$$

### 37. TIPS/Formulae :

Find the milliequivalents and equate them as per data given in question.

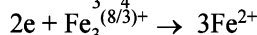
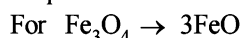

Thus, valence factor for  $\text{Fe}_3\text{O}_4$  is 2 and for  $\text{FeO}$  is 2/3.

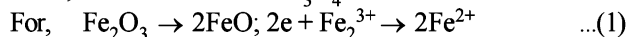

Thus valence factor for  $\text{Fe}_2\text{O}_3$  is 2 and for  $\text{FeO}$  is 1.

Let Meq. of  $\text{Fe}_3\text{O}_4$  and  $\text{Fe}_2\text{O}_3$  be  $a$  and  $b$  respectively.

$$\therefore \text{Meq. of } \text{Fe}_3\text{O}_4 + \text{Meq. of } \text{Fe}_2\text{O}_3 = \text{Meq. of } \text{I}_2 \text{ liberated} \\ = \text{Meq. of hypo used}$$

$$a + b = \frac{11 \times 0.5 \times 100}{20} = 27.5$$

Now, the  $\text{Fe}^{2+}$  ions are again oxidised to  $\text{Fe}^{3+}$  by  $\text{KMnO}_4$ .

Note that in the change

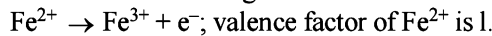

Thus,

$$\text{Meq. of } \text{Fe}^{2+} \text{ (from } \text{Fe}_3\text{O}_4) + \text{Meq. of } \text{Fe}^{2+} \text{ (from } \text{Fe}_2\text{O}_3) \\ = \text{Meq. of } \text{KMnO}_4 \text{ used} \quad \dots(2)$$

If valence factor for  $\text{Fe}^{2+}$  is 2/3 from Eq. (1),

then Meq. of  $\text{Fe}^{2+}$  (from  $\text{Fe}_3\text{O}_4$ ) =  $a$

If valence factor for  $\text{Fe}^{2+}$  is 1

then Meq. of  $\text{Fe}^{2+}$  (from  $\text{Fe}_3\text{O}_4$ ) =  $3a/2$   $\dots(3)$

Similarly, from Eq. (2), Meq. of  $\text{Fe}^{2+}$  from ( $\text{Fe}_2\text{O}_3$ ) =  $b$ .

$$\therefore 3a/2 + b = 0.25 \times 5 \times 12.8 \times 100/50 = 32$$

$$\text{or } 3a + 2b = 64 \quad \dots(4)$$

From Eqs. (3) and (4)

$$\text{Meq. of } \text{Fe}_3\text{O}_4 = a = 9 \text{ \& Meq. of } \text{Fe}_2\text{O}_3 = b = 18.5$$

$$\therefore W_{\text{Fe}_3\text{O}_4} = \frac{9 \times 232}{2 \times 1000} = 1.044 \text{ g}$$

$$\text{and } W_{\text{Fe}_2\text{O}_3} = \frac{18.5 \times 160}{2 \times 1000} = 1.48 \text{ g}$$

$$\therefore \% \text{ of } \text{Fe}_3\text{O}_4 = \frac{1.044 \times 100}{3} = \mathbf{34.8}$$

$$\text{and } \% \text{ of } \text{Fe}_2\text{O}_3 = \frac{1.48 \times 100}{3} = \mathbf{49.33}$$

### 38. TIPS/Formulae :

Write the reactions taking place, balance them and equate moles of  $\text{I}_2$  and  $\text{Na}_2\text{S}_2\text{O}_3$ .

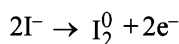
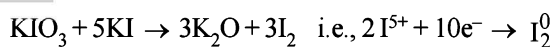

Now liberated  $\text{I}_2$  reacts with  $\text{Na}_2\text{S}_2\text{O}_3$

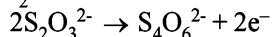
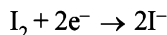

$\therefore$  millimole ratio of  $\text{I}_2 : \text{S}_2\text{O}_3 = 1 : 2$

Thus,  $m$  mole of  $\text{I}_2$  liberated

$$= m \text{ mole of } \text{Na}_2\text{S}_4\text{O}_6 \text{ used} \times \frac{1}{2} = 45 \times M \times \frac{1}{2}$$

[ $M$  is molarity of thiosulphate]

$$\text{Also } m \text{ mole of } \text{KIO}_3 = \frac{0.1}{214} \times 1000$$

Now  $m$  mole ratio of  $\text{KIO}_3 : \text{I}_2 = 1 : 3$

$$\text{Thus, } \frac{(0.1/214) \times 1000}{(45M/2)} = \frac{1}{3}$$

$$\therefore M = \frac{0.1 \times 1000 \times 3 \times 2}{214 \times 45} = \mathbf{0.062}$$

### 39. TIPS/Formulae :

Use molarity equation to find volume of  $\text{H}_2\text{SO}_4$  solution.

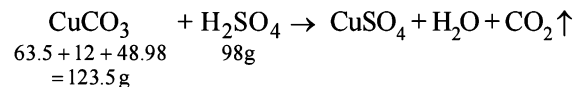

$\therefore$  For 123.5 gms of Cu(II) carbonate 98 g of  $\text{H}_2\text{SO}_4$  are required.  
For 0.5 gms of Cu(II) carbonate weight of  $\text{H}_2\text{SO}_4$  reqd.

$$= \frac{98 \times 0.5}{123.5} \text{ g} = 0.39676 \text{ g } \text{H}_2\text{SO}_4$$

Weight of required  $\text{H}_2\text{SO}_4 = 0.39676 \text{ g}$

Weight of solute in grams

$$= \frac{\text{Mol. wt.} \times \text{Molarity} \times \text{Volume in mL}}{1000}$$

$$0.39676 = \frac{98 \times 0.5 \times V}{1000} \quad \text{or} \quad V = \frac{0.39676 \times 1000}{90 \times 0.5} \text{ ml}$$

Volume of  $\text{H}_2\text{SO}_4$  solution = **8.097 ml**

### 40. TIPS/Formulae :

(i) Volume of virus =  $\pi r^2 \ell$  (Volume of cylinder)

(ii) Mass of single virus =  $\frac{\text{Volume}}{\text{Sp. volume}}$

(iii) Molecular mass of virus  
= Mass of single virus  $\times 6.02 \times 10^{23}$

Volume of virus =  $\pi r^2 \ell$

$$\begin{aligned} &= \frac{22}{7} \times \frac{150}{2} \times \frac{150}{2} \times 10^{-16} \times 5000 \times 10^{-8} \\ &= 0.884 \times 10^{-16} \text{ cm}^3 \end{aligned}$$

$$\begin{aligned} \text{Weight of one virus} &= \frac{0.884 \times 10^{-16}}{0.75} \text{ g} \\ &= 1.178 \times 10^{-16} \text{ g} \end{aligned}$$

$$\begin{aligned} \therefore \text{Mol. wt. of virus} &= 1.178 \times 10^{-16} \times 6.02 \times 10^{23} \\ &= \mathbf{7.09 \times 10^7} \end{aligned}$$

### 41. TIPS/Formulae :

Write the balanced chemical reaction for change and apply mole concept.

The given reactions are

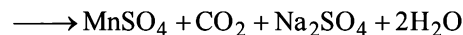
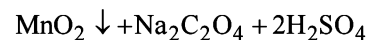

$$\therefore \text{Meq. of } \text{MnO}_2 \equiv \text{Meq. of } \text{Na}_2\text{C}_2\text{O}_4 = 10 \times 0.2 \times 2 = 4$$

$$\therefore \text{mM of } \text{MnO}_2 = \frac{4}{2} = 2 \quad \left[ \begin{array}{l} \text{Mn}^{4+} + 2\text{e}^- \rightarrow \text{Mn}^{2+} \\ \therefore \text{Valance factor of } \text{MnO}_2 = 2 \end{array} \right]$$

Now  $2\text{KMnO}_4 + 3\text{MnSO}_4 + 2\text{H}_2\text{O}$

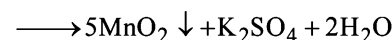

Since eq. wt. of  $\text{MnO}_2$  is derived from  $\text{KMnO}_4$  and  $\text{MnSO}_4$  both, thus it is better to proceed by mole concept

$$\text{mM of } \text{KMnO}_4 \equiv \text{mM of } \text{MnO}_2 \times (2/5) = 4/5$$

Also  $5\text{H}_2\text{O}_2 + 2\text{KMnO}_4 + 3\text{H}_2\text{SO}_4$

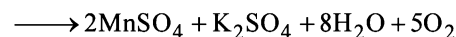

$$\therefore \text{mM of } \text{H}_2\text{O}_2 = \text{mM of } \text{KMnO}_4 \times \frac{5}{2} = \frac{4}{5} \times \frac{5}{2} = 2$$

$$\therefore M_{\text{H}_2\text{O}_2} \times 20 = 2 \quad \text{or} \quad M_{\text{H}_2\text{O}_2} = \mathbf{0.1}$$

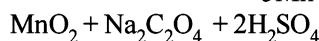
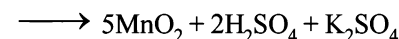

42. 1 litre water = 1 kg i.e. 1000 g water ( $\therefore d = 1000 \text{ kg/m}^3$ )

$$\equiv \frac{1000}{18} = 55.55 \text{ moles of water}$$

So, molarity of water = **55.55M**

### H. Assertion & Reason Type Questions

#### 1. (b) TIPS/Formulae :

Write reaction for titration between  $\text{Na}_2\text{CO}_3$  and  $\text{HCl}$ .

**Method :**

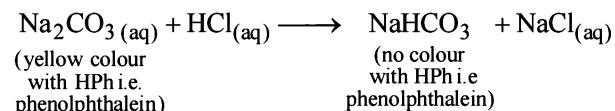

(Half neutralisation)

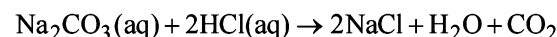

(Complete neutralisation)

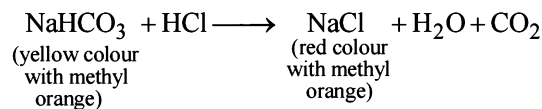

From these reaction it is clear that

- 2 moles of HCl are required for complete neutralization of  $\text{Na}_2\text{CO}_3$ .
  - Titre value using phenolphthalein corresponds only to neutralisation of  $\text{Na}_2\text{CO}_3$  to  $\text{NaHCO}_3$ , i.e. half of value required by  $\text{Na}_2\text{CO}_3$  solution.
  - Titre value using methyl orange corresponds to complete neutralisation of  $\text{Na}_2\text{CO}_3$ .
- $\therefore$  Both S and E are correct but S is not correct explanation of E.

### I. Integer Value Correct Type

1. The least significant figure in titre values is 3.

$$\text{Average titre value} = \frac{25.2 + 25.25 + 25}{3} = \frac{75.4}{3} = 25.1$$

The number of significant figures in average titre value will also be 3.

2.  $d = \frac{\text{mass}}{V} \Rightarrow 10.5 \text{ g/cc means in 1 cc}$

$\Rightarrow 10.5 \text{ g of Ag is present.}$

$$\text{Number of atoms of Ag in 1 cc} \Rightarrow \frac{10.5}{108} \times N_A$$

$$\text{In 1 cm, number of atoms of Ag} = \sqrt[3]{\frac{10.5}{108} N_A}$$

$$\text{In 1 cm}^2, \text{ number of atoms of Ag} = \left(\frac{10.5}{108} N_A\right)^{2/3}$$

In  $10^{-12} \text{ m}^2$  or  $10^{-8} \text{ cm}^2$ , number of atoms of Ag

$$= \left(\frac{10.5}{108} N_A\right)^{2/3} \times 10^{-8} = \left(\frac{10.5 \times 6.022 \times 10^{23}}{108}\right)^{2/3} \times 10^{-8} = 1.5 \times 10^7$$

Hence  $x = 7$

3. 5

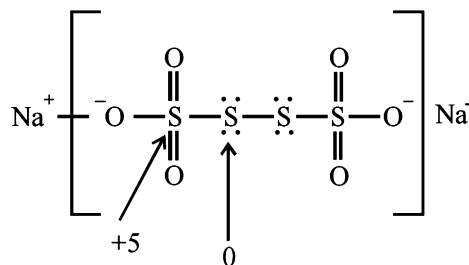

Difference in oxidation number =  $5 - 0 = 5$

4. 4  $R = N_A \times k$   
 $= 6.023 \times 10^{23} \times 1.380 \times 10^{-23}$   
 $= 8.312$  which has 4 significant figures

## Section-B JEE Main/ AIEEE

1.	(c)	Percentage	R.N.A	Simplest ratio
	C	9	$\frac{9}{12} = \frac{3}{4}$	3
	H	1	$\frac{1}{1} = 1$	4
	N	3.5	$\frac{3.5}{14} = \frac{1}{4}$	1

Empirical formula =  $\text{C}_3\text{H}_4\text{N}$

$$(\text{C}_3\text{H}_4\text{N})_n = 108, (12 \times 3 + 4 \times 1 + 14)_n = 108$$

$$(54)_n = 108 \Rightarrow n = \frac{108}{54} = 2$$

$\therefore$  molecular formula =  $\text{C}_6\text{H}_8\text{N}_2$

2. (c) Among all the given options molarity is correct because the term molarity involve volume which increases on increasing temperature.

3. (a)  $\text{Fe (no. of moles)} = \frac{558.5}{55.85} = 10 \text{ moles}$

C (no. of moles) in 60 g of C =  $60/12 = 5 \text{ moles.}$

4. (a)  $2\text{BCl}_3 + 3\text{H}_2 \rightarrow 2\text{B} + 6\text{HCl}$

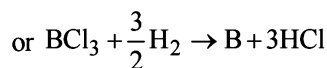

Now, since 10.8 gm boron requires hydrogen

$$= \frac{3}{2} \times 22.4 \text{ L at N.T.P}$$

hence 21.6 gm boron requires hydrogen

$$\frac{3}{2} \times \frac{22.4}{10.8} \times 21.6 = 67.2 \text{ L at N.T.P.}$$

5. (d)  $25 \times N = 0.1 \times 35$ ;  $N = 0.14$

$\text{Ba(OH)}_2$  is diacid base

$$\text{hence } N = M \times 2 \text{ or } M = \frac{N}{2} \Rightarrow M = 0.07 \text{ M}$$

6. (b) Moles of urea present in 100 ml of sol. =  $\frac{6.02 \times 10^{-20}}{6.02 \times 10^{23}}$

$$\therefore M = \frac{6.02 \times 10^{-20} \times 1000}{6.02 \times 10^{23} \times 100} = 0.01 \text{ M}$$

[ $\therefore M = \text{Moles of solute present in 1L of solution}$ ]

7. (a)  $N_1 V_1 = N_2 V_2$

(Note :  $H_3PO_3$  is dibasic  $\therefore M = 2N$ )

$$20 \times 0.2 = 0.1 \times V \quad (\text{Thus } 0.1 M = 0.2 N)$$

$$\therefore V = 40 \text{ ml}$$

8. (a)  $H_2SO_4$  is dibasic.

$$0.1 M H_2SO_4 = 0.2 N H_2SO_4 \quad [\because M = 2 \times N]$$

$$M_{eq} \text{ of } H_2SO_4 \text{ taken} = 100 \times 0.2 = 20$$

$$M_{eq} \text{ of } H_2SO_4 \text{ neutralised by NaOH} = 20 \times 0.5 = 10$$

$$M_{eq} \text{ of } H_2SO_4 \text{ neutralised by } NH_3 = 20 - 10 = 10$$

$$\% \text{ of } N_2 = \frac{1.4 \times M_{eq} \text{ of acid neutralised by } NH_3}{\text{wt. of organic compound}}$$

$$= \frac{1.4 \times 10}{0.3} = 46.6$$

$$\% \text{ of nitrogen in urea} = \frac{14 \times 2 \times 100}{60} = 46.6$$

[Mol. wt of urea = 60]

Similarly % of Nitrogen in Benzamide

$$= \frac{14 \times 100}{121} = 11.5\% \quad [C_6H_5CONH_2 = 121]$$

$$\text{Acetamide} = \frac{14 \times 1 \times 100}{59} = 23.4\% \quad [CH_3CONH_2 = 59]$$

$$\text{Thiourea} = \frac{14 \times 2 \times 100}{76} = 36.8\% \quad [NH_2CSNH_2 = 76]$$

Hence the compound must be urea.

9. (b) **TIPS/Formulae :**

From the molarity equation.

$$M_1 V_1 + M_2 V_2 = MV$$

Let M be the molarity of final mixture,

$$M = \frac{M_1 V_1 + M_2 V_2}{V} \text{ where } V = V_1 + V_2$$

$$M = \frac{480 \times 1.5 + 520 \times 1.2}{480 + 520} = 1.344 M$$

10. (d) Relative atomic mass

$$= \frac{\text{Mass of one atom of the element}}{1/12^{\text{th}} \text{ part of the mass of one atom of Carbon} - 12}$$

$$\text{or } \frac{\text{Mass of one atom of the element}}{\text{mass of one atom of the C} - 12} \times 12$$

Now if we use  $1/6$  in place of  $1/12$  the formula becomes

$$\text{Relative atomic mass} = \frac{\text{Mass of one atom of element}}{\text{Mass of one atom of carbon}} \times 6$$

$\therefore$  Relative atomic mass decrease twice

11. (d) 1 Mole of  $Mg_3(PO_4)_2$  contains 8 mole of oxygen atoms  
 $\therefore$  8 mole of oxygen atoms  $\equiv$  1 mole of  $Mg_3(PO_4)_2$  mole of  $Mg_3(PO_4)_2$

$$0.25 \text{ mole of oxygen atom} \equiv \frac{1}{8} \times 0.25 \text{ mole of } Mg_3(PO_4)_2$$

$$= 3.125 \times 10^{-2} \text{ mole of } Mg_3(PO_4)_2$$

12. (a) **TIPS/Formulae :**

$$\text{Apply the formula } d = M \left( \frac{1}{m} + \frac{M_2}{1000} \right)$$

$$\therefore 1.02 = 2.05 \left( \frac{1}{m} + \frac{60}{1000} \right)$$

On solving we get,  $m = 2.288 \text{ mol/kg}$

13. (d) Since molarity of solution is 3.60 M. It means 3.6 moles of  $H_2SO_4$  is present in its 1 litre solution.

$$\text{Mass of 3.6 moles of } H_2SO_4 = \text{Moles} \times \text{Molecular mass} = 3.6 \times 98 \text{ g} = 352.8 \text{ g}$$

$$\therefore 1000 \text{ ml solution has } 352.8 \text{ g of } H_2SO_4$$

$$\text{Given that } 29 \text{ g of } H_2SO_4 \text{ is present in } = 100 \text{ g of solution}$$

$$\therefore 352.8 \text{ g of } H_2SO_4 \text{ is present in}$$

$$= \frac{100}{29} \times 352.8 \text{ g of solution} = 1216 \text{ g of solution}$$

$$\text{Density} = \frac{\text{Mass}}{\text{Volume}} = \frac{1216}{1000} = 1.216 \text{ g/ml} = 1.22 \text{ g/ml}$$

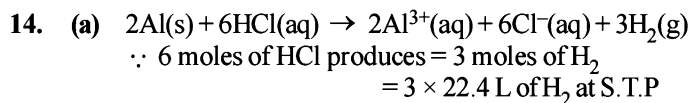

$$\therefore 1 \text{ mole of HCl produces} = \frac{3 \times 22.4}{6} \text{ L of } H_2 \text{ at S.T.P}$$

$$= 11.2 \text{ L of } H_2 \text{ at STP}$$

15. (c) On balancing the given equations we get

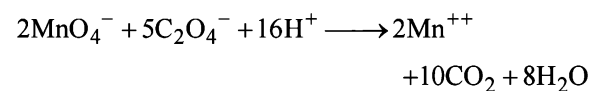

$$\text{So, } x = 2, y = 5 \text{ \& } z = 16$$

16. (d)  $\therefore$  18 g,  $H_2O$  contains = 2 gm H

$$\therefore 0.72 \text{ gm } H_2O \text{ contains} = \frac{2}{18} \times 0.72 \text{ gm} = 0.08 \text{ gm H}$$

$$\therefore 44 \text{ gm } CO_2 \text{ contains} = 12 \text{ gm C}$$

$$\therefore 3.08 \text{ gm } CO_2 \text{ contains} = \frac{12}{44} \times 3.08 = 0.84 \text{ gm C}$$

$$\therefore C : H = \frac{0.84}{12} : \frac{0.08}{1} = 0.07 : 0.08 = 7 : 8$$

$$\therefore \text{Empirical formula} = C_7H_8$$

17. (b) For a one mole of the oxide

$$\text{Moles of } M = 0.98, \text{ Moles of } O^{2-} = 1$$

$$\text{Let moles of } M^{3+} = x$$

$$\text{Moles of } M^{2+} = 0.98 - x$$

on balancing charge

$$(0.98 - x) \times 2 + 3x - 2 = 0 \Rightarrow x = 0.04$$

$$\% \text{ of } M^{3+} = \frac{0.04}{0.98} \times 100 = 4.08\%$$



**Section-A : JEE Advanced/ IIT-JEE**

- A** 1.  $1.66 \times 10^{-27}$  Kg    2. neutrons    3. antiparallel or opposite    4. isobars    5. Heisenberg, de-Broglie  
6. Photons    7. orbitals    8. orientation in space    9.  $3d^5 4s^1$
- B** 1. F    2. F    3. T    4. F    5. T
- C** 1. (d)    2. (c)    3. (d)    4. (a)    5. (a)    6. (d)    7. (a)  
8. (d)    9. (b)    10. (b)    11. (b)    12. (b)    13. (c)    14. (d)  
15. (a)    16. (c)    17. (b)    18. (c)    19. (a)    20. (c)    21. (c)  
22. (d)    23. (c)    24. (b)    25. (a)    26. (a)    27. (a)    28. (b)  
29. (a)    30. (d)    31. (d)    32. (c)    33. (d)    34. (a)    35. (b)  
36. (c)    37. (d)
- D** 1. (b, d)    2. (a, c)    3. (a, c)    4. (b, d)    5. (a)    6. (a, b, c)    7. (a, c, d)  
8. (a, d)
- E** 1. 80%    2.  $6.603 \text{ \AA}$     3.  $1220 \text{ \AA}$     4.  $5.42 \times 10^{-12}$  ergs,  $3.67 \times 10^{-5}$  cm  
6. 10    7.  $2055 \text{ \AA}$     8.  $10.22 \text{ eV}$ ,  $2, \text{He}^+$     9.  $n = 2$  to  $n = 1$     10. 3
11.  $2.165 \times 10^{-20}$     12.  $27419.25 \text{ cm}^{-1}$     13.  $-\frac{e^2}{4\pi\epsilon_0 \cdot a_0}, \frac{-e^2}{8\pi\epsilon_0 a_0}$     14. 98.17 kJ
15. 22.8 nm    16.  $2a_0$     17.  $6.627 \times 10^{-35} \text{ m}$     18.  $3.34 \times 10^{-10} \text{ m}, \sqrt{2} \frac{h}{2\pi}$
- F** 1. (A)-r, (B)-q, (C)-p, (D)-s    2. (A)-q, r; (B)-p, q, r, s; (C)-p, q, r; (D)-p, q
- G** 1. (b)    2. (c)    3. (b)
- H** 1. (c)    2. (b)    3. (a)
- I** 1. 4    2. 9    3. 5    4. 6    5. 3

**Section-B : JEE Main/ AIEEE**

1. (a)    2. (c)    3. (c)    4. (a)    5. (a)    6. (a)    7. (d)  
8. (a)    9. (b)    10. (c)    11. (c)    12. (a)    13. (b)    14. (b)  
15. (a)    16. (c)    17. (c)    18. (b)    19. (d)    20. (a)    21. (b)  
22. (d)    23. (b)    24. (c)    25. (b)    26. (a)    27. (a)    28. (a)    29. (b)

**Section-A JEE Advanced/ IIT-JEE****A. Fill in the Blanks**

1.  $1.66 \times 10^{-27}$  kg  
Mass of hydrogen atom  
$$= \frac{\text{Atomic mass of hydrogen}}{\text{Avogadro number}} = \frac{1.008}{6.02 \times 10^{23}}$$
$$= 0.166 \times 10^{-23} \text{ g} = 1.66 \times 10^{-27} \text{ kg}$$
2. neutrons;  
3. antiparallel; or opposite  
4. isobars;

5. Heisenberg, de-Broglie;  
6. photons  
7. orbitals  
8. orientation in space  
9.  $4s^1, 3d^5$ ;

The electronic configuration of Cr is :  $1s^2, 2s^2, 2p^6, 3s^2, 3p^6, 4s^1, 3d^5$ .

$\therefore$  Outermost electronic configuration is  $3d^5, 4s^1$ .

**B. True/False**

- False** : The outer electronic configuration of the ground state chromium atom is  $3d^5 4s^1$ , as half filled orbitals are more stable than nearly half filled orbitals.
- False** : Gamma rays are electromagnetic radiations of wavelengths  $10^{-9}$  cm to  $10^{-10}$  cm.
- True** : Although energies of the  $s$  and  $p$  orbitals for the same principal quantum number are very close to each other; the energy of the corresponding  $d$  orbitals is much higher. For example, the energy of  $3d$  orbitals is much more than that of  $3s$  and  $3p$ ; orbitals but less than  $4s$  orbitals in case of H atom.
- False** : The orbital  $3d_{x^2-y^2}$  lie along  $X$  and  $Y$  axis where electron density is maximum.
- True** :  $\beta$ -particles are deflected more than  $\alpha$ -particles because they have very-very large  $e/m$  value as compared to  $\alpha$ -particles due to the fact that electrons are much lighter than  $\text{He}^{2+}$  species.

**C. MCQs with One Correct Answer**

- (d)** No. of neutrons = Mass number – Atomic number  
=  $70 - 30 = 40$ .
- (c)** Rutherford's scattering experiment led to the discovery of nucleus.
- (d)** One  $p$ -orbital can accommodate up to two electrons with opposite spin while  $p$ -subshell can accommodate upto six electrons.
- (a)** The principal quantum number ( $n$ ) is related to the size of the orbital ( $n = 1, 2, 3, \dots$ )
- (a)** According to Rutherford's experiment. "The central part consisting of whole of the positive charge and most of the mass, called nucleus, is extremely small in size compared to the size of the atom."
- (d)**  $\frac{e}{m}$  for neutron =  $\frac{0}{1} = 0$ ;  $\alpha$ -particle =  $\frac{2}{4} = 0.5$ ;  
proton =  $\frac{1}{1} = 1$ ; electron =  $\frac{1}{1/1837} = 1837$
- (a)** Rb has the configuration :  $1s^2 2s^2 p^6 3s^2 p^6 d^{10} 4s^2 p^6 5s^1$ , so  $n = 5, l = 0, m = 0$  and  $s = +\frac{1}{2}$  is correct set of quantum numbers for valence shell electron of Rb.
- (d)** **NOTE** : Energy is emitted when electron falls from higher energy level to lower energy level and energy is absorbed when electron moves from lower level to higher level.  
 $1s$  is the lowest energy level of electron in an atom.  
 $\therefore$  An electron in  $1s$  level of hydrogen can absorb energy but cannot emit energy.
- (b)** Bohr model can explain spectrum of atoms/ions containing one electron only.
- (b)** The radius of nucleus is of the order of  $1.5 \times 10^{-13}$  to  $6.5 \times 10^{-13}$  cm or 1.5 to 6.5 Fermi (1 Fermi =  $10^{-13}$  cm)
- (b)** **TIPS/Formulæ** : The following is the increasing order of wavelength or decreasing order of energy of electromagnetic radiations :  
  
cosmic rays  
 $\gamma$ -rays  
X-rays  
UV-rays  
Visible  
Infra-red radiation  
Micro waves  
Radio waves  
  
Increasing  $\lambda$   
Decreasing  $\nu$   
  
Among given choices radiowaves have maximum wavelength.
- (b)** Electrons in an atom occupy the extra nuclear region.
- (c)** If  $l = 2, m \neq -3, m$  will vary from  $-2$  to  $+2$ . i.e. possible values of  $m$  are  $-2, -1, 0, +1$  and  $+2$ .
- (d)**  $E = \frac{hc}{\lambda}$ ;  $\lambda_1 = 2000 \text{ \AA}$ ;  $\lambda_2 = 4000 \text{ \AA}$ ;  
  
so  $\frac{E_1}{E_2} = \frac{\lambda_2}{\lambda_1} = \frac{4000}{2000} = 2$
- (a)** Isotones have same number of neutrons. All atoms in triad (a) have same number of neutrons ( $= A - Z = 8$ ).
- (c)** Difference in the energy of the energy levels involved in the transition.
- (b)** According to Aufbau principle, the orbital of lower energy ( $2s$ ) should be fully filled before the filling of orbital of higher energy starts.
- (c)** **TIPS/Formulæ** : The element having highest tendency to accept the electron will be most electronegative element.  
Configuration  $ns^2, np^5$  means it requires only one electron to attain nearest noble gas configuration. So, it will be most electronegative element among given choices.
- (a)** **NOTE** : Exactly half filled orbitals are more stable than nearly half filled orbitals.  
Cr (At. no. 24) has configuration  $[\text{Ar}] 3d^5, 4s^1$ .
- (c)** Electronic configuration of chlorine is  $[\text{Ne}] 3s^2, 3p^5$   
 $\therefore$  Unpaired electron is found in  $3p$  sub-shell.  
 $\therefore n = 3, l = 1, m = 1$
- (c)** **X-rays** can ionise gases and cannot get deflected by electric and magnetic fields, wavelength of these rays is  $150$  to  $0.1 \text{ \AA}$ . Thus the wavelength of  $X$ -rays is shorter than that of u.v. rays.
- (d)** As packet of energy equal to  $h\nu$ ; as wave having frequency  $\nu$ .

23. (c) **TIPS/Formulae** : Total nodes =  $n - l$   
 No. of radial nodes =  $n - l - 1$   
 No. of angular nodes =  $l$   
 For  $3p$  sub-shell,  $n = 3, l = 1$   
 $\therefore$  No. of radial nodes =  $n - l - 1 = 3 - 1 - 1 = 1$   
 $\therefore$  No. of angular nodes =  $l = 1$

24. (b) **TIPS/Formulae** :

$$\text{Orbital angular momentum (mvr)} = \frac{h}{2\pi} \sqrt{l(l+1)}$$

For  $2s$  orbital,  $l$  (azimuthal quantum number) = 0

$\therefore$  Orbital angular momentum = 0.

25. (a) The expression for orbital angular momentum is

$$\text{Angular momentum} = \sqrt{l(l+1)} \left( \frac{h}{2\pi} \right)$$

For  $d$  orbital,  $l = 2$ .

$$\text{Hence, } L = \sqrt{2(2+1)} \left( \frac{h}{2\pi} \right) = \sqrt{6} \left( \frac{h}{2\pi} \right)$$

26. (a) **TIPS/Formulae** : The two guiding rules to arrange the various orbitals in the increasing energy are:

(i) Energy of an orbital increases with increase in the value of  $n + l$ .

(ii) Of orbitals having the same value of  $n + l$ , the orbital with lower value of  $n$  has lower energy.

Thus for the given orbitals, we have

$$(i) \ n + l = 4 + 1 = 5 \quad (ii) \ n + l = 4 + 0 = 4$$

$$(iii) \ n + l = 3 + 2 = 5 \quad (iv) \ n + l = 3 + 1 = 4$$

Hence, the order of increasing energy is

$$(iv) < (ii) < (iii) < (i)$$

27. (a)  $p_x$  orbital being dumbbell shaped, have number of nodal planes = 1, in  $yz$  plane.

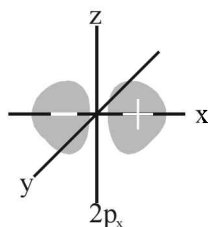

28. (b)  $3d^5 4s^1$  system is more stable than  $3d^4 4s^2$ , hence former is the ground state configuration.

29. (a) **TIPS/Formulae** : According to de-Broglie's equation

$$\lambda = \frac{h}{p} = \frac{h}{mv}$$

Given,  $h = 6.6 \times 10^{-34}$  Js,  $m = 200 \times 10^{-3}$  kg

$$v = \frac{5}{60 \times 60} \text{ m/s}$$

$$\lambda = \frac{6.6 \times 10^{-34}}{200 \times 10^{-3} \times 5 / (60 \times 60)} = 2.38 \times 10^{-10} \text{ m}$$

30. (d) The term spin implies that this magnetic moment is produced by the electron charge as the electron rotates about its own axis. Although this conveys a vivid mental picture of the source of the magnetism, the electron is not an extended body and its rotation is meaningless. Electron spin has no classical counterpart; the magnetic moment is a consequence of relativistic shifts in local space and time due to the high effective velocity of the electron in the atom.

31. (d) Rutherford's experiment was actually  $\alpha$ -particle scattering experiment.  $\alpha$ -Particle is doubly positively charged helium ion i.e., He - nucleus.

32. (c) As per Pauli Exclusion Principle "no two electrons in the same atom can have all the four quantum numbers equal or an orbital cannot contain more than two electrons and it can accommodate two electrons only when their directions of spins are opposite".

33. (d) **TIPS/Formulae** :  $r_n = 0.529 \frac{n^2}{Z} \text{ \AA}$

For hydrogen,  $n = 1$  and  $Z = 1$ ;  $\therefore r_H = 0.529$

For  $\text{Be}^{3+}$ ,  $n = 2$  and  $Z = 4$ ;

$$\therefore r_{\text{Be}^{3+}} = \frac{0.529 \times 2^2}{4} = 0.529$$

34. (a) **TIPS/Formulae** :

Number of radial nodes =  $(n - l - 1)$

For  $3s$ :  $n = 3, l = 0$  (Number of radial node = 2)

For  $2p$ :  $n = 2, l = 1$  (Number of radial node = 0)

35. (b) Average atomic mass of Fe

$$= \frac{(54 \times 5) + (56 \times 90) + (57 \times 5)}{100} = 55.95$$

36. (c) As per Bohr's postulate,

$$mvr = \frac{nh}{2\pi} \quad \text{So, } v = \frac{nh}{2\pi mr}$$

$$\text{KE} = \frac{1}{2} mv^2 \quad \text{So, } \text{KE} = \frac{1}{2} m \left( \frac{nh}{2\pi mr} \right)^2$$

$$\text{Since, } r = \frac{a_0 \times n^2}{z}$$

So, for 2<sup>nd</sup> Bohr orbit

$$r = \frac{a_0 \times 2^2}{1} = 4a_0$$

$$\text{KE} = \frac{1}{2} m \left( \frac{2^2 h^2}{4\pi^2 m^2 \times (4a_0)^2} \right) = \frac{h^2}{32\pi^2 m a_0^2}$$

37. (d) Radial probability function curve for  $1s$  is (D). Here P is  $4\pi r^2 R^2$ .

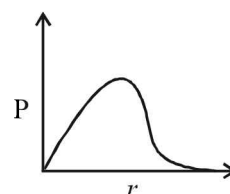

**D. MCQs with One or More Than One Correct**

- (b,d)  ${}^{77}_{33}\text{As}$  and  ${}^{78}_{34}\text{Se}$  have same number of neutrons  
( $=A-Z$ ) as  ${}^{76}_{32}\text{Ge}$ .
- (a,c) Because they have isotopes with different masses. The average atomic mass is the weighed mean of their presence in nature; eg.  $\text{Cl}^{35}$  and  $\text{Cl}^{37}$  are present in ratio 3 : 1 in nature.  
So  $A = \frac{35 \times 3 + 37 \times 1}{4} = 35.5$
- (a,c)  $\alpha$ -particles pass through because most part of the atom is empty.
- (b,d) In tritium (the isotope of hydrogen) nucleus there is one proton and 2 neutrons.  $\therefore n+p=3$ . In deuterium nucleus there is one proton and one neutron  $\therefore n+p=2$ .
- (a,d) The energy of an electron on Bohr orbits of hydrogen atoms is given by the expression  
$$E_n = -\frac{\text{Constant}}{n^2}$$
Where  $n$  takes only integral values. For the first Bohr orbit,  $n=1$  and it is given that  $E_1 = -13.6 \text{ eV}$   
Hence  $E_n = -\frac{13.6\text{eV}}{n^2}$  of the given values of energy, only  $-3.4 \text{ eV}$  and  $-1.5 \text{ eV}$  can be obtained by substituting  $n=2$  and  $3$  respectively in the above expression.
- (a,b,c) (a)  ${}_{24}\text{Cr} = 1s^2, 2s^2 2p^6, 3s^2 3p^6 3d^5, 4s^1 = [\text{Ar}] 3d^5, 4s^1$   
(b) For magnetic quantum number ( $m$ ), negative values are possible.  
For  $s$ -subshell,  $l=0$ , hence  $m=0$   
for  $p$ -subshell,  $l=1$ , hence  $m=-1, 0, +1$   
(c)  ${}_{47}\text{Ag} = 1s^2, 2s^2 2p^6, 3s^2 3p^6 3d^{10}, 4s^2 4p^6 4d^{10}, 5s^1$   
Hence 23 electrons have a spin of one type and 24 of the opposite type.  
(d) Oxidation state of N in  $\text{HN}_3$  is  $-1/3$ .
- (a,c,d) (a)  ${}_z X^A \xrightarrow{-\alpha} {}_{z-2} Y^{A-4}$  ( $\alpha$ -emission);  
(b)  ${}_z X^A \xrightarrow{-\beta} {}_{z+1} Z^A$  ( $\beta$ -emission);  
(c)  ${}_z X^A \xrightarrow{+1e^0} {}_{z-1} D^A$  (positron-emission);  
(d)  ${}_z X^A + {}_{-1}e^0 \rightarrow {}_{z-1} D^A$  (electron-capture)  
Atomic number increases during  $\beta$ -emission
- (a,d) According to Hund's rule pairing of electrons starts only when each of the orbital in a sub shell has one electron each of parallel spin.  
 $\therefore$  (a) and (d) are correct ground state electronic configurations of nitrogen atom in ground state.

**E. Subjective Problems**

- Let the % of isotope with At. wt. 10.01 =  $x$   
 $\therefore$  % of isotope with At. wt. 11.01 =  $(100-x)$   
At. wt. of boron =  $\frac{x \times 10.01 + (100-x) \times 11.01}{100}$   
 $\Rightarrow 10.81 = \frac{x \times 10.01 + (100-x) \times 11.01}{100} \therefore x=20$   
Hence % of isotope with At. wt. 10.01 = 20%  
 $\therefore$  % of isotope with At. wt. 11.01 =  $100-20 = 80\%$ .
- TIPS/Formulae** :  $\Delta E = E_3 - E_2 = h\nu = \frac{hc}{\lambda}$  or  
$$\lambda = \frac{hc}{E_3 - E_2}$$
Given  $E_2 = -5.42 \times 10^{-12} \text{ erg}$ ,  $E_3 = -2.41 \times 10^{-12} \text{ erg}$   
$$\therefore \lambda = \frac{6.626 \times 10^{-27} \times 3 \times 10^{10}}{-2.41 \times 10^{-12} - (-5.42 \times 10^{-12})}$$
$$= \frac{19.878 \times 10^{-17}}{3.01 \times 10^{-12}} = 6.604 \times 10^{-5} \text{ cm} = 6.604 \text{ \AA}$$
- TIPS/Formulae** : (i) Energy of  $n^{\text{th}}$  orbit =  $E_n = \frac{E_1}{n^2}$   
(ii) Difference in energy =  $E_1 - E_2 = h\nu = \frac{hc}{\lambda}$   
or  $\lambda = \frac{hc}{E_1 - E_2}$   
Given  $E_1 = 2.17 \times 10^{-11}$   
$$\therefore \text{Energy of second orbit} = E_2 = \frac{2.17 \times 10^{-11}}{2^2}$$
$$= 0.5425 \times 10^{-11} \text{ erg}$$
$$\Delta E = E_1 - E_2 = 2.17 \times 10^{-11} - 0.5425 \times 10^{-11}$$
$$= 1.6275 \times 10^{-11} \text{ erg}$$
$$\lambda = \frac{6.62 \times 10^{-27} \times 3 \times 10^{10}}{1.6275 \times 10^{-11}} = 12.20 \times 10^{-6} \text{ cm} = 1220 \text{ \AA}$$
- TIPS/Formulae** : To calculate the energy required to remove electron from atom,  $n = \infty$  is to be taken.  
Energy of an electron in the  $n^{\text{th}}$  orbit of hydrogen is given by  
$$E = -21.7 \times 10^{-12} \times \frac{1}{n^2} \text{ ergs}$$
$$\therefore \Delta E = -21.7 \times 10^{-12} \left( \frac{1}{2^2} - \frac{1}{\infty^2} \right)$$
$$= -21.7 \times 10^{-12} \left( \frac{1}{4} - 0 \right) = -21.7 \times 10^{-12} \times \frac{1}{4}$$
$$= -5.42 \times 10^{-12} \text{ ergs}$$

Now we know that  $\Delta E = hv$

$$\therefore \Delta E = \frac{hc}{\lambda} \left( \because v = \frac{c}{\lambda} \right) \quad \text{or} \quad \lambda = \frac{hc}{\Delta E}$$

$$\text{Substituting the values, } \lambda = \frac{6.627 \times 10^{-27} \times 3 \times 10^{10}}{5.42 \times 10^{-12}}$$

$$= 3.67 \times 10^{-5} \text{ cm}$$

5. Ground state electronic configuration of Si



is in accordance with Hund's rule which states that electron pairing in any orbital (*s*, *p*, *d* or *f*) cannot take place until each orbital of the same sub-level contains 1 electron each of like spin.

6. For  $n = 3$  and  $l = 2$  (i.e.,  $3d$  orbital), the values of  $m$  varies from  $-2$  to  $+2$ , i.e.  $-2, -1, 0, +1, +2$  and for each ' $m$ ' there are 2 values of ' $s$ ', i.e.  $+\frac{1}{2}$  and  $-\frac{1}{2}$ .

$\therefore$  Maximum no. of electrons in all the five  $d$ -orbitals is **10**.

7.  $E_n$  of H =  $\frac{-21.76 \times 10^{-19}}{n^2}$  J

$$\therefore E_n \text{ of He}^+ = \frac{-21.76 \times 10^{-19}}{n^2} \times Z^2 \text{ J}$$

$$\therefore E_3 \text{ of He}^+ = \frac{-21.76 \times 10^{-19} \times 4}{9} \text{ J}$$

Hence energy equivalent to  $E_3$  must be supplied to remove the electron from  $3^{\text{rd}}$  orbit of  $\text{He}^+$ . Wavelength corresponding to this energy can be determined by applying the relation.

$$E = \frac{hc}{\lambda} \quad \text{or} \quad \lambda = \frac{hc}{E} = \frac{6.625 \times 10^{-34} \times 3 \times 10^8 \times 9}{21.76 \times 10^{-19} \times 4}$$

$$= 2055 \times 10^{-10} \text{ m} = \mathbf{2055 \text{ \AA}}$$

8. **TIPS/Formulae :**  $\Delta E = RhcZ^2 \left( \frac{1}{n_1^2} - \frac{1}{n_2^2} \right)$

Here,  $R = 1.0967 \times 10^7 \text{ m}^{-1}$

$h = 6.626 \times 10^{-34} \text{ J sec}$ ,  $c = 3 \times 10^8 \text{ m/sec}$

$n_1 = 1$ ,  $n_2 = 2$  and for H-atom,  $Z = 1$

$$E_2 - E_1 = 1.0967 \times 10^7 \times 6.626 \times 10^{-34} \times 3 \times 10^8 \left( \frac{1}{1} - \frac{1}{4} \right)$$

$$\Delta E = 1.0967 \times 6.626 \times 3 \times \frac{3}{4} \times 10^{-19} \text{ J}$$

$$= 16.3512 \times 10^{-19} \text{ J}$$

$$= \frac{16.3512 \times 10^{-19}}{1.6 \times 10^{-19}} \text{ eV} = \mathbf{10.22 \text{ eV}}$$

$$\Delta E = \frac{hc}{\lambda} = RhcZ^2 \left( \frac{1}{n_1^2} - \frac{1}{n_2^2} \right)$$

$$\frac{1}{\lambda} = RZ^2 \left( \frac{1}{1} - \frac{1}{4} \right) = RZ^2 \times \frac{3}{4}$$

Given,  $\lambda = 3 \times 10^{-8} \text{ m}$

$$\therefore \frac{1}{3 \times 10^{-8}} = 1.0967 \times Z^2 \times \frac{3}{4} \times 10^7$$

$$\therefore Z^2 = \frac{10^8 \times 4}{3 \times 3 \times 1.0967 \times 10^7} = \frac{40}{9 \times 1.0967} \approx 4 \quad \therefore Z = 2$$

So it corresponds to  $\text{He}^+$  which has 1 electron like hydrogen.

9. For  $\text{He}^+$  ion, we have

$$\begin{aligned} \frac{1}{\lambda} &= Z^2 R_H \left[ \frac{1}{n_1^2} - \frac{1}{n_2^2} \right] \\ &= (2)^2 R_H \left[ \frac{1}{(2)^2} - \frac{1}{(4)^2} \right] = R_H \frac{3}{4} \quad \dots (i) \end{aligned}$$

$$\text{Now for hydrogen atom } \frac{1}{\lambda} = R_H \left[ \frac{1}{n_1^2} - \frac{1}{n_2^2} \right] \quad \dots (ii)$$

Equating equations (i) and (ii), we get

$$\frac{1}{n_1^2} - \frac{1}{n_2^2} = \frac{3}{4}$$

Obviously,  $n_1 = 1$  and  $n_2 = 2$

Hence, the transition  $n = 2$  to  $n = 1$  in hydrogen atom will have the same wavelength as the transition,  $n = 4$  to  $n = 2$  in  $\text{He}^+$  species.

10. **TIPS/Formulae :** Number of waves =  $\frac{n(n-1)}{2}$

where  $n$  = Principal quantum number or number of orbit

$$\text{Number of waves} = \frac{3(3-1)}{2} = \frac{3 \times 2}{2} = 3$$

11. Bond energy of  $\text{I}_2 = 240 \text{ kJ mol}^{-1} = 240 \times 10^3 \text{ J mol}^{-1}$

$$= \frac{240 \times 10^3}{6.023 \times 10^{23}} \text{ J molecule}^{-1}$$

$$= 3.984 \times 10^{-19} \text{ J molecule}^{-1}$$

$$\text{Energy absorbed} = \frac{hc}{\lambda} = \frac{6.626 \times 10^{-34} \text{ Js} \times 3 \times 10^8 \text{ ms}^{-1}}{4500 \times 10^{-10} \text{ m}}$$

$$= 4.417 \times 10^{-19} \text{ J}$$

Kinetic energy = Absorbed energy – Bond energy

$$\therefore \text{Kinetic energy} = 4.417 \times 10^{-19} - 3.984 \times 10^{-19} \text{ J} \\ = 4.33 \times 10^{-20} \text{ J}$$

$\therefore$  Kinetic energy of each atom of iodine

$$= \frac{4.33 \times 10^{-20}}{2} = 2.165 \times 10^{-20}$$

12. The shortest wavelength transition in the Balmer series corresponds to the transition

$n=2 \rightarrow n=\infty$ . Hence,  $n_1=2, n_2=\infty$  Balmer

$$\bar{\nu} = R_H \left( \frac{1}{n_1^2} - \frac{1}{n_2^2} \right) = (109677 \text{ cm}^{-1}) \left( \frac{1}{2^2} - \frac{1}{\infty^2} \right) \\ = 27419.25 \text{ cm}^{-1}$$

13. Work done while bringing an electron infinitely slowly from infinity to proton of radius  $a_0$  is given as follows

$$W = -\frac{e^2}{4\pi\epsilon_0 \cdot a_0}$$

**NOTE :** This work done is equal to the total energy of an electron in its ground state in the hydrogen atom. At this stage, the electron is not moving and do not possess any K.E., so this total energy is equal to the potential energy.

$$\text{T.E.} = \text{P.E.} + \text{K.E.} = \text{P.E.} = -\frac{e^2}{4\pi\epsilon_0 \cdot a_0} \quad \dots(1)$$

In order the electron to be captured by proton to form a ground state hydrogen atom it should also attain

$$\text{K.E.} = \frac{e^2}{8\pi\epsilon_0 a_0}$$

(It is given that magnitude of K.E. is half the magnitude of P.E. Note that P.E. is -ve and K.E. is +ve)

$$\therefore \text{T.E.} = \text{P.E.} + \text{K.E.} = -\frac{e^2}{4\pi\epsilon_0 a_0} + \frac{e^2}{8\pi\epsilon_0 a_0}$$

$$\text{or T.E.} = -\frac{e^2}{8\pi\epsilon_0 a_0}$$

$$\text{P.E.} = 2 \times \text{T.E.} = 2 \times \frac{-e^2}{8\pi\epsilon_0 a_0} \text{ or } \text{P.E.} = \frac{-e^2}{4\pi\epsilon_0 a_0}$$

14. Determination of number of moles of hydrogen gas,

$$n = \frac{PV}{RT} = \frac{1 \times 1}{0.082 \times 298} = 0.0409$$

The concerned reaction is  $\text{H}_2 \longrightarrow 2\text{H}$ ;  $\Delta H = 436 \text{ kJ mol}^{-1}$

Energy required to bring 0.0409 moles of hydrogen gas to atomic state =  $436 \times 0.0409 = 17.83 \text{ kJ}$

Calculation of total number of hydrogen atoms in 0.0409 mole of  $\text{H}_2$  gas

1 mole of  $\text{H}_2$  gas has  $6.02 \times 10^{23}$  molecules

$$0.0409 \text{ mole of } \text{H}_2 \text{ gas} = \frac{6.02 \times 10^{23}}{1} \times 0.0409 \text{ molecules}$$

Since 1 molecule of  $\text{H}_2$  gas has 2 hydrogen atoms

$$6.02 \times 10^{23} \times 0.0409 \text{ molecules of } \text{H}_2 \text{ gas} \\ = 2 \times 6.02 \times 10^{23} \times 0.0409 = 4.92 \times 10^{22} \text{ atoms of hydrogen}$$

Since energy required to excite an electron from the ground state to the next excited state is given by

$$E = 13.6 \left( \frac{1}{n_1^2} - \frac{1}{n_2^2} \right) \text{ eV} = 13.6 \times \left( \frac{1}{1} - \frac{1}{4} \right) = 13.6 \times \frac{3}{4} = 10.2 \text{ eV}$$

$$= 1.632 \times 10^{-21} \text{ kJ}$$

Therefore energy required to excite  $4.92 \times 10^{22}$  electrons =  $1.632 \times 10^{-21} \times 4.92 \times 10^{22} \text{ kJ} = 8.03 \times 10 = 80.3 \text{ kJ}$

Therefore total energy required =  $17.83 + 80.3 = 98.17 \text{ kJ}$

15. For maximum energy,  $n_1 = 1$  and  $n_2 = \infty$

$$\frac{1}{\lambda} = R_H Z^2 \left( \frac{1}{n_1^2} - \frac{1}{n_2^2} \right)$$

Since  $R_H$  is a constant and transition remains the same

$$\frac{1}{\lambda} \propto Z^2 ; \frac{\lambda_{\text{He}}}{\lambda_{\text{H}}} = \frac{Z_{\text{H}}^2}{Z_{\text{He}}^2} = \frac{1}{4}$$

$$\text{Hence, } \lambda_{\text{He}} = \frac{1}{4} \times 91.2 = 22.8 \text{ nm}$$

16.  $\psi_{2s}^2$  = probability of finding electron within 2s sphere

$$\psi_{2s}^2 = 0 \text{ (at node)}$$

( $\therefore$  probability of finding an electron is zero at node)

$$\therefore 0 = \frac{1}{32\pi} \left( \frac{1}{a_0} \right)^3 \left( 2 - \frac{r_0}{a_0} \right)^2 \cdot e^{-\frac{2r_0}{a_0}}$$

(Squaring the given value of  $\psi_{2s}$ )

$$\text{or } \left[ 2 - \frac{r_0}{a_0} \right] = 0 ; \therefore 2 = \frac{r_0}{a_0} ; 2a_0 = r_0$$

$$17. \lambda = \frac{h}{mu} = \frac{6.627 \times 10^{-34}}{0.1 \times 100}$$

$$\text{or } \lambda = 6.627 \times 10^{-35} \text{ m} = 6.627 \times 10^{-25} \text{ \AA}$$

18. For hydrogen atom,  $Z = 1, n = 1$

$$v = 2.18 \times 10^6 \times \frac{Z}{n} \text{ ms}^{-1} = 2.18 \times 10^6 \text{ ms}^{-1}$$

de Broglie wavelength,

$$\lambda = \frac{h}{mv} = \frac{6.626 \times 10^{-34}}{9.1 \times 10^{-31} \times 2.18 \times 10^6} \\ = 3.34 \times 10^{-10} \text{ m} = 3.3 \text{ \AA}$$

For  $2p, l = 1$

$$\therefore \text{Orbital angular momentum} = \sqrt{l(l+1)} \frac{h}{2\pi} = \sqrt{2} \frac{h}{2\pi}$$

## F. Match the Following

1. (A) - (r); (B) - (q); (C) - (p); (D) - (s)

$$(i) \frac{V_n}{K_n} = \frac{-Kze^2/r}{Kze^2/2r} = -2; \text{ where } K = \frac{i}{4\pi\epsilon_0} \therefore (i)-(c)$$

$$(ii) r_n \propto (E_n)^{-1}; \therefore (ii)-(b)$$

$$(iii) \text{Angular momentum of electron in lowest (1s) orbital} \\ = \sqrt{\ell(\ell+1)} \frac{h}{2\pi} = \sqrt{0(0+1)} \frac{h}{2\pi} = 0; \therefore (iii)-(a)$$

$$(iv) \frac{1}{r^n} \propto Z^1; \therefore (iv)-(d)$$

2. A-q,r; B-p,q,r,s; C-p, q, r; D-p, q

## G. Comprehension Based Questions

**For 1-3** The spherically symmetric state  $S_1$  of  $Li^{2+}$  with one radial node is  $2s$ . Upon absorbing light, the ion gets excited to state  $S_2$ , which also has one radial node. The energy of electron in  $S_2$  is same as that of  $H$ -atom in its ground state.

$$\therefore E_n = \frac{Z^2}{n^2} E_1 \text{ where } E_1 \text{ is the energy of H-atom in the}$$

$$\text{ground state} = \frac{(3)^2 E_1}{n^2} \text{ for } Li^{2+}$$

$$E_n = E_1 \Rightarrow n = 3$$

$\therefore$  State  $S_2$  of  $Li^{2+}$  having one radial node is  $3p$ .  
Orbital angular momentum quantum number of  $3p$  is 1.

$$\text{Energy of state } S_1 = \frac{(3)^2}{(2)^2} E_1 = 2.25 E_1$$

1. (b)                      2. (c)                      3. (b)

## H. Assertion &amp; Reason Type Questions

1. (c) Nuclides having both even number of protons and neutrons have maximum stability. So the reason is incorrect. But the assertion is correct as  $^{40}\text{Ca}_{20}$  has even number of neutrons and protons as compared to  $^{30}\text{Al}_{13}$ , which has odd neutrons and protons.
2. (b) Statement-1 is correct because as we go down a group, energy gap between successive orbits decreases which causes decrease in the energy gap between valence band and conduction band. Statement-2 is also correct because each band is a collection of closely spaced large number of atomic energy levels. But this is not true correct explanation of statement-1.

3. (a)

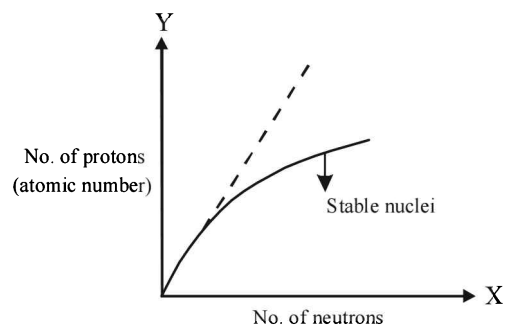

A look at the above curve shows that for stable nuclei it shows a curvature towards x-axis from the line of 45° slope (dotted line) as the atomic number (i.e. number of protons) increases. So statement 1 is true.

The proton - proton repulsion would overcome the attractive force of proton and neutron. Thus statement 2 in True. Also this statement 2 is a correct explanation for statement 1. Therefore the correct answer is option (a).

## I. Integer Value Correct Type

1. 4

$$\text{Energy associated with incident photon} = \frac{hc}{\lambda}$$

$$E = \frac{6.6 \times 10^{-34} \times 3 \times 10^8}{300 \times 10^{-9}} \text{ J}$$

$$= \frac{6.6 \times 10^{-34} \times 3 \times 10^8}{300 \times 10^{-9} \times 1.6 \times 10^{-19}} \text{ eV} = 4.16 \text{ eV}$$

Photoelectric effect can take place only when  $E_{\text{photon}} > \phi$

Thus, number of metals showing photoelectric effect will be 4 (i.e. Li, Na, K and Mg).

2. 9

Maximum number of electrons ( $n^2$ ) when  $n = 3 = 3^2 = 9$   
 $\therefore$  Number of orbitals = 9

$\therefore$  Number of electrons with  $m_s = -\frac{1}{2}$  will be 9.

3. (5) Since,

$$\lambda = \frac{h}{mV} = \frac{h}{\sqrt{2MK.E}} \text{ (since K.E.} \propto T)$$

$$\Rightarrow \lambda \propto \frac{1}{\sqrt{MT}}$$

For two gases,

$$\frac{\lambda_{\text{He}}}{\lambda_{\text{Ne}}} = \sqrt{\frac{M_{\text{Ne}} T_{\text{Ne}}}{M_{\text{He}} T_{\text{He}}}} = \sqrt{\frac{20 \times 1000}{4 \times 200}} = 5$$

4. (6)  $|m_l| = 1$  means  $m_l$  can be +1 and -1.

So, for  $n = 4$ , six orbitals are possible and each has 1 electron with  $s = -\frac{1}{2}$ . So total number of electrons = 6.

5. (3) Ground state configuration:

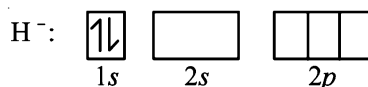

in second excited state, electron will jump from 1s to 2p, so degeneracy of second excited state of  $\text{H}^-$  is 3.

## Section-B

## JEE Main/AIEEE

1. (a) 2<sup>nd</sup> excited state will be the 3<sup>rd</sup> energy level.

$$E_n = \frac{13.6}{n^2} \text{ eV} \quad \text{or} \quad E = \frac{13.6}{9} \text{ eV} = 1.51 \text{ eV.}$$

2. (c) TIPS/Formulae :

$$\Delta x \cdot \Delta p = \frac{h}{4\pi}; \quad \text{or} \quad \Delta x \cdot m \cdot \Delta v = \frac{h}{4\pi}$$

$$\therefore \Delta v = \frac{6.62 \times 10^{-34}}{4 \times 3.14 \times 0.025 \times 10^{-5}} = 2.1 \times 10^{-28} \text{ ms}^{-1}$$

3. (c)  $\text{Fe}^{++} (26 - 2 = 24) = 1s^2 2s^2 2p^6 3s^2 3p^6 4s^0 3d^6$  hence no. of d electrons retained is 6.

[Two 4s electron are removed]

4. (a) TIPS/Formulae :

For s-electron,  $\ell = 0$

$$\therefore \text{Orbital angular momentum} = \sqrt{0(0+1)} \frac{h}{2\pi} = 0$$

5. (a)  $\text{N}^{3-}$ ,  $\text{F}^-$  and  $\text{Na}^+$  contain 10 electrons each.

6. (a) The lines falling in the visible region comprise Balmer series. Hence the third line from red would be  $n_1 = 2$ ,  $n_2 = 5$  i.e.  $5 \rightarrow 2$ .

7. (d)  $\lambda = \frac{h}{mv} = \frac{6.6 \times 10^{-34}}{60 \times 10^{-3} \times 10} = 10^{-33} \text{ m}$

8. (a) The possible quantum numbers for 4f electron are

$$n = 4, \ell = 3, m = -3, -2, -1, 0, 1, 2, 3 \text{ and } s = \pm \frac{1}{2}$$

Of various possibilities only option (a) is possible.

9. (b) Electronic configuration of Cr atom ( $z = 24$ )

$$= 1s^2, 2s^2 2p^6, 3s^2 3p^6 3d^5, 4s^1$$

when  $\ell = 1$ , p - subshell,

Numbers of electrons = 12

when  $\ell = 2$ , d - subshell,

Numbers of electrons = 5

10. (c) TIPS/Formulae :

$$\frac{1}{\lambda} = R \left( \frac{1}{n_1^2} - \frac{1}{n_2^2} \right)$$

$$\frac{1}{\lambda} = 1.097 \times 10^7 \left( \frac{1}{1} - \frac{1}{\infty} \right) = 1.097 \times 10^7$$

$$\lambda = 91.15 \times 10^{-9} \text{ m} \approx 91 \text{ nm}$$

11. (c)  ${}_{19}\text{K}^+$ ,  ${}_{20}\text{Ca}^{2+}$ ,  ${}_{21}\text{Sc}^{3+}$ ,  ${}_{17}\text{Cl}^-$

each contains 18 electrons.

12. (a) The energy of an orbital is given by  $(n + \ell)$  in (d) and (c).  $(n + \ell)$  value is  $(3 + 2) = 5$  hence they will have same energy, since their n values are also same.

13. (b) Calculating number of electrons

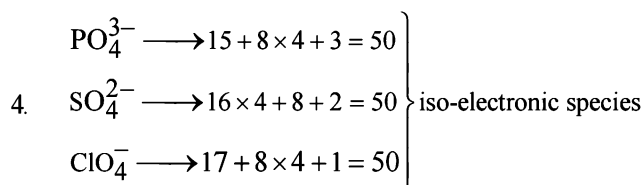
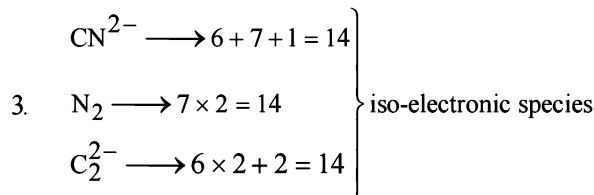
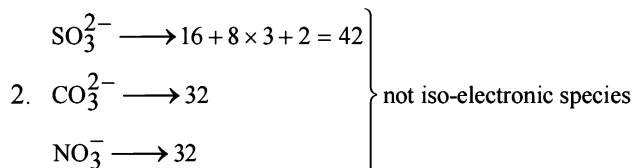
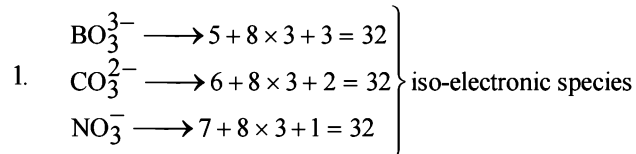

Hence the species in option (b) are not isoelectronic.

14. (b) Angular momentum of an electron in nth orbital is given by,

$$mvr = \frac{nh}{2\pi}$$

For  $n = 5$ , we have

$$\text{Angular momentum of electron} = \frac{5h}{2\pi} = \frac{2.5h}{\pi}$$

15. (a) Given  $m = 9.1 \times 10^{-31} \text{ kg}$ ,  $h = 6.6 \times 10^{-34} \text{ Js}$

$$\Delta v = \frac{300 \times .001}{100} = 0.003 \text{ ms}^{-1}$$

From Heisenberg's uncertainty principle

$$\Delta x = \frac{6.62 \times 10^{-34}}{4 \times 3.14 \times 0.003 \times 9.1 \times 10^{-31}} = 1.92 \times 10^{-2} \text{ m}$$

16. (c) (a)  $\text{N}^{3-} = 7 + 3 = 10e^-$ ,  $\text{O}^- \longrightarrow 8 + 2 = 10e^-$   
 $\text{F}^- = 9 + 1 = 10e^-$ ,  $\text{S}^{--} \longrightarrow 16 + 2 = 18e^-$

(not iso electronic)

(b)  $\text{Li}^+ = 3 - 1 = 4e^-$ ,  $\text{Na}^+ = 11 - 1 = 10e^-$ ,

$$\text{Mg}^{++} = 12 - 2 = 10e^-$$

$$\text{Ca}^{++} = 20 - 2 = 18e^- \quad (\text{not isoelectronic})$$

(c)  $\text{K}^+ = 19 - 1 = 18e^-$ ,  $\text{Cl}^- = 17 + 1 = 18e^-$ ,

$$\text{Ca}^{++} = 20 - 2 = 18e^-, \text{Sc}^{3+} = 21 - 3 = 18e^-$$

(isoelectronic)

(d)  $\text{Ba}^{++} 56 - 2 = 54e^-$ ,  $\text{Sr}^{++} 38 - 2 = 36e^-$

$$\text{K}^+ = 9 - 1 = 18e^-, \text{Ca}^{++} = 20 - 2 = 18e^-$$

(not isoelectronic)



17. (c) (a)  $n = 3, \ell = 0$  means 3s-orbital and  $n + 1 = 3$   
 (b)  $n = 3, \ell = 1$  means 3p-orbital  $n + 1 = 4$   
 (c)  $n = 3, \ell = 2$  means 3d-orbital  $n + 1 = 5$   
 (d)  $n = 4, \ell = 0$  means 4s-orbital  $n + 1 = 4$

Increasing order of energy among these orbitals is  
 $3s < 3p < 4s < 3d$

$\therefore$  3d has highest energy.

18. (b) Species having same number of electrons are **isoelectronic** calculating the number of electrons in each species given here, we get.

$\text{CN}^- (6 + 7 + 1 = 14)$ ;  $\text{N}_2 (7 + 7 = 14)$ ;

$\text{O}_2^{2-} (8 + 8 + 2 = 18)$ ;  $\text{C}_2^{2-} (6 + 6 + 2 = 14)$ ;

$\text{O}_2^- (8 + 8 + 1 = 17)$ ;  $\text{NO}^+ (7 + 8 - 1 = 14)$

$\text{CO} (6 + 8 = 14)$ ;  $\text{NO} (7 + 8 = 15)$

From the above calculation we find that all the species listed in choice (b) have 14 electrons each so it is the correct answer.

19. (d) ( $\Delta E$ ), The energy required to excite an electron in an atom of hydrogen from  $n = 1$  to  $n = 2$  is  $\Delta E$  (difference in energy  $E_2$  and  $E_1$ )

Values of  $E_2$  and  $E_1$  are,

$$E_1 = -1.312 \times 10^6 \text{ J mol}^{-1}$$

$$E_2 = \frac{-1.312 \times 10^6 \times (1)^2}{(2)^2} = -3.28 \times 10^5 \text{ J mol}^{-1}$$

$\Delta E$  is given by the relation,

$$\begin{aligned} \therefore \Delta E = E_2 - E_1 &= [-3.28 \times 10^5] - [-1.312 \times 10^6] \text{ J mol}^{-1} \\ &= (-3.28 \times 10^5 + 1.312 \times 10^6) \text{ J mol}^{-1} \\ &= 9.84 \times 10^5 \text{ J mol}^{-1} \end{aligned}$$

Thus the correct answer is (d)

20. (a)  $\lambda = \frac{h}{mv} = \frac{6.63 \times 10^{-34}}{1.67 \times 10^{-27} \times 1 \times 10^3}$   
 $= 3.97 \times 10^{-10} \text{ meter} = 0.397 \text{ nanometer}$

21. (b) According to Heisenberg uncertainty principle.

$$\Delta x \cdot m \Delta v = \frac{h}{4\pi}, \quad \Delta x = \frac{h}{4\pi m \Delta v}$$

$$\text{Here } \Delta v = \frac{600 \times 0.005}{100} = 0.03$$

$$\begin{aligned} \text{So, } \Delta x &= \frac{6.6 \times 10^{-34}}{4 \times 3.14 \times 9.1 \times 10^{-31} \times 0.03} \\ &= 1.92 \times 10^{-3} \text{ meter} \end{aligned}$$

22. (d) Energy required to break one mole of Cl - Cl bonds in  $\text{Cl}_2$

$$= \frac{242 \times 10^3}{6.023 \times 10^{23}} = \frac{hc}{\lambda} = \frac{6.626 \times 10^{-34} \times 3 \times 10^8}{\lambda}$$

$$\begin{aligned} \therefore \lambda &= \frac{6.626 \times 10^{-34} \times 3 \times 10^8 \times 6.023 \times 10^{23}}{242 \times 10^3} \\ &= 0.4947 \times 10^{-6} \text{ m} = 494.7 \text{ nm} \end{aligned}$$

23. (b) I.  $E = \frac{Z^2}{n^2} \times 13.6 \text{ eV} \quad \dots(\text{i})$

$$\text{or } \frac{I_1}{I_2} = \frac{Z_1^2}{n_1^2} \times \frac{n_2^2}{Z_2^2} \quad \dots(\text{ii})$$

Given  $I_1 = -19.6 \times 10^{-18}$ ,  $Z_1 = 2, n_1 = 1, Z_2 = 3$  and  $n_2 = 1$   
 Substituting these values in equation (ii).

$$-\frac{19.6 \times 10^{-18}}{I_2} = \frac{4}{1} \times \frac{1}{9}$$

$$\text{or } I_2 = -19.6 \times 10^{-18} \times \frac{9}{4} = -4.41 \times 10^{-17} \text{ J/atom}$$

24. (c) Energy of absorbed photon = Sum of the energies of emitted photon

$$\frac{hc}{\lambda} = \frac{hc}{\lambda_1} + \frac{hc}{\lambda_2} \quad \text{or } \frac{1}{\lambda} = \frac{1}{\lambda_1} + \frac{1}{\lambda_2}$$

$$\frac{1}{355 \times 10^{-9}} = \frac{1}{680 \times 10^{-9}} + \frac{1}{\lambda_2}$$

$$\frac{1}{\lambda_2} = \frac{1}{355 \times 10^{-9}} - \frac{1}{680 \times 10^{-9}} = 1.346 \times 10^6$$

$$\text{or } \lambda_2 = 1/1.346 \times 10^6 = 743 \times 10^{-9} \text{ m} = 743 \text{ nm}$$

25. (b) (a) 4 p (b) 4 s (c) 3 d (d) 3 p

According to Bohr Bury's ( $n + \ell$ )

rule, increasing order of energy (D) < (B) < (C) < (A).

**Note** : If the two orbitals have same value of ( $n + \ell$ ) then the orbital with lower value of  $n$  will be filled first.

26. (a)  $\Delta E = 2.178 \times 10^{-18} \left( \frac{1}{1^2} - \frac{1}{2^2} \right) = \frac{hc}{\lambda}$

$$2.17 \times 10^{-18} \times \frac{3}{4} = \frac{hc}{\lambda} = \frac{6.62 \times 10^{-34} \times 3 \times 10^8}{\lambda}$$

$$\lambda = \frac{6.62 \times 10^{-34} \times 3 \times 10^8 \times 4}{2.17 \times 10^{-18} \times 3} = 1.214 \times 10^{-7} \text{ m}$$

27. (a) The electronic configuration of Rubidium ( $\text{Rb} = 37$ ) is

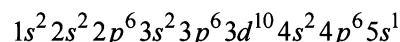

Since last electron enters in 5s orbital

$$\text{Hence } n = 5, l = 0, m = 0, s = \pm \frac{1}{2}$$

28. (a) Total energy =  $\frac{-13.6Z^2}{n^2} \text{ eV}$

where  $n = 2, 3, 4 \dots$

Putting  $n = 2$

$$E_T = \frac{-13.6}{4} = -3.4 \text{ eV}$$

29. (b) As electron of charge 'e' is passed through 'V' volt, kinetic energy of electron will be eV

$$\text{Wavelength of electron wave } (\lambda) = \frac{h}{\sqrt{2m \cdot K \cdot E}}$$

$$\lambda = \frac{h}{\sqrt{2meV}} \Rightarrow \therefore \frac{h}{\lambda} = \sqrt{2meV}$$

# Classification of Elements and Periodicity in Properties

## Section-A : JEE Advanced/ IIT-JEE

- A** 1. Electron affinity      2. Electronegativity
- B** 1. T    2. F    3. F
- C** 1. (c)    2. (c)    3. (a)    4. (a)    5. (c)    6. (a)    7. (b)  
8. (d)    9. (b)    10. (d)    11. (b)    12. (d)    13. (b)    14. (a)  
15. (a)    16. (a)
- D** 1. (a, c, d)    2. (a, b)    3. (d)
- E** 1. (i)  $O^{2-} > F^- > Na^+ > Mg^{2+}$ ; (ii)  $Na_2O_2 < MgO < ZnO < P_2O_5$ ; (iii)  $Na < Al < Mg < Si$ ; (iv)  $Ca^{2+} < Ar < Cl^- < S^{2-}$ ;  
(v)  $Mg^{2+} < Na^+ < F^- < O^{2-} < N^{3-}$ ; (vi)  $NiO < MgO < SrO < K_2O < Cs_2O$ ; (vii)  $Al^{3+} < Mg^{2+} < Li^+ < K^+$
- H** 1. (c)
- I** 1. 2

## Section-B : JEE Main/ AIEEE

1. (b)    2. (d)    3. (a)    4. (d)    5. (a)    6. (a)    7. (c)  
8. (b)    9. (b)    10. (d)    11. (a)    12. (c)    13. (c)    14. (b)    15. (a)

## Section-A JEE Advanced/ IIT-JEE

### A. Fill in the Blanks

1. Electron affinity      2. Electronegativity

### B. True / False

1. **True** : Ionisation energy decreases on moving down in group IA from Li to Cs, the reducing property should **increase** in the same order, i.e., from Li to Cs which is found to be so except an *anomaly in lithium which is found to be the strongest reducing agent*, because of its **higher oxidation potential** ( $E^\circ$ ).
2. **False** : Halogens have high electron affinities which decrease as we move down the group. However, fluorine has lower value of E.A. than chlorine which is due to its small size and more repulsion between the electron added and electrons already present. Hence the order  $Cl > Br > F$ .
3. **False** : On moving down the group 13 (III) A the basic nature of hydroxides increases. The basic nature increases as the element becomes more electropositive or acquires more metallic character when we move down a group.

### C. MCQs with One Correct Answer

1. (c) **NOTE** : Ionization potential is amount of energy required to take out most loosely bonded electron from neutral atom. Its value depends on stability of atom

(electronic configuration)

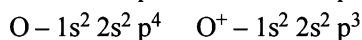

(for second ionisation potential,  $IE_2$ )

As for  $IE_2$  the electron in all the cases is to be removed from 2p orbital so it must follow the order

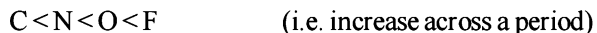

But in case of  $O^+$ , the 2p orbital is half-filled and is more stable as compared to others. So the order becomes:  $C < N < F < O$  or  $O > F > N > C$

2. (c) Amongst B, C, N and O; N has the highest first ionization energy, because of its half filled 2p orbital which is more stable.
3. (a) Ionisation potential of nitrogen is more than that of oxygen. This is because nitrogen has more stable **half-filled p-orbitals**. ( $N = 1s^2, 2s^2, 2p^3$ ,  $O = 1s^2, 2s^2, 2p^4$ )
4. (a) **TIPS/Formulae** :
- (i) Noble gases do not have covalent radii. They have only vander waal's radii.

(ii) Covalent radii is always larger than corresponding van-der Waal's radii

Atomic radius of neon being van der Waal's radius is larger than that of fluorine which is in fact is its covalent radius.

5. (c) **NOTE** : Electronegativity increases on moving from left to right in a period and decreases on moving from top to bottom in a group.

Si and P are placed in the 3<sup>rd</sup> period while C and N are placed in the 2<sup>nd</sup> period. Elements in 2<sup>nd</sup> period have higher electronegativities than those in the 3<sup>rd</sup> period. Since N has smaller size and higher nuclear charge than C, its electronegativity is higher than that of C. Similarly, the electronegativity of P is higher than that of Si. Thus, the overall order is : Si, P, C, N.

6. (a) **NOTE** : First ionisation potential increases from left to right in a period. But Mg is more stable than Al due to fully filled-3s orbitals.

IE<sub>1</sub> of Mg is higher than that of Na because of increased nuclear charge and also that of Al because in Mg a 3 s-electron has to be removed while in Al it is the 3 p-electron. The IE<sub>1</sub> of Si is, however, higher than those of Mg and Al because of its increased nuclear charge. Thus, the overall order is Na < Mg > Al < Si.

7. (b) Nitrogen, being smallest in size, can give up its lone pair of electrons most easily.

8. (d) **TIPS/Formulae** :

For isoelectronic ions, ionic size  $\propto \frac{1}{\text{atomic number}}$

Species	No. of e <sup>-</sup>	At. No.
N <sup>-3</sup>	10	7
O <sup>-2</sup>	10	8
F <sup>-</sup>	10	9
Na <sup>+</sup>	10	11

∴ Na<sup>+</sup> is largest in size.

9. (b) **NOTE** : Ionisation energy increases with increasing atomic number in a period, while it decreases on moving down a groups. IE of element with electronic configuration (d) is lowest because of its biggest size. Among the remaining three elements of the same period (3rd). IE of element with electronic configuration (b) is the highest due to greater stability of the exactly half-filled 3 p-subshell.

10. (d) The electrons are not filled in d-subshell monotonically with increase in atomic number, among transition elements.

11. (b) **TIPS/Formulae** :

(i) Ion having half filled or full filled orbital have extra stability.

(ii) Larger the size of cation more will be its stability Pb<sup>2+</sup> (5d<sup>10</sup> 6s<sup>2</sup>), has the most stable +2 oxidation state because here the d-orbital is completely filled and is more stable than Fe<sup>2+</sup> (3d<sup>6</sup>). Again Ag<sup>+</sup> (4d<sup>10</sup>) is more stable as here again the d-orbital is completely filled

and Ag<sup>2+</sup> is not easily obtained. Pb<sup>2+</sup> is more stable compared to Sn<sup>2+</sup> (4d<sup>10</sup> 5s<sup>2</sup>) because of its large size.

12. (d) The electronic configuration of the given ions are as follows.

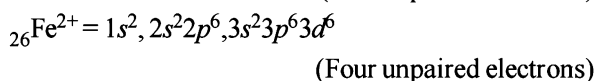
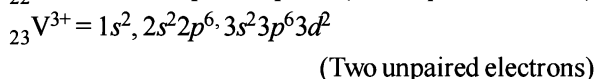
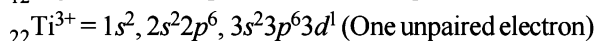

13. (b) Effective nuclear charge (i.e. Z/e ratio) decreases from F<sup>-</sup> to N<sup>3-</sup> hence the radii follows the order:

F<sup>-</sup> < O<sup>2-</sup> < N<sup>3-</sup>. Z/e for F<sup>-</sup> = 9/10 = 0.9, for O<sup>2-</sup> = 8/10 = .8, for N<sup>3-</sup> = 7/10 = 0.7

14. (a) Non-metallic oxides are acidic and acidic character decreases with increase in metallic character.

15. (a) **TIPS/Formulae** :

(i) Hydrogen bonding increases the boiling point.

(ii) Hydrogen bonds are formed in compounds having F or O or N with hydrogen

S, Se, Te cannot undergo hydrogen bond formation because of their larger size and lower electronegativity values.

16. (a) Non-metallic oxides are acidic and metallic oxides are basic. Thus the acidic order is

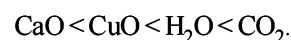

#### D. MCQs with One or More than One Correct

1. (a,c,d) Periodic table does not help to predict the stable valency states of the elements.

2. (a, b) **TIPS/Formulae** :

For dissolution, Hydration energy > Lattice energy.

BaSO<sub>4</sub> is sparingly soluble in water because its hydration energy is lesser than the lattice energy and thus ions are not separated from each other. On the contrary in Na<sub>2</sub>SO<sub>4</sub>, the hydration energy is more than its lattice energy. Thus ions are separated from each other and pass in solution state.

3. (d) Higher the (+) charge, smaller will be radii.

#### E. Subjective Problems

1. (i) O<sup>2-</sup> > F<sup>-</sup> > Na<sup>+</sup> > Mg<sup>2+</sup>

**NOTE** : All the above ions are isoelectronic having 10 electron each.

In such case the greater the nuclear charge, the greater is the attraction for electrons and smaller is the ionic radius. Hence O<sup>2-</sup> has the highest and Mg<sup>2+</sup> has the least ionic size.

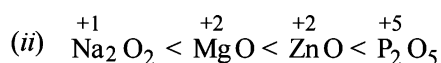

Among oxides the acidic strength increases with oxidation state. So Na<sub>2</sub>O<sub>2</sub> is least acidic and P<sub>2</sub>O<sub>5</sub> is

most acidic. Further  $\text{Na}_2\text{O}_2$  and  $\text{MgO}$  are basic,  $\text{ZnO}$  is amphoteric and  $\text{P}_2\text{O}_5$  is acidic.

- (iii) The first ionization potential of the 3rd period elements follows the order :

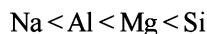

**NOTE :** Ionisation energy **increases across a period** but not regularly.  $\text{Mg}$  ( $1s^2, 2s^2p^6, 3s^2$ ) is more stable because the electron is to be removed from  $3s$  which is difficult as compared to  $\text{Al}$  ( $1s^2, 2s^2p^6, 3s^2p^1$ ) where electron is to be removed from  $3p$ .

- (iv)  $\text{Ca}^{2+} < \text{Ar} < \text{Cl}^- < \text{S}^{2-}$ ; All of these are isoelectronic. In such cases the greater the nuclear charge, the greater is the attraction for electrons and smaller is ionic size.

$$\text{ionic radius} \propto \frac{1}{\text{effective nuclear charge}}$$

- (v) Increasing order of ionic size :

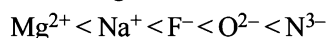

**NOTE :** All the above ions are isoelectronic having 10 electrons each.

In such a case the greater the nuclear charge, the greater is the attraction for electrons and smaller is the ionic radius. Hence  $\text{N}^{3-}$  has the highest and  $\text{Mg}^{2+}$  has the least ionic size.

- (vi) Increasing order of basic character :



The basic character of oxides increases when we move

down the group. So,  $\text{K}_2\text{O} < \text{Cr}_2\text{O}$  and  $\text{MgO} < \text{SrO}$ .

Further higher the group number lesser is the basic character. Hence  $\text{NiO}$  is the least basic.

- (vii)  $\text{Al}^{3+} < \text{Mg}^{2+} < \text{Li}^+ < \text{K}^+$

In these  $\text{Al}^{3+}$  &  $\text{Mg}^{2+}$  are isoelectronic species, so in these size decreases with increase in atomic number because increase in atomic number decreases  $Z_{\text{eff}}$

$$\text{Size} \propto \frac{1}{Z_{\text{eff}}}$$

In  $\text{Li}^+$  &  $\text{K}^+$ ,  $\text{K}^+$  is bigger in size than  $\text{Li}^+$  because on moving from top to bottom in a group, the group size increases.

2.  $\text{C}$  ( $1s^2 2s^2 p^2$ ) has half filled orbitals in its excited state ( $\text{C} \rightarrow 1s^2 2s^1 p^3$ ) due to which it becomes more stable and hence  $\text{IE}_1$  for  $\text{C}$  is greater than  $\text{B}$ .

Further for second ionization energy ( $\text{IE}_2$ ) in  $\text{C}^+$  ( $1s^2 2s^2 p^1$ ) the electron is to be removed from  $2p$  which is easy as compared to  $\text{B}^+$  ( $1s^2 2s^2$ ), where it has to be removed from  $2s$ .

### H. Assertion & Reason Type Questions

1. (c) Assertion is correct but reason is incorrect because the energy of  $2s$  orbital is less than  $2p$  orbital.

### I. Integer Value Correct Type

1. Fluorine generally shows 0 and  $-1$  oxidation states while sodium shows 0 and  $+1$  oxidation state.

## Section-B JEE Main/ AIEEE

1. (b) According to modern periodic law, the properties of the elements are repeated after certain regular intervals when these elements are arranged in order of their increasing atomic numbers.

2. (d)  $\text{Na}_2\text{O}$  (basic),  $\text{SO}_2$  and  $\text{B}_2\text{O}_3$  (acidic) and  $\text{ZnO}$  is amphoteric.

3. (a)  $\text{O}^{2-}$  and  $\text{F}^-$  are isoelectronic. Hence have same number of shells, therefore greater the nuclear charge smaller will be the size i.e.

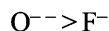

further  $\text{Li}^+$  and  $\text{B}^{3+}$  are isoelectronic. therefore

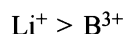

Hence the correct order of atomic size is.

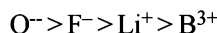

4. (d) As the size increases the basic nature of oxides changes to acidic nature i.e., acidic nature increases.

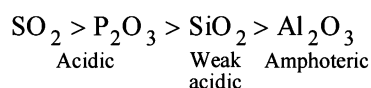

$\text{SO}_2$  and  $\text{P}_2\text{O}_3$  are acidic as their corresponding acids  $\text{H}_2\text{SO}_3$  and  $\text{H}_3\text{PO}_3$  are strong acids.

5. (a)  $\text{O}^-$  ion exerts a force of repulsion on the incoming electron. The energy is required to overcome it.

6. (a)  $\text{CaO}$  is basic as it forms strong base  $\text{Ca(OH)}_2$  on reaction with water.

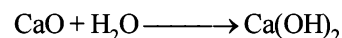

$\text{CO}_2$  is acidic as it dissolves in water forming unstable carbonic acid.



Silica ( $\text{SiO}_2$ ) is insoluble in water and acts as a very weak acid.

$\text{SnO}_2$  is amphoteric as it reacts with both acid and base.

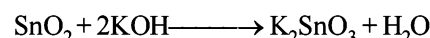
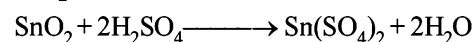

7. (c) In a period the value of ionisation potential increases from left to right with breaks where the atoms have some what stable configuration. In this case  $\text{N}$  has half filled stable orbitals. Hence has highest ionisation energy. Thus the correct order is

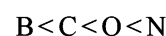

and not as given in option (c)

### Classification of Elements and Periodicity in Properties

8. (b) The alkali metals are highly reactive because their first ionisation potential is very low and hence they have great tendency to lose electron to form unipositive ion.
- NOTE :** On moving down group- I from Li to Cs ionisation enthalpy decreases hence the reactivity increases. The halogens are most reactive elements due to their low bond dissociation energy, high electron affinity and high enthalpy of hydration of halide ion. However their reactivity decreases with increase in atomic number
9. (b) In hydrides of 15<sup>th</sup> group elements, basic character decreases on descending the group i.e.  
 $\text{NH}_3 > \text{PH}_3 > \text{AsH}_3 > \text{SbH}_3$ .
10. (d) All the given species contains 10 e<sup>-</sup> each i.e. isoelectronic.  
 For isoelectronic species anion having high negative charge is largest in size and the cation having high positive charge is smallest.
11. (a) On moving across a period ionisation energy increases hence the electropositive nature of metals decreases therefore the ease of formation of ion also decreases and hence the basic character decreases. Further basic character of alkali metals oxides increases from Li<sub>2</sub>O to Cs<sub>2</sub>O. Hence the correct order will be  
 $\text{Al}_2\text{O}_3 < \text{MgO} < \text{Na}_2\text{O} < \text{K}_2\text{O}$
12. (c) Among isoelectronic species ionic radii increases as the charge increases.  
 Order of ionic radii  $\text{Ca}^{2+} < \text{K}^+ < \text{Cl}^- < \text{S}^{2-}$   
 The number of electrons remains the same but nuclear charge increases with increase in the atomic number causing decrease in size.
13. (c) On moving along a period from left to right I.E. increases and on moving down a group I.E. decreases. hence correct order is :  
 $\text{Ba} < \text{Ca} < \text{Se} < \text{S} < \text{Ar}$
14. (b)  $\therefore \text{For Na} \longrightarrow \text{Na}^+ + \text{e}^- \quad \text{IE}_1 = 5.1 \text{ eV}$   
 $\therefore \text{For Na}^+ + \text{e}^- \longrightarrow \text{Na} \quad \text{EF} = -5.1 \text{ eV}$   
 (because the reaction is reverse)
15. (a) For isoelectronic species, size of anion increases as negative charge increases. Thus the correct order is  
 $\text{N}^{3-} > \text{O}^{2-} > \text{F}^-$   
 (1.71) (1.40) (1.36)

## Section-A : JEE Advanced/ IIT-JEE

- A** 1.  $\text{CO}_2$       2.  $\text{HCOOH}$  and  $\text{CH}_3\text{COOH}$       3. 2      4.  $\text{sp}^3$       5. planar  
6. Three centred two electron bond or banana bond      7. Increases, decreases
- B** 1. T      2. F      3. T      4. F      5. F      6. F      7. F
- C** 1. (c)      2. (d)      3. (a)      4. (a)      5. (c)      6. (b)      7. (c)      8. (a)  
9. (a)      10. (b)      11. (b)      12. (d)      13. (c)      14. (b)      15. (a)      16. (d)  
17. (c)      18. (c)      19. (a)      20. (c)      21. (a)      22. (b)      23. (a)      24. (c)  
25. (a)      26. (a)      27. (b)      28. (b)      29. (d)      30. (c)      31. (d)      32. (c)  
33. (b)      34. (c)      35. (d)      36. (b)      37. (b)      38. (d)      39. (a)      40. (d)  
41. (b)      42. (a)      43. (b)      44. (a)      45. (b)      46. (c)      47. (a)      48. (b)  
49. (d)      50. (d)      51. (a)      52. (a)      53. (d)      54. (b)      55. (c)      56. (a)
- D** 1. (a, c)      2. (b, c, d)      3. (a, c)      4. (b, c)      5. (b, c)      6. (a, c)
- E** 3.  $12\sigma, 6\pi$       5. (i)  $\text{F}_2 < \text{Cl}_2 < \text{O}_2 < \text{N}_2$ ; (ii)  $\text{S} < \text{Cl} < \text{N} < \text{O} < \text{F}$ ; (iii)  $\text{O}_2[\text{AsF}_4] > \text{O}_2 > \text{KO}_2$   
6. 80.09%      7. +2, -1      8.  $1s^2, 2s^2 2p^6, 3s^2 3p^6 3d^1$       10. 2
- F** 1. (c)
- H** 1. (a)      2. (c)
- I** 1. 0      2. 6      3. 4      4. 4

## Section-B : JEE Main/ AIEEE

1. (a)      2. (b)      3. (a)      4. (c)      5. (b)      6. (b)      7. (a)      8. (a)  
9. (b)      10. (b)      11. (a)      12. (d)      13. (a)      14. (c)      15. (d)      16. (b)  
17. (b)      18. (d)      19. (c)      20. (c)      21. (a)      22. (b)      23. (d)      24. (c)  
25. (b)      26. (d)      27. (b)      28. (c)      29. (a)      30. (a)      31. (c)      32. (b)  
33. (d)      34. (c)

## Section-A JEE Advanced/ IIT-JEE

### A. Fill in the Blanks

1.  $\text{CO}_2$ ; Bond angle in  $\text{CH}_4$  is  $109^\circ.28'$ , in  $\text{H}_2\text{O}$  it is 105 and in  $\text{CO}_2$  it is  $180^\circ$ . So it is maximum in case of  $\text{CO}_2$

2.  $\text{H}-\overset{\text{O}}{\parallel}{\text{C}}-\text{OH}$  and  $\text{CH}_3-\overset{\text{O}}{\parallel}{\text{C}}-\text{OH}$  form strongest hydrogen bonds because of largest difference in electronegativities of bonded atoms.

3. 2;  $\text{N}\equiv\text{N}$  ( $\text{N}_2$ ) has 1  $\sigma$  and 2  $\pi$  bonds. (A triple bond consists of 1  $\sigma$  and 2  $\pi$  bonds)

4.  $\text{sp}^3$ ; Hybridisation (H) =  $\frac{1}{2}$  [No. of valence electron in central atom + No. of monovalent atoms - Charge on cation + Charge on anion]

For N in  $\text{NH}_4^+$ , hybridisation (H) =  $\frac{1}{2}(5 + 4 - 1 + 0) = 4$

$\therefore \text{sp}^3$  hybridisation.

5. **Planar**;  $\overset{+}{\text{C}}\text{H}_3$  is a carbocation and such a species has a planar shape.
6. Three centred two electron bonds or **banana bond**;

**NOTE** : The formation of three centred two electron bond is due to one empty  $\text{sp}^3$  orbital of one of the B atom, 1s orbital of the bridge hydrogen atom and one of the  $\text{sp}^3$  (filled) orbital of the other B-atom. This forms a delocalized orbital covering the three nuclei giving the shape of a banana. Thus also known as banana bonds.

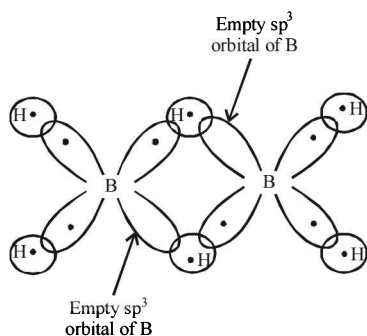
7. **Increases, decreases;**

$\therefore$  Bond order in  $N_2 = 3$  and Bond order in  $N_2^+ = 2.5$

Thus conversion of  $N_2$  to  $N_2^+$  decreases bond order (from 3 to 2.5) and hence increases the N – N bond distance.

[ $\therefore$  Bond distance increases with decrease in B.O.]

Bond order in  $O_2 = 2$  and Bond order in  $O_2^+ = 2.5$

**NOTE :** Thus conversion of  $O_2$  to  $O_2^+$  increases bond order (from 2 to 2.5) hence decrease O – O bond distance.

**B. True / False**

1. **True :** Sigma bond is formed by the overlapping of two *s*-orbitals or one *s* and one *p* or the two *p* orbitals of the two different atoms. Thus linear overlap of two *p*-orbitals results in formation of a  $\sigma$ -bond.

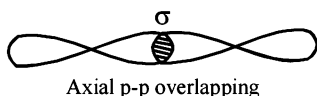

2. **False :** Symmetrical molecules with polar bonds have zero dipole moment.
3. **True :**  $SnCl_2$  has 2 bond pairs and one lone pair of electrons. It is  $sp^2$  hybridised and is trigonal planar in shape.
4. **False :** Only two orbitals are used since C in benzene is in  $sp^2$  hybridised state.
5. **False :**  $sp^2$  hybrid orbitals do not have equal *s* and *p* character. They have 33.3% *s*-character and 66.7% *p*-character.
6. **False :** The presence of polar bonds in a polyatomic molecule does not always lead to a definite dipole moment. This is because the dipole moment is a vector quantity and when the bond moment of one bond is cancelled by the equal but opposite bond moment due to other bond(s), the molecule has zero dipole moment, e.g.  $CO_2$ ,  $CH_4$ ,  $CCl_4$  etc.
7. **False :** The C – F distance is less than the C – Cl, although the former involves more charge separation. However, here bond distance has more dominating effect causing dipole moment of  $CH_3Cl$  to be more than that of  $CH_3F$ .

**C. MCQ with One Correct Answer**

1. (c) In KCN, ionic bond is present between  $K^+$  and  $CN^-$  and covalent bonds are present between carbon and nitrogen  $C \equiv N$ .
2. (d)  $\therefore$  after forming the bonds, C has only 6  $e^-$  in its valence shell.

3. (a)  $X^+ Y^-$   
 $\therefore$  Electropositive elements forms cation and electronegative elements forms anion.  
 Except this all compounds are ionic.

4. (a)  $H_2$   $H-H$

5. (c)  $N \equiv N$   $:N:::N:$

6. (b)  $\therefore$  It forms hydrogen bonds with water

7. (c) **NOTE :** Dipole moment is vector quantity  
 In trigonal planar geometry (for  $sp^2$  hybridisation), the vector sum of two bond moments is equal and opposite to the dipole moment of third bond.

8. (a) **NOTE :** Isoelectronic species have same number of electrons.

Electrons in  $CO = 6 + 8 = 14$

Electrons in  $CN^- = 6 + 7 + 1 = 14$

Electrons in  $O_2^- = 8 + 8 + 1 = 17$

Electrons in  $O_2^+ = 8 + 8 - 1 = 15$

$\therefore$  CO and  $CN^-$  are isoelectronic.

9. (a) **TIPS/Formulae :**

$$\text{Hybridisation} = \frac{1}{2} (V + M - C + A)$$

where; V = no. of electron in valence shell of central atom

M = no. of monovalent atoms, C = charge on cation, A = charge on anion

(i)  $CO_2, H = \frac{1}{2} (4 + 0 - 0 + 0) = 2$

$\therefore$  sp hybridisation

(ii)  $SO_2, H = \frac{1}{2} (6 + 0 - 0 + 0) = 3$

$\therefore$   $sp^2$  hybridisation

(iii)  $NO_2$  has V shaped structure.

(iv)  $ClO_2$  has V shaped structure.

$\therefore$   $CO_2$  having sp hybridisation has linear shape.

10. (b) **TIPS/Formulae :**

(i) Dipole moment is vector quantity. When vector sum of all dipoles in molecule will be zero, then molecule will not have net dipole moment.

(ii) **NOTE :** For net dipole moment to be equal to zero, all the atoms attached to central atom must be identical and geometry must be regular.

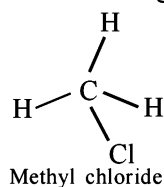

Methyl chloride

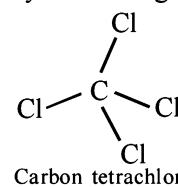

Carbon tetrachloride

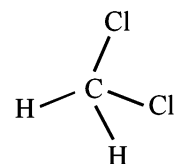

Methylene chloride

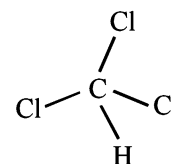

Chloroform

∴ Carbon tetrachloride having regular geometry and identical atoms attached to bonds has zero dipole moment.

11. (b) In regular tetrahedral structure, dipole moment of one bond is cancelled by opposite dipole moment of the other bonds.
12. (d) **TIPS/Formulae** : Hydrogen bonding is formed in those compounds in which F or O or N atoms are attached to hydrogen atom.  
∴ HCl does not have F or N or O  
∴ It does not form hydrogen bond.

13. (c) Ionic bond or electrovalent between  $\text{Cu}^{2+}$  and  $\text{SO}_4^{2-}$ ,

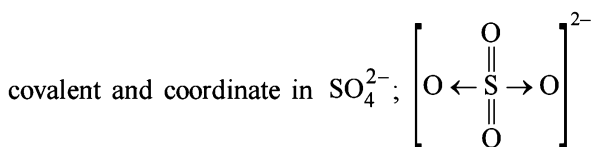

ion.

14. (b) **TIPS/Formulae** :  $sp$  type of hybridization involves the intermixing of one  $s$  and one  $p$  (say  $p_x$ ) orbitals to give two equivalent hybrid orbitals, known as  $sp$  hybrid orbitals.

The two  $sp$  hybrid orbitals are directed diagonally, i.e., in a straight line with an angle of  $180^\circ$  (**collinear orbitals**). The other two  $p$  orbitals (say  $p_y$  and  $p_z$ ) remain pure.

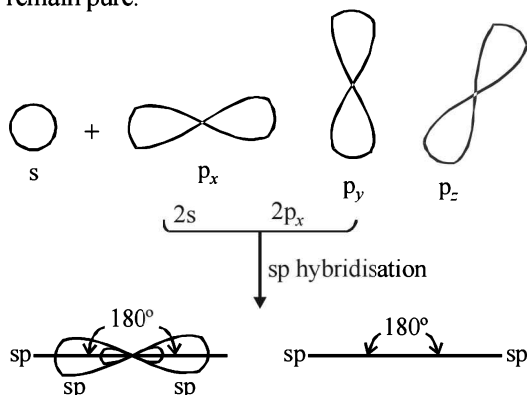

15. (a) **NOTE THIS STEP** : Write the electronic configuration of each species according to molecular orbital theory.

NO ( $15e^-$ ) –  $\sigma 1s^2, \sigma^* 1s^2, \sigma 2s^2, \sigma^* 2s^2, \sigma 2p_x^2,$

$$\{\pi 2p_y^2 = \pi 2p_z^2, \{\pi^* 2p_y^1 = \pi^* 2p_z^1$$

**1 unpaired electron.**

CO ( $14e^-$ ) –  $\sigma 1s^2, \sigma^* 1s^2, \sigma 2s^2, \sigma^* 2s^2,$

$$\{\pi 2p_y^2 = \pi 2p_z^2, \sigma 2p_x^2$$

**no unpaired electron**

$\text{CN}^-$  ( $14e^-$ ) –  $\sigma 1s^2, \sigma^* 1s^2, \sigma 2s^2, \sigma^* 2s^2,$

$$\{\pi 2p_y^2 = \pi 2p_z^2, \sigma 2p_x^2$$

$\text{O}_2$  ( $16e^-$ ) –  $\sigma 1s^2, \sigma^* 1s^2, \sigma 2s^2, \sigma^* 2s^2, \sigma 2p_x^2,$   
 $\{\pi 2p_y^2 = \pi 2p_z^2, \{\pi^* 2p_y^1 = \pi^* 2p_z^1;$

**Two unpaired electrons.**

16. (d) In covalent bonds between two identical non-metal atoms share the pair of electrons equally between them, e.g. :  $\text{F}_2, \text{O}_2, \text{N}_2$ .

17. (c) **NOTE** : Greater the difference between electronegativities of two covalently bonded atoms more will be strength of hydrogen bond.

∴ F – H ..... F bond is strongest due to largest difference in electronegativity of atoms and smallest size of F atom.

18. (c) **TIPS/Formulae** :  $H = \frac{1}{2}(V + M - C + A)$

$$\text{For } \text{SO}_2, H = \frac{1}{2}(6 + 0 + 0 - 0) = 3$$

∴  $sp^2$  hybridisation.

19. (a) **NOTE** : Compounds having F or O or N attached to H form hydrogen bond.

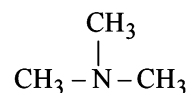
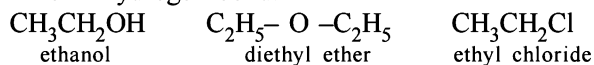

Trimethyl amine

∴ Ethanol having H attached to O atom will form hydrogen bond. Rest of the compounds do not form hydrogen bonds.

20. (c) From amongst given species  $\text{PH}_3, \text{NH}_3$  and  $\text{SbH}_3$  are all  $sp^3$  hybridised. Their central atom has both bond pair as well as lone pair of electrons. The lone pair occupy the fourth orbital.  $\text{CH}_3^+$  has only three pairs of electrons so it is  $sp^2$  hybridised.

21. (a) **TIPS/Formulae** : Compound having  $sp$  hybridisation will have linear shape.

∴  $\text{CO}_2$  or ( $\text{O}=\text{C}=\text{O}$ ) which has C in  $sp$  hybrid state has linear shape.

22. (b) **TIPS/Formulae** : Dipole moment of compound having regular geometry and same type of atoms is zero. It is vector quantity.

The zero dipole moment of  $\text{BF}_3$  is due to its symmetrical (triangular planar) structure. The three fluorine atoms lie at the corners of an equilateral triangle with boron at the centre.

**NOTE** : The vectorial addition of the dipole moments of the three bonds gives a net sum of zero because the resultant of any two dipole moments is equal and opposite to the third. The dipole moment of  $\text{NH}_3$  is 1.46 D indicating its unsymmetrical structure. The dipole moment of  $\text{CH}_2\text{Cl}_2$  (the molecule uses  $sp^3$  hybridisation but is not symmetric) is 1.57D.

23. (a) **TIPS/Formulae** : Molecule having  $sp^3$  hybridisation and one lone pair of electron will have pyramidal structure.

(i)  $\text{CO}_3^{2-}$  and  $\text{NO}_3^-$  have tetrahedron structure.

(ii) In  $\text{PCl}_3$ , P is  $sp^3$  hybridised and has one lone pair of electrons, hence it is pyramidal in shape.

24. (c) **TIPS/Formulae** :

4  $\sigma$  bonds –  $sp^3$  hybridisation

2  $\sigma$  and 2  $\pi$  bonds –  $sp^2$  hybridisation



1σ and 3π bonds – sp hybridisation  
[For hybridization only σ-bonds are considered]

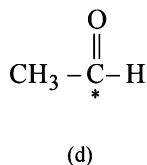
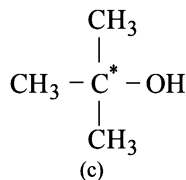
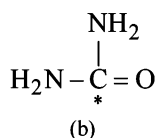
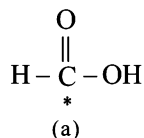

(a) 3σ, 1π (b) 3σ, 1π (c) 4σ (d) 3σ, 1π

∴ (CH<sub>3</sub>)<sub>3</sub>COH has 4σ bonds and thus it has sp<sup>3</sup> hybridisation.

25. (a) O<sub>2</sub><sup>-</sup> (17e<sup>-</sup>) – K K σ 2s<sup>2</sup> σ\* 2s<sup>2</sup> σ 2p<sub>x</sub><sup>2</sup>,  
 $\{\pi 2p_y^2 = \pi 2p_z^2, \{\pi^* 2p_y^2 = \pi^* 2p_z^1\}$   
 Thus, O<sub>2</sub><sup>-</sup> has one unpaired electron; hence it is paramagnetic. Other species have no unpaired electron. All of them have 14 electrons.

26. (a)  $H = \frac{1}{2} (V + M - C + A)$

where H = No. of orbitals involved in hybridisation (viz. 2, 3, 4, 5, 6) and hence nature of hybridisation (viz. sp<sup>2</sup>, sp<sup>3</sup>, sp<sup>3</sup>d, sp<sup>3</sup>d<sup>2</sup>) can be ascertained.

V = No. of electrons in valence shell of the central atom, M = No. of monovalent atoms, C = Charge on cation, A = Charge on anion,

For ClO<sub>2</sub><sup>-</sup>, we have,  $H = \frac{1}{2} (7 + 0 - 0 + 1)$

⇒  $H = \frac{1}{2} (7 + 1) = 4$  or sp<sup>3</sup> hybridisation as 4 orbitals are involved

27. (b) H<sub>2</sub>O molecule can form four hydrogen bonds per molecule, two via lone pairs and two via hydrogen atoms.

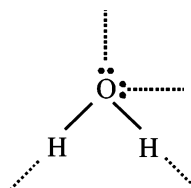

28. (b) In N<sub>2</sub>, similar atoms are linked to each other and thus there is no polarity.

29. (d) No. of e<sup>-</sup> in CH<sub>3</sub><sup>+</sup> = 6 + 3 - 1 = 8  
 No. of e<sup>-</sup> in H<sub>3</sub>O<sup>+</sup> = 3 + 8 - 1 = 10  
 No. of e<sup>-</sup> in NH<sub>3</sub> = 7 + 3 = 10  
 No. of e<sup>-</sup> in CH<sub>3</sub><sup>-</sup> = 6 + 3 + 1 = 10

∴ H<sub>3</sub>O<sup>+</sup>, NH<sub>3</sub> and CH<sub>3</sub><sup>-</sup> are isoelectronic.

30. (c) TIPS/Formulae :

- (i) Non metallic oxides are more covalent (or less ionic) as compared to metallic oxides.  
 (ii) Higher the polarising power of cation (higher for higher oxidation state of similar size cations) more will be covalent character.

- (i) P<sub>2</sub>O<sub>5</sub> will be more covalent than other metallic oxides.  
 (ii) Oxidation state of Mn is + 7 in Mn<sub>2</sub>O<sub>7</sub>, oxidation state of Cr in CrO<sub>3</sub> is + 6 and oxidation state of Mn is + 2 in MnO.

∴ MnO is most ionic.

**NOTE :** P<sub>2</sub>O<sub>5</sub>, being a non-metallic oxide will definitely be more covalent than the other metallic oxides. Further, we know that higher the polarising power of the cation (higher for higher oxidation state of the similar size cations) more will be the covalent character. Here Mn is in +7 O.S in Mn<sub>2</sub>O<sub>7</sub>, Cr in +6 in CrO<sub>3</sub> and Mn in +2 in MnO. So MnO is the most ionic and Mn<sub>2</sub>O<sub>7</sub> is the most covalent.

31. (d) O<sub>2</sub> = Oxygen (Z = 8) has following molecular orbital configuration of O<sub>2</sub>.

O<sub>2</sub> (16e<sup>-</sup>) = σ 1s<sup>2</sup>, σ\* 1s<sup>2</sup>, σ 2s<sup>2</sup>, σ\* 2s<sup>2</sup>, σ 2p<sub>x</sub><sup>2</sup>, {π 2p<sub>y</sub><sup>2</sup> = π 2p<sub>z</sub><sup>2</sup>, {π\* 2p<sub>y</sub><sup>1</sup> = π\* 2p<sub>z</sub><sup>1</sup> i.e., 2 unpaired and 14 paired electrons.

32. (c) Structure of a molecule can be ascertained by knowing the number of hybrid bonds in the molecule. Thus

In NF<sub>3</sub> :  $H = \frac{1}{2} (5 + 3 - 0 + 0) = 4$

Thus N in NF<sub>3</sub> is sp<sup>3</sup> hybridized as 4 orbitals are involved in bonding.

In NO<sub>3</sub><sup>-</sup> :  $H = \frac{1}{2} (5 + 0 - 0 + 1) = 3$

Thus N in NO<sub>3</sub><sup>-</sup> is sp<sup>2</sup> hybridized as 3 orbitals are involved in bonding

In BF<sub>3</sub> :  $H = \frac{1}{2} (3 + 3 - 0 + 0) = 3$

Thus B in BF<sub>3</sub> is sp<sup>2</sup> hybridized and 3 orbitals are involved in bonding

In H<sub>3</sub>O<sup>+</sup> :  $H = \frac{1}{2} (6 + 3 - 1 + 0) = 4$

Thus O in H<sub>3</sub>O<sup>+</sup> is sp<sup>3</sup> hybridized as 4 orbitals are involved in bonding.

Thus, isostructural pairs are [NF<sub>3</sub>, H<sub>3</sub>O<sup>+</sup>] and

[NO<sub>3</sub><sup>-</sup>, BF<sub>3</sub>].

33. (b) Calcium carbide is an ionic compound (Ca<sup>2+</sup> C<sup>2-</sup>) which produces acetylene on reacting with water. Thus the structure of C<sup>2-</sup> is [C≡C]<sup>2-</sup>. It has one σ and two π bonds. [∴ A triple bond consists of one σ and two π-bonds]

34. (c) (a)  $\left[ \begin{array}{c} \text{H} \\ | \\ \text{H}-\text{N}-\text{H} \\ | \\ \text{H} \end{array} \right]^+ [\text{Cl}]^-$  – It has ionic and non-polar covalent bond  
 (b) H–C≡N – It has ionic and polar covalent bonds.

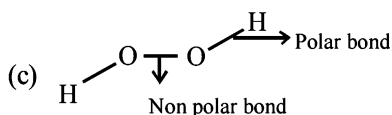

It has polar and non polar both type of covalent bonds.

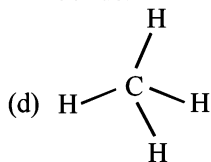

It has non polar covalent bonds only.

35. (d) Critical temperature of water is higher than  $O_2$  because  $H_2O$  molecule has dipole moment which is due to its V-shape.

36. (b) TIPS/Formulae :  $H = \frac{1}{2}(V + M - C + A)$

(i)  $CO_2$ ;  $H = \frac{1}{2}(4 + 0 - 0 + 0) = 2$   
 $\therefore sp$  hybridisation.

(ii)  $SO_2$ ;  $H = \frac{1}{2}(6 + 0 - 0 + 0) = 3$   
 $\therefore sp^2$  hybridisation.

(iii)  $CO$ ;  $H = \frac{1}{2}(4 + 0 - 0 + 0) = 2$   
 $\therefore sp$  hybridisation.

37. (b)  $H = \frac{1}{2}(3 + 3 + 0 - 0) = 3$

$\therefore$  Boron, in  $BF_3$ , is  $sp^2$  hybridised leading to trigonal planar shape.

38. (d) KEY CONCEPT

(i) Bond length  $\propto \frac{1}{\text{Bond order}}$

(ii) Bond order is calculated by either the help of molecular orbital theory or by resonance.

(i) Bond order of CO as calculated by molecular orbital theory =  $3 \left\{ \text{b.o.} = \frac{1}{2}[N_b - N_a] \right\}$

(ii) Bond order of  $CO_2$  (by resonance method)  
 $= \frac{\text{No. of bonds in all possible sides}}{\text{No. of resonating structure}} = \frac{4}{2} = 2$

(iii) Bond order in  $CO_3^{2-}$  (by resonance method)  
 $= \frac{4}{3} = 1.33$

$\therefore$  Order of bond length of C - O is  $CO < CO_2 < CO_3^{2-}$

39. (a) Hybridisation of S in  $H_2S = \frac{1}{2}(6 + 2 + 0 - 0) = 4$

$\therefore$  S has  $sp^3$  hybridisation and 2 lone pair of electrons in  $H_2S$

$\therefore$  It has angular geometry and so it has non-zero value of dipole moment.

40. (d) The structure of species can be predicted on the basis of hybridisation which in turn can be known by knowing the number of hybrid orbitals (H) in that species

$$H = \frac{1}{2} \left[ \begin{array}{cccc} \text{No. of electrons} & \text{No. of mono-} & \text{charge} & \text{charge} \\ \text{in valence} & \text{valent atoms} & \text{on} & \text{on} \\ \text{shell (H)} & \text{(X)} & \text{anion (A)} & \text{cation (C)} \end{array} \right]$$

$$= \frac{1}{2}(6 + 4 + 0 - 0) = 5$$

For  $SF_4$ : S is  $sp^3d$  hybridised in  $SF_4$ . Thus  $SF_4$  has 5 hybrid orbitals of which only four are used by F, leaving one lone pair of electrons on sulphur.

For  $CF_4$ :  $H = \frac{1}{2}[4 + 4 + 0 - 0] = 4 \therefore sp^3$  hybridisation

Since all the four orbitals of carbon are involved in bond formation, no lone pair is present on C having four valence electrons

For  $XeF_4$ :  $H = \frac{1}{2}(8 + 4 + 0 - 0) = 6, \therefore sp^3d^2$  hybridization of the six hybrid orbitals, four form bond with F, leaving behind two lone pairs of electrons on Xe.

41. (b) For  $NO_2^+$ :  $H = \frac{1}{2}(5 + 0 + 0 - 1) = 2;$

$\therefore sp$  hybridisation

For  $NO_3^-$ :  $H = \frac{1}{2}[5 + 0 + 1 - 0] = 3;$

$\therefore sp^2$  hybridisation

For  $NH_4^+$ :  $H = \frac{1}{2}[5 + 4 + 0 - 1] = 4;$

$\therefore sp^3$  hybridisation

42. (a) Number of electrons in each species are

$$CN^- = 6 + 7 + 1 = 14, CO = 6 + 8 = 14$$

$$NO^+ = 7 + 8 - 1 = 14$$

Each of the species has 14 electrons which are distributed in MOs as below

$$\sigma 1s^2, \sigma^* 1s^2, \sigma 2s^2, \sigma^* 2s^2, \{\pi 2p_y^2 = \pi 2p_z^2, \sigma 2p_x^2\}$$

$$\text{Bond order} = \frac{10 - 4}{2} = 3$$

43. (b) TIPS/Formulae :  $H = \frac{1}{2}[V + M - C + A]$

Hybridisation of N in  $NH_3$

$$= \frac{1}{2}[5 + 3 - 0 + 0] = 4 \therefore sp^3$$

Hybridisation of Pt in  $[PtCl_4]^{2-}$

$$= \frac{1}{2}[2 + 4 - 0 + 2] = 4 \therefore dsp^2$$

Hybridisation of P in  $PCl_5$

$$= \frac{1}{2}[5 + 5 - 0 + 0] = 5 \therefore sp^3d$$

Hybridisation of B in  $BCl_3$

$$= \frac{1}{2}[3 + 3 - 0 + 0] = 3 \therefore sp^2$$

44. (a)  $H_3N \rightarrow BF_3$  where both N, B are attaining tetrahedral geometry.

45. (b) NOTE THIS STEP : Write configuration of all species. Half filled and full filled orbitals are more stable as compared to nearly half filled and nearly full filled orbitals.

$\text{Li}^- = 1s^2, 2s^2$ ;  $\text{Be}^- = 1s^2, 2s^2, 2p^1$   
 $\text{B}^- = 1s^2, 2s^2, 2p^2$ ;  $\text{C}^- = 1s^2, 2s^2, 2p^3$   
 $\therefore \text{Be}^-$  will be least stable. It has lowest I.E.

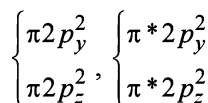
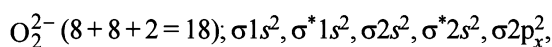
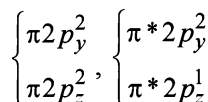
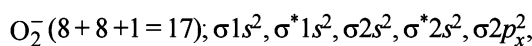
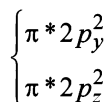
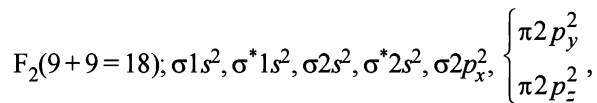
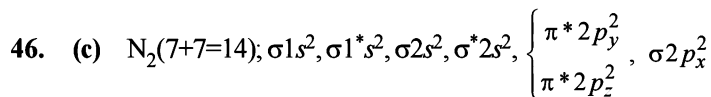

$\therefore \text{O}_2^-$  is the only species having unpaired electron.

47. (a) **NOTE** : Isoelectronic species have same number of electrons and isostructural species have same type of hybridisation at central atom.

$\text{NO}_3^-$ ; No. of  $e^- = 7 + 8 \times 3 + 1 = 32$ , hybridisation of N in  $\text{NO}_3^-$  is  $sp^3$

$\text{CO}_3^{2-}$ ; No. of  $e^- = 6 + 8 \times 3 + 2 = 32$ , hybridisation of C in  $\text{CO}_3^{2-}$  is  $sp^3$

$\text{ClO}_3^-$ ; No. of  $e^- = 17 + 8 \times 3 + 1 = 42$ , hybridisation of Cl in  $\text{ClO}_3^-$  is  $sp^3$

$\text{SO}_3$ ; No. of  $e^- = 16 + 8 \times 3 = 40$ , hybridisation of S in  $\text{SO}_3$  is  $sp^2$

$\therefore \text{NO}_3^-$  and  $\text{CO}_3^{2-}$  are isostructural and isoelectronic.

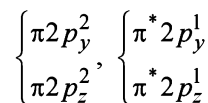
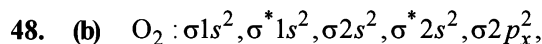

$$\text{Bond order} = \frac{10-6}{2} = 2$$

(two unpaired electrons in antibonding molecular orbital)

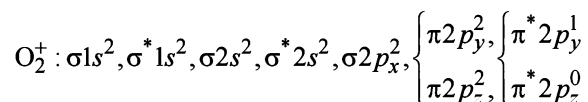

$$\text{Bond order} = \frac{10-5}{2} = 2.5$$

(One unpaired electron in antibonding molecular orbital)

Hence  $\text{O}_2$  as well as  $\text{O}_2^+$  is paramagnetic, and bond

order of  $\text{O}_2^+$  is greater than that of  $\text{O}_2$ .

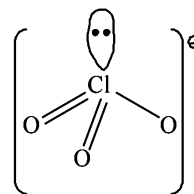
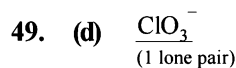

Pyramidal

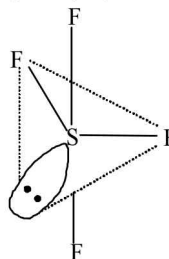
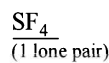

Irregular tetrahedral

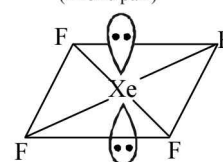
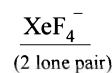

Square planar

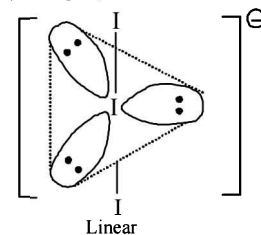
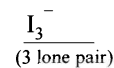

Linear

50. (d) (i) In  $\text{Na}_2\text{O}_2$ , we have  $\text{O}_2^{2-}$  ion. Number of valence electrons of the two oxygen in  $\text{O}_2^{2-}$  ion =  $8 \times 2 + 2 = 18$  which are present as follows

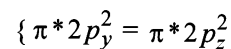
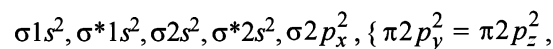

$\therefore$  Number of unpaired electrons = 0, hence,  $\text{O}_2^{2-}$  is diamagnetic.

- (ii) No. of valence electrons of all atoms in  $\text{O}_3 = 6 \times 3 = 18$ . Thus, it also, does not have any unpaired electron, hence it is diamagnetic.
- (iii) No. of valence electrons of all atom in  $\text{N}_2\text{O} = 2 \times 5 + 6 = 16$ . Hence, here also all electrons are paired. So it is diamagnetic.
- (iv) In  $\text{KO}_2$ , we have  $\text{O}_2^-$  No. of valence electrons of all atoms in  $\text{O}_2^- = 2 \times 6 + 1 = 13$ , Thus it has one unpaired electron, hence it is paramagnetic.

51. (a) Molecular electronic configuration of

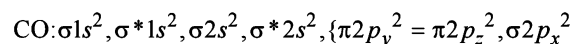

$$\text{Therefore, bond order} = \frac{N_b - N_a}{2} = \frac{10-4}{2} = 3$$

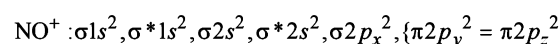

$$\text{Bond order} = \frac{10-4}{2} = 3$$

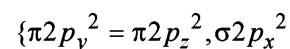
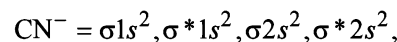

$$\text{Bond order} = \frac{10-4}{2} = 3$$

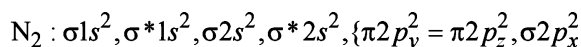

$$\text{Bond order} = \frac{10-4}{2} = 3$$

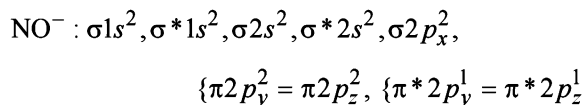

$$\text{Bond order} = \frac{10-6}{2} = 2$$

∴ NO<sup>-</sup> has different bond order from that in CO.

52. (a) Molecular orbital configuration of B<sub>2</sub>(10) as per the condition will be

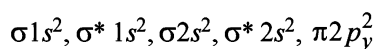

Bond order of B<sub>2</sub> =  $\frac{6-4}{2} = 1$ , B<sub>2</sub> will be diamagnetic.

53. (d) OSF<sub>2</sub>:  $\frac{N}{2} = \frac{6+2}{2} = 4$ . It has 1 lone pair.



(Shape is trigonal pyramidal)

The shapes of SO<sub>3</sub>, BrF<sub>3</sub> and SiO<sub>3</sub><sup>2-</sup> are triangular planar respectively.

54. (b) Ni<sup>+2</sup> + 4Cl<sup>-</sup> → [NiCl<sub>4</sub>]<sup>2-</sup><sub>sp<sup>3</sup></sub>

[NiCl<sub>4</sub>]<sup>2-</sup> = 3d<sup>8</sup> configuration with nickel in +2 oxidation state, Cl<sup>-</sup> being weak field ligand does not compel for pairing of electrons.

So,

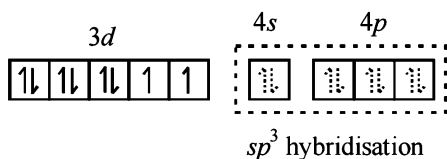

Hence, complex has tetrahedral geometry

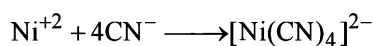
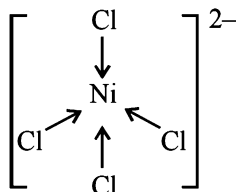

[Ni(CN)<sub>4</sub>]<sup>2-</sup> = 3d<sup>8</sup> configuration with nickel in +2 oxidation state, CN<sup>-</sup> being strong field ligand compels for pairing of electrons.

So,

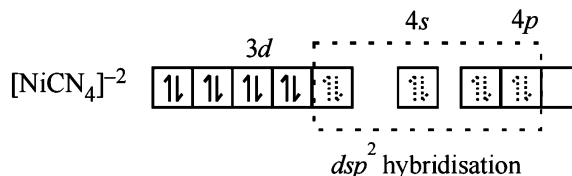

Hence, complex has square planar geometry.

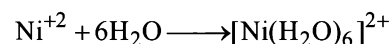
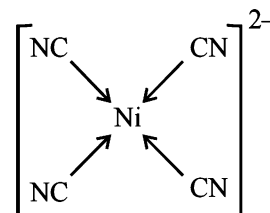

[Ni(H<sub>2</sub>O)<sub>6</sub>] = 3d<sup>8</sup> configuration with nickel in +2 oxidation state. As with 3d<sup>8</sup> configuration two d-orbitals are not available for d<sup>2</sup>sp<sup>3</sup> hybridisation. So, hybridisation of Ni (II) is sp<sup>3</sup>d<sup>2</sup> and Ni (II) with six co-ordination will have octahedral geometry.

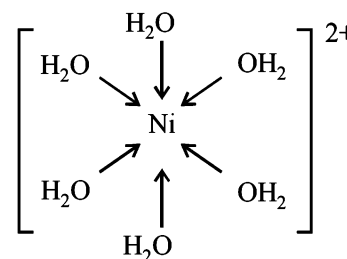

**Note :** With water as ligand, Ni (II) forms octahedral complexes.

55. (c) Be<sub>2</sub> = σ 1s<sup>2</sup> σ\* 1s<sup>2</sup> σ 2s<sup>2</sup> σ\* 2s<sup>2</sup>  
 B<sub>2</sub> = σ 1s<sup>2</sup> σ\* 1s<sup>2</sup> σ 2s<sup>2</sup> σ\* 2s<sup>2</sup> σ<sup>2</sup> p<sub>z</sub><sup>2</sup>  
 C<sub>2</sub> = σ 1s<sup>2</sup> σ\* 1s<sup>2</sup> σ 2s<sup>2</sup> σ\* 2s<sup>2</sup> σ<sup>2</sup> p<sub>z</sub><sup>2</sup> π 2p<sub>x</sub><sup>1</sup> π 2p<sub>y</sub><sup>1</sup>  
 N<sub>2</sub> = σ 1s<sup>2</sup> σ\* 1s<sup>2</sup> σ 2s<sup>2</sup> σ\* 2s<sup>2</sup> σ<sup>2</sup> p<sub>z</sub><sup>2</sup> π 2p<sub>x</sub><sup>2</sup> π 2p<sub>y</sub><sup>2</sup>  
 Thus only C<sub>2</sub> will be paramagnetic
56. (a) Ni<sup>2+</sup> with NH<sub>3</sub> shows CN = 6 forming [Ni(NH<sub>3</sub>)<sub>6</sub>]<sup>2+</sup> (Octahedral)  
 Pt<sup>2+</sup> with NH<sub>3</sub> shows CN = 4 forming [Pt(NH<sub>3</sub>)<sub>4</sub>]<sup>2+</sup> (5d series CMA, square planner)  
 Zn<sup>2+</sup> with NH<sub>3</sub> shows CN = 4 forming [Zn(NH<sub>3</sub>)<sub>4</sub>]<sup>2+</sup> (3d<sup>10</sup> configuration, tetrahedral)

#### D. MCQs with One or More than One Correct

1. (a, c) CO<sub>2</sub>, HgCl<sub>2</sub> and C<sub>2</sub>H<sub>2</sub> have linear structure (sp hybridization), while SnCl<sub>2</sub> is trigonal planar (sp<sup>2</sup> hybridisation). NO<sub>2</sub> has angular structure (V-shape).

2. (b,c,d)  $[O=N=O]^+$ ;  $[N\equiv C-O]^-$ ;  $S=C=S$   
 It can be seen from the structure shown above that  $CS_2$  being  $sp$  hybridized has a linear shape and other two molecules are isoelectronic to  $CS_2$ , so they are also linear.  $SnCl_2$  and  $SO_2$  are  $sp^2$  hybridised and are not linear.
3. (a, c) The outer most shells of C, N & O has 4, 5 and 6 electrons respectively. Thus  $CN^-$  and  $NO^+$  each has 10 electrons to accommodate in the molecular orbitals.  
 So their bond order is same.  $O_2^-$  has 13 and  $CN^+$  has 12 electrons in outermost orbits.
4. (b, c) Alkanes (a) and (d) don't have dipole moment because of symmetry in them.

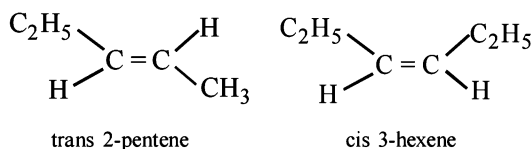

These alkenes are not symmetrical and so they have dipole moment.

5. (b, c)
- | Compound | Number of lone pairs on central atom |
|----------|--------------------------------------|
| $BrF_5$  | → 1                                  |
| $ClF_3$  | → 2                                  |
| $XeF_4$  | → 2                                  |
| $SF_4$   | → 1                                  |
6. (a, c)
- (A) The molecular orbital energy configuration of  $C_2^{2-}$  is  
 $\sigma_{1s}^2, \sigma_{1s}^{*2}, \sigma_{2s}^2, \sigma_{2s}^{*2}, \pi_{2p_x}^2 = \pi_{2p_y}^2, \sigma_{2p_z}^2$   
 In the MO of  $C_2^{2-}$  there is no unpaired electron hence it is diamagnetic
- (B) Bond order of  $O_2^{2+}$  is 3 and  $O_2$  is 2 therefore bond length of  $O_2$  is greater than  $O_2^{2+}$
- (C) The molecular orbital energy configuration of  $N_2^+$  is  
 $\sigma_{1s}^2, \sigma_{1s}^{*2}, \sigma_{2s}^2, \sigma_{2s}^{*2}, \pi_{2p_x}^2 = \pi_{2p_y}^2, \sigma_{2p_z}^1$   
 Bond order of  $N_2^+ = \frac{1}{2}(9 - 4) = 2.5$   
 The molecular orbital energy configuration of  $N_2^-$  is  
 $\sigma_{1s}^2, \sigma_{1s}^{*2}, \sigma_{2s}^2, \sigma_{2s}^{*2}, \pi_{2p_x}^2 = \pi_{2p_y}^2, \sigma_{2p_z}^2, \pi_{2p_x}^{*1} = \pi_{2p_y}^{*1}$   
 Bond order of  $N_2^- = \frac{1}{2}(10 - 5) = 2.5$
- (D)  $He_2^+$  has less energy in comparison to two isolated He atoms because some energy is released during the formation of  $He_2^+$  from 2 He atoms.

### E. Subjective Problems

1.  $H_2O$  molecules are held together by hydrogen bonding which is stronger force of attraction but  $H_2S$  molecules are held together by vander waals forces of attraction, which are weaker forces. As a result water molecules come closer and exist in liquid state.

2. Lewis dot structure Neutral molecule

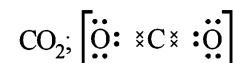
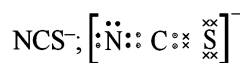
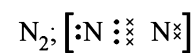
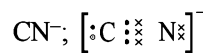
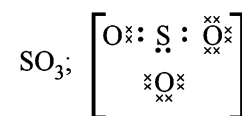
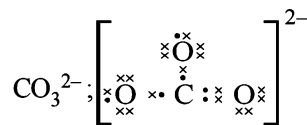
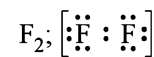
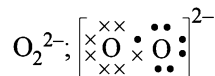

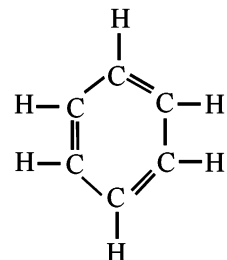
3.  ∴ It has 12σ and 3π bonds.  
 (6σ C-C bonds and 6σ C-H bonds)

4.  $O_3$ ;  $O=O \rightarrow O$ ;  $\cdot \cdot \ddot{O} :: \ddot{O} :: \ddot{O} \cdot \cdot$   
 $COCl_2$ ;  $O=C-Cl$ ;  $\cdot \cdot \ddot{O} :: \times \times C \times \times \ddot{Cl} \cdot \cdot$

5. (i) Increasing order of bond dissociation energy.  
 $F_2 < Cl_2 < O_2 < N_2$   
**NOTE** : Fluorine-fluorine bond energy is less than the Cl-Cl because of larger repulsion between the non-bonded electrons of the two smaller fluorine atoms (chlorine atoms are larger in size; hence their lone pair of electrons exert less repulsion than fluorine). Oxygen having two pairs of lone pair of electrons on each atom exert less repulsion than that of chlorine or fluorine each having three lone pairs of electrons. Nitrogen having only one lone pair of electrons exert minimum repulsion, hence it is the most stable.
- (ii) H-bonding is an electrostatic attractive force between covalently bonded hydrogen atom of one molecule and an electronegative atom (F, O, N). Further, higher the electronegativity and smaller the size of the atom, the stronger is the hydrogen bond.  
**NOTE** : Although Cl has the same electronegativity as nitrogen, it does not form effective hydrogen bonds. This is because of its larger size than that of N with the result its electrostatic attractions are weak. Similarly, sulphur forms a very weak hydrogen bond due to its low electronegativity, although oxygen present in the same group forms a strong hydrogen bond.  
 Hence the order is  $S < Cl < N < O < F$
- (iii) In  $KO_2$ ,  $O_2$  is present as  $O_2^-$ , while in  $O_2^+(AsF_4)$ ,  $O_2$  is present as  $O_2^+$ . Write down the MO configuration of  $O_2$ ,  $O_2^-$  and  $O_2^+$ .

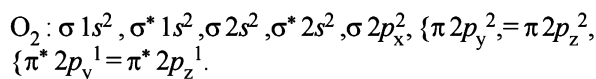

$$\text{Thus the bond order} = \frac{10-6}{2} = 2$$

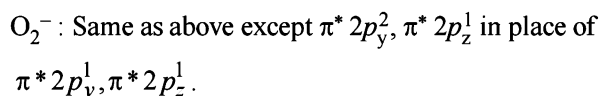

$$\text{Thus the bond order in } O_2^- = \frac{10-7}{2} = 1.5$$

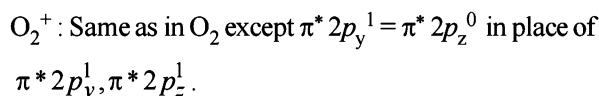

$$\therefore \text{Bond order in } O_2^+ = \frac{10-5}{2} = 2.5$$

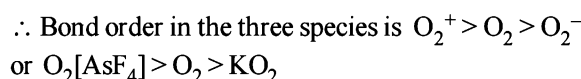

6. Dipole moment,  $\mu = e \times d$  coulombs metre

$$\text{For KCl } d = 2.6 \times 10^{-10} \text{ m}$$

For complete separation of unit charge (electronic charge)  $(e) = 1.602 \times 10^{-19} \text{ C}$

$$\text{Hence } \mu = 1.602 \times 10^{-19} \times 2.6 \times 10^{-10} = 4.1652 \times 10^{-29} \text{ Cm}$$

$$\mu_{KCl} = 3.336 \times 10^{-29} \text{ Coulomb meter (given)}$$

$$\therefore \% \text{ Ionic character of KCl} = \frac{3.336 \times 10^{-29}}{4.1652 \times 10^{-29}} \times 100 = 80.09\%$$

7. The structure of  $OF_2$  is similar to  $H_2O$  and involves  $sp^3$  hybridization on O atom. The bond angle in  $F-O-F$  is not exactly  $109^\circ 28'$ , but distorted ( $103^\circ$ ) due to presence of lone pair of electrons on O as well as F leading to V shape or tetrahedral positions with two positions occupied by lone pair of electrons of the molecule.

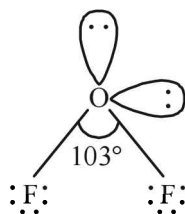

Oxidation number of F = -1

$\therefore$  Oxidation number of O = +2

8. Magnetic moment ( $\mu$ ) =  $\sqrt{n(n+2)}$  BM

where  $n \rightarrow$  number of unpaired electrons

$$\mu = 1.73 \text{ BM for vanadium ion}$$

$$1.73 \text{ BM} = \sqrt{n(n+2)} \quad \text{So, } (1.73)^2 = n(n+2)$$

$$3.0 = n^2 + 2n \quad \text{or } n^2 + 2n - 3 = 0$$

$$n^2 + 3n - n - 3 = 0 \quad \therefore n(n+3) - 1(n+3) = 0$$

$$(n-1)(n+3) = 0 \quad \text{Correct value of } n = 1$$

Thus no. of unpaired electrons in vanadium ion = 1

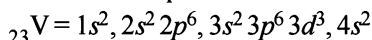

It will have one unpaired electron if it will lose two electrons from 4s and two from 3d.

$\therefore$  Vanadium (IV) has one unpaired electron.

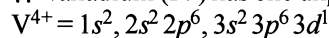

9. In  $H_2S$ , no. of hybrid orbitals =  $\frac{1}{2}(6+2-0+0) = 4$

Hence here sulphur is  $sp^3$  hybridised, so

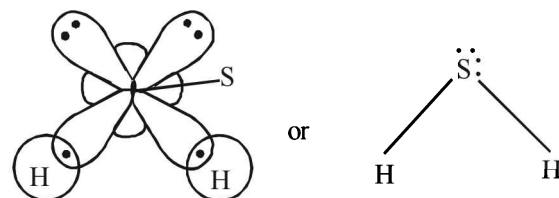
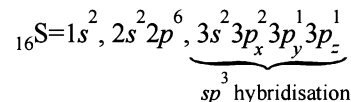

**NOTE :** Due to repulsion between  $lp-lp$ ; the geometry of  $H_2S$  is distorted from tetrahedral to V-shape.

In  $PCl_3$ , no. of hybrid orbitals =  $\frac{1}{2}[5+3-0+0] = 4$

Hence, here P shows  $sp^3$  - hybridisation

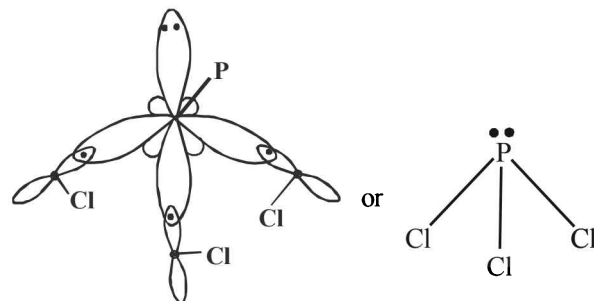
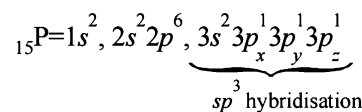

Thus due to repulsion between  $lp-bp$ , geometry is distorted from tetrahedral to pyramidal.

10. MO configuration of  $O_2$  :

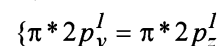
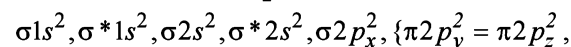

$$\text{Bond order} = \frac{1}{2}(10-6) = 2$$

Since  $O_2$  molecule has two unpaired electrons, it is paramagnetic.

- 11.

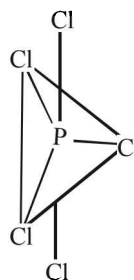

$PCl_5 : sp^3d$  Trigonal bipyramidal

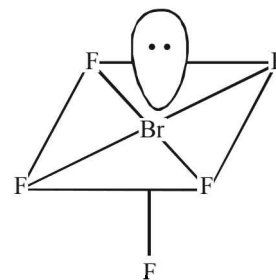

$BrF_5 : sp^3d^2$   
Square pyramidal

12. First determine the total number of electron pairs around the central atom.

$$\text{XeF}_4 = \frac{N}{2} = \frac{8+4}{2} = 6$$

Thus in  $\text{XeF}_4$ , Xe is  $sp^3d^2$  hybridised. The structure of the molecule is octahedral and shape is square planer with two lone pair of electrons.

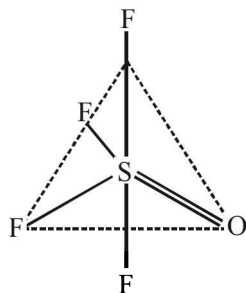
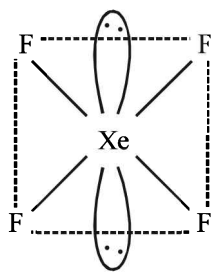

$$\text{For OSF}_4: \frac{N}{2} = \frac{6+4}{2} = 5$$

Thus the central atom (S) is  $sp^3d$  hybridised leading to trigonal bipyramidal structure with no lone pair of electrons.

### F. Match the Following

1. (c) P.

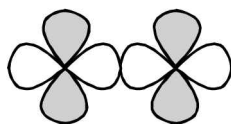

d - d ( $\sigma$  bonding)

- Q.

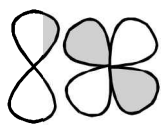

p - d ( $\pi$  bonding)

- R.

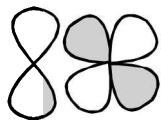

p - d ( $\pi$  antibonding)

- S.

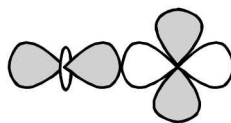

d - d ( $\sigma$  antibonding)

### H. Assertion & Reason Type Questions

- (a) Both assertion and reason are correct. The reason explains the assertion as the central O-atom cannot have more than 8 electrons (octet).
- (c)  $\text{LiCl}$  is a covalent compound since due to the large size of the anion ( $\text{Cl}^-$ ) its effective nuclear charge lessens and its valence shells are held less tightly towards its nucleus. Here, assertion is correct but reason is incorrect.

### I. Integer Value Correct Type

1. (0) According to VSEPR theory, number of electron pairs around central atom (Br) are 6.

$$\frac{N}{2} = \frac{7+5}{2} = 6. \text{ (Five are bond pairs and one is lone pair)}$$

Its geometry is octahedral but due to lone pair - bond pair repulsion, the four fluorine atoms at corner are forced towards the upper fluorine atom thus reducing F-Br-F angle from  $90^\circ$  to  $84.8^\circ$ .

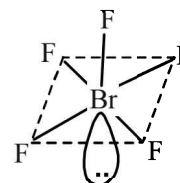

2. (6) Structure of melamine is as follows :

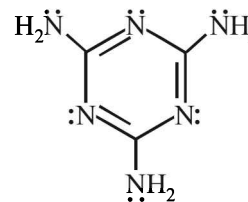

Total no. of lone pairs of electron is '6'.

3. (4)

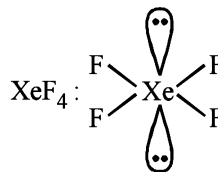

Square planar ( $sp^3d^2$ )

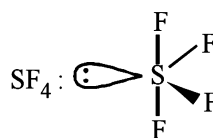

See-saw ( $sp^3d$ )

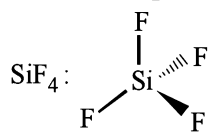

Tetrahedral ( $sp^3$ )

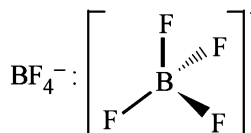

Tetrahedral ( $sp^3$ )

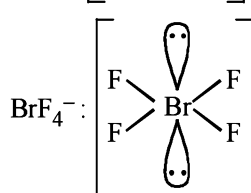

Square planar ( $sp^3d^2$ )

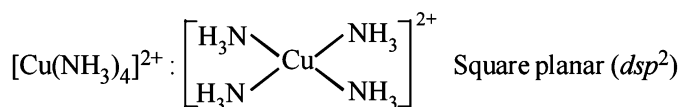

Square planar ( $dsp^2$ )

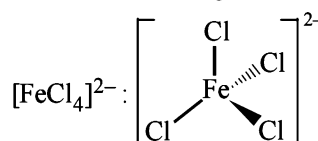

Tetrahedral ( $sp^3$ )

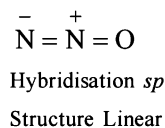
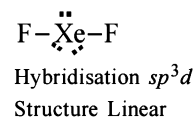
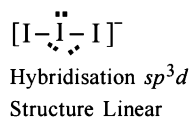
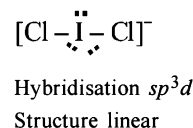
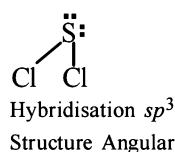
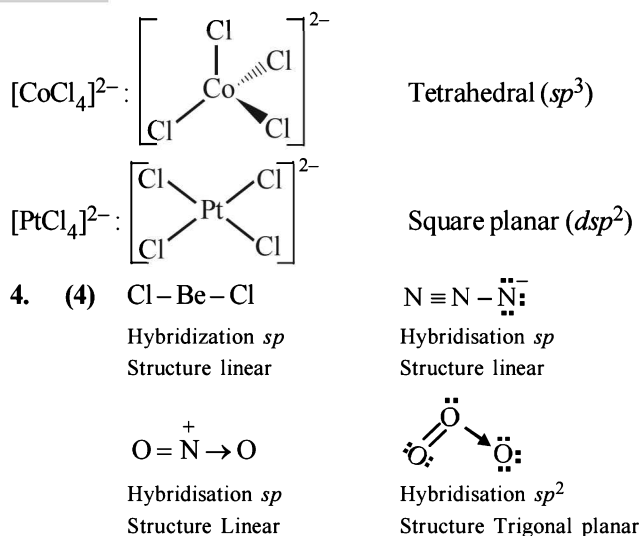

Only  $\text{BeCl}_2$ ,  $\text{N}_3^-$ ,  $\text{N}_2\text{O}$  and  $\text{NO}_2$  are linear with  $sp$ -hybridisation.

## Section-B JEE Main/ AIEEE

1. (a) In  $\text{NH}_3$  and  $\text{BF}_4^-$  the hybridisation is  $sp^3$  and the bond angle is almost  $109^\circ 28'$ .

2. (b)  $\text{O}_2^+(15) = \text{KK} \sigma 2s^2, \sigma^* 2s^2, \sigma 2p_x^2, \{\pi 2p_y^2 = \pi 2p_z^2\}, \{\pi^* 2p_y^1 = \pi^* 2p_z^0\}$

$$\text{Bond order} = \frac{1}{2}(8-3) = \frac{5}{2} = 2.5$$

$\text{O}_2(16) = \text{KK} \sigma 2s^2, \sigma^* 2s^2, \sigma 2p_x^2, \{\pi 2p_y^2 = \pi 2p_z^2\}, \{\pi^* 2p_y^1 = \pi^* 2p_z^1\}$

$$\text{Bond order} = \frac{1}{2}(8-4) = 2$$

$\text{O}_2^-(17) = \text{KK} \sigma 2s^2, \sigma^* 2s^2, \sigma 2p_x^2, \{\pi 2p_y^2 = \pi 2p_z^2\}, \{\pi^* 2p_y^2 = \pi^* 2p_z^1\}$

$$\text{Bond order} = \frac{1}{2}(8-5) = 1.5$$

$\text{O}_2^{2-}(18) = \text{KK} \sigma 2s^2, \sigma^* 2s^2, \sigma 2p_x^2, \{\pi 2p_y^2 = \pi 2p_z^2\}, \{\pi^* 2p_y^2 = \pi^* 2p_z^2\}$

$$\text{Bond order} = \frac{1}{2}(8-6) = 1$$

**NOTE** : As we know that as the bond order decreases, stability also decreases and hence the bond strength also decreases. Hence the correct order of their increasing bond strength is

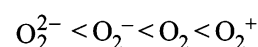

3. (a) **TIPS/Formulas** :

$$\text{Hybridisation} = \frac{1}{2} \left[ \left( \begin{array}{l} \text{No. of electrons} \\ \text{in valence} \\ \text{shell of atom} \end{array} \right) + \right.$$

$$\left. \left( \begin{array}{l} \text{No. of monovalent} \\ \text{atoms around it} \end{array} \right) - \left( \begin{array}{l} \text{charge on} \\ \text{cation} \end{array} \right) + \left( \begin{array}{l} \text{charge on} \\ \text{anion} \end{array} \right) \right]$$

(a) For  $\text{AlH}_3$ ,

$$\text{Hybridisation of Al atom} = \frac{1}{2}[3+3-0+0] = 3 = sp^2$$

For  $\text{AlH}_4^-$ ,

$$\text{Hybridisation of Al atom} = \frac{1}{2}[3+4-0+1] = 4 = sp^3$$

(b) For  $\text{H}_2\text{O}$ ,

$$\text{Hybridisation of O atom} = \frac{1}{2}[6+2-0+0] = 4 = sp^3$$

$$\text{For } \text{H}_3\text{O}^+, \text{Hybridisation of O atom} = \frac{1}{2}[6+3-1+0]$$

$$= 4 = sp^3$$

(c) For  $\text{NH}_3$

$$\text{Hybridisation of N atom} = \frac{1}{2}[5+3-0+0] = 4 = sp^3$$

$$\text{For } \text{NH}_4^+, \text{Hybridisation of N atom} = \frac{1}{2}[5+4-1+0]$$

$$= 4 = sp^3$$

Thus hybridisation changes only in option (a).

4. (c) In ether, there is no H-bonding while alcohols have intermolecular H-bonding
5. (b) Both  $\text{NO}_2$  and  $\text{O}_3$  have angular shape and hence will have net dipole moment.
6. (b) In  $\text{H}_2\text{S}$ , due to low electronegativity of sulphur the L.P. - L.P. repulsion is more than B.P. - B.P. repulsion and hence the bond angle is minimum.

	$\text{SO}_2$	$\text{H}_2\text{O}$	$\text{H}_2\text{S}$	$\text{NH}_3$
Bond angle	$119.5^\circ$	$104.5^\circ$	$92.5^\circ$	$106.5^\circ$



7. (a) Both  $\text{XeF}_2$  and  $\text{CO}_2$  have a linear structure.



8. (a) The order of bond angles

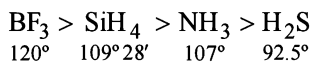

9. (b) Now since bond order of  $\text{NO}^+$  given (3) is higher than that of  $\text{NO}$  (2.5). Thus bond length of  $\text{NO}^+$  will be shorter.

10. (b)

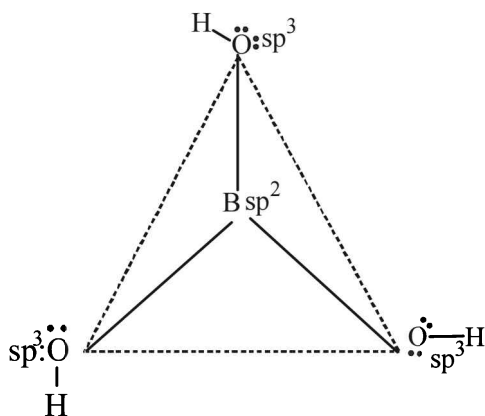

11. (a)  $\text{XeF}_4$  ( $\text{sp}^3\text{d}^2$  square planar),

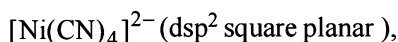

12. (d)

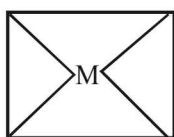

$\text{dsp}^2$  hybridisation  
Number of  $90^\circ$  angle  
between bonds = 4

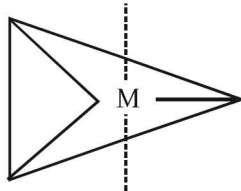

$\text{sp}^3\text{d}$  or  $\text{dsp}^3$  hybridisation  
Number of  $90^\circ$  angle  
between bonds = 6

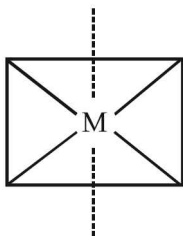

$\text{sp}^3\text{d}^2$  hybridisation  
Number of  $90^\circ$  angle  
between bonds = 12

13. (a) The value of lattice energy depends on the charges present on the two ions and the distance between them.

14. (c) The distribution of electrons in MOs is as follows :

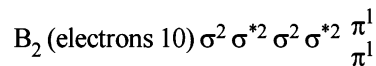
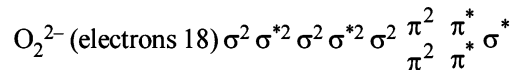
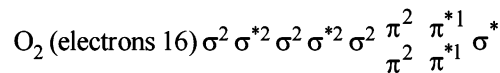
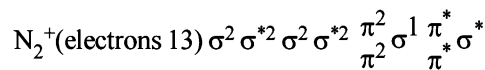

Only  $\text{O}_2^{2-}$  does not contain any unpaired electron.

15. (d) In  $\text{SF}_4$  the hybridisation is  $\text{sp}^3\text{d}$  and the shape of molecule is

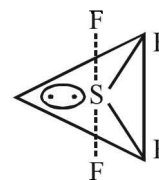

16. (b) The bond angle decreases on moving down the group due to decrease in bond pair-bond pair repulsion.

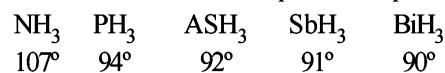

**NOTE :** This can also be explained by the fact that as the size of central atom increases  $\text{sp}^3$  hybrid orbital becomes more distinct with increasing size of central atom i.e. pure p-orbitals are utilized in M-H bonding

17. (b) Diamagnetic species have no unpaired electrons

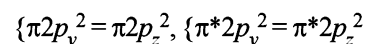
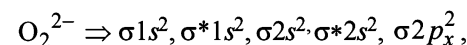

Whereas paramagnetic species has one or more unpaired electrons as in

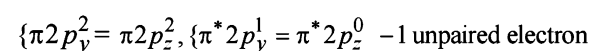
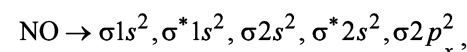
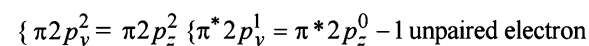
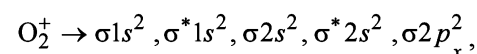
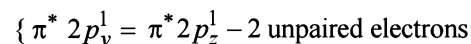
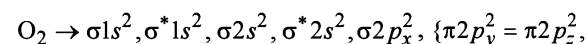

18. (d) Smaller the size and higher the charge more will be polarising power of cation. Since the order of the size of cation is  $\text{K}^+ > \text{Ca}^{2+} > \text{Mg}^{2+} > \text{Be}^{2+}$ . So the correct order of polarising power is  $\text{K}^+ < \text{Ca}^{2+} < \text{Mg}^{2+} < \text{Be}^{2+}$

19. (c) (a)  $N_2$ : bond order 3, paramagnetic  
 $N_2^-$ : bond order, 2.5, paramagnetic  
 (b)  $C_2$ : bond order 2, diamagnetic  
 $C_2^+$ : bond order 1.5, paramagnetic  
 (c)  $NO$ : bond order 2.5, paramagnetic  
 $NO^+$ : bond order 3, diamagnetic  
 (d)  $O_2$ : bond order 2, paramagnetic  
 $O_2^+$ : bond order 2.5, paramagnetic

20. (c) **NOTE**: Greater the difference between electronegativity of bonded atoms, stronger will be bond. Since F is most electronegative hence F – H ..... F is the strongest bond.

21. (a) For any species to have same bond order we can expect them to have same number of electrons. Calculating the number of electrons in various species.

$$O_2^- (8+8+1=17); CN^- (6+7+1=14)$$

$$NO^+ (7+8-1=14); CN^+ (6+7-1=12)$$

We find  $CN^-$  and  $NO^+$  both have 14 electrons so they have same bond order. Correct answer is (a).

22. (b) **NOTE**: The delocalised  $p\pi - p\pi$  bonding between filled  $p$ -orbital of F and vacant  $p$ -orbital of B leads to shortening of B–F bond length which results in higher bond dissociation energy of the B–F bond.

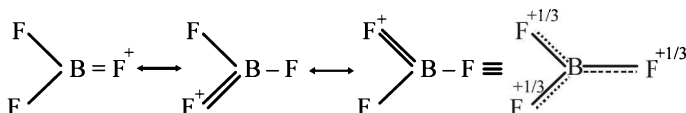
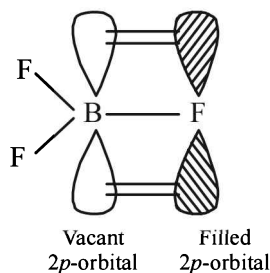

23. (d) Bond order

$$= \frac{\text{No. of bonding electrons} - \text{No. of antibonding electrons}}{2}$$

$$\text{Bond order in } O_2^+ = \frac{10-5}{2} = 2.5$$

$$\text{Bond order in } O_2^- = \frac{10-7}{2} = 1.5$$

$$\text{Bond order in } O_2^{2-} = \frac{10-8}{2} = 1$$

$$\text{Bond order in } O_2^{2+} = \frac{10-4}{2} = 3$$

$$\text{Since Bond order} \propto \frac{1}{\text{Bond length}}$$

$\therefore$  Bond length is shortest in  $O_2^{2+}$ .

24. (c) The proportion of covalent character in an ionic bond is decided by polarisability of the metal cation as well as the electronegativity of both elements involved in bonding. Polarisability is further decided by the density of positive charge on the metal cation.  $AlCl_3$  is considered to show maximum covalent character among the given compounds. This is because  $Al^{3+}$  bears 3 unit of positive charge and shows strong tendency to distort the electron cloud, thus the covalent character in Al-Cl bond dramatically increases.

25. (b) The formula to find the hybridisation of central atom is

$$Z = \frac{1}{2} [\text{Number of valence electrons on central atom} +$$

No. of monovalent atom attached to it + negative charge if any – positive charge if any]

$$\text{For } NO_3^-, Z = \frac{1}{2} [5+0+1-0] = 3$$

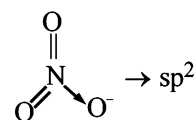

$$\text{For } NO_2^+, Z = \frac{1}{2} [5+0+0-1] = 2$$

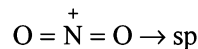

$$\text{For } NH_4^+, Z = \frac{1}{2} [5+4+0-1] = 4$$

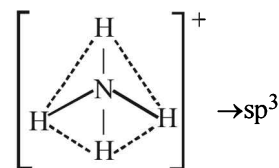

26. (d) Pentagonal bipyramidal shape.

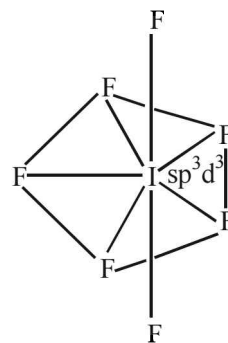

27. (b) Compounds involved in chelation become non-polar. Consequently such compounds are soluble in non-polar solvents like ether, benzene etc. and are only sparingly soluble in water whereas meta and para isomers are more soluble in water & less soluble in non-polar solvents.

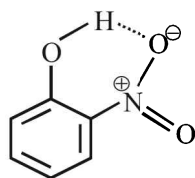

intra-molecular H-bonding

28. (c)  $\text{PF}_5$  trigonal bipyramidal

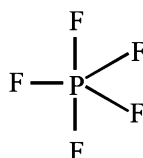
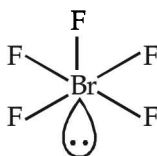
 $\text{BrF}_5$  square pyramidal (distorted)

29. (a, b) The molecular orbital structures of  $\text{C}_2$  and  $\text{N}_2$  are

$$\text{N}_2 = \sigma 1s^2 \sigma^* 1s^2 \sigma 2s^2 \sigma^* 2s^2 \sigma 2p_x^2 \pi 2p_y^2 \pi 2p_z^2$$

$$\text{C}_2 = \sigma 1s^2 \sigma^* 1s^2 \sigma 2s^2 \sigma^* 2s^2 \pi 2p_y^2 \pi 2p_z^2$$

both  $\text{N}_2$  and  $\text{C}_2$  have paired electrons in its molecular orbital hence are diamagnetic.

30. (a)

$$\left. \begin{array}{l} \text{ONCl} = 8 + 7 + 17 = 32e^- \\ \text{ONO}^- = 8 + 7 + 8 + 1 = 24e^- \end{array} \right\} \text{not isoelectronic}$$

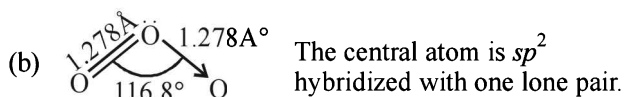

- (c) It is a pale blue gas. At  $-249.7^\circ$ , it forms violet black crystals.

- (d) It is diamagnetic in nature due to presence of paired electrons.

31. (c)  $\text{H}_2^{2+} = \sigma 1s^0 \sigma^* 1s^0$

$$\text{bond order for } \text{H}_2^{2+} = \frac{1}{2}(0-0) = 0$$

$$\text{He}_2 = \sigma 1s^2 \sigma^* 1s^2$$

$$\text{bond order for } \text{He}_2 = \frac{1}{2}(2-2) = 0$$

so both  $\text{H}_2^{2+}$  and  $\text{He}_2$  does not exist

32. (b)  $\text{Li}_2 = \sigma 1s^2 \sigma^* 1s^2 \sigma 2s^2$ ,  $\therefore$  Bond order =  $\frac{1}{2}(4-2) = 1$

$$\text{Li}_2^+ = \sigma 1s^2 \sigma^* 1s^2 \sigma 2s^1, \text{ B.O.} = \frac{1}{2}(3-2) = 0.5$$

$$\text{Li}_2^- = \sigma 1s^2 \sigma^* 1s^2 \sigma 2s^2 \sigma^* 2s^1, \text{ B.O.} = \frac{1}{2}(4-3) = 0.5$$

The bond order of  $\text{Li}_2^+$  and  $\text{Li}_2^-$  is same but  $\text{Li}_2^+$  is more stable than  $\text{Li}_2^-$  because  $\text{Li}_2^+$  is smaller in size and has 2 electrons in Anti bonding orbital whereas  $\text{Li}_2^-$  has 3 electrons in Anti bonding orbital. hence  $\text{Li}_2^+$  is more stable than  $\text{Li}_2^-$

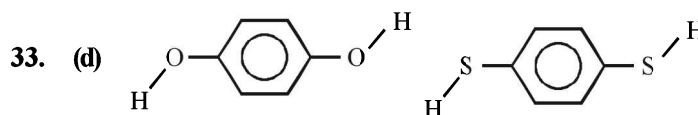

In both the molecules the bond moments are not canceling with each other and hence the molecules has a resultant dipole and hence the molecule is polar.

34. (c) Hybridization (H) =  $\frac{1}{2}$  [no. of valence electrons of central atom + no. of Monovalent atoms attached to it + (-ve charge if any) - (+ve charge if any)]

$$\text{NO}_2^+ = \frac{1}{2}[5+0+0-1] = 2 \text{ i.e. } sp \text{ hybridisation}$$

$$\text{NO}_2 = \frac{1}{2}[5+0+1-0] = 3 \text{ i.e. } sp^2 \text{ hybridisation}$$

$$\text{NO}_3^- = \frac{1}{2}[5+0+1-0] = 3 \text{ i.e. } sp^2 \text{ hybridisation}$$

The lewis structure of  $\text{NO}_2$  shows a bent molecular geometry with trigonal planar electron pair geometry hence the hybridization will be  $sp^2$

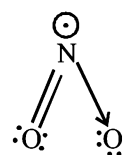

## Section-A : JEE Advanced/ IIT-JEE

- A** 1. 900      2. R      3. inversely, time      4. 0.25      5. 1 : 16
- B** 1. F      2. F      3. F      4. F
- C** 1. (a)      2. (b)      3. (a)      4. (b)      5. (b)      6. (d)      7. (a)  
 8. (c)      9. (b)      10. (c)      11. (b)      12. (a)      13. (d)      14. (a)  
 15. (a)      16. (c)      17. (c)      18. (b)      19. (b)      20. (b)      21. (c)  
 22. (c)      23. (b)      24. (c)      25. (d)      26. (c)      27. (b)      28. (c)  
 29. (c)      30. (b)      31. (a)      32. (b)      33. (b)      34. (c)      35. (d)
- D** 1. (b)      2. (a, b)      3. (d)      4. (c)      5. (b)      6. (a, c)      7. (a, b, c, d)      8. (c)
- E** 1. 3.42 g/litre      2. 39.13      3. 85.2 cm      4. 3 : 2  
 5. 2.197 atm      6.  $6.21 \times 10^{-21}$  joules/molecule      7.  $2.7 \times 10^{10}$  molecules      8. 1 : 3  
 9.  $3.9 \times 10^4$  cm sec<sup>-1</sup>      10. 10      11. 1682.5 K, 2143.4 K      12. 5.23 L  
 13. 1033      14. 0.0043, 0.221 atm      15. 494.16 m/s, 274.13 K, 405.2 m/sec      16. 8 : 1  
 17. 2.463 m<sup>3</sup>, 1.478 atm      18. 33.75% and 66.25%      19. 13.7%  
 20. CH<sub>4</sub>-20%, CO-50%, He-30%      21. 123      22. 4.53 g/litre      23. 6.46 atm litre<sup>2</sup> mol<sup>-2</sup>  
 24. 0.4      25. XeF<sub>6</sub>      26. 100 K, 0.82 litre      27. 0.9922 atm      28. 1.253 atm L<sup>2</sup> mol<sup>-2</sup>  
 29. (a) (i) 18.09, (ii) 41.025 L, (iii) 1.224, (b)  $2.07 \times 10^{-20}$       30. 434 ms<sup>-1</sup>      31. RT
- F** 1. (A) - (p, s); (B) - (r); (C) - (p, q); (D) - (r);
- G** 1. (c)      2. (d)
- H** 1. (a)      2. (a)
- I** 1. 4      2. 7      3. 4

## Section-B : JEE Main/ AIEEE

1. (c)      2. (c)      3. (d)      4. (b)      5. (a)      6. (a)      7. (c)  
 8. (d)      9. (d)      10. (c)      11. (c)      12. (b)      13. (b)      14. (b)      15. (a)

## Section-A JEE Advanced/ IIT-JEE

## A. Fill in the Blanks

1. **900**; Energy of one mole of an ideal monoatomic gas =  $\frac{3}{2} RT$   
 $R = 8.314 \text{ J K}^{-1} \text{ mole}^{-1} = 1.99 \text{ cal K}^{-1} \text{ mole}^{-1}$   
 $T = 27^\circ\text{C} = 273 + 27 = 300 \text{ K}$   
 $\Rightarrow E = \frac{3}{2} \times 1.99 \times 300 = 900 \text{ cal}$
2. **R** [ $\because C_p - C_v = R$ ]
3. **Inversely, time**;  $\left[ \frac{r_1}{r_2} = \sqrt{\frac{d_2}{d_1}} = \frac{t_2}{t_1} = \sqrt{\frac{M_2}{M_1}} \right]$ .
4. **0.25**; ( $\because 5.6 \text{ l} \equiv \frac{1}{4}$  mole of an ideal gas)  
 Using ideal gas equation  
 $PV = nRT = \frac{1}{4} RT = 0.25 RT$
5. **1 : 16**;  $\frac{\text{K.E.}_{\text{O}_2}}{\text{K.E.}_{\text{H}_2}} = \frac{(3/2)n_{\text{O}_2} RT}{(3/2)n_{\text{H}_2} RT} = \frac{n_{\text{O}_2}}{n_{\text{H}_2}} = \frac{8/32}{8/2} = \frac{1}{16}$

## B. True / False

- False** : K.E. =  $\frac{3}{2} KT$ , and cannot be zero at  $0^\circ\text{C}$  or  $273\text{ K}$ .
- False** : The pressure exerted by the gas is the result of collisions of the molecules on the walls of the container.
- False** : The constant 'a' reflects the intermolecular attraction between gaseous molecules. The constant 'b' reflects the actual volume of one mole of gaseous molecules.
- False** : An ideal gas cannot be liquefied as there exists no intermolecular attraction between molecules.

## C. MCQs with One Correct Answer

1. (a) TIPS/Formulae :

$$\text{Mole fraction of O}_2 = \frac{\text{Moles of O}_2}{\text{Total moles}}$$

$$\text{Partial pressure of O}_2 = \text{Mole fraction of O}_2$$

$$\text{Mole fraction of O}_2 = \frac{\frac{W}{32}}{\frac{W}{16} + \frac{W}{32}} = \frac{1}{3}$$

- (b) The temperature at which a real gas behaves like an ideal gas is called Boyle's temperature or Boyle's point.
- (a)  $U_{\text{rms}} : U_{\text{av}} = \sqrt{\frac{3RT}{M}} : \sqrt{\frac{8RT}{\pi M}}$  or  $\sqrt{3} : \sqrt{\frac{8}{\pi}} = 1.086 : 1$
- (b) Average kinetic energy depends only on temperature and does not depend upon the nature of the gas. ( $\because$  K.E. =  $\frac{3}{2} KT$ )
- (b) Pressure exerted by hydrogen will be proportional to its mole fraction.

$$\text{Mole fraction of H}_2 = \frac{\frac{w}{2}}{\frac{w}{16} + \frac{w}{2}} = \frac{8}{9}$$

6. (d)  $\frac{r_1}{r_2} = \sqrt{\frac{d_2}{d_1}} = \sqrt{\frac{M_2}{M_1}}$

7. (a)  $U_{\text{av}} = \sqrt{\frac{8RT}{\pi M}}$  ;  $\left\{ \begin{array}{l} T_1 = 27 + 273 = 300\text{ K} \\ T_2 = 927 + 273 = 1200\text{ K} \end{array} \right\}$

$$\frac{U_{\text{av}_1}}{U_{\text{av}_2}} = \sqrt{\frac{T_1}{T_2}} \text{ or } \frac{0.3}{U_{\text{av}_2}} = \sqrt{\frac{300}{1200}} \text{ or } \frac{0.3}{U_{\text{av}_2}} = \sqrt{\frac{1}{4}}$$

or  $U_{\text{av}_2} = 0.6\text{ m/sec}$ .

8. (c)  $\left(P + \frac{a}{V^2}\right) (V - b) = RT$ ; Here  $\left(P + \frac{a}{V^2}\right)$  represents

the intermolecular forces.

9. (b) TIPS/Formulae :

$$\text{Rate of diffusion} \propto \sqrt{\frac{1}{\text{Molecular mass}}}$$

 $\therefore$  Molecular mass of  $\text{HCl} >$  molecular mass of  $\text{NH}_3$  $\therefore$   $\text{HCl}$  diffuses at slower rate and white ammonium chloride is first formed near  $\text{HCl}$  bottle.

- (c) 'a' is directly related to forces of attraction. Hence greater the value of 'a', more easily the gas is liquified.
- (b) TIPS/Formulae :

$$d = \frac{PM}{RT}$$

It means density of gas is directly proportional to pressure and inversely proportional to temperature.

Density of neon will be maximum at highest pressure and lowest temperature.

 $\therefore$  (b) is correct answer.

12. (a)  $\frac{r_{\text{CH}_4}}{r_x} = 2 = \sqrt{\frac{M_x}{M_{\text{CH}_4}}} = \sqrt{\frac{M_x}{16}}$ , or  $M_x = 64$

13. (d) Pressure exerted by the gas,  $P = \frac{1}{3} \frac{mnu^2}{V}$  ... (1)

Here,  $u$  = root mean square velocity $m$  = mass of a molecule,  $n$  = No. of molecules of the gas

Hence (a) &amp; (b) are clearly wrong.

Again  $u^2 = \frac{3RT}{M}$  [explained from (1)]

Here,  $M$  = Molecular wt. of the gas;

Hence (c) is wrong

Further, Average K.E. =  $\frac{3}{2} KT$ ; Hence (d) is true.

14. (a) Due to increase in the temperature, the kinetic energy of the gas molecules increases resulting in an increase in average molecular speed. The molecules are bombarded to the walls of the container with a greater velocity resulting in an increase in pressure.

15. (a) The mean free path,  $\lambda = \frac{1}{\sqrt{2} \pi a^2 N}$

or  $\lambda \propto \frac{1}{a^2}$ , where  $a$  = molecular diameter $\therefore$  Smaller the molecular diameter, longer the mean free path. Hence  $\text{H}_2$  is the answer.

16. (c) NOTE : The value of 'a' indicates the magnitude of attractive forces between gas molecules.

Value of 'a'  $\propto$  size of molecule. $\therefore$  inert gas will have minimum value of 'a' followed by  $\text{H}_2\text{O}$ ,  $\text{C}_6\text{H}_6$  and  $\text{C}_6\text{H}_5\text{CH}_3$ 

17. (c) The expression of root mean square speed is

$$U_{\text{rms}} = \sqrt{\frac{3RT}{M}}$$

Hence,

$$\frac{U_{\text{rms}}(\text{H}_2)}{U_{\text{rms}}(\text{O}_2)} = \left[ \frac{3R(50\text{K})/(2\text{g mol}^{-1})}{3R(800\text{K})/(32\text{g mol}^{-1})} \right]^{1/2} = 1$$

18. (b) Under identical conditions,  $\frac{r_1}{r_2} = \sqrt{\frac{M_2}{M_1}}$

As rate of diffusion is also inversely proportional to

time, we will have,  $\frac{t_2}{t_1} = \sqrt{\frac{M_2}{M_1}}$

(a) Thus, For He,  $t_2 = \sqrt{\frac{4}{2}}(5\text{s}) = 5\sqrt{2}\text{s} \neq 10\text{s}$ ;

(b) For O<sub>2</sub>,  $t_2 = \sqrt{\frac{32}{2}}(5\text{s}) = 20\text{s}$

(c) For CO,  $t_2 = \sqrt{\frac{28}{2}}(5\text{s}) \neq 25\text{s}$ ;

(d) For CO<sub>2</sub>,  $t_2 = \sqrt{\frac{44}{2}}(5\text{s}) \neq 55\text{s}$

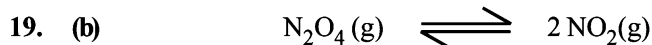

At start	100/92 mol	0
	= 1.08 mol	
At equilibrium	80/92 mol	20/46 mol
	= 0.86 mol	= 0.43 mol

According to ideal gas equation, at two conditions

At 300 K;  $P_0V = n_0RT_0$   
 $1 \times V = 1.08 \times R \times 300 \quad \dots \text{(i)}$

At 600 K;  $P_1V = n_1RT_1$   
 $P_1 \times V = (0.86 + 0.43) \times R \times 600 \quad \dots \text{(ii)}$

Divide (ii) by (i),

$$\frac{P_1}{1} = \frac{1.29 \times 600}{1.08 \times 300}$$

$$P_1 = \frac{1.29 \times 2}{1.08} = 2.38 \text{ atm.} \approx 2.4 \text{ atm.}$$

20. (b) The compressibility factor of a gas is defined as

$$Z = \frac{pV_m}{RT}$$

For an ideal gas,  $pV_m = RT$ . Hence  $Z = 1$

21. (c) For an ideal-gas behaviour, the molecules of a gas should be far apart. The factors favouring this condition are high temperature and low pressure.

22. (c) TIPS/Formulae :

$$U_{\text{rms}} = \sqrt{\frac{3RT}{M}} \Rightarrow \sqrt{\frac{3RT_{\text{H}_2}}{2}} = \sqrt{7} \sqrt{\frac{3RT_{\text{N}_2}}{28}}$$

$$\therefore T_{\text{N}_2} = 2T_{\text{H}_2} \text{ or } T_{\text{N}_2} > T_{\text{H}_2}$$

23. (b)  $(PV)_{\text{Observed}} / (PV)_{\text{Ideal}} < 1$

$$\Rightarrow V_{\text{obs}} < V_{\text{ideal}}, V_{\text{obs}} < 22.4 \text{ litre.}$$

24. (c) Mass of 1 L of vapour = volume  $\times$  density  
 $= 1000 \times 0.0006 = 0.6 \text{ g}$

$$V \text{ of liquid water} = \frac{\text{mass}}{\text{density}} = \frac{0.6}{1} = 0.6 \text{ cm}^3$$

25. (d)  $U_{\text{RMS}} = \sqrt{\frac{3RT}{M}}$  Using ideal gas equation,

$$PV = nRT = \frac{w}{M} RT; \quad \frac{RT}{M} = \frac{PV}{w} = \frac{p}{d} \text{ where } d \text{ is the density of the gas}$$

$$\therefore U_{\text{RMS}} = \sqrt{\frac{3P}{d}} \text{ at constant pressure, } U_{\text{RMS}} \propto \frac{1}{\sqrt{d}}$$

26. (c) TIPS/Formulae :

Find the volume by either

$V = RT/P$  ( $PV = RT$ ) or  $P_1V_1 = P_2V_2$  and match it with the values given in graph to find correct answer.

Volume of 1 mole of an ideal gas at 273 K and 1 atm is 22.4 L and that at 373 K and 1 atm pressure is calculated as ;

$$V = \frac{RT}{P} = \frac{0.082 \times 373}{1} = 30.58\text{L} \approx 30.6 \text{ L}$$

27. (b) Upon increase of temperature the internal energy of water or any system increases resulting in decrease in intermolecular force and hence decrease in surface tension. Surface tension decreases with increase in mobility due to increase in temperature.

28. (c) For positive deviation:  $PV = nRT + nPb$

$$\Rightarrow \frac{PV}{nRT} = 1 + \frac{Pb}{RT}$$

Thus, the factor  $nPb$  is responsible for increasing the  $PV$  value, above ideal value.  $b$  is actually the effective volume of molecule. So, it is the finite size of molecules that leads to the origin of  $b$  and hence positive deviation at high pressure.

29. (c) Average KE =  $E = \frac{1}{2} M u_{\text{rms}}^2$

$$\therefore u_{\text{rms}}^2 = \frac{2E}{M} \text{ or } u_{\text{rms}} = \sqrt{\frac{2E}{M}}$$

30. (b) TIPS/Formulae :

Use Grahams' law of diffusion

$$\frac{r_{\text{He}}}{r_{\text{CH}_4}} = \sqrt{\frac{M_{\text{CH}_4}}{M_{\text{He}}}} = \sqrt{\frac{16}{4}} = 2$$

31. (a)  $TV^{\gamma-1} = \text{Constant}$  ( $\because$  change is adiabatic)

$$T_1V_1^{\gamma-1} = T_2V_2^{\gamma-1}$$

For monoatomic gas  $\gamma = \frac{5}{3}$

$$\therefore T_1V_1^{2/3} = T_2V_2^{2/3} \Rightarrow T(1)^{2/3} = T_2(2)^{2/3}$$

$$T_2 = \frac{T}{2^{(2/3)}}$$

32. (b) In general, the molar heat capacity for any process is given by

$$C = C_v + \frac{R}{1-n}, \text{ when } PV^n = \text{constant}$$

Here  $\frac{P}{V} = 1$ , i.e.  $PV^{-1} = \text{constant}$

For monoatomic gas,  $C_v = \frac{3}{2}R$

$$\therefore C = \frac{3}{2}R + \frac{R}{1-(-1)} = \frac{3}{2}R + \frac{R}{2} = \frac{4R}{2} = 2R.$$

33. (b) Correction factor for attractive force for  $n$  moles of real gas is given by the term mentioned in (b).

34. (c)

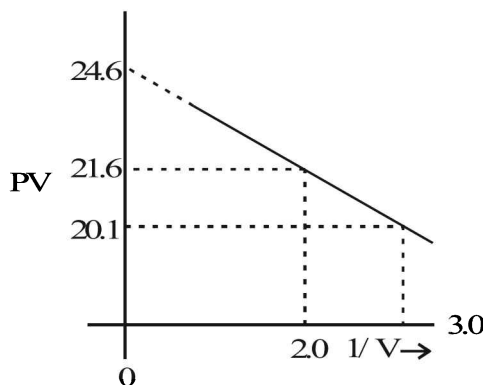

$$\left(P + \frac{a}{V^2}\right)(V) = RT$$

$$PV + a/V = RT; PV = RT - a/V$$

$$y = RT - a(x)$$

$$\text{So, slope} = a = \frac{21.6 - 20.1}{3 - 2} = \frac{1.5}{1} = 1.5$$

35. (d)

- A solution of  $\text{CH}_3\text{OH}$  and water shows positive deviation from Raoult's law, it means by adding  $\text{CH}_3\text{OH}$  intermolecular force of attraction decreases and hence surface tension decreases.
- By adding  $\text{KCl}$  in water, intermolecular force of attraction bit increases, so surface tension increases by small value.

- By adding surfactant like  $\text{CH}_3(\text{CH}_2)_{11}\text{OSO}_3^- \text{Na}^+$ , surface tension decreases rapidly and after forming micelle it slightly increases.

#### D. MCQs with One or More Than One Correct

- (b) No work is required to tear apart the molecules due to the absence of attractive forces in an ideal gas.
- (a,b) At constant temp., when gas expands the K.E. of the molecules remains the same, but the pressure decreases. ( $\because P \propto \frac{1}{V}$ )
- (d) Pressure exerted by  $\text{H}_2$  is proportional to its mole fraction.

$$\text{Mole fraction of } \text{H}_2 = \frac{\frac{W}{2}}{\frac{W}{2} + \frac{30}{30}} = \frac{30}{32} = \frac{15}{16}$$

- (c) According to Graham's law of diffusion for two gases undergoing diffusion at different pressures through same hole

$$\frac{r_A}{r_B} = \sqrt{\frac{M_B}{M_A}} \times \frac{P_A}{P_B}$$

$$\left( r \propto P \times \sqrt{\frac{1}{M}} \quad \text{At constant temperature} \right)$$

- (b) For gas A,  $a=0$ ,  $Z = 1 + \frac{Pb}{RT}$  implies  $Z$  varies linearly with pressure.

For gas B,  $b=0$ ,  $Z = 1 - \frac{a}{VRT}$ . Hence,  $Z$  does not vary linearly with pressure.

Given the intersection data for gas C, it is possible to find the values of 'a' and 'b'. All vander Waal gases, like gas C, give positive slope at high pressures.

- (a,c) Vander Waals equation is

$$\left(P + \frac{n^2a}{V^2}\right)(V - nb) = nRT \quad [\text{For } n \text{ moles of a gas}]$$

a, b are vander Waals constants

The ideal gas equation is  $PV = nRT$  [For  $n$  moles of a gas]

where  $P$  is pressure exerted by ideal gas and  $V$  is volume occupied by ideal gas.

In vander Waals equation the term  $\left(P + \frac{n^2a}{V^2}\right)$

represents the pressure exerted by the gas and  $(V - nb)$  the volume occupied by the gas. At low pressure, when

the gas occupies large volume the intermolecular distance between gaseous molecules is quite large and in such case there is no significant role played by intermolecular forces and thus the gas behaves like an ideal gas thus (a) is correct

**NOTE:** Under high pressure the intermolecular distance decreases and the intermolecular forces play a significant role and the gas shows a deviation from ideal behaviour.

Thus (b) is *not* correct.

a, b i.e. the vander Waals coefficients defined on the nature of gas and are independent of temperature so (c) is correct.

The pressure  $\left(P + \frac{n^2 a}{V}\right)$  is not lower than  $P$  so (d) is

not correct.

Hence the correct answer is (a, c).

7. (a, b, c, d)

8. (c)  $P(V-b) = RT$

$$\Rightarrow PV - Pb = RT$$

$$\Rightarrow \frac{PV}{RT} = \frac{Pb}{RT} + 1$$

$$\Rightarrow Z = 1 + \frac{Pb}{RT}$$

Hence  $Z > 1$  at all pressures.

This means, repulsive tendencies will be dominant when interatomic distances are small.

This means, interatomic potential is never negative but becomes positive at small interatomic distances.

### E. Subjective Problems

1. TIPS/Formulae :

$$PV = \frac{m}{M} RT \Rightarrow P = \frac{m}{V} \times \frac{RT}{M} = d \frac{RT}{M} \therefore d = \frac{MP}{RT}$$

Substituting the value, we get

$$d = \frac{17 \times 5}{0.082 \times 303} = 3.42 \text{ g/litre}$$

2. Given, moles =  $\frac{\text{mass}}{\text{mol. wt}}$

mass of gas = 3.7g, mass of hydrogen = 0.184g

$$T_1 = 298\text{K}, T_2 = 17^\circ\text{C} = 273 + 17 = 290\text{K}$$

$$\text{Moles of H}_2 = n_1 = \frac{\text{Mass}}{\text{M. wt.}} = \frac{0.184}{2} = 0.092$$

$$\text{Moles of gas} = n_2 = \frac{\text{Mass}}{\text{M. wt.}} = \frac{3.7}{M}$$

$$\text{For hydrogen } P_1 V_1 = n_1 RT_1 \quad \dots\dots\dots(i)$$

$$\text{For gas } P_1 V_1 = n_2 RT_2 \quad \dots\dots\dots(ii)$$

( $\because$  Pressure and volume of gas are same)

$\therefore$  From equation (i) and equation (ii)

$$\frac{P_1 V_1}{P_1 V_1} = \frac{n_1 RT_1}{n_2 RT_2} \text{ or } 1 = \frac{0.092 \times 298}{n_2 \times 290}$$

$$\text{or } n_2 = \frac{0.092 \times 298}{290} \text{ or } \frac{3.7}{M} = \frac{0.092 \times 298}{290}$$

$$\text{or } \frac{3.7}{M} = 0.0945 \therefore M = \frac{3.7}{0.0945} = 39.15$$

3. Let  $\text{NH}_3$  diffuse through =  $x$  cm

$\text{HCl}$  diffuses through =  $y$  cm

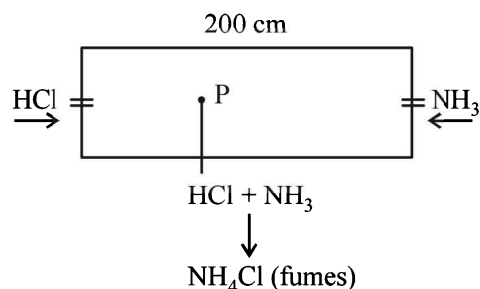

According to Graham's law of diffusion

$$\frac{x}{y} = \sqrt{\frac{\text{Mol. wt HCl}}{\text{Mol. wt of NH}_3}} = \sqrt{\frac{36.5}{17}} = \sqrt{2.14} = 1.465$$

$$x = 1.465 y \quad \dots(1)$$

$$x + y = 200 \text{ cm} \quad \dots(2)$$

From these equations;  $y = 85.2$  cm

Distance between P and X =  $y = 85.2$  cm.

4. Following reaction takes place in tube

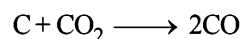

Volume of mixture of CO and  $\text{CO}_2 = 1\text{L}$

Let volume of  $\text{CO}_2$  in mixture =  $x$

$\therefore$  Volume of CO in mixture =  $2x$

$\therefore$  Original volume of CO in mixture =  $1 - x$

Total volume of CO after reaction =  $(1 - x) + 2x = 1 + x$

$1 + x = 1.6$  ( $\because$  It is given total volume after reaction = 1.6L)

$\therefore x = 0.6\text{L} \therefore$  Volume of  $\text{CO}_2 = 0.6\text{L}$

Volume of CO = 0.4 L

$\text{CO}_2 : \text{CO} = 3 : 2$

5. Since the pressures of gases are different, and the temperature is constant, the rate at which molecules of the two gases diffuse is directly proportional to the pressure. This rate of diffusion is also directly proportional to the distance travelled by the gas. Hence

$$r_1 \text{ (of HCl gas) at pressure } P = 60 = \frac{kP}{\sqrt{36.5}} \quad \dots\dots(i)$$

$$\text{and } r_2 \text{ (of NH}_3\text{) at 1 atm. pressure } P = 40 = \frac{k \times 1}{\sqrt{17}} \quad \dots\dots(ii)$$



From (i) and (ii)

$$\frac{r_1}{r_2} = \frac{60}{40} = \frac{kP}{\sqrt{36.5}} \times \frac{\sqrt{17}}{k \times 1}$$

$$P = \frac{60}{40} \times \frac{\sqrt{36.5}}{\sqrt{17}} = 2.197 \text{ atm}$$

### 6. TIPS/Formulae :

Total kinetic energy =  $n(3/2 RT)$

where  $n$  = Number of moles of the gas

$R$  = Gas constant

$T$  = Absolute temperature

Molecular weight of methane,

$$\text{CH}_4 = 12 + 4 \times 1 = 16$$

$\therefore$  Number of moles of methane in 8.0 gm of methane

$$= \frac{8.0}{16.0} = 0.5$$

$$R = 8.314 \text{ joules/K/mole}, \quad T = 27 + 273 = 300 \text{ K}$$

$\therefore$  Total kinetic energy of the molecules in 8.0 gm of methane at  $27^\circ\text{C} = n \times 3/2 RT = 0.5 \times 3/2 \times 8.314 \times 300 = 1870.65 \text{ joules}$

$$\therefore \text{Average kinetic energy} = \frac{1870.65}{6.023 \times 10^{23} \times 0.5}$$

$$= 6.21 \times 10^{-21} \text{ joules/molecule}$$

### 7. NOTE THIS STEP :

First we should calculate the number of moles of the gas under the given conditions by the relation  $PV = nRT$

Here  $P = 7.6 \times 10^{-10} \text{ mm Hg}$

$$= \frac{7.6 \times 10^{-10}}{760} \text{ atm} = 1 \times 10^{-12} \text{ atm.}$$

$$V = 1 \text{ litre}, T = 273 + 0 = 273 \text{ K}, R = 0.082 \text{ litre atm./K/mol}$$

Putting the values in equation

$$n = \frac{PV}{RT} = \frac{1 \times 10^{-12} \times 1}{0.082 \times 273} \text{ moles}$$

Now since 1 mole =  $6.023 \times 10^{23}$  molecules

$$\frac{10^{-12}}{0.082 \times 273} \text{ moles} = \frac{6.023 \times 10^{23} \times 10^{-12}}{0.082 \times 273} \text{ molecules}$$

$$= 2.7 \times 10^{10} \text{ molecules}$$

### 8. From ideal gas equation,

$$PV = nRT \Rightarrow PV = \left(\frac{m}{M}\right) RT \text{ or } M = m \frac{RT}{PV}$$

Let the molecular wt. of A and B be  $M_A$  and  $M_B$  respectively.

$$\text{Then } M_A = 2 \frac{RT}{1 \times V}; \quad M_B = \frac{3 \times RT}{0.5 \times V}$$

$$\therefore \frac{M_A}{M_B} = \frac{2RT}{V} \times \frac{0.5V}{3RT} = \frac{2 \times 0.5}{3} = \frac{1}{3}$$

Therefore, the ratio  $M_A : M_B = 1 : 3$

$$9. \quad U_{\text{rms}} = \sqrt{\frac{3RT}{M}}$$

$$\text{Given } T = 20^\circ\text{C} = 20 + 273 = 293 \text{ K}$$

$$R = 8.314 \times 10^7 \text{ erg per degree per mol}$$

$$M(\text{of O}_3) = 48$$

$$\therefore U_{\text{rms}} = \sqrt{\frac{3 \times 8.314 \times 10^7 \times 293}{48}} = 3.9 \times 10^4 \text{ cm sec}^{-1}$$

### 10. Volume of ballon = 4.851 L (as calculated above)

Let no. of balloons to be filled =  $n$

$$\therefore \text{Total volume occupied by } n \text{ balloons} = 4.851 \times n$$

Volume of  $\text{H}_2$  present in cylinder = 2.82 L (given)

$$\therefore \text{Total volume of } \text{H}_2 \text{ at NTP} = (4.851n + 2.82) \text{ L}$$

$$P_1 = 1 \text{ atm}$$

$$P_2 = 20 \text{ atm}$$

$$V_1 = 4.85 \times n + 2.82 \text{ L}$$

$$V_2 = 2.82 \text{ L}$$

$$T_1 = 273 \text{ K}$$

$$T_2 = 300 \text{ K}$$

$$\frac{P_1 V_1}{T_1} = \frac{P_2 V_2}{T_2} \text{ or } \frac{1 \times (4.85 \times n + 2.82)}{273} = \frac{20 \times 2.82}{300}$$

$$\therefore n = \frac{48.504}{4.851} \approx 10$$

### 11. TIPS/Formulae :

$$\text{Average velocity} = \sqrt{\frac{8RT}{\pi M}}$$

$$\text{and Most probable velocity} = \sqrt{\frac{2RT}{M}}$$

Given -For  $\text{CO}_2$

Average velocity at  $T_1$  = Most probable velocity at  $T_2$

$$= 9 \times 10^4 \text{ cm/sec} = \frac{9 \times 10^4}{100} \text{ m/sec.}$$

$$= 9 \times 10^2 \text{ m/sec.}$$

$$\therefore 9 \times 10^2 = \sqrt{\frac{8 \times 8.314 \times T_1}{3.14 \times 44 \times 10^{-3}}} \quad \dots(\text{A})$$

[Average velocity at  $T_1 \text{ K}$ ]

$$\text{and } 9 \times 10^2 = \sqrt{\frac{2 \times 8.314 \times T_2}{44 \times 10^{-3}}} \quad \dots(\text{B})$$

[Most probable velocity at  $T_2 \text{ K}$ ]

On solving,  $T_1 = 1682.5 \text{ K}$ ,  $T_2 = 2143.4 \text{ K}$

### 12. Applying the general gas equation

$$PV = nRT = \frac{m}{M} RT$$

$$\text{Here, Mol. wt. of acetylene i.e., } \text{C}_2\text{H}_2 \text{ (M)} = 26, P = \frac{740}{760} \text{ atm,}$$

$$T = 50^\circ\text{C} = 50 + 273 = 323 \text{ K}$$

$$\therefore V = \frac{mRT}{MP} \text{ or } V = \frac{5 \times 0.082 \times 323 \times 760}{26 \times 740} = 5.23 \text{ L}$$

13. Using gas equation;
- $PV = nRT$

Total no. of moles of gases in the mixture (n)

$$= \frac{PV}{RT} = \frac{6 \times 3}{0.0821 \times 300} = 0.7308 \text{ mol.}$$

Thus no. of moles of unknown gas =  $0.7308 - 0.7 = 0.0308 \text{ mol.}$ 

Now we know that

$$\frac{r_1}{r_2} = \frac{\text{moles of hydrogen gas}}{\text{moles of unknown gas}} = \frac{0.7}{0.0308}$$

$$\text{Also we know that } \frac{r_1}{r_2} = \sqrt{\frac{M_2}{M_1}}$$

$$\therefore M_2 = \left(\frac{r_1}{r_2}\right)^2 M_1 \text{ or } M_2 = \left(\frac{0.7}{0.0308}\right)^2 \times 2 = 1033$$

- 14.
- $2\text{NO} + \text{O}_2 \rightarrow 2\text{NO}_2 \rightarrow \text{N}_2\text{O}_4$

Calculating the number of moles of NO and  $\text{O}_2$  by applying

$$\text{the formula, } n = \frac{PV}{RT}$$

$$\text{Moles of NO in the larger flask} = \frac{1.053 \times 0.250}{0.082 \times 300} = 0.0107$$

$$[250 \text{ mL} = 0.250 \text{ L}]$$

$$\text{Moles of } \text{O}_2 \text{ in the smaller flask} = \frac{0.789 \times 0.100}{0.082 \times 300} = 0.0032$$

$$[100 \text{ mL} = 0.100 \text{ L}]$$

The reaction takes place as follows.

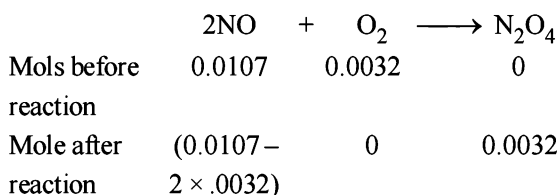
Hence moles of NO reacting completely with 0.0032 moles of  $\text{O}_2 = 2 \times 0.0032 = 0.0064$ Moles of NO left =  $0.0107 - 0.0064 = 0.0043$ 

**NOTE :** Oxygen will be completely changed into  $\text{NO}_2$  which in turn is completely converted into  $\text{N}_2\text{O}_4$  which solidifies at 262 K. Hence at 220 K, the dimer is in the solid state and only NO present in excess will remain in the gaseous state occupying volume equal to 350 ml.

Hence pressure (P) of NO gas left

$$= \frac{nRT}{V} = \frac{0.0043 \times 0.082 \times 220}{0.350} = 0.221 \text{ atm}$$

$$[\text{Total volume} = 0.250 + 0.100 = 0.350 \text{ L}]$$

15. Given
- $V = 1 \text{ L} = 10^{-3} \text{ m}^3$
- ,
- $P = 7.57 \times 10^{-3} \text{ Nm}^{-2}$
- ,
- $R = 8.314 \text{ J}$
- ,
- 
- $n = 2 \times 10^{21} / 6.023 \times 10^{23}$
- moles

$$PV = nRT \text{ or } T = \frac{PV}{nR}$$

$$= \frac{7.57 \times 10^{-3} \times 10^{-3} \times 6.023 \times 10^{23}}{2 \times 10^{21} \times 8.31} = 274.13 \text{ K}$$

$$U_{\text{rms}} = \sqrt{\frac{3RT}{M}} = \sqrt{\frac{3 \times 8.314 \times 274.13}{28 \times 10^{-3}}} \text{ m/s} = 494.15 \text{ m/s}$$

(Given U)

$$\frac{U_{\text{mp}}}{U_{\text{rms}}} = 0.82 \text{ (given)}$$

$$\therefore U_{\text{mp}} = 0.82 \times U_{\text{rms}} = 0.82 \times 494.15 = 405.2 \text{ m/sec}$$

- 16.
- TIPS/Formulae :**

Partial pressure = Mole fraction  $\times$  Total pressure

$$\therefore p_{\text{He}} = x_{\text{He}} \times P = \frac{4}{5} \times 20 = 16 \text{ bar}$$

$$\left[ \text{mole fraction of He} = \frac{4}{5} \right]$$

$$\therefore p_{\text{CH}_4} = 20 - 16 = 4 \text{ bar}$$

Now applying the formula

$$\frac{r_{\text{He}}}{r_{\text{CH}_4}} = \frac{P_{\text{He}}^0}{P_{\text{CH}_4}^0} \sqrt{\frac{M_{\text{CH}_4}}{M_{\text{He}}}} = \frac{16}{4} \sqrt{\frac{16}{4}} = \frac{16}{4} \sqrt{4}$$

$$\therefore r_{\text{He}} : r_{\text{CH}_3} = 8 : 1$$

∴ Composition of the mixture (He :  $\text{CH}_4$ ) effusing out = **8 : 1**

- 17.
- Calculation of volume of gas :**

Weight of cylinder with gas = 29.0 kg

Weight of empty cylinder = 14.8 kg

∴ Weight of gas in the cylinder = 14.2 kg

Pressure in cylinder = 2.5 atm

∴ No. of moles (n) in 14.2 kg ( $14.2 \times 10^3$  g) of butane

$$n = \frac{\text{Wt. of butane}}{\text{Mol. wt. of butane}} = \frac{14.2 \times 10^3}{58} = 244.83 \text{ mol}$$

Applying gas equation,

$$V = \frac{nRT}{P} = \frac{244.83 \times 0.0821 \times 300}{2.5} = 2412 \text{ litres}$$

$$[27^\circ\text{C} = 273 + 27 = 300]$$

**Calculation of pressure in cylinder after use.**

Weight of cylinder after use = 23.2 kg

Weight of empty cylinder = 14.8 kg

$$\therefore \text{Wt. of unused gas} = 8.4 \text{ kg} = \frac{8.4 \times 10^3}{58} \text{ moles of butane}$$

$$\text{Thus } P = \frac{nRT}{V} = \frac{8.4 \times 10^3 \times 0.0821 \times 300}{58 \times 2412} = 1.478 \text{ atm}$$

$$[V = 2412 \text{ L}]$$

Calculation of volume of used gas at 2.5 atm and 27°C.

Weight of used gas = 14.2 – 8.4 = 5.8 kg

Pressure under normal usage conditions = 1 atm

$$V = \frac{nRT}{P} = \frac{5.8 \times 10^3}{58} \times \frac{0.0821 \times 300}{1} \quad \left[ \because n = \frac{5.8}{58} \right]$$

$$= 2463 \text{ litres} = \mathbf{2.463 \text{ m}^3}$$

18. Let the volume of ethane in mixture =  $x$  litre

$\therefore$  Volume of ethene =  $(40 - x)$  litre

Combustion reactions of ethane and ethene are :

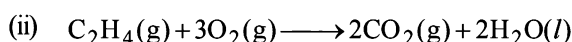
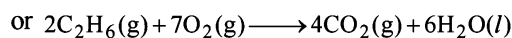
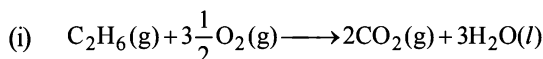

Volume of  $O_2$  required for complete combustion of ethane

$$= \frac{7x}{2} \quad [\text{For } x \text{ litres}]$$

Volume of  $O_2$  required for complete combustion of ethene  
=  $(40 - x) \times 3$  [For  $(40 - x)$  L]

$$\therefore \text{Total volume of } O_2 \text{ required} = \frac{7x}{2} + (40 - x)3 \text{ l}$$

Calculation of number of moles ( $n$ )

$$P = 1 \text{ atm}, V = \frac{7x}{2} + (40 - x)3 \text{ l}; R = 0.082 \text{ l atm K}^{-1} \text{ mol}^{-1},$$

$$T = 400 \text{ K}$$

$$\text{Since } n = \frac{PV}{RT} = \frac{1 \times \left[ \frac{7x}{2} + (40 - x)3 \right]}{0.082 \times 400} = \frac{7x + (40 - x)6}{2 \times 0.082 \times 400}$$

$$\text{Mass of } n \text{ moles of } O_2 = \left[ \frac{7x + (40 - x)6}{2 \times 0.082 \times 400} \right] \times 32 = 130$$

$$\text{or } 130 = \left[ \frac{7x + 240 - 6x}{65.6} \right] \times 32$$

$$\Rightarrow 8528 = 32x + 240 \times 32 \Rightarrow 32x = 848 \Rightarrow \text{or } x = \frac{848}{32} = 26.5$$

$$\text{Hence mole fraction (\%)} \text{ of ethane} = \frac{26.5}{40} \times 100 = \mathbf{66.25\%}$$

Mole fraction (%) of ethene = **33.75%**

19. Mixture

Krypton

$$r_{\text{mix}} = 1.16$$

$$r_{\text{Kr}} = 1$$

$$M_{\text{mix}} = ?$$

$$M_{\text{Kr}} = 84$$

We know that

$$\frac{r_{\text{mix}}}{r_{\text{Kr}}} = \sqrt{\frac{M_{\text{Kr}}}{M_{\text{min}}}} \quad \text{or} \quad \frac{1.16}{1} = \sqrt{\frac{84}{M_{\text{mix}}}}$$

$$\text{or } (1.16)^2 = \frac{84}{M_{\text{mix}}} \Rightarrow M_{\text{mix}} = \frac{84}{(1.16)^2} = 62.426$$

Determination of the composition of the equilibrium mixture

Let the fraction of  $Cl_2$  molecules dissociated at equilibrium =  $x$

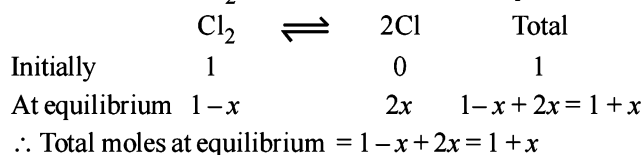

$$\therefore \frac{\text{Normal molecular mass}}{\text{Experimental molecular mass}} = 1 + x$$

$$\therefore \frac{71}{64.426} = 1 + \alpha$$

$$\therefore \alpha = 0.137 = \mathbf{13.7\%}$$

20. TIPS/Formulae :

(i) He does not react with oxygen.

(ii) KOH absorbs only  $CO_2$ .

**NOTE :** When the mixture of  $CO$ ,  $CH_4$  and He gases (20 ml) are exploded by an electric discharge with excess of  $O_2$ , He gas remains as such and the other reactions involved are :

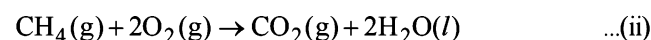
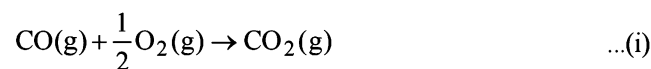

Let the volumes of  $CO$  and  $CH_4$  to be ' $a$ ' ml and ' $b$ ' ml in the mixture then

Volume of He gas =  $[20 - (a + b)]$  ml

For the initial contraction of 13 ml,

Volume of left hand side in the above reactions – 13 = Volume of right hand side.

$$\therefore [20 - (a + b)] + \left( a + \frac{1}{2}a \right) + (b + 2b) - 13$$

$$= [20 - (a + 2b)] + a + b \quad [\text{neglect the volume of } H_2O(l)]$$

(Since for gases, volume  $\propto$  no. of moles)

$$\therefore \frac{1}{2}a + 2b = 13 \quad \text{or} \quad a + 4b = 26 \quad \dots(iv)$$

**NOTE THIS STEP :** The  $CO_2$  produced above in reactions (ii) & (iii),  $(a + b)$  ml, reacts with KOH sol for a further contraction of 14 ml.

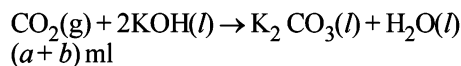

$$\therefore a + b = 14 \quad \dots(v)$$

Solving (iv) & (v) we get,  $a = 10$  ml &  $b = 4$  ml

$$\therefore CH_4 = \frac{4}{20} \times 100 = \mathbf{20\%}, \quad CO = \frac{10}{20} \times 100 = \mathbf{50\%}$$

& He =  $100 - (20 + 50) = \mathbf{30\%}$

21. Weight of liquid =  $148 - 50 = 98$  g

$$\text{Volume of liquid} = \frac{98}{0.98} = 100 \text{ ml} = \text{volume of vessel}$$

It means, vessel of 100 ml contains ideal gas at 760 mm Hg at 300 K

$$\text{Weight of gas} = 50.5 - 50 = 0.5 \text{ g}$$

using,  $PV = nRT = \frac{w}{m} RT$

$$\frac{760}{760} \times \frac{100}{1000} = \frac{0.5}{m} \times 0.082 \times 300 \quad \left[ n = \frac{0.5}{m} \right]$$

$\therefore$  Molecular weight of gas ( $m$ ) = **123**

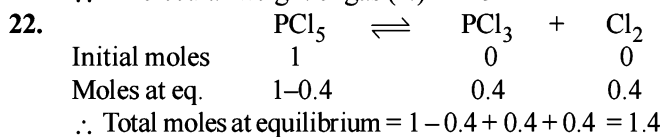

Also  $\frac{\text{Normal mol. wt. of PCl}_5}{\text{Exp. mol. wt. of PCl}_5} = 1 + \alpha = 1.4$

or  $\frac{208.5}{\text{Exp. mol. wt. of PCl}_5} = 1.4$

$\therefore$  Exp. mol. wt. of PCl<sub>5</sub> or m. wt. of mixture =  $\frac{208.5}{1.4}$

Now using,  $PV = \frac{w}{m} RT$  for mixture

$$d = \frac{w}{V} = \frac{Pm}{RT} = \frac{1 \times 208.5}{1.4 \times 0.082 \times 400} = \mathbf{4.53 \text{ g/litre}}$$

23. van der Waals equation for  $n$  moles of gas is

$$\left[ P + \frac{n^2 a}{V^2} \right] [V - nb] = nRT$$

Given  $V = 4$  litre;  $P = 11.0$  atm,  $T = 300$  K;  
 $b = 0.05$  litre mole<sup>-1</sup>,  $n = 2$

Thus,  $\left[ 11 + \frac{2^2 a}{4^2} \right] [4 - 2 \times 0.05] = 2 \times 0.082 \times 300$

$\therefore a = \mathbf{6.46 \text{ atm litre}^2 \text{ mol}^{-2}}$

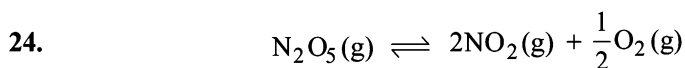

Initial pressure	600	0	0
Final pressure	600-P	2P	P/2

$P \propto$  moles when  $V$  and  $T$  are constant  
(where moles equivalent to pressure  $P$  are decomposed)  
Total pressure = 600 -  $P$  + 2  $P$  +  $P/2$  = 960 mm of Hg  
 $\therefore P = 240$  mm Hg

Thus moles of N<sub>2</sub>O<sub>5</sub> decomposed =  $\frac{240}{600} = \mathbf{0.4}$

25. We know that

$$\frac{r_1}{r_2} = \sqrt{\frac{M_2}{M_1}} \times \frac{P_1}{P_2} \quad \text{or} \quad \frac{n_1}{t_1} \times \frac{t_2}{n_2} = \sqrt{\frac{M_2}{M_1}} \times \frac{P_1}{P_2}$$

or  $\frac{1}{38} \times \frac{57}{1} = \sqrt{\frac{M}{28}} \times \frac{0.8}{1.6} \quad \therefore M = 252$

$$\left[ \text{Xe} + (F)_x = 252 \right]$$

$$131 + 19x = 252; \quad \therefore x = 6$$

Thus compound of xenon with fluorine is **XeF<sub>6</sub>**

26. (I) Given  $P = 1$  atm,  $w = 12$  g;  $T = (t + 273)$  K;  $V = V$  litre

(II) If  $T = t + 10 + 273 = t + 283$  K;  $V = V$  litre,

$$P = 1 + \frac{10}{100} = 1.1 \text{ atm}$$

Using gas equation,  $PV = \frac{w}{m} RT$

Case I.  $1 \times V = \frac{12}{m} R(t + 273) \quad \dots (1)$

Case II.  $1.1 \times V = \frac{12}{m} R(t + 283) \quad \dots (2)$

From (1) and (2),  $t = -173^\circ\text{C}$  or  $t = \mathbf{100 \text{ K}}$

27. Also from (1), on substituting  $t$  and  $m$  (120),  $V = \mathbf{0.82 \text{ litre}}$   
van der Waals' equation for one mole of a gas is

$$\left[ P + \frac{a}{V^2} \right] (V - b) = RT \quad \dots (1)$$

Given that volume occupied by CO<sub>2</sub> molecules, ' $b$ ' = 0

Hence, (1) becomes  $\left[ P + \frac{a}{V^2} \right] V = RT$  or  $P = \frac{RT}{V} - \frac{a}{V^2}$

Using  $R = 0.082$ ,  $T = 273$  K,  $V = 22.4$  l for 1 mole of an ideal gas at 1 atm pressure.

$$\therefore P = \frac{0.082 \times 273}{22.4} - \frac{3.592}{(22.4)^2} = \mathbf{0.9922 \text{ atm.}}$$

28. We know that, Compressibility factor,  $Z = \frac{PV}{RT}$

$$0.5 = \frac{100 \times V}{0.082 \times 273} \quad \therefore V = 0.1119 \text{ L}$$

NOTE : Further when volume of a gas molecule is negligible, van der Waal's equation becomes

$$\left( P + \frac{a}{V^2} \right) (V - 0) = RT$$

or  $PV = RT - \frac{a}{V}$  or  $a = RTV - PV^2$

Substituting the values

$$a = (0.082 \times 0.1119 \times 273) - (100 \times 0.1119 \times 0.1119) = \mathbf{1.253 \text{ atm L}^2 \text{ mol}^{-2}}$$

29. (a)  $d = 0.36 \text{ kg m}^{-3} = 0.36 \text{ g/L}$

(i) From Graham's Law of diffusion

$$\frac{r_v}{r_{\text{O}_2}} = \sqrt{\frac{M_{\text{O}_2}}{M_v}}; \quad 1.33 = \sqrt{\frac{32}{M_v}}$$

$$\therefore M_v = \frac{32}{(1.33)^2} = \mathbf{18.09};$$

where  $M_v = MW$  of the vapour

(ii) Thus,  $0.36 \text{ g} = \frac{0.36}{18.09} \text{ mol}$

$$\frac{0.36}{18.09} \text{ mol occupies 1 L volume, so 1 mol occupies } \frac{18.09}{0.36} \text{ L} = \mathbf{50.25 \text{ L}}$$

Thus, molar volume of vapour = **50.25 L**

Assuming ideal behaviour the volume of the vapour can be calculated by

$$\frac{V_1}{T_1} = \frac{V_2}{T_2} \Rightarrow V_2 = 22.4 \times \frac{500}{273} = \mathbf{41.025 \text{ L}}$$

(iii) Compressibility factor ( $Z$ )

$$= \frac{(PV)_{\text{obs}}}{(PV)_{\text{ideal}}} = \frac{1 \times 50.25}{1 \times 41.025} = \mathbf{1.224}$$

(iv)  $Z$  is greater than unity, hence it is the short range repulsive force that would dominate.

( $\because$  actual density is less than given density)

$$(b) E = \frac{3}{2}KT = \frac{3}{2} \times \frac{8.31}{6.02 \times 10^{23}} \times 100$$

$$= 2.07 \times 10^{-20} \text{ J per molecule}$$

( $\because$   $K$ , Boltzmann constant =  $R/N$ )

### 30. TIPS/Formulae :

$$C_{\text{rms}} = \sqrt{\frac{3RT}{M}}, C_{\text{av}} = \sqrt{\frac{8RT}{\pi M}}$$

$$\frac{C_{\text{rms}}}{C_{\text{av}}} = \sqrt{\frac{3RT}{M}} \times \sqrt{\frac{\pi M}{8RT}} = \sqrt{\frac{3\pi}{8}} = 1.085$$

$$C_{\text{rms}} = 1.085 \times C_{\text{av}} = 1.085 \times 400 = 434 \text{ ms}^{-1}$$

31. The van der Waal equation (for one mole) of a real gas is

$$\left( P + \frac{a}{V_m^2} \right) (V_m - b) = RT; PV_m - Pb + \frac{a}{V_m} - \frac{ab}{V_m^2} = RT$$

$$PV_m = RT + Pb - \frac{a}{V_m} + \frac{ab}{V_m^2} \quad \dots(i)$$

**NOTE THIS STEP:** To calculate the intercept  $P \rightarrow 0$ , hence  $V_m \rightarrow \infty$  due to which the last two terms on the right side of the equation (i) can be neglected.

$$\therefore PV_m = RT + Pb$$

When  $P = 0$ , intercept =  $RT$

### F. Match The Following

- (A) : (p) and (s) Because 200 atm pressure is very large. For  $H_2$  gas, at very high pressure  $Z > 1$ .
- (B) : (r) Since  $P \sim 0$ , it means very low pressure, so ideal behaviour is observed.
- (C) : (p) and (q) Since  $P$  is 1 atm,  $Z$  for  $CO_2$  would be less than 1.
- (D) : (r) In real gas with very high molar volume, molecules will be very far apart from each other due to which van der Waal's forces as well as actual volume occupied by molecules will be negligible.

### G. Comprehension Based Questions

- (c) According to Graham's law of diffusion, if all conditions are identical,

$$r = \frac{1}{\sqrt{M}}$$

As in this question, all conditions are identical for X and Y, then

$$\frac{r_x}{r_y} = \sqrt{\frac{M_y}{M_x}}$$

$$\frac{d}{24-d} = \sqrt{\frac{40}{10}} = 2$$

$$\Rightarrow d = 48 - 2d \Rightarrow 3d = 48 \Rightarrow d = 16 \text{ cm}$$

- (d) The general formula of mean free path ( $\lambda$ ) is

$$\lambda = \frac{RT}{\sqrt{2}\pi d^2 N_A p}$$

( $d$  = diameter of molecule,  $p$  = pressure inside the vessel)

Since  $d$  and  $p$  are same for both gases, ideally their  $\lambda$  are same. Hence it must be the higher drift speed of X due to which it is facing more collisions per second with the inert gas in comparison to gas Y. Hence X faces more resistance from inert gas than Y and hence covers lesser distance than that predicted by Graham's law.

### H. Assertion & Reason Type Questions

- (a) 'a' indicates the magnitude of the attractive forces among the gas molecules, which increases in  $NH_3$  due to H-bonding.
- (a) At constant volume.

$$P \propto T \quad (\text{from } PV = nRT)$$

$$U_{\text{rms}} = \sqrt{\frac{3RT}{M}} \quad \therefore U_{\text{rms}} \propto \sqrt{T} \quad \dots(i)$$

Collision frequency is directly proportional to  $U_{\text{rms}}$ .

Thus collision frequency  $\propto \sqrt{T}$

Hence, on increasing the collision pressure, increases frequency.

### I. Integer Value Correct Type

$$1. v_{\text{rms}} \text{ of X} = \sqrt{\frac{3RT_x}{M_x}}; v_{\text{mp}} \text{ of Y} = \sqrt{\frac{2RT_y}{M_y}}$$

$$\text{Given } v_{\text{rms}} = v_{\text{mp}} \Rightarrow \sqrt{\frac{3RT_x}{M_x}} = \sqrt{\frac{2RT_y}{M_y}}$$

$$\Rightarrow M_y = \frac{2RT_y M_x}{3RT_x} = \frac{2 \times 60 \times 40}{3 \times 400} = 4$$

- 7

$$P_{\text{He}} = 1 - 0.68 = 0.32 \text{ atm}, n = 0.1$$

$$V = \frac{nRT}{P} = \frac{0.1 \times 0.0821 \times 273}{0.32} = 7$$

- (4) Diffusion coefficient  $\propto \lambda \mu$

$$\text{Since } \lambda \propto \frac{T}{P} \text{ and } \mu \propto \sqrt{T}$$

$$\therefore \text{Diffusion coefficient} \propto \frac{T\sqrt{T}}{P}$$

$$\text{Thus } \frac{D_i}{D_f} = \frac{\frac{T\sqrt{T}}{P}}{\frac{4T\sqrt{4T}}{2P}} = \frac{1}{(4 \times 2)/2} = \frac{1}{4} \quad \text{or} \quad \frac{D_f}{D_i} = \frac{4}{1}$$

## Section-B

## JEE Main/ AIEEE

- (c)  $PV = nRT$  (number of moles =  $n/V$ )  $\therefore n/V = P/RT$ .
  - (c) Value of gas constant  
 $(R) = 0.0821 \text{ L atm K}^{-1} \text{ mol}^{-1}$   
 $= 8.314 \times 10^7 \text{ ergs K}^{-1} \text{ mol}^{-1}$   
 $= 8.314 \text{ JK}^{-1} \text{ mol}^{-1} = 1.987 \text{ cal K}^{-1} \text{ mol}^{-1}$
  - (d) Kinetic theory of gases proves all the given gas laws.
  - (b) According to kinetic theory the gas molecules are in a state of constant rapid motion in all possible directions colliding in a random manner with one another and with the walls of the container and between two successive collisions molecules travel in a straight line path but show haphazard motion due to collisions.
- (a)  $\frac{\text{K.E of neon at } 40^\circ\text{C}}{\text{K.E of neon at } 20^\circ\text{C}} = \frac{\frac{3}{2} \text{K} \times 313}{\frac{3}{2} \text{K} \times 293} = \frac{313}{293}$
  - (a) In van der waals equation 'b' is for volume correction
  - (c) Distribution of molecular velocities at two different temperature is given shown below.

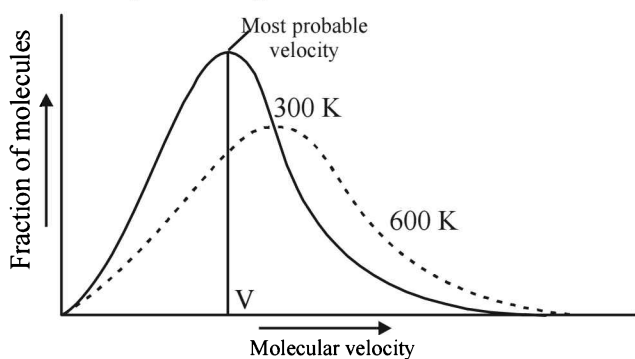

**NOTE :** At higher temperature more molecules have higher velocities and less molecules have lower velocities.

As evident from fig. thus it is clear that With the increase in temperature the most probable velocity increase but the fraction of such molecules decreases.

- (d) From the ideal gas equation :  
 $PV = nRT$  or  $n = \frac{PV}{RT} = \frac{3170 \times 10^{-3}}{8.314 \times 300} = 1.27 \times 10^{-3}$
- (d) The value of  $a$  is a measure of the magnitude of the attractive forces between the molecules of the gas. Greater the value of 'a', larger is the attractive intermolecular force between the gas molecules. The value of  $b$  related to the effective size of the gas molecules. It is also termed as excluded volume. The gases with higher value of  $a$  and lower value of  $b$  are more liquefiable, hence for  $\text{Cl}_2$  "a" should be greater than for  $\text{C}_2\text{H}_6$  but for it  $b$  should be less than for  $\text{C}_2\text{H}_6$ .
- (c)  $\left(P + \frac{a}{V^2}\right)(V - b) = RT$  at high pressure  $\frac{a}{V^2}$  can be neglected  
 $PV - Pb = RT$  and  $PV = RT + Pb$   
 $\frac{PV}{RT} = 1 + \frac{Pb}{RT}$

$$Z = 1 + \frac{Pb}{RT}; Z > 1 \text{ at high pressure}$$

$$11. \text{ (c) Most probable speed } (C^*) = \sqrt{\frac{2RT}{M}}$$

$$\text{Average Speed } (\bar{C}) = \sqrt{\frac{8RT}{\pi M}}$$

$$\text{Root mean square velocity } (c) = \sqrt{\frac{3RT}{M}}$$

$$C^* : \bar{C} : C = \sqrt{\frac{2RT}{M}} : \sqrt{\frac{8RT}{\pi M}} : \sqrt{\frac{3RT}{M}}$$

$$= 1 : \sqrt{\frac{4}{\pi}} : \sqrt{\frac{3}{2}} = 1 : 1.128 : 1.225$$

$$12. \text{ (b) Compressibility factor } (Z) = \frac{PV}{RT}$$

(For one mole of real gas)  
van der Waals equation

$$\left(P + \frac{a}{V^2}\right)(V - b) = RT$$

At low pressure, volume is very large and hence correction term  $b$  can be neglected in comparison to very large volume of  $V$ .

i.e.  $V - b \approx V$

$$\left(P + \frac{a}{V^2}\right)V = RT; PV + \frac{a}{V} = RT$$

$$PV = RT - \frac{a}{V}; \frac{PV}{RT} = 1 - \frac{a}{VRT}$$

$$\text{Hence, } Z = 1 - \frac{a}{VRT}$$

$$13. \text{ (b) Number of moles of } \text{O}_2 = \frac{w}{32}$$

$$\text{Number of moles of } \text{N}_2 = \frac{4w}{28} = \frac{w}{7}$$

$$\therefore \text{Ratio} = \frac{w}{32} : \frac{w}{7} = 7 : 32$$

- (b) Hydrogen bond is a type of strong electrostatic dipole-dipole interaction and dependent on the inverse cube of distance between the molecular ion-dipole interaction  $\propto \frac{1}{r^3}$ .

- (a) For a given mass of an ideal gas, the volume and amount (moles) of the gas are directly proportional if the temperature and pressure are constant. i.e

$$V \propto n$$

Hence in the given case.

Initial moles and final moles are equal  $(n_T)_i = (n_T)_f$

$$\frac{P_i V}{RT_i} + \frac{P_i V}{RT_i} = \frac{P_f V}{RT_f} + \frac{P_f V}{RT_f}$$

$$2 \frac{P_i}{T_i} = \frac{P_f}{T_1} + \frac{P_f}{T_2} \Rightarrow P_f = \frac{2 P_i T_2}{T_1 + T_2}$$

**Section-A : JEE Advanced/ IIT-JEE**

- A** 1. isolated                      2. endothermic                      3. extensive
- B** 1. T                                      2. F
- C** 1. (a)                      2. (d)                      3. (b)                      4. (c)                      5. (a)                      6. (c)                      7. (b)                      8. (c)  
9. (b)                      10. (a)                      11. (b)                      12. (a)                      13. (b)                      14. (c)                      15. (b)                      16. (c)
- D** 1. (b, d)                      2. (b, c, d)                      3. (a, d)                      4. (a, b)                      5. (a, c)                      6. (a, c, d)                      7. (a, b, c)
- E** 1. 101.19 kcal                      2. 54.20 kcal                      4. 41.104 kcal  
5. -22 kcal                      6. -372.0 kcal/mole of ethane                      7. 3.94 kcal/cc                      8. 319.1 g  
9. -121 kJ/mole                      10. 82 kcal, 99 kcal                      11. 50.90 kJ                      12. -55.7 kJ/mole  
13.  $0.2803 \times l/hr, 5.461 \times l/hr$                       14. -72. kJ/mole                      15. -152 kJ/mole  
16. -266 kJ/mole                      17. ionic                      18. -2091.32 kJ                      19. 309.16 kJ  
20. -115.41 joules                      22. -2035 kJ/mole  
23. +15.992 kJ/mole, +12.312 kJ/mole -3.688 kJ/mole, B > C > A  
24. (ii) -6.13 L atm, 620.7 J, (iii) 0, 0, 0                      26. 9900 bar mL, 100 bar mL  
27. (i) -56.0304 L atm ; (ii) forward                      28. 557 kJ mol<sup>-1</sup>
- F** 1. A - p, r, s; B - r, s; C - t; D - p, q, t  
2. A - r, t; B - p, q, s; C - p, q, s; D - p, q, s, t
- G** 1. (c)                                      2. (b)
- H** 1. (b)                                      2. (a)
- I** 1. 9    2. 2

**Section-B : JEE Main/ AIEEE**

1. (b)                      2. (a)                      3. (d)                      4. (b)                      5. (c)                      6. (c)                      7. (a)  
8. (c)                      9. (b)                      10. (c)                      11. (d)                      12. (d)                      13. (b)                      14. (N)  
15. (c)                      16. (c)                      17. (a)                      18. (d)                      19. (a)                      20. (d)                      21. (b)  
22. (b)                      23. (c)                      24. (a)                      25. (b)                      26. (b)                      27. (a)                      28. (c)  
29. (a)                      30. (a)                      31. (b)

**Section-A JEE Advanced/ IIT-JEE****A. Fill in the Blanks**

1. **isolated**  
2. **endothermic**  
3. **extensive** (because its value does not depend on quantity of substance)

2. **False;**  $\frac{C_p}{C_v}$  for monoatomic gas = 1.66

$\frac{C_p}{C_v}$  for diatomic gas = 1.40

**B. True/False**

1. **True;** It only tells that if a process occurs the heat gained by one end would be exactly equal to heat lost by the other. It does not predict the direction.

**C. MCQs with One Correct Answer**

1. (a) **TIPS/Formulae :**

Heat capacity at constant volume ( $q_v$ ) =  $\Delta E$

Heat capacity of constant pressure ( $q_p$ ) =  $\Delta H$

$$\Delta H = \Delta E + \Delta nRT \text{ or } \Delta H - \Delta E = \Delta nRT$$

$$\begin{aligned} \Delta n &= \text{no. of moles of gaseous products} \\ &\quad - \text{no. of moles of gaseous reactants} \\ &= 12 - 15 = -3 \end{aligned}$$

$$\Delta H - \Delta E = -3 \times 8.314 \times 298 \text{ J} = -7.43 \text{ kJ.}$$

2. (d) **TIPS/Formulae :**

$$\Delta H = \Delta E + \Delta nRT \text{ For } \Delta H \neq \Delta E, \Delta n \neq 0$$

Where  $\Delta n$  = no. of moles of gaseous products – no. of moles of gaseous reactants

$$(a) \Delta n = 2 - 2 = 0$$

$$(b) \Delta n = 0 \quad (\because \text{they are either in solid or liquid state})$$

$$(c) \Delta n = 1 - 1 = 0 \quad (\because \text{C is in solid state})$$

$$(d) \Delta n = 2 - 4 = -2$$

$\therefore$  (d) is correct answer

3. (b)  $\text{CO}_2(\text{g}) + \text{H}_2(\text{g}) \longrightarrow \text{CO}(\text{g}) + \text{H}_2\text{O}(\text{g}), \Delta H = ?$

$$\Delta H = \sum \Delta H_f(\text{Product}) - \sum \Delta H_f(\text{reactant})$$

$$\text{Given, } \Delta H_f \text{CO}_2(\text{g}) = -393.5 \text{ kJ/mol}$$

$$\Delta H_f \text{CO}(\text{g}) = -110.5 \text{ kJ/mol}$$

$$\Delta H_f \text{H}_2\text{O}(\text{g}) = -241.8 \text{ kJ/mol}$$

$$\begin{aligned} \therefore \Delta H &= [\Delta H_f \text{CO}(\text{g}) + \Delta H_f \text{H}_2\text{O}(\text{g})] \\ &\quad - [\Delta H_f \text{CO}_2(\text{g}) + \Delta H_f \text{H}_2(\text{g})] \\ &= [-110.5 + (-241.8)] - (-393.5 + 0) \end{aligned}$$

$$\left[ \because \Delta H_f(\text{H}_2)_g = 0 \right]$$

$$= 41.2 \text{ kJ mol}^{-1}$$

4. (c) In a reversible process, the driving and the opposite forces are nearly equal, hence the system and the surroundings always remain in equilibrium with each other.

5. (a) Work is not a state function because it depends upon the path followed.

6. (c) **TIPS/Formulae :**

$$\Delta H = \Delta U + P_2V_2 - P_1V_1 \text{ Given, } \Delta U = 30.0 \text{ L atm}$$

$$P_1 = 2.0 \text{ atm, } V_1 = 3.0 \text{ L, } T_1 = 95 \text{ K}$$

$$P_2 = 4.0 \text{ atm, } V_2 = 5.0 \text{ L, } T_2 = 245 \text{ K}$$

$$\begin{aligned} \Delta H &= \Delta U + P_2V_2 - P_1V_1 \\ &= 30 + (4 \times 5) - (2 \times 3) = 30 + 20 - 6 = 44 \text{ L atm.} \end{aligned}$$

7. (b) **TIPS/Formulae :**

$\Delta H_f^\circ$  is the enthalpy change when 1 mole of the substance is formed from its elements in their standard states.

In (a) carbon is present in diamond however standard state of carbon is graphite. Again, in (d) CO (g) is involved so it can't be the right option. Further in (c) 2

moles of  $\text{NH}_3$  are generated. Hence the correct option is (b).

8. (c)  $\Delta H = nC_p \Delta T$  solution; since  $\Delta T = 0$  so,  $\Delta H = 0$

$$9. (b) \Delta S = \frac{\Delta Q_{\text{rev}}}{T}; 75 = \frac{30 \times 10^3}{T} \therefore T = 400 \text{ K}$$

$$10. (a) \Delta S_{(A \rightarrow B)} = \Delta S_{(A \rightarrow C)} + \Delta S_{(C \rightarrow D)} - \Delta S_{(B \rightarrow D)} \\ = 50 + 30 - 20 = 60 \text{ e.u.}$$

11. (b)  $A \rightleftharpoons B$

$$\Delta G^\circ = \Delta H^\circ - T\Delta S^\circ, \Delta G^\circ = -2.303 RT \log_{10} K$$

$$-2.303 RT \log_{10} K = \Delta H^\circ - T\Delta S^\circ$$

$$2.303 RT \log_{10} K = T\Delta S^\circ - \Delta H^\circ$$

$$\log_{10} K = \frac{T\Delta S^\circ - \Delta H^\circ}{2.303RT} = \frac{298 \times 10 + 54.07 \times 1000}{2.303 \times 8.314 \times 298} = 10$$

12. (a) Since, liquid is passing into gaseous phase so entropy will increase and at 373 K during the phase transformation it remains at equilibrium. So,  $\Delta G = 0$ .

13. (b) The species in its elemental form has zero standard molar enthalpy of formation at 298 K. At 298K,  $\text{Cl}_2$  is gas while  $\text{Br}_2$  is liquid.

14. (c) The standard enthalpy of the combustion of glucose can be calculated by the eqn.

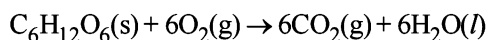

$$\Delta H_c = 6 \times \Delta H_f(\text{CO}_2) + 6 \times \Delta H_f(\text{H}_2\text{O}) - \Delta H_f[\text{C}_6\text{H}_{12}\text{O}_6]$$

$$\Delta H^\circ = 6(-400) + 6(-300) - (-1300) = -2900 \text{ kJ/mol}$$

For one gram of glucose, enthalpy of combustion

$$\Delta H^\circ = -\frac{2900}{180} = -16.11 \text{ kJ/gm}$$

15. (b) Given conditions are boiling conditions for water due to which

$$\Delta S_{\text{total}} = 0$$

$$\Delta S_{\text{system}} + \Delta S_{\text{surroundings}} = 0$$

$$\Delta S_{\text{system}} = -\Delta S_{\text{surroundings}}$$

$$\text{For process, } \Delta S_{\text{system}} > 0$$

$$\Delta S_{\text{surroundings}} < 0$$

16. (c) From 1<sup>st</sup> law of thermodynamics

$$q_{\text{sys}} = \Delta U - w = 0 - [-P_{\text{ext}} \Delta V]$$

$$= 3.0 \text{ atm} \times (2.0 \text{ L} - 1.0 \text{ L}) = 3.0 \text{ L-atm}$$

$$\therefore \Delta S_{\text{surr}} = \frac{(q_{\text{rev}})_{\text{surr}}}{T} = -\frac{q_{\text{sys}}}{T}$$

$$= -\frac{3.0 \times 101.3 \text{ J}}{300 \text{ K}} = -1.013 \text{ J/K}$$

#### D. MCQs with One or More Than One Correct

1. (b, d) Properties independent of mass are intensive properties. Hence (b) and (d) which are independent of mass are the obvious choices.



## Thermodynamics

- (b, c, d) All combustion reactions are exothermic in nature.
- (a, d) Internal energy and molar enthalpy are state functions. Work (reversible or irreversible) is a path function.
- (a, b) Mass independent properties (molar conductivity and electromotive force) are intensive properties. Resistance and heat capacity are mass dependent, hence extensive properties.
- (a, c)  $\Delta S_{x \rightarrow z} = \Delta S_{x \rightarrow y} + \Delta S_{y \rightarrow z}$  [Entropy is a state function, hence additive]  
 $W_{x \rightarrow y \rightarrow z} = W_{x \rightarrow y}$  [Work done in  $y \rightarrow z$ , is zero because it is an isochoric process].
- (a, c, d)  $T_1 = T_2$  because process is isothermal.  
 Work done in adiabatic process is less than in isothermal process because area covered by isothermal curve is more than the area covered by the adiabatic curve.  
 In adiabatic process expansion occurs by using internal energy, hence, it decreases while in isothermal process temperature remains constant that's why no change in internal energy.
- (a, b, c) Since the vessel is thermally insulated,  $q = 0$   
 Further since,  $P_{\text{ext}} = 0$ , so  $w = 0$ , hence  $\Delta U = 0$   
 Since  $\Delta T = 0$ ,  $T_2 = T_1$ , and  $P_2 V_2 = P_1 V_1$   
 However, the process is adiabatic irreversible, so we can't apply  $P_2 V_2^\gamma = P_1 V_1^\gamma$ .

### E. Subjective Problems

- The required reaction in terms of dissociation energy is  $\text{OH}(g) \rightarrow \text{O}(g) + \text{H}(g)$ ;  $\Delta H = ?$   
 This equation can be achieved by (a) reversing the equation (i), (b) dividing equation (ii) and (iii) each by 2, and (c) adding the three resulting equations.

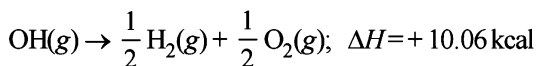

[Reversing eq (i)]

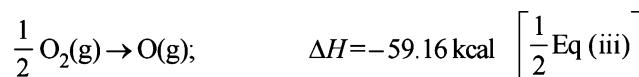
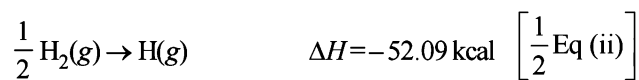

Thus one mole of  $\text{OH}(g)$  needs 101.19 kcal of energy to break into oxygen and hydrogen gaseous atoms. Hence the bond energy of O-H bond is **101.19 kcal**.

- The required equation is :

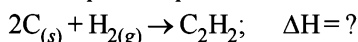

Write the thermochemical equations for the given data

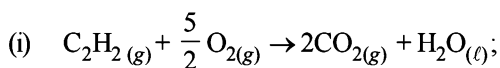

$$\Delta H = -310.62 \text{ kcal}$$

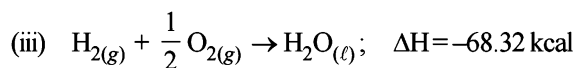
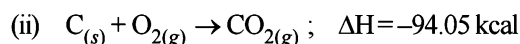

For getting the above required reaction, we will have to

**NOTE :**

- Bring  $\text{C}_2\text{H}_2$  in the product that can be done by reversing the equation (i) to give equation (iv).
- Multiply equation (ii) by 2 to get 2C atoms in the reactants and thus equation (v) is obtained.
- Keep equation (iii) as such.
- Add equations (iv), (v) and (iii).

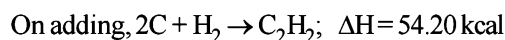
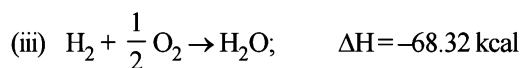
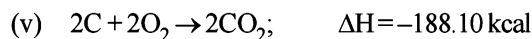
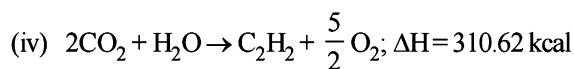

Hence the standard heat of formation of  $\text{C}_2\text{H}_2(g)$  = **54.20 kcal**

- If heat is absorbed at constant pressure, then  $q_p = \Delta E - (-P\Delta V)$  or  $q_p = E_2 - E_1 - [-P(V_2 - V_1)]$  or  $q_p = (E_2 + PV_2) - (E_1 + PV_1) = H_2 - H_1 = \Delta H$
- The given data can be written as follows

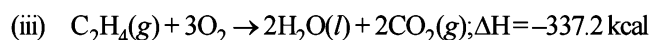
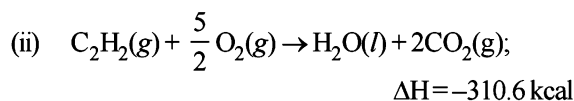
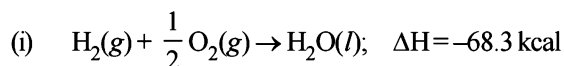

The required thermochemical equation is

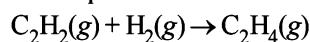

The required equation can be obtained by subtracting equation (iii) from the sum of equations (i) and (ii), thus  $\Delta H$  of the required equation can be calculated as below.

$$\begin{aligned} \Delta H &= [-68.3 + (-310.6)] - (-337.2) \\ &= [-68.3 - 310.6] + 337.2 \\ &= -378.9 + 337.2 = -41.7 \text{ kcal} \end{aligned}$$

$\Delta E$ , the heat of reaction for the hydrogenation of acetylene at constant volume is given by :

$$\Delta E = \Delta H - \Delta nRT$$

Here  $\Delta n$  = Moles of the gaseous products - Moles of the gaseous reactants

$$= 1 - (1 + 1) = -1$$

Substituting the values of  $\Delta H$ ,  $\Delta n$ , R and T in

$$\Delta E = \Delta H - \Delta nRT = -41.7 - (-1 \times 2 \times 10^{-3} \times 298)$$

$$\left[ \begin{aligned} \because R &= 2 \text{ cal/degree/mole} \\ &= 2 \times 10^{-3} \text{ kcal/deg/mole} \end{aligned} \right]$$

$$= -41.7 + 2 \times 10^{-3} \times 298$$

$$= -41.7 + 0.596 = \mathbf{41.104 \text{ kcal}}$$

5. Bond	H-H	Cl-Cl	H-Cl
$\Delta H$ disso.	104 kcal	58 kcal	103 kcal

Formation of hydrogen chloride can be represented as  
 $H-H + Cl-Cl \rightarrow 2H-Cl$

Thus the reaction involves

Cleavage of one H-H bond,  $\Delta H = 104$  kcal

Cleavage of one Cl-Cl bond,  $\Delta H = 58$  kcal

Formation of two H-Cl bonds,  $\Delta H = 2 \times 103$  kcal

$$\therefore \Delta H \text{ of the reaction} = (104 + 58) - 2(103) \\ = 162 - 206 = -44 \text{ kcal}$$

Now since the enthalpy of formation of a compound is the change in heat content accompanied in the formation of one mole of the compound, the enthalpy of formation of

$$HCl \text{ gas} = -\frac{44}{2} = -22 \text{ kcal}$$

6. The required chemical reaction.



Note that since 2 moles of ethane are reacting, the  $\Delta H$  of the reaction will be  $\frac{1}{2}x$ .

The thermochemical equations for the given data are written as below.

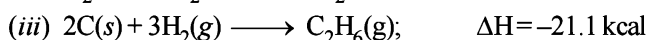
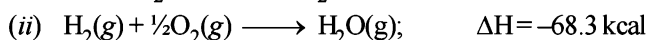
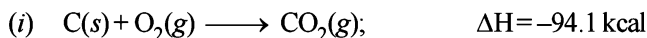

We know that  $\Delta H = H_{\text{Products}} - H_{\text{Reactants}}$

$$\Delta H = 4\Delta H_{CO_2} + 6\Delta H_{H_2O} - (2\Delta H_{C_2H_6} + 7\Delta H_{O_2})$$

$$\Delta H = 4 \times -94.1 + 6 \times -68.3 - (2 \times -21.1 + 0) \\ = -376.4 - 409.8 + 42.2 = -744.0 \text{ kcal/2 mole of ethane} \\ = -372.0 \text{ kcal/mole of ethane}$$

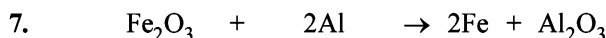

$$2 \times 56 + 48 = 160 \quad 2 \times 27 = 54$$

Heat of reaction =  $399 - 199 = 200$  kcal [Al & Fe are in their standard states]

Total weight of reactants =  $160 + 54 = 214$  g

$$\therefore \text{Fuel value/gram} = \frac{200}{214} = 0.9346 \text{ kcal/g}$$

$$\text{Volume of Al} = \frac{54}{2.7} = 20 \text{ cc}$$

$$\text{Volume of } Fe_2O_3 = \frac{160}{5.2} = 30.77 \text{ cc}$$

Total volume =  $20 + 30.77 = 50.77$  cc

$$\therefore \text{Fuel value per cc} = \frac{200}{50.77} = 3.94 \text{ kcal/cc}$$

8. 100 g of glucose = 1560 kJ

$$\text{Energy utilised in body} = \frac{50}{100} \times 1560 = 780 \text{ kJ}$$

Energy left unutilised in body =  $1560 - 780 = 780$  kJ

Energy to be given out =  $1560 - 780 = 780$  kJ

Enthalpy of evaporation of water = 44 kJ/mole = 44 kJ/18 g of water [1 mole  $H_2O = 18$  g water]

Hence amount water to be perspired to avoid storage of

$$\text{energy} = \frac{18}{44} \times 780 = 319.1 \text{ g}$$

9. The required reaction is

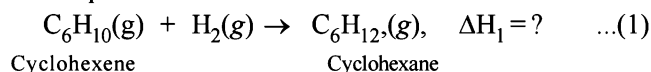

The given facts can be written as :

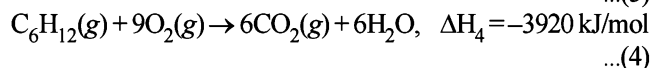
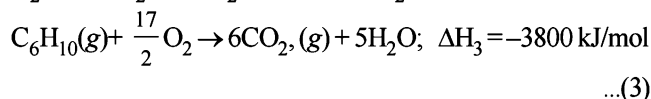

The required reaction (1) can be obtained by adding equations (2) and (3) and subtracting (4) from the sum of (2) and (3).

$$C_6H_{10}(g) + H_2(g) \rightarrow C_6H_{12}(g) \\ \Delta H_1 = (\Delta H_2 + \Delta H_3) - \Delta H_4 \\ = [-241 + (-3800)] - (-3920) \\ = (-241 - 3800) - (-3920) \\ = -4041 + 3920 = -121 \text{ kJ/mole}$$

10. For  $C_3H_8$ :  $3C + 4H_2 \rightarrow C_3H_8$ ;  $\Delta H_1 = ?$

For  $C_2H_6$ :  $2C + 3H_2 \rightarrow C_2H_6$ ;  $\Delta H_2 = ?$

$$\therefore \Delta H_1 = -[2(C-C) + 8(C-H)] + [3C_{s \rightarrow g} + 4(H-H)] \quad \dots(1)$$

$$\therefore \Delta H_2 = -[1(C-C) + 6(C-H)] + [2C_{s \rightarrow g} + 3(H-H)] \quad \dots(2)$$

Let bond energy of C-C be  $x$  kcal and bond energy of C-H be  $y$  kcal

$$\therefore \text{By eq. (1)} \Delta H_1 = -(2x + 8y) + [3 \times 172 + 4 \times 104] \quad \dots(3)$$

$$\Delta H_2 = -(x + 6y) + [2 \times 172 + 3 \times 104] \quad \dots(4)$$

Also given  $C + O_2 \rightarrow CO_2$ ;  $\Delta H = -94.0$  kcal  $\dots(5)$

$H_2 + \frac{1}{2}O_2 \rightarrow H_2O$ ;  $\Delta H = -68.0$  kcal  $\dots(6)$

$C_2H_6 + (7/2)O_2 \rightarrow 2CO_2 + 3H_2O$ ;  $\Delta H = -372$  kcal  $\dots(7)$

$C_3H_8 + 5O_2 \rightarrow 3CO_2 + 4H_2O$ ;  $\Delta H = -530$  kcal  $\dots(8)$

By inspection method :  $2 \times (5) + 3 \times (6) - (7)$  gives

$$2C + 3H_2 \rightarrow C_2H_6; \quad \Delta H_2 = -20 \text{ kcal} \quad \dots(9)$$

and  $3 \times (5) + 4 \times (6) - (8)$  gives

$$3C + 4H_2 \rightarrow C_3H_8; \quad \Delta H_1 = -20 \text{ kcal} \quad \dots(10)$$

$\therefore$  By eq. (3), (4), (9) and (10)

$$x + 6y = 676$$

$$2x + 8y = 956$$

$\therefore x = 82$  kcal and  $y = 99$  kcal

Bond energy of C-C bond = **82 kcal**

and Bond energy of C-H bond = **99 kcal**

11. Combustion of  $C_2H_4$  and  $CH_4$  takes place as follows :

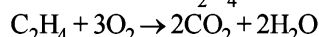

1 vol. 2 vol.

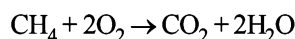

1 vol. 1 vol.

Let the vol. of  $CH_4$  in mixture =  $x$  l

$\therefore$  Vol. of  $C_2H_4$  in the mixture =  $(3.67 - x)$  l

Vol. of  $\text{CO}_2$  produced by  $x$  l of  $\text{CH}_4 = x$  l and  
 Vol. of  $\text{CO}_2$  produced by  $(3.67 - x)$  l of  $\text{C}_2\text{H}_4 = 2(3.67 - x)$  l  
 $\therefore$  Total vol. of  $\text{CO}_2$  produced  $= x + 2(3.67 - x)$   
 or  $6.11 = x + 2(3.67 - x)$  or  $x = 1.23$  l  
 $\therefore$  Vol. of  $\text{CH}_4$  in the mixture  $= 1.23$  l  
 and Vol. of  $\text{C}_2\text{H}_4$  in the mixture  $= 3.67 - 1.23 = 2.44$  l

Vol. of  $\text{CH}_4$  per litre of the mixture  $= \frac{1.23}{3.67} = 0.335$  l

Vol. of  $\text{C}_2\text{H}_4$  per litre of the mixture  $= \frac{2.44}{3.67} = 0.665$  l

Now we know that volume of 1 mol. of any gas at

$$25^\circ\text{C} (298 \text{ K}) = \frac{22.4 \times 298}{273} = 24.45 \text{ l}$$

[ $\therefore$  Volume at NTP = 22.4 L]

Heat evolved due to combustion of 0.335 l of  $\text{CH}_4$

$$= -\frac{0.335 \times 891}{24.45} = -12.20 \text{ kJ} \quad [\text{given, heat evolved by}$$

combustion of 1 l = 891 kJ]

Similarly, heat evolved due to combustion of 0.665 l of  $\text{C}_2\text{H}_4$

$$= -\frac{0.665 \times 1423}{24.45} = -38.70 \text{ kJ}$$

$\therefore$  Total heat evolved  $= 12.20 + 38.70 = 50.90 \text{ kJ}$

12. From the given data, we can write :

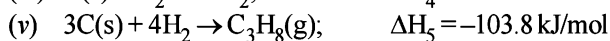
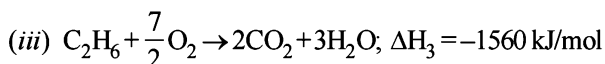
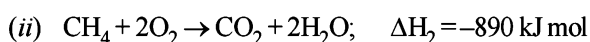

The required reaction is  $\text{C}_3\text{H}_8(\text{g}) + \text{H}_2(\text{g}) \rightarrow \text{C}_2\text{H}_6(\text{g}) + \text{CH}_4(\text{g}), \Delta H = ?$

It can be obtained by the following calculations.

$$3 \times (\text{iv}) - (\text{v}) + 5(\text{i}) - (\text{iii}) - (\text{ii})$$

In other words,  $\Delta H = 3\Delta H_4 - \Delta H_5 + 5\Delta H_1 - \Delta H_2 - \Delta H_3$

$$\therefore \Delta H = 3(-393.5) - (-103.8) + 5(-285.8) + 890 + 1560$$

$$= -2609.5 + 2553.8 = -55.7 \text{ kJ/mol}$$

13. Combustion of  $\text{CH}_4$  and  $\text{C}_4\text{H}_{10}$  takes place as follows

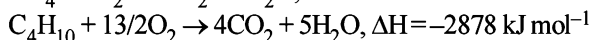
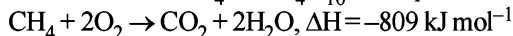

In order to get the same calorific output due to  $\text{C}_4\text{H}_{10}$ ,

$$\text{the rate of supply of butane} = \frac{x \times 809}{2878} = 0.281 x \text{ l/hr}$$

$$\text{Rate of supply of oxygen} = 0.2803 x \times \frac{13}{2} \times 3 = 5.481 x \text{ l/hr}$$

14.  $n\text{CH}_2 = \text{CH}_2 \rightarrow (\text{CH}_2 - \text{CH}_2)_n$

**NOTE :** During the polymerisation of ethylene, one mole of ethylene breaks i.e. one  $\text{C} = \text{C}$  double bond breaks and the two  $\text{CH}_2 -$  groups are linked with  $\text{C} - \text{C}$  single bonds thus forming three single bonds (two single bonds are formed when each  $\text{CH}_2 -$  group of ethylene links with one  $\text{CH}_2 -$  group of another ethylene molecule). But in the whole unit

of polymer, number of single  $\text{C}-\text{C}$  bonds formed/mole of ethylene is 2.

Energy released = Energy due to formation of 2  $\text{C}-\text{C}$  single bonds

$$= 2 \times 331 = 662 \text{ kJ/mol of ethylene}$$

Energy absorbed = Energy due to dissociation of 1  $\text{C}=\text{C}$  double bond

$$= 590 \text{ kJ/mol of ethylene}$$

$\therefore$  Enthalpy of polymerisation/mol of ethylene or  $\Delta H_{\text{polymerisation}} = 590 - 662 \text{ kJ/mol} = -72 \text{ kJ/mol}$

15. Standard enthalpy of hydrogenation of cyclohexene ( $-119 \text{ kJ mol}^{-1}$ ) means the enthalpy of hydrogenation of one  $\text{C} = \text{C}$  double bond. Now benzene has three  $\text{C} = \text{C}$  double bonds, the enthalpy of the reaction would be  $3 \times -119 = -357 \text{ kJ mol}^{-1}$

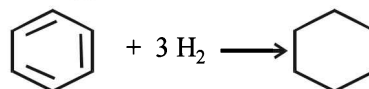

Actual enthalpy of the reaction can be evaluated as follows.

$$\Delta H_{\text{(Reaction)}} = \Delta H_f^\circ(\text{Product}) - \Delta H_f^\circ(\text{Reactants})$$

$$= -156 - (49 + 0) = -205 \text{ kJ mol}^{-1}$$

$$\therefore \text{Resonance energy} = \Delta H_{\text{Exp}} - \Delta H_{\text{cal}}$$

$$= -357 - (-205) = -152 \text{ kJ mol}^{-1}$$

16. The required thermochemical equation is

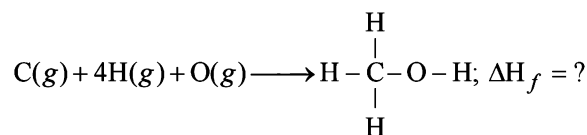

$$\begin{aligned} \Delta H_f &= \left[ \Delta H_{\text{C(s)} \rightarrow \text{C(g)}} + 2\Delta H_{\text{H-H}} + \frac{1}{2} \Delta H_{\text{O=O}} \right] \\ &\quad - \left[ 3\Delta H_{\text{C-H}} + \Delta H_{\text{C-O}} + \Delta H_{\text{O-H}} + \Delta H_{\text{vap. CH}_3\text{OH}} \right] \\ &= [715 + 2 \times 436 + 249] - [3 \times 415 + 356 + 463 + 38] \\ &= -266 \text{ kJ mol}^{-1} \end{aligned}$$

17. **TIPS/Formulae :**

For ionisation  $\Delta H_{\text{ionisation}} > \Delta H_{\text{Hydration}}$

Total hydration energy of  $\text{Al}^{3+}$  &  $3\text{Cl}^-$  ions of  $\text{AlCl}_3$  ( $\Delta H_{\text{hydration}}$ )

$= (\text{Hydration energy of } \text{Al}^{3+} + 3 \times \text{Hydration energy of } \text{Cl}^-)$

$$= [-4665 + 3(-381)] \text{ kJ mole}^{-1} = -5808 \text{ kJ mole}^{-1}$$

**NOTE :** This amount of energy is more than that required for the ionisation of Al into  $\text{Al}^{3+}$  (Ionisation energy of Al to  $\text{Al}^{3+} = 5137 \text{ kJ mol}^{-1}$ ). Due to this reason,  $\text{AlCl}_3$  becomes ionic in aqueous solution. In aqueous solution it exists in ionic form as below

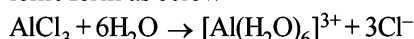

$\Delta H =$  Energy released during hydration

$-$  Energy used during ionisation

$$= -4665 - 3 \times 381 + 5137 = -671 \text{ kJ/mol}$$

Thus formation of ions will take place.

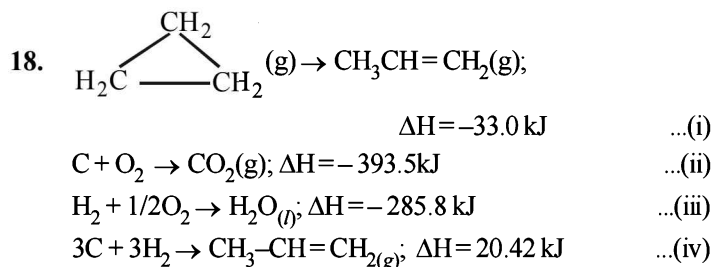

The required reaction is

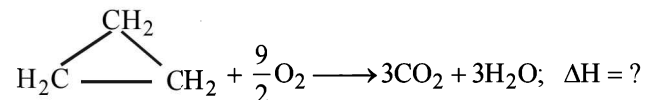

To calculate the value of  $\Delta H$  follow the following steps.

(iv) – (i) yields

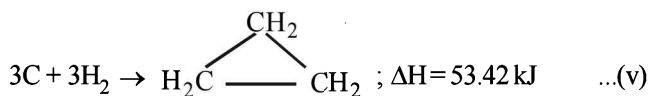

$[3 \times (\text{ii}) + 3 \times (\text{iii})] - (\text{v})$  yields

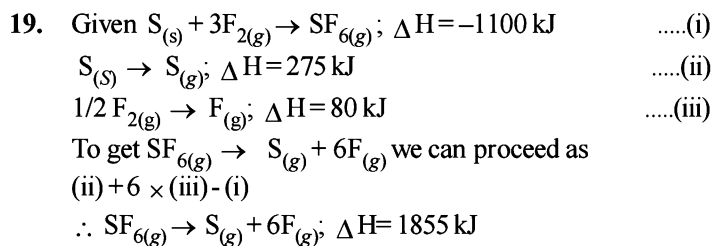
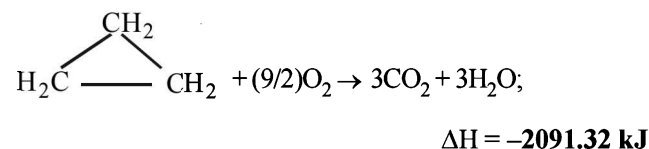

Thus average bond energy for S-F bond =  $\frac{1855}{6} = 309.16 \text{ kJ}$

20. TIPS/Formulae : For adiabatic expansion, we have

$$\ln \frac{T_1}{T_2} = \frac{R}{C_v} \ln \frac{V_2}{V_1} \text{ and } \Delta H = nC_p \Delta T.$$

$$\ln \frac{300}{T_2} = \frac{8.31}{12.48} \ln \frac{2.50}{1.25} \text{ Solving, we get, } T_2 = 188.5 \text{ K}$$

$$\text{No. of moles of argon gas, } n = \frac{PV}{RT} = \frac{1 \times 1.25}{0.082 \times 300} = 0.05$$

Now we know that

$$\Delta H = nC_p \Delta T = 0.05 \times 20.8(188.5 - 300) = -115.41 \text{ Joules}$$

$$[\because C_p = C_v + R = 12.48 + 8.314 = 20.8]$$

21. For following reaction

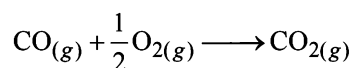

$\Delta G^\circ$  can be calculated as follows :

$$\begin{aligned} \Delta G^\circ &= \Delta G_p^\circ - \Delta G_R^\circ = \left[ \Delta G^\circ \text{CO}_2 - \left( \Delta G^\circ \text{CO} + \frac{1}{2} \Delta G^\circ \text{O}_2 \right) \right] \\ &= -394.4 - (-137.2 + \frac{1}{2} \times 0) = -257.2 \text{ kJ mol}^{-1} \end{aligned}$$

Since,

$$\Delta G^\circ = \Delta H^\circ - T\Delta S^\circ \text{ or } -257.2 = \Delta H - 300(0.094)$$

$$\therefore \Delta H^\circ = -285.4 \text{ kJ/mol}$$

Since,

NOTE :  $\therefore \Delta H^\circ$  is negative, so the reaction is exothermic and since  $\Delta G^\circ$  is negative so the reaction is spontaneous.

22. The chemical reaction for combustion of diborane is

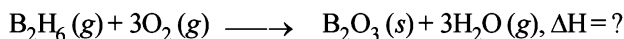

For this the enthalpy change can be calculated in the following way.

$$\Delta H = [\Delta H_{\text{B}_2\text{O}_3(\text{s})} + 3\Delta H_{\text{H}_2\text{O}(\text{g})}] - \Delta H_{\text{B}_2\text{H}_6(\text{g})};$$

$(\because \Delta H_f^\circ \text{ of } \text{O}_2 = 0)$

$\Delta H_{\text{H}_2\text{O}(\text{g})}$  can be obtained by adding  $\Delta H_{\text{H}_2\text{O}(\text{l})}$  and

$$\Delta H_{\text{H}_2\text{O}(\text{g})}, \text{ i.e. } -286 + 44 = -242 \text{ kJ mol}^{-1}$$

$$\Delta H = [-1273 + 3 \times -242] - 36 \text{ kJ mol}^{-1} = -1273 - 726 - 36 = -2035 \text{ kJ mol}^{-1}$$

23. TIPS/Formulae :

$$\Delta G^\circ = -2.303RT \log \frac{[\text{Product}]}{[\text{Reactant}]}$$

Calculation of  $\Delta G$  values :

Thus for the equilibrium  $\text{B} \rightleftharpoons \text{A}$

$$\Delta G_1^\circ = (-2.303 \times 8.314 \times 448) \log \frac{1.3}{95.2}$$

$$\text{or } \Delta G_1^\circ = 15.992 \text{ kJ mole}^{-1}$$

Similarly for the equilibrium  $\text{B} \rightleftharpoons \text{C}$

$$\Delta G_2^\circ = (-2.303 \times 8.314 \times 448) \log \frac{3.5}{95.2}$$

$$\text{or } \Delta G_2^\circ = 12.312 \text{ kJ mole}^{-1}$$

Similarly for equilibrium,  $\text{A} \rightleftharpoons \text{C}$

$$\Delta G_3^\circ = -8.314 \times 448 \times 2.303 \times \log_{10} \frac{3.5}{1.3} = -3.688 \text{ kJ mole}^{-1}$$

Hence, we have that

$$\text{B} \rightleftharpoons \text{A}, \Delta G_1^\circ = +15.992 \text{ kJ mole}^{-1}$$

$$\text{B} \rightleftharpoons \text{C}, \Delta G_2^\circ = +12.312 \text{ kJ mole}^{-1}$$

$$\text{A} \rightleftharpoons \text{C}, \Delta G_3^\circ = -3.688 \text{ kJ mole}^{-1}$$

Thus, the correct order of stability,  $\text{B} > \text{C} > \text{A}$

**NOTE :** Mechanism of isomerisation

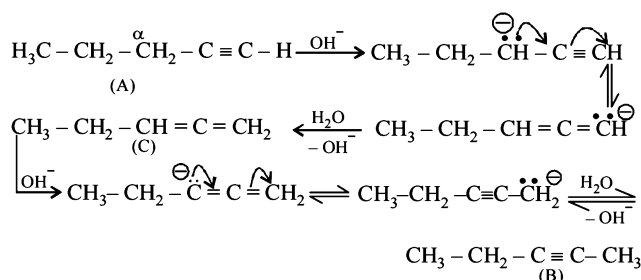

24. (i)

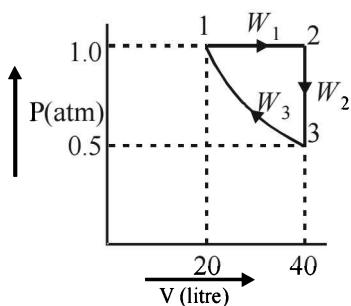

(ii) Total work ( $W$ ) =  $W_1 + W_2 + W_3$

$$\begin{aligned}
 &= -P\Delta V + 0 + 2.303nRT \log \frac{V_2}{V_1} \\
 &= -1 \times 20 + 2.303 \times 2 \times 0.082 \times 121.95 \log 2 \\
 &= -20 + 13.87 = -6.13 \text{ L atm}
 \end{aligned}$$

$$\left[ \begin{array}{l} PV = nRT \\ T = \frac{PV}{nR} = \frac{.5 \times 40}{2 \times 0.082} \end{array} \right] = 121.95 \text{ K}$$

Since the system has returned to its initial state i.e. the process is cyclic, so  $\Delta U = 0$

$$\Delta U = q + W = 0, \text{ so } q = -W = -(-6.13) \text{ L atm} = 620.7 \text{ J}$$

**NOTE :** In a cyclic process heat absorbed is completely converted into work.

(iii) Entropy is a state function and since the system has returned to its initial state, so  $\Delta S = 0$ . Similarly  $\Delta H = 0$  and  $\Delta U = 0$  for the same reason i.e.  $U$  and  $H$  are also state functions having definite values in a given state of a system.

25. Helium molecule is monoatomic so it has just three degrees of freedom corresponding to the three translational motion at all temperature and hence  $C_v$  value is always  $3/2 R$ . Hydrogen molecule is diatomic which are not rigidly held so they vibrate about a well defined average separation. For hydrogen molecule we have rotational and vibrational motion both besides translational motion. These two additional contributions increase its total heat capacity. Contribution from vibrational motion is not appreciable at low temperature but increases from 0 to  $R$  on raising temperature.

26. **TIPS/Formulae :** For adiabatic process,  $W = P(V_2 - V_1)$

Here  $P_1 = 1 \text{ bar}$ ,  $P_2 = 100 \text{ bar}$ ,  $V_1 = 100 \text{ mL}$ ,  $V_2 = 99 \text{ mL}$ ; For adiabatic process,  $q = 0 \Rightarrow \Delta U = w$

$$\Delta U = q + W = q - P(V_2 - V_1) \text{ since } W = -P(V_2 - V_1)$$

$$= 0 - 100(99 - 100) = 100 \text{ bar mL}$$

$$\Delta H = \Delta U + \Delta(PV) = \Delta U + (P_2V_2 - P_1V_1)$$

$$= 100 + [(100 \times 99) - (1 \times 100)]$$

$$= 100 + (9900 - 100) = 9900 \text{ bar mL}$$

27. (i)  $\text{N}_2\text{O}_4(\text{g}) \rightleftharpoons 2\text{NO}_2(\text{g})$

Initially  $P_{\text{N}_2\text{O}_4} = P_{\text{NO}_2} = 10$

$$\text{Reaction quotient} = \frac{(P_{\text{NO}_2})^2}{P_{\text{N}_2\text{O}_4}} = \frac{100}{10} = 10$$

$$\Delta G^\circ = 2\Delta G_f^\circ(\text{NO}_2) - \Delta G_f^\circ(\text{N}_2\text{O}_4) = 100 - 100 = 0$$

$$\Delta G = \Delta G^\circ - 2.303 RT \log K_p$$

$$= 0 - 2.303 \times 298 \log 10 = -56.0304 \text{ L atm.}$$

(ii) The negative value of  $\Delta G$  indicates that the reaction is spontaneous & will lie in the right direction, (forward).

28.  $\Delta H = \Delta U + \Delta(PV) = \Delta U + V\Delta P$  ( $\because \Delta V = 0$ )

$$\text{or } \Delta U = \Delta H - V\Delta P = -560 - [1(40 - 70) \times 0.1]$$

$$= -560 + 3 = -557 \text{ kJ mol}^{-1}$$

So the magnitude is  $557 \text{ kJ mol}^{-1}$ .

$$\because \Delta G^\circ = -2.303RT \log K_p \text{ at equilibrium } \Delta G^\circ = 0$$

$$\therefore -2.303RT \log K_p = 0 \Rightarrow \log K_p = 0 \text{ or } K_p = 1$$

### F. Match the Following

1. **A - p, r, s ; B - r, s ; C - t ; D - p, q, t**

(A)  $\text{CO}_2(\text{s}) \rightarrow \text{CO}_2(\text{g})$

It is phase transition. The process is endothermic (sublimation). Gas is produced, so entropy increases.

(B) On heating  $\text{CaCO}_3$  decomposes. So, process is endothermic.

The entropy increases as gaseous product is formed.

(C)  $2\text{H}^\bullet \rightarrow \text{H}_2(\text{g})$

Entropy decreases as number of gaseous particles decreases.

(D) It is phase transition.

White and red P are allotropes.

Red P is more stable than white.

So  $\Delta H$  is -ve.

2. **A - (r, t); B - (p, q, s); C - (p, q, s); D - (p, q, s, t)**

(A)  $\rightarrow r, t$

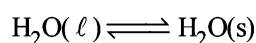

It is at equilibrium at 273 K and 1 atm

So  $\Delta S_{\text{sys}}$  is negative

As it is equilibrium process so  $\Delta G = 0$

(B) → p, q, s

Expansion of 1 mole of an ideal gas in vacuum under isolated condition

Hence,  $w = 0$ and  $q_p = C_p dT$  ( $\because dT = 0$ )⇒  $q = 0$  $\Delta U = C_v dT$  ( $\because dT = 0$ )  $\Delta U = 0$ 

(C) → p, q, s

Mixing of two ideal gases at constant temperature

Hence,  $\Delta T = 0$ ∴  $q = 0$ ;  $\Delta U = 0$ also  $w = 0$  ( $\Delta U = q + w$ )

(D) → p, q, s, t

Reversible heating and cooling of gas follows same path also initial and final position is same.

Hence,  $q = 0$   
 $w = 0$  } Path same $\Delta U = 0$   
 $\Delta G = 0$  } State function**G. Comprehension Based Questions**

1. (c) Pressure

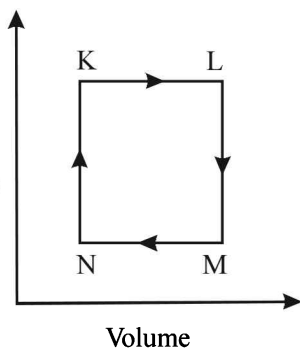
 $K \rightarrow L \Rightarrow V$  increasing at constant P

Hence T increases (Heating)

 $L \rightarrow M \Rightarrow P$  decreasing at constant V

Hence T decreases (Cooling)

 $M \rightarrow N \Rightarrow V$  decreasing at constant P

Hence T decreases (Cooling)

 $N \rightarrow K \Rightarrow P$  increasing at constant V

Hence T increases (Heating)

2. (b) L to M and N to K, both are having constant volume therefore these processes are isochoric.

**H. Assertion & Reason Type Questions**

1. (b) By first law of thermodynamics  $dq = dE + dW$ . Under isothermal condition for ideal gas  $dW = 0$  as volume occupied by the molecules of ideal gas is zero. Also  $(dE)_T = 0$  as for ideal gas there is no change in internal energy at constant T due to no force of attraction between the molecules. ∴  $dq = 0 + 0 = 0$ .
2. (a) Statement 1 is true because it is not possible to convert whole of heat to work. For such a conversion we need an efficiency of 100% but so far we have not been able to get such a machine (Carnot engine).  
Statement 2 is true because it is not possible to convert the whole of heat absorbed from a reservoir into work. Some of the heat is always given to the sink.  
Also statement 2 is correct explanation for statement 1.  
Thus the correct choice is option (a).

**I. Integer Value Correct Type**

1. Energy released by combustion of 3.5 g gas  
 $= 2.5 \times (298.45 - 298) \text{ kJ}$   
 Energy released by 1 mole of gas  $= \frac{2.5 \times 0.45}{3.5/28} = 9 \text{ kJ mol}^{-1}$
2.  $w_d = \left(-4 \times \frac{3}{2}\right) + (-1 \times 1) + \left(-\frac{2}{3} \times \frac{5}{2}\right) = -\left(6 + 1 + \frac{5}{3}\right)$   
 $w_d = -\frac{26}{3} \text{ L atm}$   
 $w_s = -2.303 RT \log \frac{5.5}{1/2} = -2.303 PV \log 11$   
 $w_s = -4.606 \times 1.04 = -4.8 \text{ L atm}$   
 $\frac{w_d}{w_s} = \frac{-\frac{26}{3}}{-4.8} = 1.80 = 2.0$

## Section-B

## JEE Main/ AIEEE

1. (b) TIPS/Formulae :

$$\Delta G = \Delta H - T\Delta S$$

Since  $\Delta G = \Delta H - T\Delta S$  for an endothermic reaction,

$\Delta H = +ve$  and at low temperature  $\Delta S = +ve$

Hence  $\Delta G = (+)\Delta H - T(+)\Delta S$

and if  $T\Delta S < \Delta H$  (at low temp)

$\Delta G = +ve$  (non spontaneous)

But at high temperature, reaction becomes

spontaneous i.e.  $\Delta G = -ve$ .

because at higher temperature  $T\Delta S > \Delta H$ .

2. (a) According to first law of thermodynamics energy can neither be created nor destroyed although it can be converted from one form to another.

**NOTE :** Carnot cycle is based upon this principle but during the conversion of heat into work some mechanical energy is always converted to other form of energy hence this data violates 1st law of thermodynamics.

3. (d)
- $\Delta H$
- negative shows that the reaction is spontaneous. Higher negative value for Zn shows that the reaction is more feasible.
- 
4. (b) The heat required to raise the temperature of body by 1K is called thermal capacity or heat capacity.

5. (c) For a cyclic process the net change in the internal energy is zero because the change in internal energy does not depend on the path.

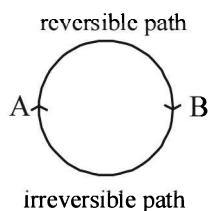

6. (c)
- $\text{CH}_2 = \text{CH}_2(\text{g}) + \text{H}_2(\text{g}) \rightarrow \text{CH}_3 - \text{CH}_3$
- 
- Enthalpy change = Bond energy of reactants - Bond energy of products.

$$\begin{aligned}\Delta H &= 1(\text{C}=\text{C}) + 4(\text{C}-\text{H}) + 1(\text{H}-\text{H}) - 1(\text{C}-\text{C}) - 6(\text{C}-\text{H}) \\ &= 1(\text{C}=\text{C}) + 1(\text{H}-\text{H}) - 1(\text{C}-\text{C}) - 2(\text{C}-\text{H}) \\ &= 615 + 435 - 347 - 2 \times 414 = 1050 - 1175 = -125 \text{ kJ}.\end{aligned}$$

7. (a) For spontaneous reaction,
- $dS > 0$
- and
- $dG$
- should be negative i.e.
- $< 0$
- .
- 
8. (c)
- $\Delta G^\circ = -RT \ln K_c$
- or
- $-\Delta G^\circ = RT \ln K_c$
- 
9. (b) Enthalpy change for a reaction does not depend upon the nature of intermediate reaction steps.

10. (c)
- $w = -P\Delta V = -10^{-5}(1 \times 10^{-2} - 1 \times 10^{-3}) = -900 \text{ J}$

11. (d) (i)
- $\text{C} + \text{O}_2 \rightleftharpoons \text{CO}_2, \Delta H = -393.5 \text{ kJmol}^{-1}$

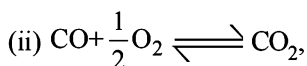

$$\Delta H = -283.0 \text{ kJmol}^{-1}$$

Operating (i) - (ii), we have

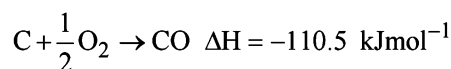

12. (d) Enthalpy of reaction (
- $\Delta H$
- ) =
- $E_{a(f)} - E_{a(b)}$
- 
- for an endothermic reaction
- $\Delta H = +ve$
- hence for
- $\Delta H$
- to be negative

$$E_{a(b)} < E_{a(f)}$$

13. (b)
- $\Delta H = \Delta U + \Delta nRT$
- for
- $\text{N}_2 + 3\text{H}_2 \rightarrow 2\text{NH}_3$

$$\Delta n_g = 2 - 4 = -2$$

$$\therefore \Delta H = \Delta U - 2RT \text{ or } \Delta U = \Delta H + 2RT \therefore \Delta U > \Delta H$$

14. (N)
- $\text{X}_2 + \text{Y}_2 \rightarrow 2\text{XY}, \Delta H = 2(-200)$
- .

Let  $x$  be the bond dissociation energy of  $\text{X}_2$ . Then

$$\Delta H = -400 = \xi_{x-x} + \xi_{y-y} - 2\xi_{x-y} = x + 0.5x - 2x = -0.5x$$

$$\text{or } x = \frac{400}{0.5} = 800 \text{ kJ mol}^{-1}$$

(In the question paper, this option was not mentioned. So the answer has been marked 'N')

15. (c)
- NOTE :**
- In a reversible process the work done is greater than in irreversible process. Hence the heat absorbed in reversible process would be greater than in the latter case. So

$$T_f(\text{rev.}) < T_f(\text{irr.})$$

16. (c) The standard enthalpy of formation of
- $\text{CH}_4$
- is given by the equation :

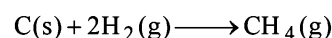

Hence, dissociation energy of hydrogen and enthalpy of sublimation of carbon is required.

17. (a)
- $\text{I}_2(\text{s}) + \text{Cl}_2(\text{g}) \rightarrow 2\text{ICl}(\text{g})$

$$\begin{aligned}\Delta A &= [\Delta I_2(\text{s}) \rightarrow I_2(\text{g}) + \Delta H_{\text{I-I}} + \Delta H_{\text{Cl-Cl}}] - 2[\Delta H_{\text{I-Cl}}] \\ &= 151.0 + 242.3 + 62.76 - 2 \times 211.3 = 33.46\end{aligned}$$

$$\Delta H_f^\circ(\text{ICl}) = \frac{33.46}{2} = 16.73 \text{ kJ/mol}$$

18. (d) For the reaction,
- $\text{C}(\text{s}) + \frac{1}{2}\text{O}_2(\text{g}) \rightarrow \text{CO}$

$$\Delta H = \Delta U + \Delta nRT \text{ or } \Delta H - \Delta U = \Delta nRT$$

$$\begin{aligned}\Delta n &= 1 - \frac{1}{2} = \frac{1}{2}; \Delta H - \Delta U = \frac{1}{2} \times 8.314 \times 298 \\ &= 1238.78 \text{ J mol}^{-1}\end{aligned}$$

19. (a)
- $\Delta G^\circ = \Delta H^\circ - T\Delta S^\circ$

For a spontaneous reaction  $\Delta G^\circ < 0$

$$\text{or } \Delta H^\circ - T\Delta S^\circ < 0 \Rightarrow T > \frac{\Delta H^\circ}{\Delta S^\circ}$$

$$\Rightarrow T > \frac{179.3 \times 10^3}{160.2} > 1117.9 \text{ K} \approx 1118 \text{ K}$$

20. (d) Given  $\Delta H = 41 \text{ kJ mol}^{-1} = 41000 \text{ J mol}^{-1}$   
 $T = 100^\circ\text{C} = 273 + 100 = 373 \text{ K}$ ,  $n = 1$   
 $\Delta U = \Delta H - \Delta nRT = 41000 - (2 \times 8.314 \times 373)$   
 $= 37898.88 \text{ J mol}^{-1} \approx 37.9 \text{ kJ mol}^{-1}$
21. (b) Spontaneity of reaction depends on tendency to acquire minimum energy state and maximum randomness. For a spontaneous process in an isolated system the change in entropy is positive.
22. (b) The energy involved in the conversion of

$\frac{1}{2} \text{Cl}_2(\text{g})$  to  $\text{Cl}^{-1}(\text{aq})$  is given by

$$\Delta H = \frac{1}{2} \Delta_{\text{diss}} H_{\text{Cl}_2}^{(-)} + \Delta_{\text{eg}} H_{\text{Cl}}^{(-)} + \Delta_{\text{hyd}} H_{\text{Cl}}^{(-)}$$

Substituting various values from given data, we get

$$\Delta H = \left( \frac{1}{2} \times 240 \right) + (-349) + (-381) \text{ kJ mol}^{-1}$$

$$= (120 - 349 - 381) \text{ kJ mol}^{-1} = -610 \text{ kJ mol}^{-1}$$

i.e., the correct answer is (b)

23. (c) For a reaction to be at equilibrium  $\Delta G = 0$ . Since  $\Delta G = \Delta H - T\Delta S$  so at equilibrium  $\Delta H - T\Delta S = 0$  or  $\Delta H = T\Delta S$

For the reaction

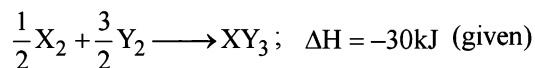

Calculating  $\Delta S$  for the above reaction, we get

$$\Delta S = 50 - \left[ \frac{1}{2} \times 60 + \frac{3}{2} \times 40 \right] \text{ JK}^{-1}$$

$$= 50 - (30 + 60) \text{ JK}^{-1} = -40 \text{ JK}^{-1}$$

At equilibrium,  $T\Delta S = \Delta H$  [ $\because \Delta G = 0$ ]

$$\therefore T \times (-40) = -30 \times 1000 \quad [\because 1 \text{ kJ} = 1000 \text{ J}]$$

$$\text{or } T = \frac{-30 \times 1000}{-40} \text{ or } 750 \text{ K}$$

24. (a) Given, for reaction  
 (i)  $\text{H}_2\text{O}(\ell) \longrightarrow \text{H}^+(\text{aq.}) + \text{OH}^-(\text{aq.}); \Delta H_r = 57.32 \text{ kJ}$

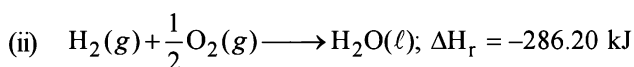

For reaction (i)

$$\Delta H_r = \Delta H^\circ_f(\text{H}^+, \text{aq.}) + \Delta H^\circ_f(\text{OH}^-, \text{aq.}) - \Delta H^\circ_f(\text{H}_2\text{O}, \ell)$$

$$57.32 = 0 + \Delta H^\circ_f(\text{OH}^-, \text{aq.}) - \Delta H^\circ_f(\text{H}_2\text{O}, \ell) \quad \dots \text{ (iii)}$$

For reaction (ii)

$$\Delta H_r = \Delta H^\circ_f(\text{H}_2\text{O}, \ell) - \Delta H^\circ_f(\text{H}_2, \text{g}) - \frac{1}{2} \Delta H^\circ_f(\text{O}_2, \text{g})$$

$$-286.20 = \Delta H^\circ_f(\text{H}_2\text{O}, \ell)$$

On replacing this value in equ. (iii) we have

$$57.32 = \Delta H^\circ_f(\text{OH}^-, \text{aq.}) - (-286.20)$$

$$\Delta H^\circ_f = -286.20 + 57.32 = -228.88 \text{ kJ}$$

25. (b)  $\text{N}_2 + 3\text{H}_2 \longrightarrow 2\text{NH}_3 \quad \Delta H = 2 \times -46.0 \text{ kJ mol}^{-1}$

Let  $x$  be the bond enthalpy of  $\text{N}-\text{H}$  bond then

[Note : Enthalpy of formation or bond formation enthalpy is given which is negative but the given reaction involves bond breaking hence values should be taken as positive.]

$$\Delta H = \Sigma \text{Bond energies of products}$$

$$- \Sigma \text{Bond energies of reactants}$$

$$2 \times -46 = 712 + 3 \times (436) - 6x; -92 = 2020 - 6x$$

$$6x = 2020 + 92 \Rightarrow 6x = 2112 \Rightarrow x = +352 \text{ kJ/mol}$$

26. (b) At equilibrium  $\Delta G = 0$

$$\text{Hence, } \Delta G = \Delta H - T_e \Delta S = 0$$

$$\therefore \Delta H = T_e \Delta S \quad \text{or} \quad T_e = \frac{\Delta H}{\Delta S}$$

For a spontaneous reaction

$\Delta G$  must be negative which is possible only if  $\Delta H < T\Delta S$

$$\text{or } T > \frac{\Delta H}{\Delta S}; T_e < T$$

27. (a) Entropy change for an isothermal reversible process is given by

$$\Delta S = nR \ln \frac{V_2}{V_1} = 2 \times 8.314 \times 2.303 \log \frac{100}{10}$$

$$= 38.3 \text{ J mol}^{-1} \text{ K}^{-1}$$

28. (c)  $\Delta G^\circ = \Delta H^\circ - T\Delta S^\circ$ ;  $-RT \ln K = \Delta H^\circ - T\Delta S^\circ$

$$\ln K = - \frac{\Delta H^\circ - T\Delta S^\circ}{RT}$$

30. (a)  $\text{C}_2\text{H}_5\text{OH}(\ell) + 3\text{O}_2(\text{g}) \rightarrow 2\text{CO}_2(\text{g}) + 3\text{H}_2\text{O}(\ell)$

Bomb calorimeter gives  $\Delta U$  of the reaction

$$\text{Given, } \Delta U = -1364.47 \text{ kJ mol}^{-1}$$

$$\Delta n_g = -1$$

$$\Delta H = \Delta U + \Delta n_g RT$$

$$= -1364.47 - \frac{1 \times 8.314 \times 298}{1000} = -1366.93 \text{ kJ mol}^{-1}$$

31. (b) Given

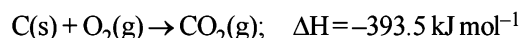

... (i)

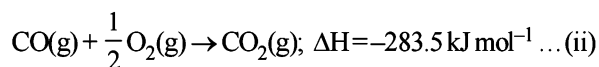

$\therefore$  Heat of formation of  $\text{CO} = \text{eqn(i)} - \text{eqn(ii)}$

$$= -393.5 - (-283.5) = -110 \text{ kJ}$$





# Equilibrium

## Section-A : JEE Advanced/ IIT-JEE

- A** 1.  $\text{SO}_4^{2-}$  2. amphoteric 3.  $K_p = K_c (RT)^{\Delta n}$  4. no change 5.  $\text{I}_2$
- B** 1. F 2. F 3. T 4. F
- C** 1. (b) 2. (a) 3. (d) 4. (b) 5. (d) 6. (a) 7. (b)  
 8. (b) 9. (c) 10. (a) 11. (a) 12. (c) 13. (d) 14. (d)  
 15. (a) 16. (d) 17. (c) 18. (d) 19. (a) 20. (d) 21. (a)  
 22. (d) 23. (a) 24. (d) 25. (d) 26. (b) 27. (c) 28. (a)  
 29. (b) 30. (a) 31. (b) 32. (d) 33. (a) 34. (a) 35. (d)  
 36. (d) 37. (b) 38. (c) 39. (b) 40. (a) 41. (d) 42. (d)
- D** 1. (a, b, c, d) 2. (c, d) 3. (a) 4. (c, d, e) 5. (d) 6. (b, c) 7. (a, c)  
 8. (c, d) 9. (a) 10. (b) 11. (a, b, d) 12. (b)
- E** 1. 5.3 g/l; 4.2 g/l; 2.  $1.5072 \times 10^{-2}$  mol, 4.09, 2 3.  $1.48 \times 10^{-5} \text{ l}^2 \text{ mol}^{-2}$ ,  $3.82 \times 10^{-3} \text{ litre mol}^{-1}$   
 4. 4.5686, 4.86 ml 5. (i)  $7 \times 10^{-2}\%$ , (ii) 4.1549, (iii)  $1.43 \times 10^{-10} \text{ mol/l}$   
 6.  $5.0 \times 10^{-13} \text{ M}$ , 99.83% 7. 33.3%, 0.41  
 8. (i)  $\text{N}_2 < \text{O}_2 < \text{F}_2 < \text{Cl}_2$ , (ii)  $\text{HClO} < \text{HClO}_2 < \text{HClO}_3 < \text{HClO}_4$ , (iii)  $\text{H}_2\text{O} < \text{CH}_3\text{OH} < \text{OH}^- < \text{CH}_3\text{O}^-$   
 (iv)  $\text{BaO} > \text{B}_2\text{O}_3 > \text{CO}_2 > \text{SO}_3 > \text{Cl}_2\text{O}_7$   
 9. 4.19 10. 1.886 11.  $8.7 \times 10^{-4} \text{ g/litre}$  12. 4.5686, 1  
 13. 1.6 moles, 0.4 moles 14. 0.266 atm, 64% 15.  $8.85 \times 10^{-3} \text{ M}$   
 16.  $p_{\text{SO}_2} = 0.0236 \text{ atm}$ ,  $p_{\text{O}_2} = 2.0118 \text{ atm}$ ,  $p_{\text{SO}_3} = 0.9764 \text{ atm}$  17. 46.29 mol ion/l,  $1.286 \times 10^{-15} \text{ mol ion/l}$   
 18.  $277.78 \text{ mol}^{-2} \text{ l}^2$ ,  $0.1144 \text{ atm}^{-2}$  19. 2.3724,  $2.78 \times 10^4 \text{ litres}$   
 20.  $3.794 \times 10^{-12} \text{ mol}^3 \text{ l}^{-3}$  21.  $1.828 \times 10^{-5}$  22. 743.3 mg  
 23. (i)  $0.05 \text{ atm}^{-2}$ ,  $187.85 \text{ mol}^{-2} \text{ l}^2$ , (ii) 12.438 atm 24. 78.36 ml 25. 0.983  
 26.  $\left[ \frac{2K_p}{P} \right]^{1/3}$  27.  $7.5 \times 10^{-18} \text{ M}$  28. 6.5 29. 11.5  
 30.  $1.71 \times 10^{-10}$  31. 2 32. 0.0538 M 33. 11.3010  
 34.  $8.1 \times 10^{-5} \text{ mol}^2 \text{ l}^{-2}$ ,  $4.90 \times 10^{-2} \text{ atm}^2$  35.  $1.203 \times 10^{-3} \text{ mol litre}^{-1}$   
 36. 4.865 37.  $1.75 \times 10^{-4}$ , 1, 4.75 38.  $x=0.63, y=0.53, z=0.98$
- G** 1. (a) 2. (b) 3. (b) 4. (c)
- H** 1. (d) 2. (c) 3. (d)
- I** 1. 9 2. 8 3. 3 4. 6 5. 7

## Section-B : JEE Main/ AIEEE

1. (a) 2. (a) 3. (a) 4. (a) 5. (c) 6. (b) 7. (d)  
 8. (b) 9. (b) 10. (d) 11. (d) 12. (d) 13. (c) 14. (b)  
 15. (d) 16. (b) 17. (c) 18. (a) 19. (d) 20. (a) 21. (a)  
 22. (a) 23. (c) 24. (c) 25. (b) 26. (d) 27. (d) 28. (c)  
 29. (a) 30. (c) 31. (c) 32. (c) 33. (a) 34. (a) 35. (c)  
 36. (b) 37. (b) 38. (a) 39. (d) 40. (c) 41. (d) 42. (b)  
 43. (d) 44. (b) 45. (a)

## Section-A

## JEE Advanced/ IIT-JEE

## A. Fill in the Blanks

- $\text{SO}_4^{2-}$ ; Conjugate base = Acid -  $\text{H}^+$   
 $\therefore$  Conjugate base of  $\text{HSO}_4^-$  is  $\text{SO}_4^{2-}$
- amphoteric**; because amphoteric substances show properties of both acids and basic.
- $k_p = k_c (RT)^{\Delta n}$ ;  
 Here  $\Delta n$  = No. of moles of gaseous products  
 - no. of moles of gaseous reactants  
 $R$  = gas constant, and  $T$  = absolute temperature.
- no change**; ( $K_p$  of an equilibrium reaction is independent of the pressure of the system.)
- $\text{I}_2$   $\therefore$  electron acceptors are Lewis acids.

## B. True/False

- False** :  $\text{AlCl}_3$  is a Lewis acid (although they do not have a proton, aprotic) because it accepts electrons (octet being incomplete).
- False** :  $K$  for  $A_2 + B_2 \rightleftharpoons 2AB$  is  $\frac{[AB]^2}{[A_2][B_2]}$   
 $K'$  for  $AB \rightleftharpoons \frac{1}{2}A_2 + \frac{1}{2}B_2$  is  $\frac{[A_2]^{1/2}[B_2]^{1/2}}{[AB]}$   
 or  $(K')^2 = \frac{[A_2][B_2]}{[AB]^2} = \frac{1}{K} \therefore K' = \sqrt{\frac{1}{K}}$
- True** : Lower the pressure, lower will be boiling point. More liquid will vapourise and temperature decreases.
- TIPS/Formulae** :  
 Dissolution of  $\text{NaOH}$  is exothermic.  
**False** : When a solute like  $\text{NaOH}$  is added to a solvent exothermic dissolution takes place. An increase in temperature always favour endothermic process. So solutes having exothermic dissolution shows a decrease in their solubility with temperature.

## C. MCQs with One Correct Answer

- (b) In molten state the cations and anions become free and flow of current is due to migration of these ions in opposite directions in the electric field.
- (a) **NOTE** : Acidic buffer is mixture of weak acid and its salt with common anion.  
 (a)  $\text{CH}_3\text{COOH} + \text{CH}_3\text{COONH}_4$  is acidic buffer.  
 (b)  $\text{NH}_4\text{Cl} + \text{NH}_4\text{OH}$  is basic buffer.  
 (c)  $\text{H}_2\text{SO}_4 + \text{Na}_2\text{SO}_4$  is not buffer because both the compounds are strong electrolytes.  
 (d)  $\text{NaCl} + \text{NaOH}$  is not buffer solution because both compounds are strong electrolytes.

## 3 (d) TIPS/Formulae :

- pH of acid cannot be more than 7.
- While calculating pH in such case, consider contribution  $[\text{H}^+]$  from water also.  
 Molar conc. of  $\text{HCl} = 10^{-8}$ . (given)  
 $\therefore$  pH = 8. But this cannot be possible as pH of an acidic solution can not be more than 7. So we have to consider  $[\text{H}^+]$  coming from  $\text{H}_2\text{O}$ .

$$\text{Total } [\text{H}^+] = [\text{H}^+]_{\text{HCl}} + [\text{H}^+]_{\text{H}_2\text{O}}$$

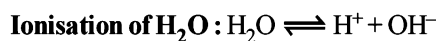

$$K_w = 10^{-14} = [\text{H}^+][\text{OH}^-]$$

Let  $x$  be the conc. of  $[\text{H}^+]$  from  $\text{H}_2\text{O}$

$$\text{or } [\text{H}^+] = x = [\text{OH}^-] \quad [\therefore [\text{H}^+] = [\text{OH}^-] \text{ in water}]$$

$$\therefore 10^{-14} = (x + 10^{-8})(x) \text{ or } x = 9.5 \times 10^{-8} \text{ M}$$

$$\left[ \text{For quadratic equation } x = \frac{-b \pm \sqrt{4ac}}{2a} \right]$$

$$\therefore \text{Total } [\text{H}^+] = 10^{-8} + 9.5 \times 10^{-8} = 10.5 \times 10^{-8} \text{ or pH} \\ = -\log(10.5 \times 10^{-8}) = \mathbf{6.98}$$

It is between 6 and 7.

## 4 (b) TIPS/Formulae :

- According to Le-Chateliers principle, exothermic, reactions are favoured at low temperature.
- According to Le-Chateliers principle, the reaction in which  $n < 0$ , are favoured at high pressure.

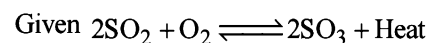

$\therefore$  It is exothermic reaction

$\therefore$  Yield of  $\text{SO}_3$  is maximum at low temperature

$$n = 2 - 3 = -1 \text{ or } n < 0$$

$\therefore$  Yield of  $\text{SO}_3$  is maximum at high pressure.

- (d) Only temperature affects the equilibrium constant. Since here  $\Delta H = 2 - 2 = 0$ , so there is no change in  $K_p$  when total pressure changes.

## 6 (a) TIPS/Formulae :

- Lower the oxidation state of central atom, weaker will be oxy acid.
- Weaker the acid, stronger will be its conjugate base. Oxidation state of Cl in  $\text{HClO}$  is +1, in  $\text{HClO}_2$  is +3, in  $\text{HClO}_3$  is +5, and in  $\text{HClO}_4$  is +7  
 $\therefore$   $\text{HClO}$  is the weakest acid and so its conjugate base  $\text{ClO}^-$  is the strongest Bronsted base.

- (b) For pure water,  $[\text{H}_3\text{O}^+] = [\text{OH}^-]$   
 $\Rightarrow K_w = 10^{-6} \times 10^{-6} = 10^{-12}$

## 8 (b) TIPS/Formulae :

For precipitation to occur ionic product > solubility products

$$\text{Given, } K_{sp} \text{CaF}_2 = 1.7 \times 10^{-10}$$

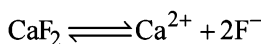

$$\text{Ionic product of CaF}_2 = [\text{Ca}^{2+}] [\text{F}^-]^2$$

Calculate I.P. in each case

$$(a) \text{ I.P. of CaF}_2 = (10^{-4}) \times (10^{-4})^2 = 10^{-12}$$

$$(b) \text{ I.P. of CaF}_2 = (10^{-2}) \times (10^{-3})^2 = 10^{-8}$$

$$(c) \text{ I.P. of CaF}_2 = (10^{-5}) \times (10^{-3})^2 = 10^{-11}$$

$$(d) \text{ I.P. of CaF}_2 = (10^{-3}) \times (10^{-5})^2 = 10^{-13}$$

$\therefore$  I.P. > solubility in choice (b) only.

$\therefore$  ppt of  $\text{CaF}_2$  is obtained in case of choice (b) only.

9. (c) Vapours and liquid are at the same temperature.

10. (a) Statement (a) is correct and the rest statements are wrong.  $K_p$  depends only on temperature hence at constant temp.  $K_p$  will not change.

11. (a) For a basic buffer,  $\text{pH} = 14 - \text{p}K_b - \log \frac{[\text{salt}]}{[\text{base}]}$

$$\text{pH} = 14 - \text{p}K_b - \log \frac{[\text{salt}]}{[\text{base}]} = 14 - (-\log 10^{-10}) - \log 1$$

$$\Rightarrow \text{pH} = 4$$

12. (c) **TIPS/Formulae :**

The equilibrium constant for the neutralization of a weak acid with a strong base is given by

$$K = K_a / K_w = \frac{1.0 \times 10^{-4}}{1.0 \times 10^{-14}} = 1.0 \times 10^{10}$$

13. (d) As all the reactants and products are present in aqueous form in (d) so it is a reversible reaction. In others either solid or gas is generated which is insoluble or volatile and hence makes the reaction unidirectional.

14. (d) **TIPS/Formulae :**

The pH of the solution at the equivalence point will be greater than 7 due to salt hydrolysis. So an indicator giving colour in basic medium will be suitable.

Phenolphthalein is a good indicator if the base is strong because strong base immediately changes the pH at end point.

15. (a)  $\text{Base} + \text{H}^+ \rightarrow (\text{conjugate acid})$

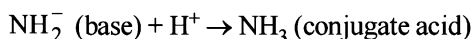

16. (d) **NOTE :** Electron acceptors or elements having incomplete octet are Lewis acids.

(i)  $\text{BF}_3$  (B has 6  $e^-$  in valance shell),  $\text{AlCl}_3$  (Al has 6 electrons in valance shell),  $\text{BeCl}_2$  (Be has 4  $e^-$  in valance shell) are electron defecient compounds and hence Lewis acids.

(ii)  $\text{SnCl}_4$  has complete octet so it is Lewis base.

17. (c)  $\text{CaO}$ ,  $\text{CaCO}_3$  and  $\text{Ca(OH)}_2$  dissolve in  $\text{CH}_3\text{COOH}$  due to formation of  $(\text{CH}_3\text{COO})_2\text{Ca}$ . But  $\text{CaC}_2\text{O}_4$  does not dissolve as  $\text{CH}_3\text{COO}^-$  is a stronger conjugate base than  $\text{C}_2\text{O}_4^{2-}$ .

18. (d) (a) is a neutral solution due to both cationic and anionic hydrolysis ( $K_a = K_b = 1.8 \times 10^{-5}$ ); (b) is acidic solution due to cationic hydrolysis; (c) is acidic solution due to cationic hydrolysis; (d) is basic solution due to anionic hydrolysis.

Alternate solution. Step-1.

19. (a) For a precipitation to occur

Solubility product < Ionic product

$$\text{Given } K_{sp} = 1.8 \times 10^{-10}$$

Calculating ionic products in each

$$\text{Ionic product} = [\text{Ag}^+] [\text{Cl}^-] = \frac{10^{-4}}{2} \times \frac{10^{-4}}{2}$$

$$= 2.5 \times 10^{-9}$$

which is greater than  $K_{sp}$  ( $1.8 \times 10^{-10}$ ).

$$\left( \begin{array}{l} \therefore \text{equal volumes are mixed,} \\ \text{so } [\text{Ag}^+] = \frac{10^{-4}}{2} \text{ and } [\text{Cl}^-] = \frac{10^{-4}}{2} \end{array} \right)$$

Step-2

20. (d) **TIPS/Formulae :**

In acidic medium weak acids are unionized due to common ion effect and they are completely ionised in alkaline medium.

Aspirin (or acetyl salicylic acid) is unionised in stomach (where pH is 2-3) and is completely ionised in small intestine (when pH is 8).

21. (a) **TIPS/Formulae :**

(i) Higher the electronegativity of central atom higher will be the acidic strength.

(ii) In case of same atom higher the value of oxidation state of the metal, higher will be its acidic strength.

The electronegativity of  $\text{Cl} > \text{S}$ .

$$\text{Oxidation no. of Cl in } \text{ClO}_3(\text{OH}) = +7$$

$$\text{Oxidation no. of Cl in } \text{ClO}_2(\text{OH}) = +5$$

$$\text{Oxidation no. of S in } \text{SO}(\text{OH})_2 = +4$$

$$\text{Oxidation no. of S in } \text{SO}_2(\text{OH})_2 = +6$$

$\therefore$   $\text{ClO}_3(\text{OH})$  is the strongest acid.

22. (d) **NOTE :** In case of alkaline earth hydroxides solubility increases on moving down the group.

$\text{Be(OH)}_2$  has lowest solubility and hence lowest solubility product. [Be at top of the group]

23. (a) Due to absence of hydrolysis of  $\text{FeCl}_3$  backward reaction will not take place.

24. (d) Since HCl is stronger than  $\text{CH}_3\text{COOH}$  hence acts as acid. On the other hand  $\text{Cl}^-$  is a stronger base than  $\text{CH}_3\text{COOH}_2^+$  and is the conjugate base of HCl.

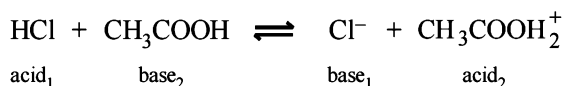

25. (d) (a) It is not correct answer because 100 ml M/10 HCl will completely neutralise 100 ml M/10 NaOH and the solution will be neutral.

(b) After neutralisation resultant solution will be acidic due to presence of excess of HCl.

(c) After neutralisation resultant solution will be basic due to presence of excess of NaOH.

(d) M. eq. of HCl = 75 N/5 = 15 Meq

$$\text{M. eq. of NaOH} = 25 \times \frac{1}{5} = 5 \text{ Meq}$$

$$\therefore \text{M. eq. of HCl left} = 10 \therefore [\text{HCl}] = \frac{10}{100} = \text{M}/10$$

$$\therefore \text{pH} = -\log [\text{H}^+] = -\log \left[ \frac{1}{10} \right] = 1$$

26. (b) TIPS/Formulae :

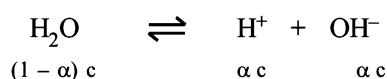

$$\alpha = 1.9 \times 10^{-7}; \text{ Density of water} = \frac{1.0 \text{ gm}}{\text{cm}^3}$$

$$\therefore c = \frac{1}{18} \times 1000 = 55.56 \text{ moles/l}$$

$$\therefore [\text{H}^+] = 55.56 \times 1.9 \times 10^{-9} = 1.055 \times 10^{-7}$$

$$[\therefore 1.9 \times 10^{-9} \% = 1.9 \times 10^{-9}]$$

$$\therefore K_w = [\text{H}^+][\text{OH}^-] = (1.055 \times 10^{-7})^2 = 1.0 \times 10^{-14}$$

27. (c) Salts of weak base and strong acid get hydrolysed in aqueous solution forming an acidic solution.

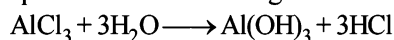

(weak)                                    (strong)                            (acidic)

28. (a) Among oxyacids of the same type formed by different elements, acidic nature increases with increasing electronegativity. In general, the strength of oxyacids decreases as we go down the family in the periodic table.



[In halogen groups Cl is above Br and I]

29. (b) The characteristics of the given solutions are:

NaCl – neutral solution

$\text{NH}_4\text{Cl}$  – slightly acidic due to the following reaction

$$\text{NH}_4^+ + \text{H}_2\text{O} \rightleftharpoons \text{NH}_4\text{OH} + \text{H}^+$$

NaCN – slightly alkaline due to the following reaction

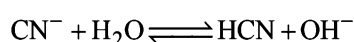

HCl – highly acidic

The pH of the solution will follow the order highly acidic < slightly acidic < neutral < slightly alkaline i.e.  $\text{HCl} < \text{NH}_4\text{Cl} < \text{NaCl} < \text{NaCN}$

30. (a) The given reaction will be exothermic in nature due to the formation of three X - Y bonds from the gaseous atoms. The reaction is also accompanied with the decrease in the gaseous species (i.e.  $\Delta n$  is negative). Hence, the reaction will be affected by both temperature and pressure. The use of catalyst does not affect the equilibrium concentrations of the species in the chemical reaction.

31. (b)  $K_b = K_c \cdot (RT)^{\Delta n}$

$$\Delta n = 2 - 4 = -2 \quad K_c = \frac{K_p}{(RT)^{\Delta n}} = \frac{1.44 \times 10^{-5}}{(0.082 \times 773)^{-2}}$$

(R in L.atm.K<sup>-1</sup> mole<sup>-1</sup>).

32. (d) At initial stage of reaction, concentration of each product will increase and hence Q will increase.

33. (a) TIPS/Formulae :

For oxyacids containing similar central atom, the acid strength increases with the increase in the number of oxygen atom attached to the central atom and not attached to any other atom.

TIPS/Formulae :

Higher the oxidation number of the central atom, higher is the acidity of the species. Thus acidity follows the order

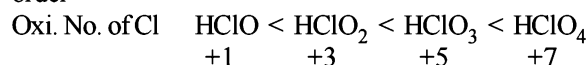

34. (a)  $A_p B_q(s) \rightleftharpoons pA^{+q} + qB^{-p}$

$$L_S = (pS)^p \cdot (qS)^q = p^p \cdot q^q \cdot S^{(p+q)}$$

35. (d) At constant temperature  $K_p$  pressure constant.

With change of pressure,  $x$  will change in such a way that  $K_p$  remains a constant.

36. (d) TIPS/Formulae :

At constant temperature  $K_p$  or  $K_c$  remains constant.

For the equilibria :

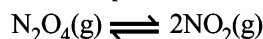

NOTE :  $K_p = K_c$  because here  $\Delta n = 1$

[ $K_p = K_c \times (RT)^{\Delta n}$ ] Since temperature is constant so  $K_c$  or  $K_p$  will remain constant. Further since volume is halved, the pressure will be doubled so  $\alpha$  will decrease so as to maintain the constancy of  $K_c$  or  $K_p$ .

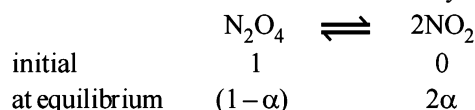

$$\therefore \text{Total mole} = 1 - \alpha + 2\alpha = 1 + \alpha$$

Let total pressure = P

$$\therefore p_{\text{N}_2\text{O}_4} = \frac{1-\alpha}{1+\alpha} \cdot p; p_{\text{NO}_2} = \frac{2\alpha}{1+\alpha} \cdot p$$

$$K_p = \frac{(p\text{NO}_2)^2}{p\text{N}_2\text{O}_4} = \frac{4\alpha^2 \times p}{(1-\alpha)(1+\alpha)} = \frac{4\alpha^2 p}{1-\alpha^2}$$

$$\text{Since } K_p = \text{constant, so } \alpha \propto \frac{1}{\sqrt{p}}$$

So when volume is halved, pressure gets doubled and thus  $\alpha$  will decrease.

$$37. \text{ (b) } h = \sqrt{\frac{K_w}{K_a \times c}} = \sqrt{\frac{10^{-14}}{10^{-5} \times 0.1}} = 10^{-4};$$

Hence, % hydrolysis =  $10^{-4} \times 100 = 0.01$

38. (c) **NOTE :** For isotonic solutions, osmotic pressure is same.

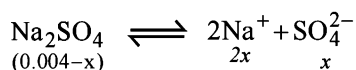

Since both solutions are isotonic, therefore,  $0.004 + 2x = 0.01$ ;  $x = 3 \times 10^{-3}$

$$\therefore \% \text{ Dissociation} = \frac{3 \times 10^{-3}}{0.004} \times 100 = 75\%$$

**Alternate eqn.** Total no. of moles =  $0.004 \times x + 2x + x$

39. (b) **NOTE:**

For basic buffer pH is more than 7.

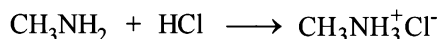

Initial moles	0.1	0.08	0
Moles after mixing	0.02	0	0.08

As it is a basic buffer solution.

$$p\text{OH} = pK_b + \log \frac{0.08}{0.02} = -\log 5 \times 10^{-4} + \log 4$$

$$= 3.30 + 0.602 = 3.902$$

$$p\text{H} = 14 - 3.902 = 10.09; [\text{H}^+] = 7.99 \times 10^{-11} \approx 8 \times 10^{-11} \text{ M}$$

40. (a) In a reversible reaction, catalyst speeds up both the forward and backward reactions to the same extent, so (c) is wrong. At equilibrium,

$$\Delta G = G_{\text{products}} - G_{\text{reactants}} = 0$$

$$\Rightarrow 2G_{\text{NH}_3} - (G_{\text{N}_2} + 3G_{\text{H}_2}) = 0$$

$$\text{or } 2G_{\text{NH}_3} = G_{\text{N}_2} + 3G_{\text{H}_2}$$

41. (d) Let the weak monoacidic base be BOH, then the reaction that occurs during titration is

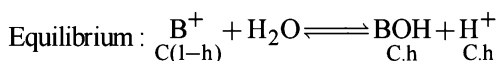
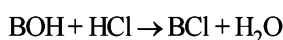

Using the normality equation,  $N_1 V_1 = N_2 V_2$   
(acid) (base)

Substituting various given values, we get

$$\frac{2}{15} \times V_1 = 2.5 \times \frac{2}{5}$$

$$\text{or } V_1 = 2.5 \times \frac{2}{5} \times \frac{15}{2} = 2.5 \times 3 = 7.5 \text{ ml}$$

Then the concentration of BCl in resulting solution is given by

$$[\text{BCl}] = \frac{\frac{2}{15} \times 2.5}{10} = \frac{2}{10} \text{ or } 0.1 \text{ M}$$

$$\text{Since } K_h = \frac{K_w}{K_b} \quad \therefore K_h = \frac{1 \times 10^{-14}}{1 \times 10^{-12}} = 10^{-2}$$

$$\text{Thus } K_h = \frac{0.1h^2}{(1-h)} \quad \text{or} \quad 10^{-2} = \frac{0.1h^2}{(1-h)}$$

$$\text{or } 10^{-2} - 10^{-2}h = 0.1h^2 \quad \text{or} \quad 0.1h^2 + 10^{-2}h - 10^{-2} = 0$$

(Solving this quadratic equation for h, we get)

$$h = \frac{-10^{-2} \pm \sqrt{(10^{-2})^2 + 4 \times 10^{-1} \times 10^{-2}}}{2 \times 0.1}$$

$$\left[ x = \frac{-b \pm \sqrt{b^2 - 4ac}}{2a} \right] = \frac{-10^{-2} \pm \sqrt{10^{-4} + 4 \times 10^{-3}}}{2 \times 0.1}$$

$$= \frac{-0.01 \pm \sqrt{0.0001 + 0.004}}{0.2} = \frac{-0.01 \pm \sqrt{0.0041}}{0.2}$$

$$= \frac{-0.01 \pm 0.64}{0.2} = \frac{0.54}{0.2} \quad [\text{Neglecting the negative term}]$$

$$= 0.27$$

$$\therefore [\text{H}^+] = C \cdot h = 0.1 \times 0.27 = 2.7 \times 10^{-2} \text{ M}$$

Thus the correct answer is [d].

42. (d)  $\text{MX} \longrightarrow \text{M}^+ + \text{X}^-$  (Where s is the solubility)

$$\text{Then } K_{\text{sp}} = s^2 \quad \text{or} \quad s = \sqrt{K_{\text{sp}}}$$

$$\text{Similarly for } \text{MX}_2 \longrightarrow \text{M}^{2+} + 2\text{X}^-$$

$$K_{\text{sp}} = s \times (2s)^2 = 4s^3 \quad \text{or} \quad s = \left[ \frac{K_{\text{sp}}}{4} \right]^{\frac{1}{3}}$$

$$\text{and for } \text{M}_3\text{X} \longrightarrow 3\text{M}^+ + \text{X}^{3-}$$

$$K_{\text{sp}} = (3s)^3 \times s = 27s^4 \quad \text{or} \quad s = \left[ \frac{K_{\text{sp}}}{27} \right]^{\frac{1}{4}}$$

From the given values of  $K_{\text{sp}}$  for MX,  $\text{MX}_2$  and  $\text{M}_3\text{X}$ , we can find the solubilities of those salts at temperature, T.

$$\text{Solubility of MX} = \sqrt{4 \times 10^{-8}} = 2 \times 10^{-4}$$

$$\text{Solubility of } MX_2 = \left[ \frac{3.2 \times 10^{-14}}{4} \right]^{\frac{1}{3}} \text{ or } \left[ \frac{32}{4} \times 10^{-15} \right]^{\frac{1}{3}}$$

$$= \left[ 8 \times 10^{-15} \right]^{\frac{1}{3}} \text{ or } 2 \times 10^{-5}$$

$$\text{Solubility of } M_3X = \left[ \frac{2.7 \times 10^{-15}}{27} \right]^{\frac{1}{4}}$$

$$= \left[ 10^{-16} \right]^{\frac{1}{4}} \text{ or } 10^{-4}$$

Thus the solubilities are in the order  $MX > M_3X > MX_2$   
i.e. the correct answer is (d).

#### D. MCQs with One or More Than One Correct

1. (a, b, c, d) The reaction is exothermic, hence increasing temperature will favour backward reaction (i.e. conc. of  $C_2H_4$  increases) removing  $H_2$  and adding  $C_2H_6$  favours backward reaction.

2. (c, d)  $2NaNO_3 \rightleftharpoons 2NaNO_2 + O_2$   
According to Le-chatelier principle an increase in pressure always favours the reaction, where volume or moles decrease (i.e. reverse direction). As heat is added, i.e. reaction is endothermic and is supported in forward direction with increase in temperature.

3. (a) At constant volume, concentrations do not change.

4. (c, d, e) Introduction of an inert gas at constant pressure causes the equilibrium to shift in a direction in which number of moles increases. The forward reaction is further accelerated by increase in the quantity of substrate, i.e.,  $PCl_5$  and by the increase of space, i.e., volume of container.

5. (d)  $CO_{(g)} + H_2O_{(g)} \rightleftharpoons CO_{2(g)} + H_{2(g)}$

$$K_C = \frac{[CO_2][H_2]}{[CO][H_2O]}$$

A catalyst simply helps in attaining the equilibrium earlier.

Addition of inert gas has no effect on a reaction because in it  $\Delta n = 0$ .

This equilibrium is not based upon volume because in it  $\Delta n = 0$ .

On increasing the amount of CO,  $K_C$  will decrease but it is constant at constant temperature, so for maintaining the constant value of  $K_C$ , the amount of  $CO_2$  increases.

6. (b, c)  $pH$  of  $1 \times 10^{-8}$  M is below 7 because it is an acid.

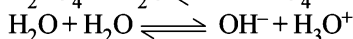
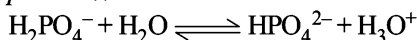

$K$  (Auto protolysis constant of water i.e. ionic product of water) increases with temperature. For half neutralisation of a weak acid by a weak base,

$$pH = pK_a + \log \frac{[\text{Salt}]}{[\text{Acid}]}$$

$$[\text{Salt}] = [\text{Acid}], \therefore pH = pK_a$$

7. (a, c) A buffer solution is prepared by mixing a weak acid/base with salt of its conjugate base/acid.

8. (c, d) Any solution of a weak acid and its salt with strong base acts as an acidic buffer solution.

If volume of  $HNO_3$  solution added is less as compared to that of  $CH_3COONa$  solution, it results in the formation of an acidic buffer solution.

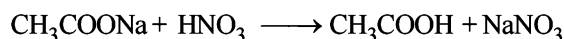

Excess limiting reagent

$MV$	$MV'$	-	-
$M(V-V')$	0	$MV'$	$MV'$ ( $V' < V$ )

9. (a) As ester hydrolysis is first order with respect  $[H^+]$ .

$$R_{HA} = K[H^+]_{HA} [\text{ester}]$$

$$R_{HX} = K[H^+]_{HX} [\text{ester}]$$

$$\therefore \frac{R_{HA}}{R_{HX}} = \frac{[H^+]_{HA}}{[H^+]_{HX}}; \frac{1}{100} = [H^+]_{HA} = 0.01$$

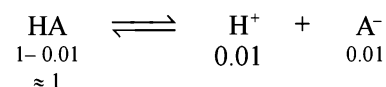

$$K_a = \frac{0.01 \times 0.01}{1} = 10^{-4}$$

10. (b)  $Ag_2CrO_4 \rightleftharpoons 2Ag^+ + CrO_4^{2-}$

$$K_{sp} = 1.1 \times 10^{-12} = [Ag^+]^2 [CrO_4^{2-}]$$

$$1.1 \times 10^{-12} = [0.1]^2 [s]; s = 1.1 \times 10^{-10}$$

11. (a, b, d)

$$(A) \Delta H = C_{p(\text{rxn})} \Delta T$$

Hence enthalpy depends on temperature.

$$(B) CaCO_{3(s)} \rightleftharpoons CaO_{(s)} + CO_{2(g)} \quad K_p = P_{CO_2}$$

(C)  $K_{eq}$  depends only on temperature and not on Pressure.

(D) Enthalpy of reaction is independent of the catalyst. Catalyst generally changes activation energy.

12. (b) Initially on increasing temperature rate of reaction will increase, so % yield will also increase with time. But at equilibrium % yield at high temperature ( $T_2$ ) would be less than at  $T_1$  as reaction is exothermic so the graph is

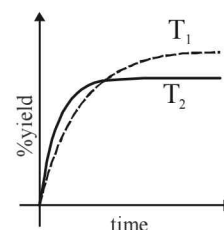

### E. Subjective Problems

1. Phenolphthalein indicates half neutralization.



Methyl orange indicates complete neutralisation

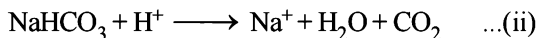

$\therefore$  Volume of 0.1 M  $\text{H}_2\text{SO}_4$  required for complete neutralisation =  $2 \times 2.5 = 5.0$  ml

$$0.1 \text{ M } \text{H}_2\text{SO}_4 \equiv 0.2 \text{ NH}_2\text{SO}_4$$

[For  $\text{H}_2\text{SO}_4$  molarity =  $2 \times$  normality]

( $\therefore$  Mol. wt. of  $\text{H}_2\text{SO}_4 = 98$ , and eq. wt. of  $\text{H}_2\text{SO}_4 = 49$ )

$$\therefore 0.2 \text{ M } \text{H}_2\text{SO}_4 \equiv 0.4 \text{ NH}_2\text{SO}_4$$

$N_1 =$  normality of  $\text{Na}_2\text{CO}_3$ ,  $V_1 =$  volume of  $\text{Na}_2\text{CO}_3 = 10$  ml,

$N_2 =$  normality of  $\text{H}_2\text{SO}_4 = 0.2$ ,  $V_2 =$  volume of  $\text{H}_2\text{SO}_4 = 5.0$  ml

$$\therefore N_1 V_1 = N_2 V_2 \Rightarrow N_1 \times 10 = 0.2 \times 5$$

$$\therefore N_1 = \frac{0.2 \times 5}{10} = 0.1 \text{ N}$$

$$\therefore \text{Eq. wt. of } \text{Na}_2\text{CO}_3 = \frac{1}{2} \times \text{molecular weight} = \frac{106}{2} = 53$$

Strength of  $\text{Na}_2\text{CO}_3 = 53 \times 0.1 = 5.3 \text{ g/l}$

[ $\therefore$  strength = normality  $\times$  Eq. wt]

For neutralization with methyl orange, volume of 0.2 M  $\text{H}_2\text{SO}_4$  used = 2.5 ml = 2.5 ml of 0.4 N  $\text{H}_2\text{SO}_4$

$$= 5 \text{ ml of } 0.2 \text{ N } \text{H}_2\text{SO}_4 \quad [\therefore N_1 V_1 = N_2 V_2]$$

From 5 ml of 0.2 N  $\text{H}_2\text{SO}_4$ , 2.5 ml is used for neutralising  $\text{NaHCO}_3$  formed during first half neutralization  $\text{Na}_2\text{CO}_3$

$\therefore$  Volume of 0.2 N  $\text{H}_2\text{SO}_4$  used for neutralisation of  $\text{NaHCO}_3$  present in original solution =  $5.0 - 2.5 = 2.5$  ml

$$\therefore N_1 V_1 = N_2 V_2$$

where  $N_1 =$  Normality of  $\text{NaHCO}_3$ ,

$N_2 =$  Normality of  $\text{H}_2\text{SO}_4 = 0.2$ ,

$V_1 =$  Volume of  $\text{NaHCO}_3 = 10$  ml,  $V_2 =$  Volume of  $\text{H}_2\text{SO}_4 = 2.5$  ml

$$N_1 V_1 = N_2 V_2 \Rightarrow N_1 \times 10 = 0.2 \times 2.5$$

$$N_1 = \frac{0.2 \times 2.5}{10} = 0.05 \text{ N}$$

Eq. wt. of  $\text{NaHCO}_3 = 84$

$\therefore$  Strength of  $\text{NaHCO}_3 = 84 \times 0.05 = 4.2 \text{ g/l}$

2. Suppose the number of moles of sodium propionate =  $x$

$$\text{Then } pH = pK_a + \log \frac{[\text{Salt}]}{[\text{Acid}]}$$

$$4.75 = -\log(1.34 \times 10^{-5}) + \log \left( \frac{x}{0.02} \right)$$

$$\text{or } 4.75 = 5 - 0.1271 + \log \frac{x}{0.02}$$

$$\text{or } 4.75 = 4.8729 + \log \frac{x}{0.02}$$

$$\log \frac{x}{0.02} = -0.1229$$

$$\text{or } \frac{x}{0.02} = \text{Antilog}[-0.1229] \quad \text{or } \frac{x}{0.02} = 0.7536$$

$$x = 0.7536 \times 0.02 = 1.5072 \times 10^{-2} \text{ mol}$$



0.01 mole                      0.01 mole

When 0.01 mole of HCl is added, there is (0.01 + 0.02) M of propionic acid and (0.015 - 0.010) M of propionate. Therefore

$$pH = -\log(1.34 \times 10^{-5}) + \log \frac{0.005}{0.03} = 4.09$$

The  $pH$  of a 0.010 molar HCl solution =  $-\log 10^{-2} = 2$

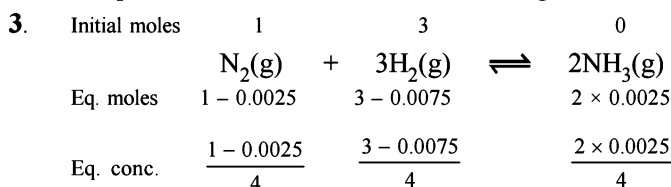

$$\text{Now we know that } K_c = \frac{[\text{NH}_3]^2}{[\text{N}_2][\text{H}_2]^3}$$

Since 0.0025 and 0.0075 are very small,  $1 - 0.0025$  and  $3 - 0.0075$  may be taken as 1 and 3 respectively.

Substitute the various values

$$K_c = \frac{\left( \frac{2 \times 0.0025}{4} \right)^2}{\left[ \frac{1}{4} \right] \left[ \frac{3}{4} \right]^3} = \frac{0.0025 \times 0.0025}{4} \times \frac{4 \times 4 \times 4 \times 4}{3 \times 3 \times 3}$$

$$= 1.48 \times 10^{-5} \text{ litre}^2 \text{ mol}^{-2}$$

For the equilibrium,

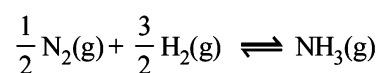

$$K_c' = \frac{[\text{NH}_3]}{[\text{N}_2]^{1/2} [\text{H}_2]^{3/2}} = \sqrt{K_c}$$

$$= \sqrt{(1.48 \times 10^{-5} \text{ litre}^2 \text{ mol}^{-2})}$$

$$= 3.82 \times 10^{-3} \text{ litre mol}^{-1}$$

4. TIPS/Formulae :

(i) Find the moles of each species after reaction.

$$(ii) \quad pH = -\log K_a + \log \left[ \frac{\text{salt}}{\text{Acid}} \right]$$

Given, NaOH 0.2 M, 20 ml;  $\text{CH}_3\text{COOH}$  0.2 M, 50 ml

$$K_a = 1.8 \times 10^{-5}$$

$V$  of 0.2 M NaOH required to make  $pH = 4.74 = ?$

From the chemical reaction

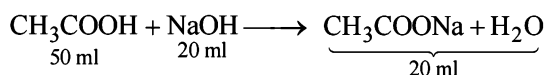

It is evident that 70 ml of the product will contain

- (i) 30 ml of 0.2 M unused  $\text{CH}_3\text{COOH}$   
[unused  $\text{CH}_3\text{COOH} = 50 - 20 = 30$  ml]  
(ii) 20 ml of  $\text{CH}_3\text{COONa}$ .  
 $\therefore$  No. of moles of  $\text{CH}_3\text{COOH}$  in solution

$$= \frac{0.2}{1000} \times 30 = 0.006 \text{ mole}$$

Similarly, No. of moles of  $\text{CH}_3\text{COONa}$  solution

$$= \frac{0.2}{1000} \times 20 = 0.004 \text{ moles}$$

$$pH = -\log K_a + \log \frac{[\text{Salt}]}{[\text{Acid}]}$$

Substituting the values of the various values

$$pH = -\log 1.8 \times 10^{-5} + \log \frac{0.004}{0.006}$$

$$= 4.7447 - 0.1761 = \mathbf{4.5686}$$

Calculation of the additional volume of 0.2 M NaOH required to make pH of solution 4.74.

$$pH = -\log K_a + \log \frac{[\text{Salt}]}{[\text{Acid}]}$$

$$\text{or } 4.74 = -\log 1.8 \times 10^{-5} + \log \frac{[\text{Salt}]}{[\text{Acid}]}$$

$$\text{or } 4.74 = 4.7447 + \log \frac{[\text{Salt}]}{[\text{Acid}]}$$

$$\therefore \log \frac{[\text{Salt}]}{[\text{Acid}]} = 0.0047 \text{ or } \frac{[\text{Salt}]}{[\text{Acid}]} = \frac{1}{1.011}$$

**NOTE THIS STEP:** Let  $x$  ml. be the volume of additional 0.2 M NaOH added to make the pH of the solution 4.74. This will further neutralise  $x$  ml. of 0.2 M  $\text{CH}_3\text{COOH}$  and produce  $x$  ml. of 0.2 M sodium acetate. The resulting solution  $(70 + x)$  will now contain

- (i)  $(30 - x)$  ml of 0.2 M acetic acid.  
(ii)  $(20 + x)$  ml of 0.2 M sodium acetate.

Number of moles of acetic acid in  $(70 + x)$  ml. solution

$$= \frac{0.2}{1000} \times (30 - x) = 2 \times 10^{-4} (30 - x)$$

Number of moles of  $\text{CH}_3\text{COONa}$  in  $(70 + x)$  ml. solution

$$= \frac{0.2}{1000} \times (20 + x) = 2 \times 10^{-4} (20 + x)$$

$$\text{Therefore, } \frac{[\text{Salt}]}{[\text{Acid}]} = \frac{2 \times 10^{-4} (20 + x)}{2 \times 10^{-4} (30 - x)} = \frac{20 + x}{30 - x}$$

$$\frac{1}{1.011} = \frac{20 + x}{30 - x} \text{ or } 20.22 + 1.011x = 30 - x$$

$$\text{or } 1.001x + x = 30 - 20.22; \quad 2.011x = 9.78 \text{ or } x = 4.86$$

Therefore, the additional volume of 0.2 M NaOH required to make the pH of the solution 4.74 is **4.86 ml**.

5. (i) From the dissociation of weak acid HA,

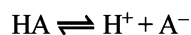

It  $\alpha$  is the degree of ionization of the acid HA,

then  $[\text{H}^+] = 0.1 \alpha$  [ $\because$  the acid is decimolar]

$$[\text{A}^-] = 0.1 \alpha; [\text{HA}] = 0.1(1 - \alpha)$$

Therefore,

$$K_a = \frac{[\text{H}^+][\text{A}^-]}{[\text{HA}]} = \frac{0.1\alpha \times 0.1\alpha}{0.1(1 - \alpha)}$$

$$= \frac{0.1\alpha \times 0.1\alpha}{0.1} \quad (\text{since acid is weak, } 1 - \alpha = 1)$$

$$K_a = 0.1 \alpha^2 \text{ or } 4.9 \times 10^{-8} = 0.1 \alpha^2$$

$$\text{or } \alpha^2 = \frac{4.9 \times 10^{-8}}{0.1} \text{ or } \alpha = 7 \times 10^{-4}$$

$$\therefore \text{Percentage ionization} = 100 \times 7 \times 10^{-4} = 7 \times 10^{-2}\%$$

- (ii) Calculation of pH

$$[\text{H}^+] = 0.1\alpha = 0.1 \times 7 \times 10^{-4} \text{ mole/litre } [\because \lambda = 7 \times 10^{-4}]$$

$$= 7 \times 10^{-5} \text{ mole/litre}$$

$$\text{Now since } pH = -\log [\text{H}^+] = -\log [7 \times 10^{-5}]$$

$$= 5 - \log 7 = 5 - 0.8451 = \mathbf{4.1549}$$

- (iii) Concentration of  $\text{OH}^-$  in decimolar solution

$$[\text{H}^+] = 7 \times 10^{-5} \text{ mole per litre}$$

$$\text{Now, } K_w = [\text{H}^+][\text{OH}^-] \text{ or } 1.0 \times 10^{-14} = 7 \times 10^{-5} \times [\text{OH}^-]$$

$$\therefore [\text{OH}^-] = \frac{1 \times 10^{-14}}{7 \times 10^{-5}} = \mathbf{1.43 \times 10^{-10} \text{ mole per litre}}$$

#### 6. TIPS/Formulae :

For precipitation to occur ionic product  $> K_{sp}$ .

Mixture solution contains 0.1 M  $\text{Ag}^+$  and 0.1 M  $\text{Hg}_2^{2+}$ .

$K_{sp}$  of  $\text{Hg}_2\text{I}_2 = 2.5 \times 10^{-26}$  is much smaller than  $K_{sp}$  of  $\text{AgI}$  which is  $8.5 \times 10^{-17}$ .

$[\text{I}^-]$  concentration needed to precipitate  $\text{Hg}_2\text{I}_2$  is calculated as :

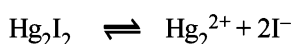

$$[\text{I}^-] = \sqrt{\frac{K_{sp}}{[\text{Hg}_2^{2+}]}} = \sqrt{\frac{2.5 \times 10^{-26}}{0.1}} = \mathbf{5.0 \times 10^{-13} \text{ M}}$$

Similarly,  $[\text{I}^-]$  concentration needed to precipitate  $\text{AgI}$  is :

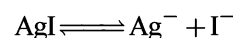

$$[\text{I}^-] = \frac{K_{sp}}{[\text{Ag}^+]} = \frac{8.5 \times 10^{-17}}{0.1} = 8.5 \times 10^{-16} \text{ M}$$



**NOTE :** Since  $[I^-]$  concentration needed to ppt. AgI is smaller than that needed to ppt.  $Hg_2I_2$ , AgI is completely precipitated first. AgI starts precipitation with  $[I^-] = 8.5 \times 10^{-16} M$ . However,  $Hg_2I_2$  starts precipitating with AgI only when molar concentration of  $I^-$  reaches  $5.0 \times 10^{-13} M$ .

$[Ag^+]$  left when  $Hg_2I_2$  begins to ppt. is given by

$$\frac{K_{sp} \text{ of AgI}}{[I^-]_{Hg_2I_2}} = \frac{8.5 \times 10^{-17}}{5.0 \times 10^{-13}} = 1.7 \times 10^{-4} M$$

$$\text{Thus \% } [Ag^+] \text{ left unprecipitated} = \frac{1.7 \times 10^{-4}}{0.1} \times 100 = 0.17\%$$

Hence %  $Ag^+$  precipitated = **99.83%**

7. Let  $x$  be the degree of dissociation of  $PCl_5(g)$ , then

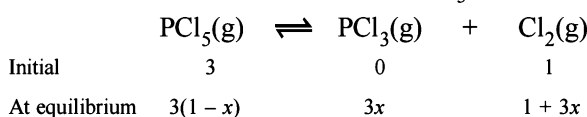

$\therefore$  Total number of moles at equilibrium

$$= 3(1-x) + 3x + 1 + 3x = 3(1+x) + 1$$

Using the gas equation :  $PV = nRT$

$$\therefore n = \frac{PV}{RT}$$

Here,  $P = 2.05 \text{ atm.}$ ,  $V = 100 \text{ litres}$ ,  $R = 0.082 \text{ atm/deg.}$ ,  
 $T = 273 + 227 = 500 K$

$$\therefore n = \frac{2.05 \times 100}{0.082 \times 500} = 5 \quad \therefore 3(1+x) + 1 = 5$$

$$\text{or } 3 + 3x + 1 = 5 \quad \text{or } 3x = 5 - 4 \quad \text{or } x = \frac{1}{3} = 0.333$$

Hence percentage dissociation of  $PCl_5 = 0.333 \times 100 = \mathbf{33.3\%}$

Calculation of  $K_p$  for the reaction :

$$K_p = \frac{[PCl_3][Cl_2]}{[PCl_5]} = \frac{\left[ \frac{3xP}{3(1+x)+1} \right] \left[ \frac{(1+3x)P}{3(1+x)+1} \right]}{\left[ \frac{3(1-x)P}{3(1+x)+1} \right]}$$

$$= \frac{3x(3x+1)}{4+3x} \times \frac{1P}{3(1-x)}$$

$$= \frac{(3x^2+x) \times P}{(4+3x)(1-x)} = \frac{x(3x+1) \times P}{(4+3x)(1-x)}$$

Substituting,  $x = 1/3$  and  $P = 2.05 \text{ atm.}$ , we get

$$K_p = \frac{\frac{1}{3} \left( 3 \times \frac{1}{3} + 1 \right) \times 2.05}{\left( 4 + 3 \times \frac{1}{3} \right) \left( 1 - \frac{1}{3} \right)} = \frac{4.1}{10} = \mathbf{0.41}$$

8. (i)  $N_2 < O_2 < F_2 < Cl_2$   
 i.e.,  $N \equiv N < O = O < F - F < Cl - Cl$

**NOTE:**

As the number of bonds increases the bond length decreases.

So  $N_2 < O_2 < \text{halogens}$ . Among  $F_2$  and  $Cl_2$  bond length of  $Cl_2$  will be higher because of higher atomic radii.

(ii) Among oxyacids of the same element, acidic nature increases with its oxidation number, e.g.,

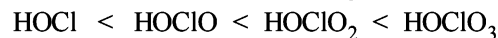

O.N. of Cl    +1            +3            +5            +7

(iii)  $H_2O < CH_3-\ddot{O}H < ^-OH < ^-OCH_3$

Weaker the base stronger is its conjugate acids

$H_3O^+ > CH_3\overset{+}{O}H_2 > H_2O > CH_3OH$  (Decreasing acidic order of the conjugate bases.)

(iv)  $BaO > B_2O_3 > CO_2 > SO_3 > Cl_2O_7$

Basicity increases with increase in oxidation state (Ba = +2, B = +3, C = +4, S = +6, Cl = +7).

9. **TIPS/Formulae :**

For acidic buffer  $pH = -\log K_a + \log \frac{[\text{Salt}]}{[\text{Acid}]}$

Calculation of concentration of HCOOH.

Here,  $c = 0.2 M$ ;  $[H^+] = 6.4 \times 10^{-3}$

$$[H^+] = c\alpha \text{ or } \alpha = \frac{[H^+]}{c} \Rightarrow \alpha = \frac{6.4 \times 10^{-3}}{0.2} = 3.2 \times 10^{-2}$$

**NOTE :** Thus the degree of dissociation of HCOOH is very low which on addition of sodium formate is further suppressed due to common ion effect.

Since the degree of dissociation is very low ( $3.2 \times 10^{-2}$ ), it can be neglected and hence [HCOOH] can be taken as 0.2M.

**Calculation of concentration of  $HCOO^-$ ,  $[HCOO^-]$**

It can be obtained in the following manner :

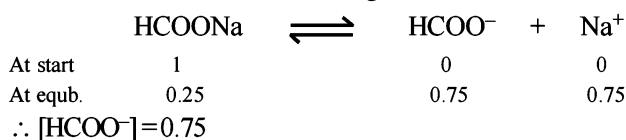

For acidic buffer  $pH = -\log K_a + \log \frac{[\text{Salt}]}{[\text{acid}]}$

$$= -\log 2.4 \times 10^{-4} + \log \frac{0.75}{0.20} = \mathbf{4.19}$$

10.  $A_2(g) + B_2(g) \rightleftharpoons 2AB(g)$



$$\therefore [A_2] = \frac{1-x}{3}, [B_2] = \frac{2-x}{3}, [AB] = \frac{2x}{3}$$

$$\therefore K = \frac{(2x/3)^2}{[(1-x)/3][2-x]/3} = 50$$

On solving we get,  $23x^2 - 75x + 50 = 0$ ;  $x = 2.317$  or  $0.943$   
 The value  $2.317$  is inadmissible because initial concentration of reactants is 2 moles and so  $x = 0.943$

$\therefore$  Moles of AB formed =  $2 \times 0.943 = 1.886$

### 11. Solubility of $Mg(OH)_2$ in water

$$S = 9.57 \times 10^{-3} \text{ g/litre} = \frac{9.57 \times 10^{-3}}{58} = 1.65 \times 10^{-4} \text{ mole/litre}$$

[ $\because$  M for  $Mg(OH)_2 = 58$ ]

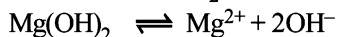

$$K_{sp} = (S)(2S)^2 = 4S^3 = 4(1.65 \times 10^{-4})^3 = 1.8 \times 10^{-11} \text{ approx.}$$

Calculation of solubility of  $Mg(OH)_2$ , say,  $x$ , in  $Mg(NO_3)_2$

or  $[Mg^{2+}] = x + 0.02$ ;  $[OH^-] = x$

$$K_{sp} = [Mg^{2+}][2OH^-]^2 \text{ or } 1.8 \times 10^{-11} = (x + 0.02)(2x)^2$$

Neglecting  $x$  in comparison to  $0.02$  (common ion effect)

$$\Rightarrow 4x^2 = \frac{1.8 \times 10^{-11}}{0.02} = 9 \times 10^{-10} \text{ or } 2x = 3 \times 10^{-5}$$

$$x = 1.5 \times 10^{-5} \text{ moles/litres}$$

$$= 1.5 \times 58 \times 10^{-5} = 8.7 \times 10^{-4} \text{ g/litre.}$$

### 12. (i) Amount of HCl added = 0.20 mole

$$[H^+] = 0.2 \text{ g litre}^{-1}$$

**NOTE :** Added  $H^+$  ions will combine with the acetate ions forming acetic acid with the result concentration of acetate ions will decrease while that of acetic acid will increase.

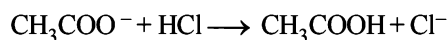

before reaction	1	0.2	1	0
after reaction	0.8	0	1.2	0.2

$\therefore$  Concentration of acetate ions after adding 0.20 mole of HCl.

$$[CH_3COO^-] = 1.0 - 0.2 = 0.8 \text{ mole}$$

Similarly, concentration of acetic acid,

$$[CH_3COOH] = 1.0 + 0.2 = 1.2 \text{ mole}$$

$$\text{Now, } pH = -\log K_a + \log \frac{[\text{Salt}]}{[\text{Acid}]}$$

$$= -\log 1.8 \times 10^{-5} + \log \frac{0.8}{1.2}$$

$$pH = 4.7447 + 0.3010 - 0.4771 = 4.5686$$

### (ii) Amount of HCl added = 0.20 mole

Out of 0.2 mole of  $[H^+]$  added, 0.1 mole will combine with 0.1 mole of  $CH_3COO^-$  forming 0 mole of  $CH_3COOH$ .

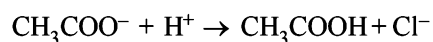

before reaction	0.1	0.2	0.1	0
after reaction	0	0.1	0.2	0.1

$\therefore$  Total concentration of acetic acid  $[CH_3COOH]$

$$= 0.1 + 0.1 = 0.2 \text{ mole}$$

In presence of  $[H^+]$ ,  $CH_3COOH$  will not ionize.

Therefore,  $pH$  of the solution will be due to the presence of  $H^+$  of HCl, i.e.  $0.2 - 0.1 = 0.1$  mole HCl

$$pH = -\log [H^+] = -\log [0.1] = 1$$

### 13. Initial concentration of each gas = 1 mole

Let the No. of moles of  $NO_2$  reacted at equilibrium =  $x$

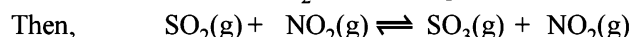

At equilibrium  $(1-x)$   $(1-x)$   $(1+x)$   $(1+x)$

$$\text{Now we know that, } \frac{[SO_3][NO]}{[SO_2][NO_2]} = K_c$$

$$\text{or } \frac{(1+x/V)(1+x/V)}{(1-x/V)(1-x/V)} = 16 \text{ or } \frac{(1+x)^2}{(1-x)^2} = 16 \quad (\because V=1L)$$

$$\text{or } \frac{1+x}{1-x} = 4 \text{ or } 1+x = 4-4x \text{ or } 5x = 3$$

$$x = \frac{3}{5} = 0.6$$

$\therefore$  Thus the concentration of NO at equilibrium =  $1+x = 1+0.6 = 1.6$  moles

Concentration of  $NO_2$  at equilibrium

$$= 1-x = 1-0.6 = 0.4 \text{ moles}$$

### 14. (i) $N_2O_4 \rightleftharpoons 2NO_2$

Before dissociation	1	0
After dissociation	$1-\alpha$	$2\alpha$

$$\therefore \text{ Total moles} = 1 - \alpha + 2\alpha = 1 + \alpha$$

$$\therefore K_p = \frac{(p_{NO_2})^2}{p_{N_2O_4}} = \frac{\left(\frac{2\alpha}{1+\alpha} \times P\right)^2}{\left(\frac{1-\alpha}{1+\alpha} \times P\right)}$$

where  $P$  is total pressure

$$K_p = \frac{\left(\frac{2 \times 0.25 \times 1}{1 + 0.25}\right)^2}{\left(\frac{1 - 0.25}{1 + 0.25} \times 1\right)} = 0.266 \text{ atm} \quad [\because \alpha = 0.25]$$

$$(ii) K_p = \frac{4\alpha^2 P^2 \times (1+\alpha)}{(1+\alpha)^2 (1-\alpha) \times P} = \frac{4\alpha^2 P}{(1+\alpha)(1-\alpha)}$$

$$0.266 = \frac{4\alpha^2 \times 0.1}{1-\alpha^2} \Rightarrow \alpha = 0.64$$

$\therefore$  Percentage dissociation = 63 %

### 15. TIPS/Formulae :

$$pH = pK_a + \log \left( \frac{[\text{Salt}]}{[\text{Acid}]} \right)$$

If  $x$  moles of HCl are added then they will combine with NaCN to form  $x$  moles of very weak acid HCN.

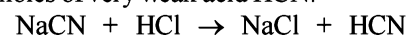

At equilibrium :  $(0.01-x)$   $x$   $x$   $x$

For an acidic buffer,

$$pH = -\log K_a + \log \frac{[\text{Salt}]}{[\text{Acid}]}$$

$$\therefore 8.5 = -\log 4.1 \times 10^{-10} + \log \left( \frac{0.01 - x}{x} \right)$$

$$\text{or } 8.5 = (10 - \log 4.1) + \log \left( \frac{0.01 - x}{x} \right)$$

$$\log \left( \frac{0.01 - x}{x} \right) = -0.8872 \quad [\log 4.1 = 0.6128]$$

$$\frac{0.01 - x}{x} = 0.1296$$

$$x = 8.85 \times 10^{-3} \text{ M} = \mathbf{8.85 \times 10^{-3} \text{ moles of HCl}}$$

16. **NOTE :** Since the reaction is carried out at constant volume, change in partial pressure of a species will be directly proportional to the change in its amount. Hence, we can write

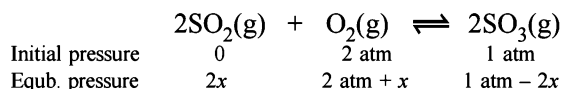

Where  $2x$  is the change in partial pressure of  $\text{SO}_3$  at equilibrium.

Substituting the expression of partial pressure in the expression. For  $K_p$ , we get

$$K_p = \frac{(p_{\text{SO}_3})^2}{(p_{\text{SO}_2})^2 (p_{\text{O}_2})}$$

$$\text{or } 900 \text{ atm}^{-1} = \frac{(1 \text{ atm} - 2x)^2}{(2x)^2 (2 \text{ atm} + x)}$$

Assuming  $x$  is very small as compared to 1

$$900 \text{ atm}^{-1} = \frac{1 \text{ atm}^2}{(4x^2) (2 \text{ atm})}$$

On usual calculations,  $x = 0.0118 \text{ atm}$

Thus  $p_{\text{SO}_2} = 2x = 2 \times 0.0118 \text{ atm} = \mathbf{0.0236 \text{ atm}}$

$p_{\text{O}_2} = 2 \text{ atm} + x = 2 + 0.0118 = \mathbf{2.0118 \text{ atm}}$

$p_{\text{SO}_3} = 1 \text{ atm} - 2x = 1 - 0.0236 = \mathbf{0.9764 \text{ atm}}$

17. **TIPS/Formulae :**

$$p(\text{OH}) \text{ for basic buffer} = pK_b + \log \left( \frac{[\text{Salt}]}{[\text{Base}]}\right)$$

We know that

$$p\text{OH} = pK_b + \log \frac{[\text{Salt}]}{[\text{Base}]} \quad \text{or } -\log 1.8 \times 10^{-5} + \log \frac{0.25}{0.05}$$

$$p\text{OH} = 5 - \log 1.8 + \log 5 = 5.6989 - 0.2552$$

$$-\log [\text{OH}^-] = 5.4437; \quad \log [\text{OH}^-] = -5.4437$$

$$[\text{OH}^-] = 3.5999 \times 10^{-6} \quad [\text{Taking antilog}]$$

$$K_{sp} \text{ for } \text{Mg}(\text{OH})_2 = [\text{Mg}^{2+}] [\text{OH}^-]^2$$

$$6 \times 10^{-10} = [\text{Mg}^{2+}] [3.5999 \times 10^{-6}]^2$$

$$[\text{Mg}^{2+}] = \frac{6 \times 10^{-10}}{12.9598 \times 10^{-12}} = 0.4629 \times 10^2$$

= **46.29 mole ion per litre**

$$K_{sp} \text{ for } \text{Al}(\text{OH})_3 = [\text{Al}^{3+}] [\text{OH}^-]^3$$

$$6 \times 10^{-32} = [\text{Al}^{3+}] (3.5999 \times 10^{-6})^3$$

$$[\text{Al}^{3+}] = \frac{6 \times 10^{-32}}{(3.5999 \times 10^{-6})^3} = \mathbf{1.286 \times 10^{-15} \text{ mol ion/l}}$$

18. Let the total number of moles of all gases at equilibrium point =  $n$

$$P = 4.92 \text{ atm.}$$

$$V = 5 \text{ l}$$

$$R = 0.0821 \text{ atm. l mol}^{-1} \text{ K}^{-1}$$

$$T = 273 + 327 = 600 \text{ K}$$

$$\text{By applying the formula } PV = nRT$$

$$n = \frac{PV}{RT} = \frac{4.92 \times 5}{0.0821 \times 600} = 0.5 \text{ moles}$$

- (i) *Calculation of the number of moles of the individual gases at equilibrium point.*

No. of moles of  $\text{CH}_3\text{OH}$  formed = 0.1 (Given)

$\therefore$  No. of moles of  $\text{CO}$  (also) = 0.1

[ $\therefore$  moles of  $\text{CO}$  = moles of  $\text{CH}_3\text{OH}$  formed]

Hence No. of moles of  $\text{H}_2 = 0.5 - (0.1 + 0.1) = 0.3$

$\therefore$  Molar concentration of various species will be

$$[\text{CH}_3\text{OH}] = [\text{CO}] = \frac{0.1}{5} = 0.02; \quad [\text{H}_2] = \frac{0.3}{5} = 0.06$$

$$\therefore K_c = \frac{[\text{CH}_3\text{OH}]}{[\text{CO}][\text{H}_2]^2} = \frac{0.02}{0.02 \times (0.06)^2} = \mathbf{277.78 \text{ mol}^{-2} \text{ l}^2}$$

- (ii) *Calculation of  $K_p$ .* We know that

$$K_p = K_c \times (RT)^{\Delta n} = 277.78 \times (0.0821 \times 600)^{-2}$$

$$(\Delta n = 1 - 3 = -2)$$

$$= \frac{277.78}{2426.54} = \mathbf{0.1144 \text{ atm}^{-2}}$$

19. **Case I.**  $\text{CH}_3\text{COOH} \rightleftharpoons \text{CH}_3\text{COO}^- + \text{H}^+$

At start	1	0	0
At equil.	$1 - \alpha$	$\alpha$	$\alpha$

$$[\text{H}^+] = c\alpha = c \sqrt{\frac{K_a}{c}} = \sqrt{K_a c}$$

$$\therefore [\text{H}^+] = \sqrt{1.8 \times 10^{-5} \times 1} = 4.24 \times 10^{-3} \text{ M}$$

$$\text{Thus } pH = -\log \text{H}^+ = -\log 4.24 \times 10^{-3} = \mathbf{2.3724}$$

**Case II.** *pH after dilution* = 2  $\times$  original *pH*

$$= 2 \times 2.3724 = 4.7448$$

Let conc. after dilution =  $c_1$

and degree of dissociation =  $\alpha_1$

Since  $pH = -\log [\text{H}^+]$

$$4.7448 = -\log [\text{H}^+]$$

$[H^+] = 1.8 \times 10^{-5} = c_1 \alpha_1 \therefore c_1 \alpha_1 = 1.8 \times 10^{-5}$   
Dissociation constant

$$\text{Since } K_a = \frac{[CH_3COO^-][H^+]}{[CH_3COOH]}$$

$$= \frac{(c_1 \alpha_1)(c_1 \alpha_1)}{c_1 [1 - \alpha_1]} = \frac{c_1 \alpha_1^2}{(1 - \alpha_1)}$$

$$1.8 \times 10^{-5} = \frac{1.8 \times 10^{-5} \times \alpha_1}{1 - \alpha_1} \therefore \alpha_1 = 0.5$$

Substituting the value of  $\alpha_1$  in the following relation

$$c_1 \alpha_1 = [H^+]; c_1 \times 0.5 = 1.8 \times 10^{-5}$$

$$c_1 = \frac{1.8 \times 10^{-5}}{0.5} = 3.6 \times 10^{-5} \text{ M}$$

Since the number of moles of  $CH_3COOH$  before and after dilution will be same

$\therefore$  Mole of  $CH_3COOH$  before dilution = Mole of  $CH_3COOH$  after dilute

( $\because$  Mole =  $M \times V_{\text{in litre}}$ )

$$1 \times 1 = 3.6 \times 10^{-5} \times V \Rightarrow V = 2.78 \times 10^4 \text{ litres}$$

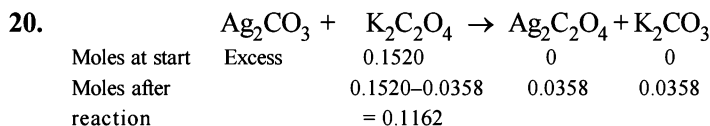

Molar concentration of  $K_2C_2O_4$  or  $C_2O_4^{2-}$  left unreacted

$$= \frac{0.1162}{0.5} = 0.2324 \text{ moles } l^{-1} \quad [\because 500 \text{ ml} = 0.5 \text{ L}]$$

$[K_2CO_3] = [CO_3^{2-}]$  at equilibrium

$$= \frac{0.0358}{0.5} = 0.07156 \text{ moles } l^{-1}$$

Given that  $K_{sp}$  for  $Ag_2C_2O_4 = 1.29 \times 10^{-11} \text{ mol}^3 l^{-3}$  at  $25^\circ C$

$$\text{So, } [Ag^+]^2 [C_2O_4^{2-}] = 1.29 \times 10^{-11}$$

$$\text{or } [Ag^+]^2 \times 0.2324 = 1.29 \times 10^{-11}$$

$$\text{Hence } [Ag^+]^2 = \frac{1.29}{0.2324} \times 10^{-11}$$

Then  $K_{sp}$  for  $Ag_2CO_3$

$$= [Ag^+]^2 [CO_3^{2-}] = \frac{1.29 \times 10^{-11}}{0.2324} \times 0.0716$$

$$= 3.974 \times 10^{-12} \text{ mol}^3 l^{-3}$$

21. Case I. Write the concerned chemical reaction

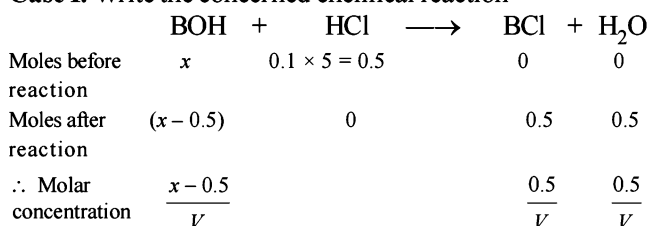

Since the solution represents a basic buffer, following Hendersen equation can be applied.

$$pOH = -\log K_b + \log \frac{[\text{Salt}]}{[\text{Base}]}$$

$$14 - 10.04 = -\log K_b + \log \frac{0.5}{(x - 0.5)} \quad \dots(i)$$

Case II.

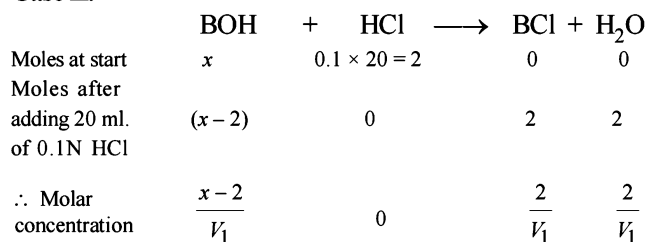

Again the solution is acting as basic buffer

$$\therefore pOH = -\log K_b + \log \frac{[\text{Salt}]}{[\text{Base}]}$$

$$14 - 9.14 = -\log K_b + \log \frac{2}{(x - 2)} \quad \dots(ii)$$

Divide (i) by (ii),

$$\frac{3.96}{4.86} = \frac{0.5}{(x - 0.5)} \times \frac{(x - 2)}{2} \Rightarrow x = 0.088 \text{ mol } l^{-1}$$

Substituting x in (i) and solving for  $K_b$

$$3.96 = -\log K_b + \log \frac{0.5}{0.088 - 0.5}$$

$$K_b = 1.828 \times 10^{-5}$$

22. Let the solubility of  $Ca(OH)_2$  in pure water = S moles/litre

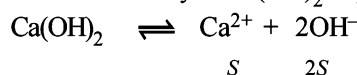

Then  $K_{sp} = [Ca^{2+}][OH^-]^2$

$$4.42 \times 10^{-5} = S \times (2S)^2; 4.42 \times 10^{-5} = 4S^3$$

$$S = 2.224 \times 10^{-2} = 0.0223 \text{ moles litre}^{-1}$$

$\therefore$  No. of moles of  $Ca^{2+}$  ions in 500 ml. of solution =  $\lambda$

$$= \frac{0.0223 \times 500}{4000} = 0.01115$$

**NOTE THIS STEP:** Now when 500 ml. of saturated solution is mixed with 500 ml of 0.4M NaOH, the resultant volume is 1000 ml. The molarity of  $OH^-$  ions in the resultant solution would therefore be 0.2 M.

$$\therefore [Ca^{2+}] = \frac{K_{sp}}{[OH^-]^2} = \frac{4.42 \times 10^{-5}}{(0.2)^2} = 0.001105 \text{ M}$$

Thus, No. of moles of  $Ca^{2+}$  or  $Ca(OH)_2$  precipitated

$$= 0.01115 - 0.001105 = 0.010045$$

Mass of  $Ca(OH)_2$  precipitated

$$= 0.010045 \times 74 = 0.7433 \text{ g} = 743.3 \text{ mg}$$

$$[\text{mole wt. of } Ca(OH)_2 = 74]$$

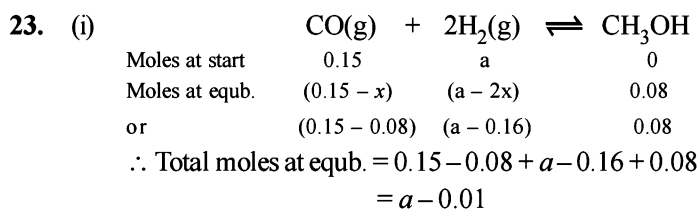

Total moles at equilibrium can also be calculated from the following relation

$$n = \frac{PV}{RT} = \frac{8.5 \times 2.5}{0.0821 \times 750} = 0.345$$

$$\therefore 0.345 = a - 0.01 \quad [\text{Comparing (i) and (ii)}]$$

$$\text{or } a = 0.355$$

Thus, Moles of CO at equilibrium =  $0.15 - 0.08 = 0.07$

Moles of  $\text{H}_2$  at equilibrium =  $0.355 - 0.16 = 0.195$

Moles of  $\text{CH}_3\text{OH}$  at equilibrium = 0.08

Substituting the values in the relation,

$$K_c = \frac{[\text{CH}_3\text{OH}]}{[\text{H}_2]^2 [\text{CO}]} = \frac{0.08/2.5}{(0.195/2.5)^2 \times (0.07/2.5)}$$

$$= 187.85 \text{ mole}^{-2} \text{ litre}^2 \quad [\because V = 2.5 \text{ L}]$$

Calculation of  $K_p$

$$K_p = K_c (RT)^{\Delta n} = 187.85 \times (0.0821 \times 750)^{-2} = 0.05 \text{ atm}^{-2}$$

$$[\because \Delta n = -2]$$

(ii) Calculation of final pressure when there is no reaction

Moles of CO = 0.15; Moles of  $\text{H}_2$  = 0.355

$\therefore$  Total moles =  $0.15 + 0.355 = 0.505$

$$PV = nRT$$

$$P \times 2.5 = 0.505 \times 0.0821 \times 750 \Rightarrow P = 12.438 \text{ atm.}$$

24. Volume of blood = 10 ml. (given)

$[\text{H}_2\text{CO}_3]$  in blood = 2 M (given)

$[\text{NaHCO}_3]$  to be added = 5 M (given)

Let volume of  $\text{NaHCO}_3$  added in 10 ml blood = V ml

$$\therefore [\text{H}_2\text{CO}_3] \text{ in blood mixture} = \frac{2 \times 10}{(V + 10)}$$

$$[\text{NaHCO}_3] \text{ in blood mixture} = \frac{5 \times V}{(V + 10)}$$

$$\therefore pH = pK_a + \log \frac{[\text{Salt}]}{[\text{Acid}]}$$

$$\text{or } 7.4 = -\log 7.8 \times 10^{-7} + \log \frac{5V/(V + 10)}{20/(V + 10)} \therefore V = 78.36 \text{ ml}$$



$$\text{Further, } \text{HS}^- \rightleftharpoons \text{H}^+ + \text{S}^{2-} \therefore K_2 = \frac{[\text{H}^+][\text{S}^{2-}]}{[\text{HS}^-]}$$

Dissociation constant of  $\text{H}_2\text{S}$ ,  $K = K_1 \times K_2$   
*i.e.*  $K = 1 \times 10^{-7} \times 1.3 \times 10^{-13} = 1.3 \times 10^{-20}$

Now we know that

$$K_{sp} = [\text{M}^{2+}][\text{S}^{2-}] \Rightarrow 6 \times 10^{-21} = 0.05 \times [\text{S}^{2-}]$$

$$[\text{S}^{2-}] = \frac{6 \times 10^{-21}}{0.05} = 1.2 \times 10^{-19}$$

Substituting the various values in the following relation

$$K = \frac{[\text{H}^+]^2 [\text{S}^{2-}]}{[\text{H}_2\text{S}]}$$

$$1.3 \times 10^{-20} = \frac{[\text{H}^+]^2 [1.2 \times 10^{-19}]}{0.1} \therefore [\text{H}_2\text{S}] = 0.1 \text{ M}$$

$$[\text{H}^+]^2 = \frac{1.3 \times 10^{-20} \times 0.1}{1.2 \times 10^{-19}}$$

$$[\text{H}^+] = \sqrt{\frac{1.3 \times 10^{-20} \times 0.1}{1.2 \times 10^{-19}}} = 1.04 \times 10^{-1}$$

$$pH = -\log [\text{H}^+]; pH = -\log (1.04 \times 10^{-1})$$

$$= 1.0 - \log 1.04 = 1.0 - 0.017 = 0.983$$

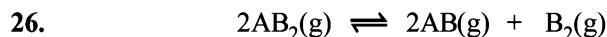

Initial mole	1	0	0
Moles at equb	$1 - x$	$x$	$\frac{x}{2}$

$$\text{Total moles at equb.} = 1 - x + x + \frac{x}{2} = 1 + \frac{x}{2} = \frac{2 + x}{2}$$

$$p_{\text{AB}_2} = \frac{(1 - x)}{2 + x/2} P = \frac{2(1 - x)}{2 + x} P$$

$$p_{\text{AB}} = \frac{x}{2 + x/2} P = \frac{2x}{2 + x} P$$

$$p_{\text{B}_2} = \frac{x/2}{2 + x/2} P = \frac{x}{2 + x} P$$

$$\therefore K_p = \frac{(p_{\text{AB}})^2 (p_{\text{B}_2})}{(p_{\text{AB}_2})^2} = \frac{\left(\frac{2x}{2+x} P\right)^2 \left(\frac{x}{2+x} P\right)}{\left[\frac{2(1-x)}{2+x} P\right]^2}$$

$$= \frac{x^3 P}{(2+x)(1-x)^2}$$

$$K_p \approx \frac{x^3}{2} P \quad \text{or } x = \left[\frac{2K_p}{P}\right]^{1/3}$$

27. TIPS/Formulae :

Consider common ion effect

Conc. of  $\text{Ag}^+$  ions = Conc. of  $\text{AgNO}_3 = 0.03 \text{ M}$

Most of these  $\text{Ag}^+$  ions will be present in the form of  $[\text{Ag}(\text{CN})_2]^-$ .

$0.03 \text{ M AgNO}_3$  requires  $2 \times 0.03 \text{ M}$   
 $= 0.06 \text{ M CN}^-$  to form  $[\text{Ag}(\text{CN})_2]^-$

∴ Conc. of free  $\text{CN}^-$  at equilibrium will be  $0.1 - 0.06 = 0.04 \text{ M}$

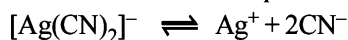

$$\therefore K = \frac{[\text{Ag}^+][\text{CN}^-]^2}{[\text{Ag}(\text{CN})_2]^-}; 4.0 \times 10^{-9} = \frac{[\text{Ag}^+][0.04]^2}{0.03}$$

$$[\text{Ag}^+] = \frac{4.0 \times 10^{-19} \times 0.03}{(0.04)^2} = 7.5 \times 10^{-18} \text{ M}$$

28. For ammonium formate which is a salt of weak acid with weak base, we know that

$$pH = \frac{1}{2}[pK_w + pK_a - pK_b] = \frac{1}{2}[14 + 3.8 - 4.8] = 6.5$$

29.  $pK_b = 4.70$ , ∴  $K_b = 10^{-4.7}$

Now we know that

$$[\text{OH}^-] = \sqrt{K_b \times c}$$

$$\therefore [\text{OH}^-] = \sqrt{10^{-4.7} \times 0.5} = 3.158 \times 10^{-3} \text{ M}$$

Now we know that

$$p\text{OH} = -\log[\text{OH}^-]$$

$$p\text{OH} = -\log 3.158 \times 10^{-3} = 2.5$$

$$\text{or, } pH = 14 - 2.5 = 11.5$$

30. The concerned chemical reaction is

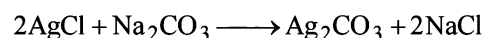

Calculation of  $[\text{Ag}^+]$  left in the solution :

$$K_{sp}(\text{Ag}_2\text{CO}_3) = [\text{Ag}^+]^2 [\text{CO}_3^{2-}]$$

$$[\text{Ag}^+] = \sqrt{\frac{8.2 \times 10^{-12}}{1.5}} = 2.34 \times 10^{-6} \text{ M}$$

Concentration of  $\text{Cl}^-$  left =  $0.0026 \text{ g/l}$

$$= \frac{0.0026}{35.5} \text{ mol/l} = 7.33 \times 10^{-5} \text{ M}$$

$$\therefore K_{sp}(\text{AgCl}) = [\text{Ag}^+][\text{Cl}^-] = (2.34 \times 10^{-6})(7.33 \times 10^{-5}) = 1.71 \times 10^{-10}$$

31. Given  $K_a = 1 \times 10^{-5}$

$$\therefore pK_a = 5$$

The two conditions when colour indicator will be visible are derived by

$$pH = pK_a + \log \frac{[\text{In}^-]}{[\text{HIn}]}$$

$$(i) \quad pH = 5 + \log 10 = 6$$

$$(ii) \quad pH = 5 + \log 0.1 = 4$$

Thus minimum change in  $pH = 2$

32. For  $\text{AgCl}$ ;  $\text{AgCl} \rightleftharpoons \text{Ag}^+ + \text{Cl}^-$

$$\therefore K_{sp} = [\text{Ag}^+][\text{Cl}^-] \quad \dots (i)$$

Again it is given that

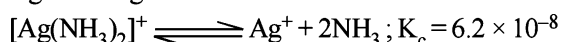

$$K_f = \frac{1}{6.2 \times 10^{-8}} = \frac{10^8}{6.2}$$

$$\therefore K_f = \frac{[\text{Ag}(\text{NH}_3)_2]^+}{[\text{Ag}^+][\text{NH}_3]^2} \quad \text{or } [\text{Ag}^+] = \frac{[\text{Ag}(\text{NH}_3)_2]^+}{K_f[(\text{NH}_3)_2]}$$

**NOTE THIS STEP :** Since the formation constant of the complex is very high, most of the  $[\text{Ag}^+]$  which dissolves must be converted into complex and each  $\text{Ag}^+$  dissolved also requires dissolution of  $\text{Cl}^-$ .

$$\therefore [\text{Cl}^-] = [\text{Ag}(\text{NH}_3)_2]^+ \text{ and let it be } c \text{ M}$$

Equation (i) becomes

$$K_{sp} = \frac{[\text{Ag}(\text{NH}_3)_2]^+ \times c}{K_f[\text{NH}_3]^2} \Rightarrow K_{sp} = \frac{c}{K_f[1]^2} \times c$$

$$c^2 = K_{sp} \times K_f[1]^2 = 1.8 \times 10^{-10} \times \frac{10^8}{6.2} \times (1)^2$$

$$c^2 = \frac{1.8 \times 10^{-2}}{6.2} = 0.2903 \times 10^{-2}$$

$$\text{or } c = 0.538 \times 10^{-1} = 0.0538 \text{ M}$$

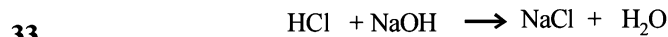

$$\text{Meq. before reaction} \quad 200 \times 10^{-2} \quad 300 \times 10^{-2}$$

$$\text{Meq. after reaction} \quad 0 \quad 100 \times 10^{-2} \quad 200 \times 10^{-2} \quad 200 \times 10^{-2}$$

$pH$  of  $\text{HCl} = 2$ ,  $pH$  of  $\text{NaOH} = 12$

$$\therefore [\text{HCl}] = 10^{-2} \text{ M}, \therefore [\text{NaOH}] = 10^{-2} \text{ M}$$

$$\therefore [\text{OH}^-] = \frac{100 \times 10^{-2}}{500} = 2 \times 10^{-3} \text{ or } p[\text{OH}] = -\log(2 \times 10^{-1})$$

$$\therefore p\text{OH} = 2.6989; \therefore pH = 11.3010 \quad [pH = 14 - p(\text{OH})]$$

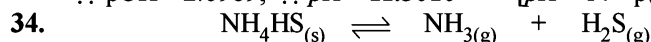

$$\text{Initial moles} \quad \frac{3.06}{51} \quad 0 \quad 0$$

$$\text{Moles at eq.} \quad \frac{3.06}{51} \times \frac{70}{100} \quad \frac{3.06}{51} \times \frac{30}{100} \quad \frac{3.06}{51} \times \frac{30}{100}$$

Given  $V = 2$  litre,  $T = 300\text{K}$ ,  $\Delta n = 2 - 0 = 2$

$$\therefore K_c = [\text{NH}_3][\text{H}_2\text{S}] = \frac{3.06 \times 30}{51 \times 100 \times 2} \times \frac{3.06 \times 30}{51 \times 100 \times 2} = 8.1 \times 10^{-5} \text{ mol}^2 \text{ litre}^{-2}$$

$$\text{Also } K_p = K_c(RT)^{\Delta n} = 8.1 \times 10^{-5} (0.082 \times 300)^2 = 4.90 \times 10^{-2} \text{ atm}^2$$

**NOTE :** Addition of more  $\text{NH}_4\text{HS}$  on this equilibrium will cause no effect because concentration of  $\text{NH}_4\text{HS}$  is not involved in formula of  $K_p$  or  $K_c$ .

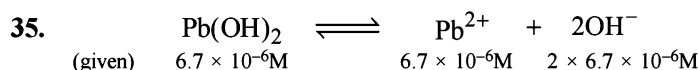

$$\therefore K_{sp} = [\text{Pb}^{2+}][\text{OH}^-]^2 = (6.7 \times 10^{-6})(2 \times 6.7 \times 10^{-6})^2 = 1.203 \times 10^{-15}$$

The buffer solution  $pH = 8$  (given)

$$\therefore p\text{OH} = 6 \text{ or } [\text{OH}^-] = 10^{-6}$$

Thus in this buffer we have,  $[\text{Pb}^{2+}][\text{OH}^-]^2 = 1.203 \times 10^{-15}$

$$\text{or } [\text{Pb}^{2+}] \times [10^{-6}]^2 = 1.203 \times 10^{-15}$$

$$\therefore [\text{Pb}^{2+}] = 1.203 \times 10^{-3} \text{ mol litre}^{-1}$$

36. Amount of  $\text{SO}_2$  in atmosphere =  $\frac{10}{10^6} = 10 \times 10^{-6}$

Molar concentration of  $\text{SO}_2$  present in water  
 = Amount of  $\text{SO}_2 \times$  Solubility of  $\text{SO}_2$  in water  
 =  $10 \times 10^{-6} \times 1.3653 \text{ mole L}^{-1} = 1.3653 \times 10^{-5} \text{ M}$

Writing the concerned chemical equation

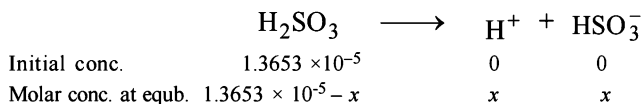

Therefore  $K_a = \frac{x^2}{(1.3653 \times 10^{-5} - x)}$

$\Rightarrow 10^{-1.92} = \frac{x^2}{(1.3653 \times 10^{-5} - x)}$   
 ( $pK_a = 1.92, \therefore K_a = 10^{-1.92}$ )

$\Rightarrow 1.2 \times 10^{-2} = \frac{x^2}{(1.3653 \times 10^{-5} - x)}$

$x^2 = 1.2 \times 10^{-2} (1.3653 \times 10^{-5} - x)$  On solving,  $x = 1.364 \times 10^{-5}$

Therefore,  $pH = -\log(1.364 \times 10^{-5}) = 4.865$

37. (i) The volume being doubled by mixing the two solutions, the molarity of each component will be halved i.e.  $[\text{CH}_3\text{COOH}] = 0.1 \text{ M}$ ,  $[\text{HCl}] = 0.1 \text{ M}$ .

**NOTE:**

HCl being a strong acid will remain completely ionised and hence  $\text{H}^+$  ion concentration furnished by it will be 0.1 M. This would exert common ion effect on the dissociation of acetic acid, (a weak acid.)

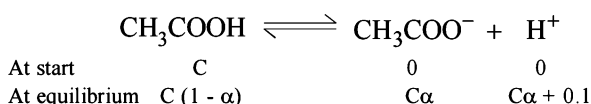

$$K_a = \frac{C\alpha(C\alpha + 0.1)}{C(1 - \alpha)} = \frac{C\alpha^2 + 0.1\alpha}{(1 - \alpha)}$$

Since  $\alpha$  is very very small,  $C\alpha^2$  can be neglected and  $1 - \alpha$  can be taken as unity

$\therefore K_a = 0.1 \alpha$

or  $\alpha = \frac{K_a}{0.1} = \frac{1.75 \times 10^{-5}}{0.1} = 1.75 \times 10^{-4}$

$[\text{H}^+]_{\text{Total}} = 0.1 + C\alpha$ ,

$C\alpha$  is negligible as compared to 0.1.

$\therefore [\text{H}^+]_{\text{Total}} = 0.1 \quad \therefore pH = 1$

- (ii)  $6 \text{ g NaOH} = \frac{6}{40} = 0.15 \text{ mol}$

0.1 mole of NaOH will be consumed by 0.1 mole of HCl. Thus, 0.05 mole of NaOH will react with acetic acid according to the equation.

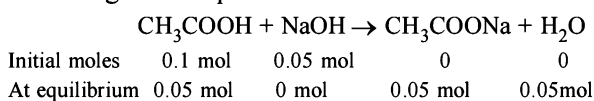

Thus, solution of acetic acid and sodium acetate will become acidic buffer. So pH of the buffer will be

$$pH = pK_a + \log \frac{[\text{salt}]}{[\text{acid}]}$$

$$= -\log(1.75 \times 10^{-5}) + \log 1 = 4.75$$

### 38. TIPS/Formulae :

Higher the value of dipole-dipole interaction higher is b.p. Higher value of  $K_b$  of a solvent suggests larger polarity of solvent molecules which in turn leads to higher dipole – dipole interaction implies higher boiling point due to dipole – dipole interaction. Therefore, the correct order of  $K_b$  values of the three given solvents is

Mathematically  $K_b = \frac{M_A R T_b^2}{\Delta H_{\text{vap}} \times 1000}$

or  $K_b \propto T_b$  (b.pt.)

Solvents	Boiling point	$K_b$ values
X	100°C	0.63
Y	27°C	0.53
Z	283°C	0.98

### G. Comprehension Based Questions

1. (a) Let the heat capacity of insulated beaker be C. Mass of aqueous content in expt. 1 =  $(100 + 100) \times 1 = 200 \text{ g}$   
 $\Rightarrow \pm$  Total heat capacity =  $(C + 200 \times 4.2) \text{ J/K}$   
 Moles of acid, base neutralised in expt. 1 =  $0.1 \times 1 = 0.1$   
 $\Rightarrow$  Heat released in expt. 1 =  $0.1 \times 57 = 5.7 \text{ KJ} = 5.7 \times 1000 \text{ J}$   
 $\Rightarrow 5.7 \times 1000 = (C + 200 \times 4.2) \times \Delta T$   
 $5.7 \times 1000 = (C + 200 + 4.2) \times 5.7$   
 $\Rightarrow (C + 200 \times 4.2) = 1000$   
 In second experiment,  
 $n_{\text{CH}_3\text{COOH}} = 0.2, n_{\text{NaOH}} = -0.1$   
 Total mass of aqueous content = 200 g  
 $\Rightarrow$  Total heat capacity =  $(C + 200 \times 4.2) = 1000$   
 $\Rightarrow$  Heat released =  $1000 \times 5.6 = 5600 \text{ J}$ .  
 Overall, only 0.1 mol of  $\text{CH}_3\text{COOH}$  undergo neutralization.  
 $\Rightarrow \Delta H_{\text{neutralization}}$  of  $\text{CH}_3\text{COOH} = \frac{-5600}{0.1}$   
 $= -56000 \text{ J/mol}$   
 $= -56 \text{ KJ/mol}$ .  
 $\Rightarrow \Delta H_{\text{neutralization}}$  of  $\text{CH}_3\text{COOH} = 57 - 56 = 1 \text{ KJ/mol}$
2. (b) Final solution contain 0.1 mole of  $\text{CH}_3\text{COOH}^2$  and  $\text{CH}_3\text{COONa}$  each. Hence it is a buffer solution.

$$pH = pK_a + \log \frac{[\text{CH}_3\text{COO}^-]}{[\text{CH}_3\text{COOH}]}$$

$$= 5 - \log 2 + \log \frac{0.1}{0.1} = 4.7$$

3. (b)

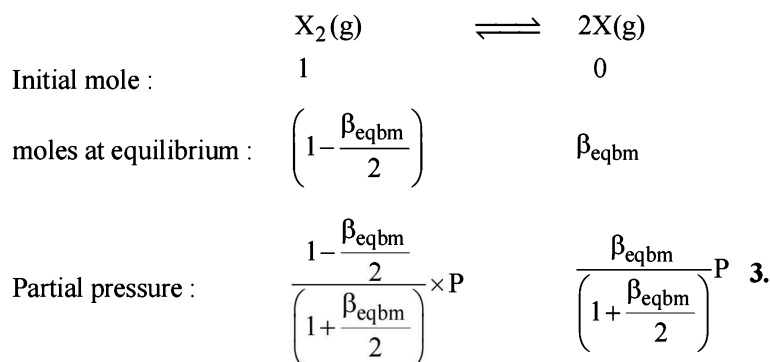

$$\therefore K_p = \frac{(P_x)^2}{P_{X_2}} = \frac{\beta_{\text{eqbm}}^2 P}{\left(1 - \frac{\beta_{\text{eqbm}}}{2}\right)^2}$$

$$\therefore K_p = \frac{4\beta_{\text{eqbm}}^2 P}{\left(4 - \beta_{\text{eqbm}}^2\right)}$$

Since  $P = 2$  bar

$$\text{So, } K_p = \frac{8\beta_{\text{eqbm}}^2}{\left(4 - \beta_{\text{eqbm}}^2\right)}$$

4. (c)

(A) Correct statement.

As on decrease in pressure reaction move in direction where no. of gaseous molecules increase.

(B) Correct statement

At the start of reaction  $Q_p < K_p$  so dissociation of  $X_2$  take place spontaneously.

(C) Incorrect statement as

$$K_p = \frac{8\beta_{\text{eq}}^2}{4 - \beta_{\text{eq}}^2} = \frac{8 \times (0.7)^2}{4 - (0.7)^2} > 1$$

**H. Assertion & Reason Type Questions**

1. (d) The statement-1 is clearly wrong in context to Le-Chatelier's principle, which states that "increase in temperature shifts the equilibrium in the forward direction of those reactions which proceed with absorption of heat (**endothermic reactions**), and in the backward direction of those reactions which proceed with the evolution of heat (**exothermic reactions**)."  
Statement -2 is clearly true again according to Le-Chatelier principle.

2. (c) **TIPS/Formulae :**

Among oxyacids, the acidic character increases with increase in oxidation state of the central atom.

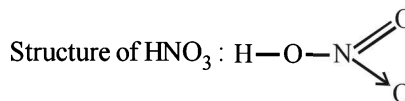
O.S. of N in  $\text{HNO}_3 = +5$ O.S. of N in  $\text{HNO}_2 = +3$ thus  $\text{HNO}_3$  stronger than  $\text{HNO}_2$ . Hence assertion is correct.Structure of  $\text{HNO}_2$  :  $\text{O}-\text{H}-\text{N}=\text{O}$ ;

The assertion is true but the reason is wrong as can be clearly seen from the above structures.

3. (d) We know that for every chemical reaction at equilibrium, Gibb's free energy ( $\Delta G = 0$ ) is zero. However standard Gibb's free energy ( $\Delta G^\circ$ ) may or may not be zero. Thus statement 1 is False.

For a spontaneous reaction, at constant temperature and pressure, the reaction proceeds in the direction in which  $\Delta G < 0$  i.e. in the direction of decreasing Gibb's energy (G) so the statement 2 is True.

Thus the only such option is (d) which is correct answer.

**I. Integer Value Correct Type**

- 1.
- $\text{HA} + \text{NaOH} \longrightarrow \text{NaA} + \text{H}_2\text{O}$

At the end point, the solution contains only NaA whose concentration is  $0.1/2 = 0.05$  MSince the salt NaA is formed by strong alkali (NaOH) and weak acid HA (indicated by its low  $K_a$  value), its  $pH$  can be evaluated by the following relation.

$$pH = \frac{1}{2}(pK_w + pK_a + \log C)$$

$$= \frac{1}{2}(14 + 5.3010 + (-1.3010)) = 9$$

2. pH of sodium salt of weak acid

$$= \frac{1}{2}(pK_w + pK_a + \log C) = \frac{1}{2}(14 + 4 - 2) = 8$$

3. KCN,  $\text{K}_2\text{CO}_3$  and LiCN are the salts of weak acid and strong base. So, their aqueous solutions turns red litmus paper blue.
4. Diprotic acids are  $\text{H}_2\text{SO}_4$ ,  $\text{H}_3\text{PO}_3$ ,  $\text{H}_2\text{CO}_3$ ,  $\text{H}_2\text{S}_2\text{O}_7$ ,  $\text{H}_2\text{CrO}_4$  and  $\text{H}_2\text{SO}_3$ .
5. 7

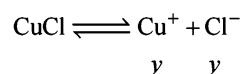
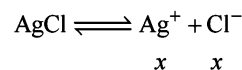
Let the solubility of AgCl is  $x$  mol litre<sup>-1</sup> and that of CuCl is  $y$  mol litre<sup>-1</sup>

$$\therefore K_{\text{sp}} \text{ of AgCl} = [\text{Ag}^+][\text{Cl}^-]$$

$$1.6 \times 10^{-10} = x(x+y) \quad \dots(i)$$

$$\text{Similarly, } K_{\text{sp}} \text{ of CuCl} = [\text{Cu}^+][\text{Cl}^-]$$

$$1.6 \times 10^{-6} = y(x+y) \quad \dots(ii)$$

On solving, (i) and (ii)

$$[\text{Ag}^+] = 1.6 \times 10^{-7} \therefore x = 7$$



## Section-B JEE Main/ AIEEE

1. (a) **NOTE** : A buffer is a solution of weak acid and its salt with strong base and vice versa.  
HCl is strong acid and NaCl is its salt with strong base. pH is less than 7 due to HCl.
2. (a)  $(\text{HSO}_4)^-$  can accept and donate a proton  
 $(\text{HSO}_4)^- + \text{H}^+ \rightarrow \text{H}_2\text{SO}_4$  (acting as base)  
 $(\text{HSO}_4)^- - \text{H}^+ \rightarrow \text{SO}_4^{2-}$ . (acting as acid)
3. (a)  $\text{Mg}(\text{OH})_2 \rightarrow [\text{Mg}^{2+}] + 2[\text{OH}^-]$   
 $\begin{matrix} x & & 2x \\ K_{sp} = [\text{Mg}][\text{OH}]^2 = [x][2x]^2 = x \cdot 4x^2 = 4x^3. \end{matrix}$
4. (a) In this reaction the ratio of number of moles of reactants to products is same i.e. 2 : 2, hence change in volume will not alter the number of moles.
5. (c)  $K_p = K_c(\text{RT})^{\Delta n}$ ;  
 $\Delta n = 1 - \left(1 + \frac{1}{2}\right) = 1 - \frac{3}{2} = -\frac{1}{2} \therefore \frac{K_p}{K_c} = (\text{RT})^{-1/2}$
6. (b) pH of an acidic solution should be less than 7. The reason is that from  $\text{H}_2\text{O}$ ,  $[\text{H}^+] = 10^{-7}\text{M}$  which cannot be neglected in comparison to  $10^{-8}\text{M}$ . The pH can be calculated as.  
 from acid,  $[\text{H}^+] = 10^{-8}\text{M}$ .  
 from  $\text{H}_2\text{O}$ ,  $[\text{H}^+] = 10^{-7}\text{M}$   
 $\therefore$  Total  $[\text{H}^+] = 10^{-8} + 10^{-7} = 10^{-8}(1 + 10) = 11 \times 10^{-8}$   
 $\therefore \text{pH} = -\log [\text{H}^+] = -\log 11 \times 10^{-8} = -[\log 11 + 8 \log 10]$   
 $= -[1.0414 - 8] = 6.9586$
7. (d)  $\text{AB}_2 \rightleftharpoons \text{A}^{+2} + 2\text{B}^-$   
 $[\text{A}] = 1.0 \times 10^{-5}$ ,  $[\text{B}] = [2.0 \times 10^{-5}]$ ,  
 $K_{sp} = [\text{B}]^2 [\text{A}] = [2 \times 10^{-5}]^2 [1.0 \times 10^{-5}] = 4 \times 10^{-15}$
8. (b)  $K_c = \frac{[\text{NO}_2]^2}{[\text{N}_2\text{O}_4]} = \frac{[1.2 \times 10^{-2}]^2}{[4.8 \times 10^{-2}]} = 3 \times 10^{-3} \text{ mol/L}$
9. (b) Due to exothermicity of reaction low or optimum temperature will be required. Since 3 moles are changing to 2 moles.  
 $\therefore$  High pressure will be required.
10. (d) The rain water after thunderstorm contains dissolved acid and therefore the pH is less than rain water without thunderstorm.
11. (d) **NOTE** : Conjugate acid-base differ by  $\text{H}^+$   
 $\text{H}_2\text{PO}_4^- \xrightarrow{-\text{H}^+} \text{HPO}_4^{2-}$   
 Acid conjugate base
12. (d) For  $\text{P}_4(\text{s}) + 5\text{O}_2(\text{g}) \rightleftharpoons \text{P}_4\text{O}_{10}(\text{s})$   
 $K_c = \frac{1}{(\text{O}_2)^5}$ . The solids have concentration unity
13. (c)  $K_p = K_c(\text{RT})^{\Delta n}$ ; Here  $\Delta n = 1 - 2 = -1$   
 $\therefore \frac{K_p}{K_c} = \frac{1}{\text{RT}}$
14. (b)  $K_c = \frac{[\text{NO}]^2}{[\text{N}_2][\text{O}_2]} = 4 \times 10^{-4}$   
 $K'_c = \frac{[\text{N}_2]^{1/2}[\text{O}_2]^{1/2}}{[\text{NO}]} = \frac{1}{\sqrt{K_c}} = \frac{1}{\sqrt{4 \times 10^{-4}}} = 50$
15. (d)  $\text{MX}_4 \rightleftharpoons \text{M}^{4+} + 4\text{X}^-$   
 $K_{sp} = [\text{s}] [4\text{s}]^4 = 256 \text{s}^5 \therefore \text{s} = \left(\frac{K_{sp}}{256}\right)^{1/5}$
16. (b)  $\text{Na}_2\text{SO}_4 \rightleftharpoons 2\text{Na}^+ + \text{SO}_4^{2-}$   
 $\begin{matrix} 1-\alpha & & 2\alpha & & \alpha \end{matrix}$   
 Vant. Hoff's factor  $i = \frac{1 - \alpha + 2\alpha + \alpha}{1} = 1 + 2\alpha$
17. (c)  $\text{MX}_2 \rightleftharpoons \text{M}^{++} + 2\text{X}^-$   
 Where  $s$  is the solubility of  $\text{MX}_2$   
 then  $K_{sp} = 4\text{s}^3$ ;  $\text{s} \times (2\text{s})^2 = 4 \times 10^{-12} = 4\text{s}^3$ ;  $\text{s} = 1 \times 10^{-4}$   
 $\therefore [\text{M}^{++}] = \text{s} = 1[\text{M}^{++}] = 10 \times 10^{-4}$
18. (a) The reaction given is an exothermic reaction thus accordingly to Lechatalier's principle lowering of temperature, addition of  $\text{F}_2$  and or  $\text{Cl}_2$  favour the forward direction and hence the production of  $\text{ClF}_3$ .
19. (d) For the reaction:  $2\text{NO}_2(\text{g}) \rightleftharpoons 2\text{NO}(\text{g}) + \text{O}_2(\text{g})$   
 Given  $K_c = 1.8 \times 10^{-6}$  at  $184^\circ\text{C}$   
 $R = 0.0831 \text{ kJ/mol.k}$   
 $K_p = 1.8 \times 10^{-6} \times 0.0831 \times 457 = 6.836 \times 10^{-6}$   
 $[\because 184^\circ\text{C} = (273 + 184) = 457 \text{ k}, \Delta n = (2 + 1, -1) = 1]$   
 Hence it is clear that  $K_p > K_c$
20. (a)  $\text{pH} = -\log [\text{H}^+] = \log \frac{1}{[\text{H}^+]}$ ;  $5.4 = \log \frac{1}{[\text{H}^+]}$   
 On solving,  $[\text{H}^+] = 3.98 \times 10^{-6}$
21. (a) Conjugate acid-base pair differ by only one proton.  
 $\text{OH}^- \longrightarrow \text{H}^+ + \text{O}^{2-}$  Conjugate base of  $\text{OH}^-$  is  $\text{O}^{2-}$
22. (a)  $\text{NH}_4\text{HS}(\text{s}) \rightleftharpoons \text{NH}_3(\text{g}) + \text{H}_2\text{S}(\text{g})$   
 $\begin{matrix} \text{start} & & 0 & & 0 \\ \text{At equip.} & & 0.5 + x & & x \end{matrix}$

Then  $0.5 + x + x = 2x + 0.5 = 0.84$  (given)

$$\Rightarrow x = 0.17 \text{ atm.}$$

$$p_{\text{NH}_3} = 0.5 + 0.17 = 0.67 \text{ atm}; \quad p_{\text{H}_2\text{S}} = 0.17 \text{ atm}$$

$$K = p_{\text{NH}_3} \times p_{\text{H}_2\text{S}} = 0.67 \times 0.17 \text{ atm}^2 = 0.1139 = 0.11$$

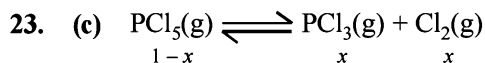

Total moles after dissociation  $1 - x + x + x = 1 + x$

$$p_{\text{PCl}_3} = \text{mole fraction of PCl}_3 \times \text{Total pressure}$$

$$= \left( \frac{x}{1+x} \right) P$$

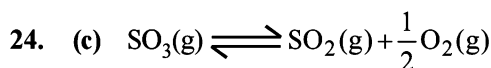

$$K_c = \frac{[\text{SO}_2][\text{O}_2]^{1/2}}{[\text{SO}_3]} = 4.9 \times 10^{-2};$$

On taking the square of the above reaction

$$\frac{[\text{SO}_2]^2[\text{O}_2]}{[\text{SO}_3]^2} = 24.01 \times 10^{-4}$$

now  $K'_c$  for  $2\text{SO}_2(\text{g}) + \text{O}_2(\text{g}) \rightleftharpoons 2\text{SO}_3$

$$= \frac{[\text{SO}_3]^2}{[\text{SO}_2]^2[\text{O}_2]} = \frac{1}{24.01 \times 10^{-4}} = 416$$

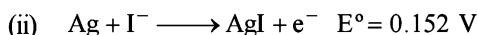
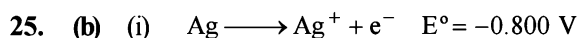

From (i) and (ii) we have,

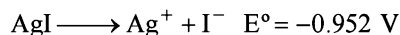

$$E_{\text{cell}}^\circ = \frac{0.059}{n} \log K$$

$$\therefore -0.952 = \frac{0.059}{1} \log [\text{Ag}^+][\text{I}^-] \quad [\because k = [\text{Ag}^+][\text{I}^-]]$$

$$\text{or } -\frac{0.952}{0.059} = \log K_{\text{sp}} \quad \text{or } -16.13 = \log K_{\text{sp}}$$



$$\therefore K_1 = 1.0 \times 10^{-5} = \frac{[\text{H}^+][\text{HA}^-]}{[\text{H}_2\text{A}]} \quad (\text{Given})$$

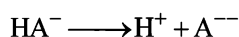

$$\therefore K_2 = 5.0 \times 10^{-10} = \frac{[\text{H}^+][\text{A}^{2-}]}{[\text{HA}^-]} \quad (\text{Given})$$

$$K = \frac{[\text{H}^+]^2[\text{A}^{2-}]}{[\text{H}_2\text{A}]} = K_1 \times K_2$$

$$= (1.0 \times 10^{-5}) \times (5 \times 10^{-10}) = 5 \times 10^{-15}$$

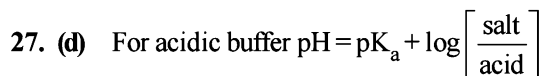

$$\text{or } \text{pH} = \text{p}K_a + \log \left[ \frac{[\text{A}^-]}{[\text{HA}]} \right]$$

Given  $\text{p}K_a = 4.5$  and acid is 50% ionised.

$$[\text{HA}] = [\text{A}^-] \quad (\text{when acid is 50\% ionised})$$

$$\therefore \text{pH} = \text{p}K_a + \log 1 \quad \therefore \text{pH} = \text{p}K_a = 4.5$$

$$\text{pOH} = 14 - \text{pH} = 14 - 4.5 = 9.5$$

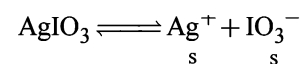
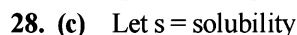

$$K_{\text{sp}} = [\text{Ag}^+][\text{IO}_3^-] = s \times s = s^2$$

$$\text{Given } K_{\text{sp}} = 1 \times 10^{-8}$$

$$\therefore s = \sqrt{K_{\text{sp}}} = \sqrt{1 \times 10^{-8}}$$

$$= 1.0 \times 10^{-4} \text{ mol/lit} = 1.0 \times 10^{-4} \times 283 \text{ g/lit}$$

$$(\because \text{Molecular mass of Ag IO}_3 = 283)$$

$$= \frac{1.0 \times 10^{-4} \times 283 \times 100}{1000} \text{ gm/100ml}$$

$$= 2.83 \times 10^{-3} \text{ gm/100 ml}$$

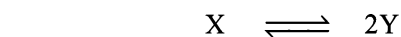
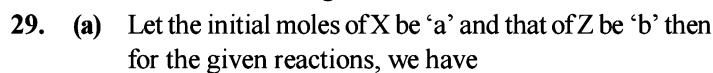

Initial	a moles	0
At equi.	$a(1-\alpha)$	$2a\alpha$
(moles)		

$$\text{Total no. of moles} = a(1-\alpha) + 2a\alpha$$

$$= a - a\alpha + 2a\alpha = a(1+\alpha)$$

$$\text{Now, } K_{\text{P}_1} = \frac{(n_y)^2}{n_x} \times \left( \frac{P_{\text{T}_1}}{\sum n} \right)^{\Delta n}$$

$$\text{or, } K_{\text{P}_1} = \frac{(2a\alpha)^2 \cdot P_{\text{T}_1}}{[a(1-\alpha)][a(1+\alpha)]}$$

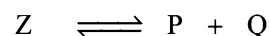

Initial	b moles	0	0
At equi.	$b(1-\alpha)$	$b\alpha$	$b\alpha$
(moles)			

$$\begin{aligned} \text{Total no. of moles} &= b(1-\alpha) + b\alpha + b\alpha \\ &= b - b\alpha + b\alpha + b\alpha = b(1+\alpha) \end{aligned}$$

$$\text{Now } K_{P_2} = \frac{n_Q \times n_P}{n_z} \times \left[ \frac{P_{T_2}}{\sum n} \right]^{\Delta n}$$

$$\text{or } K_{P_2} = \frac{(b\alpha)(b\alpha).P_{T_2}}{[b(1-\alpha)][b(1+\alpha)]}$$

$$\text{or } \frac{K_{P_1}}{K_{P_2}} = \frac{4\alpha^2.P_{T_1}}{(1-\alpha^2).P_{T_2}} \times \frac{(1-\alpha)^2}{P_{T_2}.\alpha^2} = \frac{4P_{T_1}}{P_{T_2}}$$

$$\text{or } \frac{P_{T_1}}{P_{T_2}} = \frac{1}{9} \left[ \because \frac{K_{P_1}}{K_{P_2}} = \frac{1}{9} \text{ given} \right]$$

$$\text{or } \frac{P_{T_1}}{P_{T_2}} = \frac{1}{36} \text{ or } 1 : 36$$

i.e., (a) is the correct answer.

30. (c) Reaction (c) can be obtained by adding reactions (a) and (b) therefore  $K_3 = K_1 \cdot K_2$

Hence (c) is the correct answer.

31. (c) The correct order of acidic strength of the given species

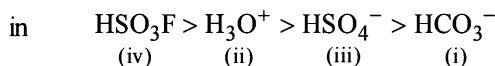

or (i) < (iii) < (ii) < (iv)

It corresponds to choice (c) which is correct answer.

32. (c) In aqueous solution BA(salt) hydrolyses to give

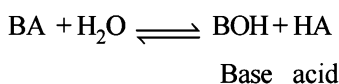

Now pH is given by

$$\text{pH} = \frac{1}{2} \text{p}K_w + \frac{1}{2} \text{p}K_a - \frac{1}{2} \text{p}K_b$$

Substituting given values, we get

$$\text{pH} = \frac{1}{2}(14 + 4.80 - 4.78) = 7.01$$

33. (a)  $\text{Na}_2\text{CO}_3 \longrightarrow 2\text{Na}^+ + \text{CO}_3^{2-}$   
 $1 \times 10^{-4} \text{M} \qquad 1 \times 10^{-4} \text{M} \qquad 1 \times 10^{-4} \text{M}$

$$K_{\text{SP}}(\text{BaCO}_3) = [\text{Ba}^{2+}][\text{CO}_3^{2-}]$$

$$[\text{Ba}^{2+}] = \frac{5.1 \times 10^{-9}}{1 \times 10^{-4}} = 5.1 \times 10^{-5} \text{M}$$

34. (a) (i)  $\text{H}_3\text{PO}_4 + \text{H}_2\text{O} \longrightarrow \text{H}_3\text{O}^+ + \text{H}_2\text{PO}_4^-$   
 $\text{acid}_1 \qquad \text{base}_2 \qquad \text{acid}_2 \qquad \text{base}_1$

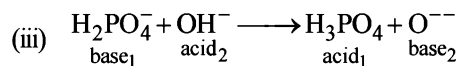
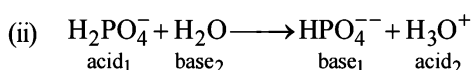

Hence only in (ii) reaction  $\text{H}_2\text{PO}_4^-$  is acting as an acid.

35. (c)  $\text{H}_2\text{CO}_3(aq) + \text{H}_2\text{O}(l) \rightleftharpoons \text{HCO}_3^-(aq) + \text{H}_3\text{O}^+(aq)$   
 $0.034-x \qquad \qquad \qquad x \qquad \qquad \qquad x$

$$K_1 = \frac{[\text{HCO}_3^-][\text{H}_3\text{O}^+]}{[\text{H}_2\text{CO}_3]} = \frac{x \times x}{0.034-x}$$

$$\Rightarrow 4.2 \times 10^{-7} \approx \frac{x^2}{0.034} \Rightarrow x = 1.195 \times 10^{-4}$$

As  $\text{H}_2\text{CO}_3$  is a weak acid so the concentration of  $\text{H}_2\text{CO}_3$  will remain 0.034 as  $0.034 \gg x$ .

$$x = [\text{H}^+] = [\text{HCO}_3^-] = 1.195 \times 10^{-4}$$

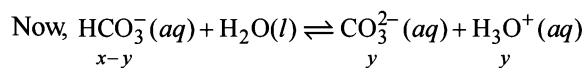

As  $\text{HCO}_3^-$  is again a weak acid (weaker than  $\text{H}_2\text{CO}_3$ ) with  $x \gg y$ .

$$K_2 = \frac{[\text{CO}_3^{2-}][\text{H}_3\text{O}^+]}{[\text{HCO}_3^-]} = \frac{y \times (x+y)}{(x-y)}$$

**Note :**  $[\text{H}_3\text{O}^+] = \text{H}^+$  from first step (x) and from second step (y) = (x + y)

[As  $x \gg y$  so  $x + y \approx x$  and  $x - y \approx x$ ]

$$\text{So, } K_2 \approx \frac{y \times x}{x} = y$$

$$\Rightarrow K_2 = 4.8 \times 10^{-11} = y = [\text{CO}_3^{2-}]$$

So the concentration of  $[\text{H}^+] \approx [\text{HCO}_3^-]$  = concentrations obtained from the first step. As the dissociation will be very low in second step so there will be no change in these concentrations.

Thus the final concentrations are

$$[\text{H}^+] = [\text{HCO}_3^-] = 1.195 \times 10^{-4} \text{ \& } [\text{CO}_3^{2-}] = 4.8 \times 10^{-11}$$

36. (b)  $\text{AgBr} \rightleftharpoons \text{Ag}^+ + \text{Br}^-$

$$K_{\text{sp}} = [\text{Ag}^+][\text{Br}^-]$$

For precipitation to occur

Ionic product > Solubility product

$$[\text{Br}^-] = \frac{K_{\text{sp}}}{[\text{Ag}^+]} = \frac{5 \times 10^{-13}}{0.05} = 10^{-11}$$

i.e., precipitation just starts when  $10^{-11}$  moles of KBr is added to 1 l AgNO<sub>3</sub> solution

$\therefore$  Number of moles of Br<sup>-</sup> needed from KBr =  $10^{-11}$

$\therefore$  Mass of KBr =  $10^{-11} \times 120 = 1.2 \times 10^{-9}$  g

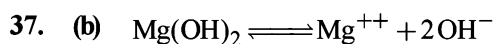

$$K_{sp} = [\text{Mg}^{++}][\text{OH}^-]^2$$

$$1.0 \times 10^{-11} = 10^{-3} \times [\text{OH}^-]^2$$

$$[\text{OH}^-] = \sqrt{\frac{10^{-11}}{10^{-3}}} = 10^{-4}$$

$$\therefore \text{pOH} = 4 \quad \therefore \text{pH} + \text{pOH} = 14 \quad \therefore \text{pH} = 10$$

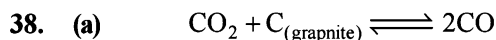

$$P_{\text{initial}} \quad 0.5 \text{ atm} \quad \quad \quad 0$$

$$P_{\text{final}} \quad (0.5 - x) \text{ atm} \quad \quad \quad 2x \text{ atm}$$

$$\text{Total P at equilibrium} = 0.5 - x + 2x = 0.5 + x \text{ atm}$$

$$0.8 = 0.5 + x$$

$$\therefore x = 0.8 - 0.5 = 0.3 \text{ atm}$$

$$\text{Now } K_p = \frac{(P_{\text{CO}})^2}{P_{\text{CO}_2}} = \frac{(2 \times 0.3)^2}{(0.5 - 0.3)} = \frac{(0.6)^2}{(0.2)}$$

$$= 1.8 \text{ atm}$$



Hence for the reaction

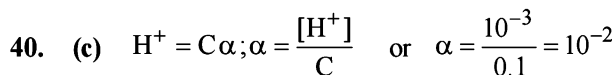
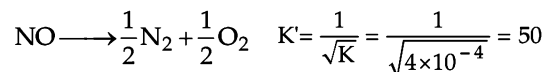

$$K_a = C\alpha^2 = 0.1 \times 10^{-2} \times 10^{-2} = 10^{-5}$$

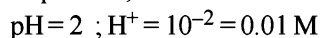
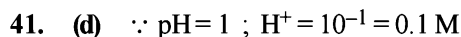

$$\therefore M_1 = 0.1 \quad V_1 = 1; M_2 = 0.01 \quad V_2 = ?$$

From

$$M_1 V_1 = M_2 V_2; 0.1 \times 1 = 0.01 \times V_2$$

$$V_2 = 10 \text{ litre}$$

$$\therefore \text{volume of water added} = 10 - 1 = 9 \text{ litre.}$$

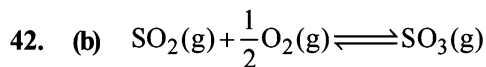

$$K_P = K_C (RT)^x$$

where  $x = \Delta n_g =$  number of gaseous moles in product

– number of gaseous moles in reactant

$$= 1 - \left(1 + \frac{1}{2}\right) = 1 - \frac{3}{2} = -\frac{1}{2}$$

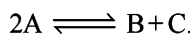

$$R = 8.314 \text{ J/K/mol.}$$

$$e = 2.718$$

$$[\text{A}] = \frac{1}{2}, [\text{B}] = 2, [\text{C}] = \frac{1}{2}; Q = \frac{[\text{B}][\text{C}]}{[\text{A}]^2} = \frac{2 \times 1/2}{\left(\frac{1}{2}\right)^2} = 4$$

$$\Delta G^\circ = -2.303 RT \log K_c.$$

$$2494.2 \text{ J} = -2.303 \times (8.314 \text{ J/K/mol}) \times (300 \text{ K}) \log K_c$$

$$\Rightarrow \log K_c = -\frac{2494.2 \text{ J}}{2.303 \times 8.314 \text{ J/K/mol} \times 300 \text{ K}}$$

$$\Rightarrow \log K_c = -0.4341; K_c = 0.37; Q > K_c.$$

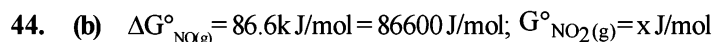

$$T = 298, K_p = 1.6 \times 10^{12}$$

$$\Delta G^\circ = -RT \ln K_p$$

Given equation,

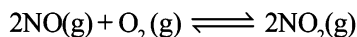

$$\therefore 2\Delta G^\circ_{\text{NO}_2} - 2\Delta G^\circ_{\text{NO}} = -R(298) \ln(1.6 \times 10^{12})$$

$$2\Delta G^\circ_{\text{NO}_2} - 2 \times 86600 = -R(298) \ln(1.6 \times 10^{12})$$

$$2\Delta G^\circ_{\text{NO}_2} = 2 \times 86600 - R(298) \ln(1.6 \times 10^{12})$$

$$\Delta G^\circ_{\text{NO}_2} = \frac{1}{2} [2 \times 86600 - R(298) \ln(1.6 \times 10^{12})]$$

$$= 0.5 [2 \times 86600 - R(298) \ln(1.6 \times 10^{12})]$$

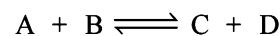
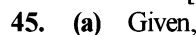

$$\text{No. of moles initially} \quad 1 \quad 1 \quad 1 \quad 1$$

$$\text{At equilibrium} \quad 1-a \quad 1-a \quad 1+a \quad 1+a$$

$$\therefore K_c = \left(\frac{1+a}{1-a}\right)^2 = 100$$

$$\therefore \frac{1+a}{1-a} = 10$$

On solving

$$a = 0.81$$

$$[\text{D}]_{\text{At eq}} = 1 + a = 1 + 0.81 = 1.81$$

**Section-A : JEE Advanced/ IIT-JEE**

- A** 1. Anhydrous HCl 2. occlusion 3. of solvated electrons  
4. Hydrogen, anode 5. higher effective nuclear charge
- B** 1. F 2. T 3. F
- C** 1. (b) 2. (c) 3. (a) 4. (d) 5. (c) 6. (b) 7. (b)  
8. (d) 9. (d) 10. (a) 11. (b) 12. (b) 13. (b) 14. (b)  
15. (a) 16. (a)
- D** 1. (b, d) 2. (a, c) 3. (a, b) 4. (a) 5. (a) 6. (a, b) 7. (b, c, d)
- E** 6. 4.48 volumes 8. 1.344  
10. Ba, Ba<sub>3</sub>N<sub>2</sub>, Ba(OH)<sub>2</sub>, BaCO<sub>3</sub> 11. SrSO<sub>4</sub> > CaSO<sub>4</sub> > MgSO<sub>4</sub> > BeSO<sub>4</sub>
- H** 1. (a) 2. (b)

**Section-B : JEE Main/ AIEEE**

1. (a) 2. (a) 3. (d) 4. (a) 5. (a) 6. (a) 7. (b)  
8. (a) 9. (c) 10. (c) 11. (a) 12. (d) 13. (d) 14. (c)  
15. (d) 16. (d) 17. (d) 18. (b) 19. (c) 20. (a) 21. (b)  
22. (b)

**Section-A JEE Advanced/ IIT-JEE****A. Fill in the Blanks**

1. **Anhydrous HCl**  
∴ All the water of crystallisation cannot be removed by heating hydrated MgCl<sub>2</sub>.
2. **occlusion.**
3. **of solvated electrons.**
4. **Hydrogen, anode.**

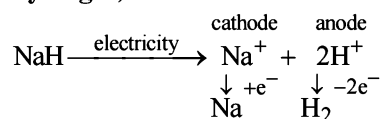

5. **higher effective nuclear charge.**

**B. True/False**

1. **False** : Although 4 molecules of water of crystallisation are removed by heating, the remaining two react with MgCl<sub>2</sub> as per the equation given below :  
 $\text{MgCl}_2 + 2\text{H}_2\text{O} \rightarrow \text{MgO} + 2\text{HCl} + \text{H}_2\text{O}$   
**NOTE** : In order to avoid this to happen, MgCl<sub>2</sub>·2H<sub>2</sub>O is dehydrated in presence of HCl gas, which checks, (being in excess) the hydrolysis of MgCl<sub>2</sub> by its own water of crystallisation.

2. **True** : The metallic bonding decreases with increase in atomic size and thus the tendency to show metallic bonding among alkali metals decreases from Li to Cs and thus close packing of atoms in crystal lattice decreases from Li to Cs resulting in an increase in softness.
3. **False** : Sodium when burnt in excess of oxygen gives monoxide and sodium peroxide (Na<sub>2</sub>O<sub>2</sub>) and not sodium oxide.  
 $4\text{Na} + \text{O}_2 \rightarrow 2\text{Na}_2\text{O}$ ;  $2\text{Na} + \text{O}_2 \rightarrow \text{Na}_2\text{O}_2$

**C. MCQs with One Correct Answer**

1. (b)  $\text{CaO} + \text{H}_2\text{O} \xrightarrow{\text{Hissing sound}} \text{Ca(OH)}_2 + \text{Heat}$   
 $\text{CaO} + \text{CO}_2 \longrightarrow \text{CaCO}_3$
2. (c)  $\text{BaO}_2 \cdot 8\text{H}_2\text{O} + \text{H}_2\text{SO}_4 \longrightarrow \text{BaSO}_4 + \text{H}_2\text{O}_2 + 8\text{H}_2\text{O}$
3. (a) Ca is obtained by electrolysis of molten mixture of CaCl<sub>2</sub> mixed with CaF<sub>2</sub>.
4. (d) The free ammoniated electrons make the solution of Na in liquid NH<sub>3</sub> a very powerful reducing agent.

**NOTE** : The ammonical solution of an alkali metal is rather favoured as a reducing agent than its aqueous solution because in aqueous solution the alkali metal being highly electropositive evolves hydrogen from water (thus H<sub>2</sub>O acts as an oxidising agent) while its solution in ammonia is quite stable, provided no catalyst (transition metal) is present.

5. (c) Heavy water is  $D_2O$ , deuterium oxide.
6. (b)  $Na^+$  ion has larger size than  $Mg^{2+}$  ion and hence hydration energy of  $Mg^{2+}$  is larger than that of  $Na^+$ .
7. (b)  $Na_2O_2 + H_2SO_4$  (20% ice cold)  $\longrightarrow Na_2SO_4 + H_2O_2$
8. (d) Glauber's salt is  $Na_2SO_4 \cdot 10H_2O$ .
9. (d) **NOTE** : The more electropositive metal will not be reduced by hydrogen.  
Among given choices only Al is more electropositive than hydrogen.  
 $\therefore$  It will not be reduced by hydrogen.
10. (a) **NOTE** : Acidic and basic salts cannot exist together. Since  $NaHCO_3$  is an acid salt of  $H_2CO_3$ , it reacts with  $NaOH$  to form  $Na_2CO_3$  and  $H_2O$ .  
 $NaHCO_3 + NaOH \longrightarrow Na_2CO_3 + H_2O$
11. (b) Oscillation of loose electrons.
12. (b) Volume strength = Normality  $\times 5.6 = 1.5 \times 5.6 = 8.4$  L
13. (b) The increasing thermal stability is  
 $BeCO_3 < MgCO_3 < CaCO_3 < K_2CO_3$   
(IV) (II) (III) (I)  
**NOTE** : Increasing size of cation decreases its polarization ability towards carbonate, making the compound more stable.
14. (b) In going from top to bottom in a group, the first ionization potential decreases, thus  
 $Be > Mg > Ca$

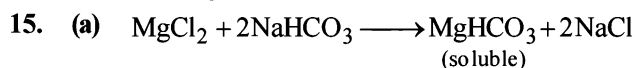

16. (a)  $KIO_4 + H_2O_2 \longrightarrow KIO_3 + H_2O + O_2$   
Thus  $H_2O_2$  is acting as a reducing agent  
 $2NH_2OH + H_2O_2 \longrightarrow N_2 + 4H_2O$   
Here  $H_2O_2$  is acting as an oxidising agent

#### D. MCQs with One or More Than One Correct

1. (b,d)  $Na_2Al_2Si_2O_8 \cdot xH_2O + Ca^{2+} \longrightarrow CaAl_2Si_2O_8 \cdot xH_2O + 2Na^+$   
 $Na_2Al_2Si_2O_8 \cdot xH_2O + Mg^{2+} \longrightarrow MgAl_2Si_2O_8 \cdot xH_2O + 2Na^+$
2. (a,c) Only  $H_2O_2$  (hydrogen peroxide) and  $BaO_2$  (Barium peroxide) contain peroxide ions. So (a) and (c) are the correct choices.
3. (a,b) Blue colour is due to the presence of solvated (ammoniated) electrons, while electrical conductance is due to the presence of ions.

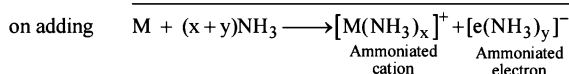
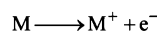

**NOTE** : Sodium in liquid ammonia forms  $NaNH_2$  only in presence of a catalyst like Pt black, iron oxide etc.

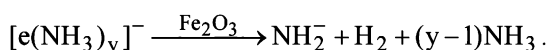

4. (a)  $CO_2 + H_2O \rightleftharpoons H_2CO_3$   
 $\rightleftharpoons H^+ + HCO_3^- \rightleftharpoons H^+ + CO_3^{2-}$

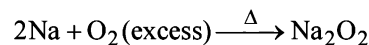
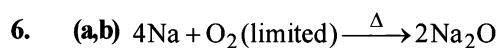

7. (b,c,d) Temporary hardness is due to bicarbonates of calcium and magnesium. Temporary hardness can be removed by Clark's process, which involves the addition of slaked lime,  $Ca(OH)_2$ . Washing soda ( $Na_2CO_3$ ) removes both the temporary and permanent hardness by converting soluble calcium and magnesium compounds into insoluble carbonates.

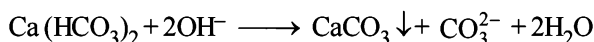
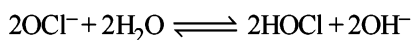
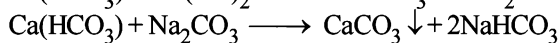
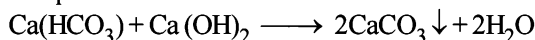

#### E. Subjective Problems

1. (i) Potassium carbonate cannot be manufactured by Solvay process, since, unlike sodium hydrogen carbonate, potassium hydrogen carbonate is rather too soluble in water to be precipitated like  $NaHCO_3$ .
- (ii)  $H_2O_2$  is a better oxidising agent than  $H_2O$  because oxidation number of oxygen in  $H_2O_2$  is  $-1$  and that in water it is  $-2$ . So  $H_2O_2$  easily reduces to  $-2$  oxidation number.
- (iii)  $MgO$  is used for the lining of steel making furnace because it acts as basic flux and facilitates the removal of acidic impurities of Si, P and S from steel through slag formation.
- (iv) The anhydrous magnesium chloride is fused with  $NaCl$  to provide conductivity to the electrolyte and to lower the fusion temperature of anhydrous  $MgCl_2$ .  
**NOTE** :  $NaCl$  prevents hydrolysis of  $MgCl_2$ .
- (v) The oxidation state of oxygen in  $H_2O_2$  (i.e.  $-1$ ) can be changed to  $0$  or  $-2$  i.e. oxygen in  $H_2O_2$  exists in an intermediate oxidation state with respect to  $O_2$  and  $O^{2-}$ . Hence it acts both as an oxidising and reducing agent.
- (vi) **NOTE** : Smaller the size of cation, higher will be hydration tendency because **hydration energy of cation is inversely proportional to size of cation**.  
The size of alkaline earth metal ions are smaller than the size of alkali metal ions. So in crystalline form the salts of alkaline earth metals have more water molecules than those of alkali metals.
- (vii)  $BeCl_2$  is hydrolysed due to high polarising power and presence of vacant p-orbitals in Be-atom.

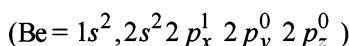

2. Bleaching powder,  $Ca(OCl)_2$ , can be prepared by passing chlorine through  $Ca(OH)_2$  solution.

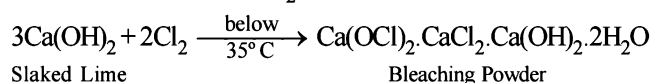

Slaked Lime

Bleaching Powder

(a mixture of  $Ca(OCl)_2$  and basic chloride)



This is the **electrothermal process** to extract phosphorus from phosphorite or bone ash [ $\text{Ca}_3(\text{PO}_4)_2$ ].

(ii) Ferricyanide is oxidised to ferrocyanide on treatment with alkali

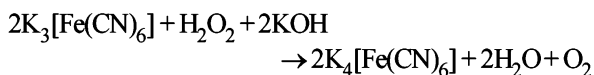

(iii)  $\text{NaCl} + \text{NH}_4\text{OH} + \text{CO}_2 \rightarrow \text{NH}_4\text{Cl} + \text{NaHCO}_3$

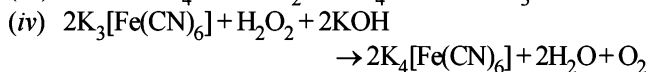

(v)  $\text{CaCO}_3 + \text{CO}_2 + \text{H}_2\text{O} \rightarrow \text{Ca}(\text{HCO}_3)_2$   
Calcium bicarbonate

**NOTE :** Suspension of lime stone is  $\text{CaCO}_3$ .

4. In sea water Mg exists as  $\text{MgCl}_2$ .

On treating sea water with slaked lime  $\text{Mg}(\text{OH})_2$  is obtained.

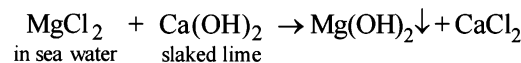

On reacting  $\text{Mg}(\text{OH})_2$  with HCl,  $\text{MgCl}_2$  is obtained.

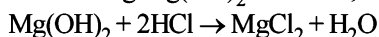

From  $\text{MgCl}_2$ , Mg is obtained by reduction of  $\text{MgCl}_2$  with  $\text{CaC}_2$ .

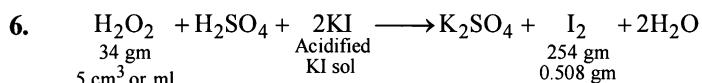
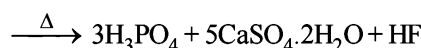
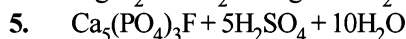
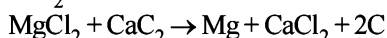

i.e. 254 gm of  $\text{I}_2$  is released by 34 gm  $\text{H}_2\text{O}_2$

$\therefore$  0.508 gm of  $\text{I}_2$  will be released by

$$= \frac{34}{254} \times 0.508 = 0.068 \text{ gm}$$

5 ml of  $\text{H}_2\text{O}_2$  sol. contains 0.068 gm of  $\text{H}_2\text{O}_2$ .

$\therefore$  1 ml of  $\text{H}_2\text{O}_2$  sol contains  $\frac{0.068}{5}$  gm  $\text{H}_2\text{O}_2$

**NOTE :** The strength of  $\text{H}_2\text{O}_2$  is generally calculated in terms of **volume strength**. According to which 10 volume of  $\text{H}_2\text{O}_2$  means that 1 ml of  $\text{H}_2\text{O}_2$  sol gives 10 ml of  $\text{O}_2$  at STP.

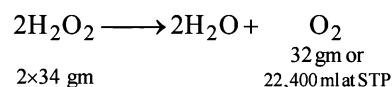

i.e., 68 gm of  $\text{H}_2\text{O}_2$  gives 22,400 ml of  $\text{O}_2$  at STP  
or 1 ml of  $\text{H}_2\text{O}_2$  sol

$$\text{or } \frac{0.068}{5} \text{ gm of } \text{H}_2\text{O}_2 \text{ gives } \frac{22,400}{68} \times \frac{0.068}{5} = 4.48 \text{ ml}$$

or 1 ml of  $\text{H}_2\text{O}_2$  sol gives 4.48 ml of  $\text{O}_2$  i.e. strength of  $\text{H}_2\text{O}_2$  sol is **4.48 volumes**

7. LiF has more ionic character while LiI has more covalent character. The latter is due to the greater polarizability of larger iodide ion than the fluoride ion.

8. Meq. of  $\text{H}_2\text{O}_2 = \text{Meq. of } \text{Na}_2\text{S}_2\text{O}_3$

$$\frac{w}{17} \times 1000 = 20 \times 0.3 \quad \therefore w = 0.102 \text{ g}$$

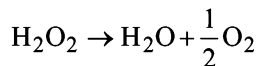

$$\therefore \text{Volume of } \text{O}_2 = \frac{11200 \times 0.102}{34} = 33.6 \text{ mL}$$

$$\therefore \text{Volume strength} = \frac{33.6}{25} = \mathbf{1.344}$$

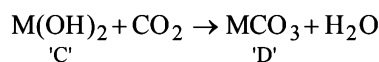
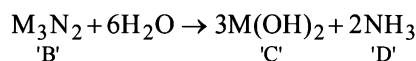
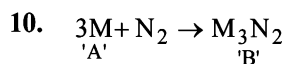
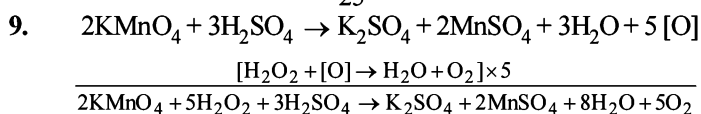

M may be either Ca or Ba.

**NOTE :** It is not magnesium because  $\text{Mg}(\text{OH})_2$  has very low solubility in water.

If we consider Ba as M then A is **Ba**, B is **Ba<sub>3</sub>N<sub>2</sub>**, C is **Ba(OH)<sub>2</sub>**, D is **BaCO<sub>3</sub>**.

11.  $\text{SrSO}_4 > \text{CaSO}_4 > \text{MgSO}_4 > \text{BeSO}_4$  (Based upon size of cation or ionic character)

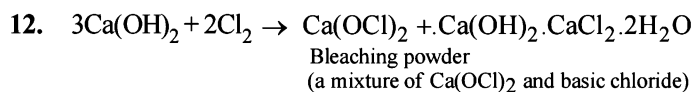

13. When  $\text{H}_2\text{O}_2$  acts as oxidising agent, following reaction takes place:

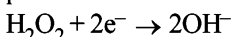

While regarding its action as reducing agent, the following reaction takes place:

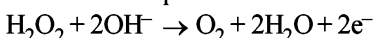

Examples of oxidising character of  $\text{H}_2\text{O}_2$  in alkaline medium

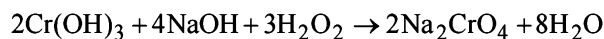

Here  $\text{Cr}^{3+}$  (Cr is a first row transition metal) is oxidised to  $\text{Cr}^{6+}$ .

Example of reducing character of  $\text{H}_2\text{O}_2$  in alkaline medium

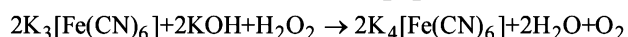

Here  $\text{Fe}^{3+}$  (Fe is a first row transition metal) is reduced to  $\text{Fe}^{2+}$ .

## H. Assertion & Reason Type Questions

- (a) Both S & E are true and E is the correct explanation of S.
- (b) Statement-1 is correct. Statement-2 is also correct but not the correct explanation because blue colour of the solution is due to the solvated electrons.

## Section-B

## JEE Main/ AIEEE

- (a)  $2\text{KO}_2 + 2\text{H}_2\text{O} \rightarrow 2\text{KOH} + \text{H}_2\text{O}_2 + \text{O}_2$ .  
 $\text{KO}_2$  is used as an oxidising agent. It is used as air purifier in space capsules. Submarines and breathing masks as it **produces oxygen and remove carbon dioxide**.
- (a) The alkali metals dissolve in liquid ammonia without evolution of hydrogen. The metal loses electrons and combine with ammonia molecule.  
 $\text{M} \rightarrow \text{M}^+$  (in liquid ammonia) +  $e^-$  (ammoniated)  
 $\text{M} + (x+y)\text{NH}_3 \rightarrow [\text{M}(\text{NH}_3)_x]^+ + e^-(\text{NH}_3)_y$   
Solvated electron  
 It is ammoniated electron which is responsible for colour.
- (d) Sulphate of alkaline earth metal are sparingly soluble or almost not soluble in water whereas  $\text{BeSO}_4$  is soluble in water due to high degree of solvation.  $\text{Be}(\text{OH})_2$  is insoluble in water but soluble in  $\text{NaOH}$ .  
 $\text{BeO} + 2\text{NaOH} \rightarrow \text{Na}_2\text{BeO}_2 + \text{H}_2\text{O}$
- (a) Setting of cement is exothermic process which develops interlocking crystals of hydrated silicates
- (a) Gypsum is  $\text{CaSO}_4 \cdot 2\text{H}_2\text{O}$
- (a) As we move down the group, the lattice energies of carbonates remain approximately the same. However the hydration energies of the metal cation decreases from  $\text{Be}^{++}$  to  $\text{Ba}^{++}$ , hence the solubilities of carbonates of the alkaline earth metal decrease down the group mainly due to decreasing hydration energies of the cations from  $\text{Be}^{++}$  to  $\text{Ba}^{++}$ .
- (b) Permanent hardness of water is due to chlorides and sulphates of calcium and magnesium i.e.  $\text{CaCl}_2$ ,  $\text{CaSO}_4$ ,  $\text{MgCl}_2$  and  $\text{MgSO}_4$ .
- (a)  $\text{Mg}_3\text{N}_2 + 6\text{H}_2\text{O} \rightleftharpoons 3\text{Mg}(\text{OH})_2 + 2\text{NH}_3$
- (c) **TIPS/Formulae :**  
 A diamagnetic substance contains no unpaired electron.  
 $\text{H}_2$  is diamagnetic as it contains all paired electrons  
 $\text{H}_2 = \sigma_b^2$ ,  $\text{H}_2^+ = \sigma_b^1$ ,  $\text{H}_2^- = \sigma_b^2$ ,  
 (diamagnetic) (paramagnetic) (paramagnetic)  
 $\sigma_a^{*1}; \text{He}_2^+ = \sigma_b^2, \sigma_a^{*1}$   
 (paramagnetic) (paramagnetic)
- (c)  $\text{LiCl}$  has partly covalent character. Other halides are ionic in nature. Lattice energy decreases with increase of ionic radius of cation, anion being the same. Larger is the lattice energy, the higher will be m. pt. hence  $\text{NaCl}$  will have highest lattice energy.
- (a) **NOTE :** In one electron species, such as H-atom, the energy of orbital depends only on the principal quantum number, n.  
 Hence answer (d)  
 i.e.  $s < 2s = 2p < 3s = 3p < 3d < 4s = 4p < 4d = 4g$
- (d) Smaller the size of cation higher is its hydration energy and greater is its ionic mobility hence the correct order is  $\text{Li}^+ < \text{Na}^+ < \text{K}^+ < \text{Rb}^+$
- (d) On the industrial scale hydrogen is prepared from water gas according to following reaction sequence

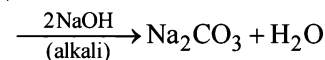
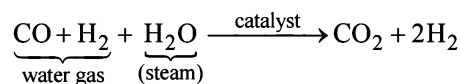

From the above it is clear that CO is first oxidised to  $\text{CO}_2$  which is then absorbed in  $\text{NaOH}$ .

- (c) Calcium carbonate on thermal decomposition gives  $\text{CaO}$  (Basic oxide) and  $\text{CO}_2$  (Acidic oxide)

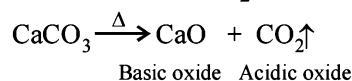

- (d) Very pure hydrogen can be prepared by the action of water on sodium hydride.

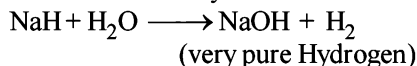

- (d) The reducing agent loses electron during redox reaction i.e. oxidises itself.

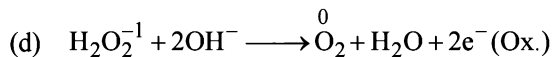
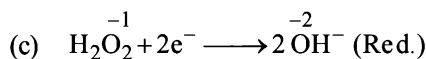
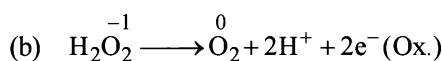
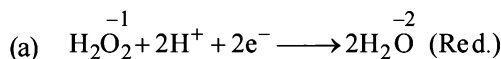

- (d) In alkaline earth metals, ionic size increases down the group. The lattice energy remains constant because sulphate ion is so large, so that small change in cationic size does not make any difference. On moving down the group the degree of hydration of metal ions decreases very much leading to decrease in solubility.

$\therefore \text{BeSO}_4 > \text{MgSO}_4 > \text{CaSO}_4 > \text{SrSO}_4 > \text{BaSO}_4$

- (b) 2 mole of water softner require 1 mole of  $\text{Ca}^{2+}$  ion

So, 1 mole of water softner require  $\frac{1}{2}$  mole of  $\text{Ca}^{2+}$  ion

Thus,  $\frac{1}{2 \times 206} = \frac{1}{412} \text{ mol/g}$  will be maximum uptake

- (c)  $\text{H}_2\text{O}_2$  has oxidizing and reducing properties both.
- (a) There is extensive intermolecular hydrogen bonding in the condensed phase instead of intramolecular H-bonding.
- (b) Alkali metals have the lowest ionization energy in each period on the other hand Sc is a d-block element. Transition metals have smaller atomic radii and higher nuclear charge leading to high ionisation energy.
- (b) On heating with excess of air Li, Na and K forms following oxides

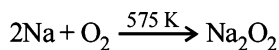
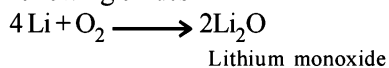

Sodium peroxide

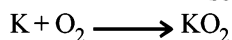

Potassium superoxide





# Organic Chemistry — Some Basic Principles & Techniques

## Section-A : JEE Advanced/ IIT-JEE

- A** 1. tert-butyl carbonium ion 2. propadiene 3. cyclopropane 4.  $sp^3$   
 5. vicinal, adjacent 6. non-superimposable, enantiomers 7.  $sp$   
 8. hyperconjugation 9. butane-1, 4-dioic acid
- B** 1. F 2. F 3. F 4. T
- C** 1. (c) 2. (a) 3. (d) 4. (c) 5. (d) 6. (a) 7. (c) 8. (d) 9. (c) 10. (c)  
 11. (b) 12. (b) 13. (a) 14. (d) 15. (d) 16. (c) 17. (b) 18. (b) 19. (c) 20. (b)  
 21. (a) 22. (b) 23. (c) 24. (c) 25. (d) 26. (d) 27. (b) 28. (b) 29. (d) 30. (c)  
 31. (a) 32. (c) 33. (d) 34. (b) 35. (d) 36. (d) 37. (d) 38. (c) 39. (b) 40. (c)  
 41. (b) 42. (a) 43. (a) 44. (c) 45. (c) 46. (a) 47. (b) 48. (b) 49. (a) 50. (a)  
 51. (b) 52. (d) 53. (b) 54. (d) 55. (c) 56. (b)
- D** 1. (a,b,c) 2. (a, c) 3. (b, d) 4. (a, d) 5. (c,d) 6. (a) 7. (a, c) 8. (d) 9. (a, c, d) 10. (b, c, d)  
 11. (b,c,d) 12. (a,d) 13. (a,d) 14. (b, d) 15. (b,c) 16. (b,c) 17. (a,b,c) 18. (a)
- E** 1. (i)  $C_2H_5COCH_3 < CH_3COCH_3 < CH_3CHO < HCHO$  (ii) isobutane < n-butane < n-butyl chloride < n-butanol  
 (iii) chlorobenzene < benzene < toluene < methoxybenzene (iv) IV < II < III < V < I  
 (v)  $CH_3F < CH_3Cl < CH_3Br < CH_3I$   
 2. (i) Pent-2-en-1-oic acid or 2-Pentenoic acid (ii) 5, 6-diethyl-3-methyl-4-decene  
 (iii) 3-(N, N dimethylamino)-3-methylpentane  
 5.  $CH_3-\underset{\text{Cl}}{\text{CH}}-\underset{\text{Cl}}{\text{CH}}=\text{CH}-CH_3$  9. enantiomers – I & III; diastereomers – I & II and II & III.
10. Anhydrous  $AlCl_3$  14. (i)  $\mu_{\text{(gauche)}} = 5.55 D$
- F** 1. (A) - (q), (B) - (p, s), (C) - (r, s), (D) - (q) 2. (A) - (p, s); (B) - (q); (C) - (q, r, s); (D) - (q, r)  
 3. (A) - (p,q,t); (B) - (p,s,t); (C) - (r,s); (D) - (p) 4. (A) - (r,s,t); (B) - (p,s); (C) - (r,s); (D) - (q,r)
- H** 1. (d) 2. (a) 3. (c)
- I** 1. 7 2. 5 3. 8 4. 6 5. 3 6. 2

## Section-B : JEE Main/ AIEEE

1. (b) 2. (c) 3. (c) 4. (d) 5. (c) 6. (c) 7. (b) 8. (d) 9. (d) 10. (b)  
 11. (d) 12. (a) 13. (a) 14. (d) 15. (a) 16. (a) 17. (b) 18. (c) 19. (a) 20. (d)  
 21. (d) 22. (c) 23. (d) 24. (a) 25. (d) 26. (a) 27. (b) 28. (c) 29. (b) 30. (a)  
 31. (a) 32. (b) 33. (a) 34. (b) 35. (b) 36. (b) 37. (a) 38. (a) 39. (b) 40. (b)  
 41. (b) 42. (d) 43. (c) 44. (c) 45. (c) 46. (d) 47. (b) 48. (c) 49. (c) 50. (d) 51. (b)

## Section-A

## JEE Advanced/ IIT-JEE

## A. Fill in the Blanks

- tert-butyl carbonium ion** is more stable due to hyperconjugation and +I effect of methyl groups.
- propadiene**; in it carbon-carbon is  $sp$  hybridised.
- cyclopropane**, because it has maximum deviation, from the normal bond angle of  $109^\circ 28'$  present in alkanes. In it bond angle is  $60^\circ$ .

$$d = \frac{1}{2}(109^\circ 28' - 60^\circ).$$

- $sp^3$
- vicinal, adjacent** (or stable, different).
- non-superimposable, enantiomers**;
- $sp$ ;
- Hyperconjugation**;
- Butane-1, 4-dioic acid**; Succinic acid has the formula.

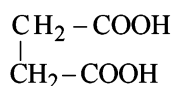

## B. True/False

- False** : Iodide is bigger in size than bromide, hence its electrons are more dispersed than that of bromide, with the result it is weaker nucleophile than bromide.
- False** : An electron-donating group increases the electron density in *o*- and *p*- positions due to +M, +E and/or +I effects and hence orients the new electrophile to *o*- and *p*- positions.
- False** : There are only two asymmetric (marked with \*) carbon atoms.

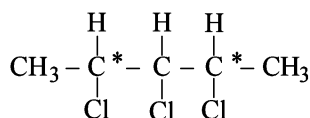

- True** : In  $S_N1$  (unimolecular nucleophilic substitution reaction), the leaving group leaves, thus producing a carbocation followed by the addition of the incoming group.

## C. MCQs with One Correct Answer

- (c) **NOTE**: The phenomenon of resonance gives identical bonding and hence identical bond lengths.

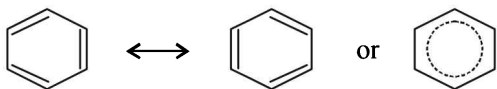

C - C bond order in benzene = 1.5

- (a) **TIPS/Formulae** :  
The bond length decreases in the order.

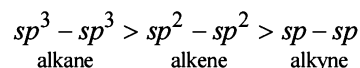

On the basis of the size of the hybrid orbitals,  $sp$  orbital should form the shortest and  $sp^3$  orbital the longest bond with other atom.

- (d) The first three are isomers of diethyl ether,  $C_2H_5OC_2H_5$  ( $C_4H_{10}O$ ).

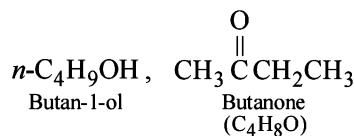
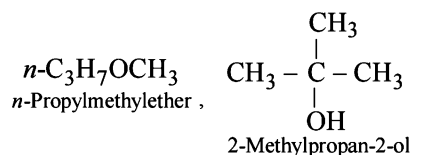

- (c) **TIPS/FORMULAE**:  
 $-\text{NO}_2$ ,  $-\text{Cl}$  and  $-\text{OH}$  are electron-attracting or withdrawing group due to  $-M$ ,  $-E$  and/or  $-I$  effects where as  $-\text{CH}_3$  show, +I effect (electron releasing).  
Because of the +I effect of the  $\text{CH}_3$  group, toluene has the highest electron density in the *o*- and *p*- positions and hence can be most readily sulphonated.

- (d)  $\begin{array}{c} 4 \quad 3 \quad 2 \quad 1 \\ \text{CH}_3 - \text{CH} = \text{C} = \text{CH}_2 \end{array}$   
Hybridisation in  $C_1 = sp^2$ ,  $C_2 = sp$ ,  $C_3 = sp^2$ ,  $C_4 = sp^3$ .
- (a) **TIPS/Formulae** :

*cis-trans* - Isomerism is due to restricted rotation either due to carbon-carbon double bond or due to cyclic structure.

**NOTE : Geometrical Isomerism** : The isomers which possess the same structural formula but differ in the spatial arrangement of the groups around the double bond are known as geometrical isomers.

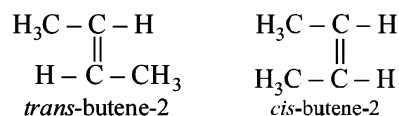

- (c)  $\begin{array}{c} \text{CH}_3 \\ | \\ \text{CH}_3 - \text{C} - \text{CH} = \text{CH}_2 \\ | \\ \text{CH}_3 \end{array}$   
3, 3-dimethylbut-1-ene

- (d)  $\text{CH}_3 - \text{O} - \text{CH}_3$  is an isomer of  $\text{CH}_3\text{CH}_2\text{OH}$   
dimethyl ether                  ethanol

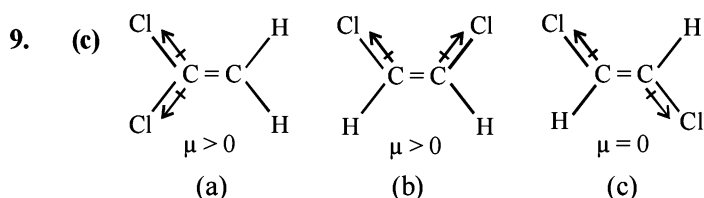

[Note : dipole moment is a vector quantity].

10. (c) Carbon bonded with a triple bond (i.e.  $C_1$ ) is  $sp$  hybridised. Carbon bonded with a double bond ( $C_2$ ) is  $sp^2$  hybridised.

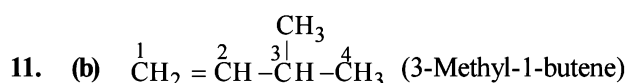

12. (b) **TIPS/Formulae :**

For knowing the possible isomers of the compound follow the following points.

- (i) First write down the possible number of isomeric parent alkane.  
 (ii) Introduce the given functional group at different positions so as to get different isomeric compound.

There are 5 isomers possible for  $C_6H_{14}$ .

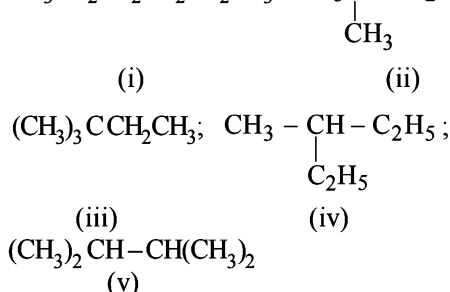
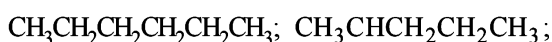

13. (a) **TIPS/Formulae :**

The bond angle in  $sp^3$ ,  $sp^2$  and  $sp$  hybridization is respectively  $109.28^\circ$ ,  $120^\circ$  and  $180^\circ$ .

Tetrachloroethene being an alkene has  $sp^2$  hybridised C-atoms and hence the Cl-C-Cl angle is  $120^\circ$ , whereas in tetrachloromethane, carbon is  $sp^3$  hybridised, so the angle is  $109.28^\circ$ .

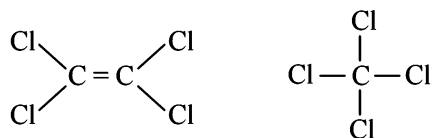

14. (d) **NOTE :** Heterolytic fission occurs when the two atoms differ considerably in their electronegativities.

O-H bond undergoes cleavage most readily because O and H differ markedly in their electronegativity and further oxygen being highly electronegative can accommodate the negative charge more effectively developed after the cleavage.

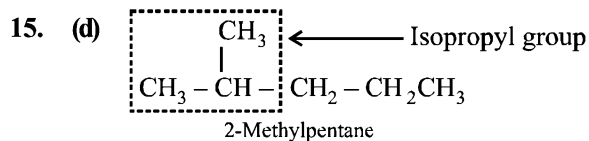

16. (c)  $C_2H_6$  is a saturated hydrocarbon and its carbon is  $sp^3$  hybridised. Hence it is least electronegative among alkanes, alkenes and alkynes with the result C-H bond length will be maximum.

17. (b)  $\text{CH}_2 = \text{CH} - \text{C} \equiv \text{CH}$ ;

No of  $\sigma$  bonds =  $2 + 1 + 1 + 1 + 1 + 1 = 7$ ;

No of  $\pi$  bonds =  $1 + 2 = 3$

18. (b) **NOTE :** The order of stability of carbonium ion is  
 tertiary > secondary > primary > methyl

Tertiary carbonium ions (formed in *b*) are more stable because of electron repelling (+I effect) nature of  $\text{CH}_3$  group due to which the +ve charge gets dispersed and also due to hyperconjugation.

19. (c)  $\text{HC} \equiv \overset{sp}{\text{C}} - \overset{sp^2}{\text{C}}\text{H} = \text{CH}_2$

20. (b)  $\text{C}_2\text{H}_5\text{SH} + \frac{9}{2}\text{O}_2(\text{g}) \rightarrow 2\text{CO}_2(\text{g}) + 3\text{H}_2\text{O}(\text{l}) + \text{SO}_2(\text{g})$

At 298 K,  $\text{CO}_2$  and  $\text{SO}_2$  exist as gases while  $\text{H}_2\text{O}$  exists as liquid.

21. (a) Stereoisomers which are mirror image of each other are *enantiomers* and the one which are not mirror images are *diastereomers*. **Conformation** of the molecule is the spatial arrangement of the atoms of a given molecular structure that are obtained merely by rotation about a sigma bond in the molecule.

22. (b) **NOTE :**

A compound which consists of at least one asymmetric carbon atom is capable of showing the phenomenon of optical isomerism.

The structure cannot show geometrical isomerism as one of the carbons along the double bond has identical group (methyl). Tautomerism is not possible because of the absence of -CO, group. It shows optical isomerism because it has chiral C atom with four different groups, H,  $\text{CH}_3$ , COOH and  $(\text{CH}_3)_2\text{C} = \text{CH}$ .

23. (c)  $\text{CH}_2 = \text{CH} - \text{CH}_2 - \text{N} \equiv \text{C} :$

The above structure of allyl isocyanide clearly shows 5 C-H( $\sigma$ ), 2 C-C( $\sigma$ ), 1 C-N( $\sigma$ ), 1 N-C( $\sigma$ ), 1 C-C( $\pi$ ), 2 N-C( $\pi$ ) bonds, i.e., 9 $\sigma$  and 3 $\pi$  bonds in all. There are 2 non-bonded electrons on the C-atom (co-ordinate bond between N and C, the electron pair of N is shifted towards C).

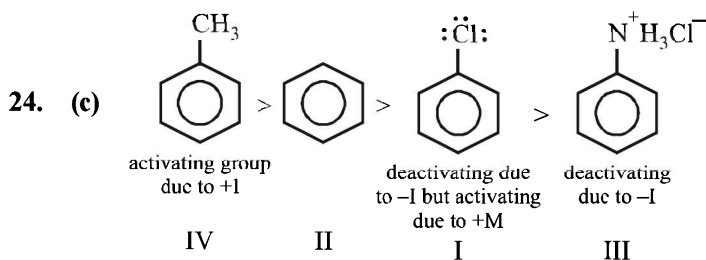

## 25. (d) TIPS/Formulae :

The stability of carbonium ion is influenced by both resonance and inductive effect.

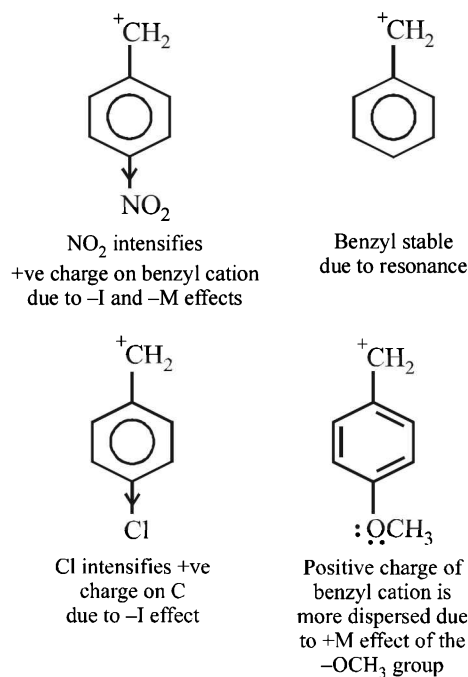
26. (d) NOTE :  $-\text{NO}_2$  is an electron-attracting group whereas  $-\text{CH}_3$  is an electron-releasing group.

An **electron-attracting substituent** tends to disperse the negative charge of the phenoxide ion and thus, makes it more stable. This, in turn, **increases the acid strength of phenol**. The substituent in para position is more effective than in the meta position as the former involves a resonating structure bearing negative charge on the carbon attached to the electron-withdrawing substituent.

An **electron-releasing substituent** tends to intensify the negative charge of the phenoxide ion and thus makes it more unstable. This, in turn, **decreases the acid strength of phenol**. Hence, the order of acid strength is

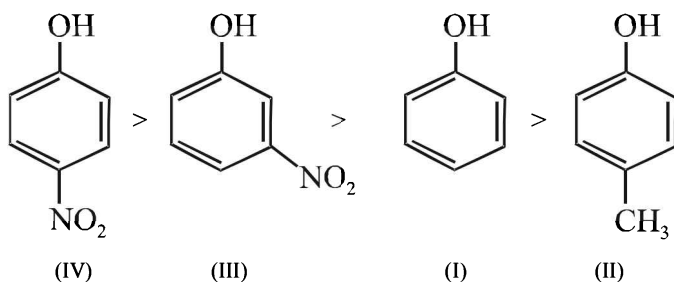
27. (b) Dipole moment of *p*-dichlorobenzene is zero because of symmetrical structure. *o*- and *m*-dichlorobenzene have higher dipole moments than toluene due to high electronegativity of chlorine than  $-\text{CH}_3$  group. Further, the *o*-dichlorobenzene has higher dipole moment due to lower bond angle than the *m*-isomer. Hence, the order of increasing dipole moment is :

*p*-dichlorobenzene (IV) < toluene (I)  
< *m*-dichlorobenzene (II) < *o*-dichlorobenzene (III)

## 28. (b) The stereoisomers of butane-2,3-diol are

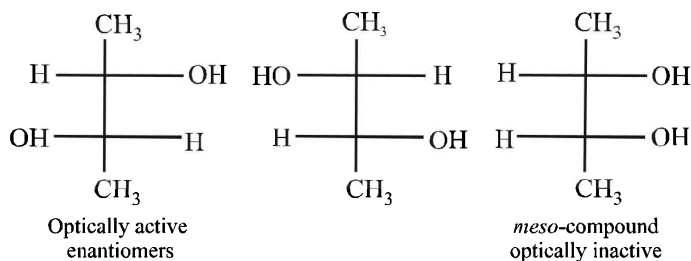
29. (d)  $\overset{1}{\text{CH}_2} = \overset{2}{\text{CH}} - \overset{3}{\text{CH}_2} - \overset{4}{\text{CH}_2} - \overset{5}{\text{C}} \equiv \overset{6}{\text{CH}}$ 

## 30. (c) TIPS/Formulae :

Glyceraldehyde is taken as arbitrary standard for D, L-nomenclature.

31. (a)  $\text{PhCH}_2\text{CH}=\text{CHCH}_3$  will exhibit geometrical isomerism because in others one of the doubly bonded carbon atom has two similar groups.32. (c)  $^-\text{CH}_3$  is the best nucleophile because carbon is least electronegative among the given options. The order is  $\text{H}_3\text{C}^- > \text{NH}_2^- > \text{OH}^- > \text{F}^-$ 33. (d) Rate of reaction will be  $\text{R}-\text{I} > \text{R}-\text{Br} > \text{R}-\text{Cl} > \text{R}-\text{F}$ , because  $\text{I}^-$  is the best, while  $\text{F}^-$  is the poorest leaving groups among halide ions.34. (b) In  $\text{CH}_3-\overset{\text{O}}{\parallel}{\text{C}}-\text{CH}_2-\overset{\text{O}}{\parallel}{\text{C}}-\text{CH}_2-\text{CH}_3$ ,  $-\text{CH}_2-$  group is flanked on both sides by electron-withdrawing groups and hence its hydrogens are most acidic. Once a carbanion is formed, it is stabilised due to resonance.

## 35. (d) Number of isomers (six) can be derived by keeping the position of any one halogen (say Br) fixed and changing the position of the other halogen one by one.

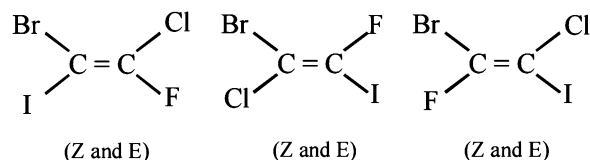
36. (d)  $\text{S}_{\text{N}}2$  reactions proceed with inversion of configuration. Since the attacking nucleophile is not necessarily the same as that of leaving group, the product cannot be enantiomer of the substrate and thus necessarily will not have opposite optical rotation. Moreover since only one product is obtained, we can not obtain diastereomers.

## 37. (d) 2-Methylbutanoic acid contains one asymmetric centre

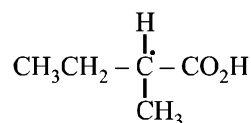

## 38. (c) TIPS/Formulae :

- (i) The inductive effect decreases with increase in distance of halogen atom from the carboxylic group and hence the strength of acid proportionally decreases.
- (ii) The acidity increases with the increase in electronegativity of the halogen present.

Smallest dissociation constant means weakest acid, which is  $\text{BrCH}_2\text{CH}_2\text{COOH}$  because here Br (less electronegative than F) is two carbon atoms away from  $-\text{COOH}$ .

39. (b) In carboxylic acids, molecules are more strongly associated followed by alcohols.

## 40. (c)

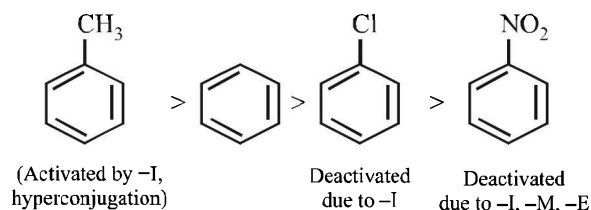

41. (b)
- $\text{CH}_3\text{C}\equiv\text{CCH}_3$
- is linear and symmetrical ; thus it has lowest dipole moment.

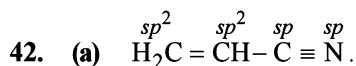

43. (a) NOTE : Dipole moment is a vector quantity.

Methane molecule being symmetrical, has zero dipole moment. Replacement of one of the H-atoms by Cl atom increases the dipole moment. The increase in dipole moment is rather more than what can be expected because of the fact that the bond dipole moment of C-H bond and that of C-Cl bond reinforce one another. Replacement of another H atom by Cl increases the bond angle due to lone pair - lone pair repulsion between two Cl-atoms thereby reducing the dipole moment of the molecule. Increase in angle is again caused by the the introduction of the third Cl-atom. When the fourth Cl-atom is introduced, the molecule ( $\text{CCl}_4$ ) again becomes symmetrical and dipole moment reduces to zero. So,  $\text{CH}_3\text{Cl}$  will have the maximum dipole moment.

## 44. (c) TIPS/Formulae :

Any conformation between two extreme positions i.e. eclipsed and staggered is known as Gauche or Skew form.

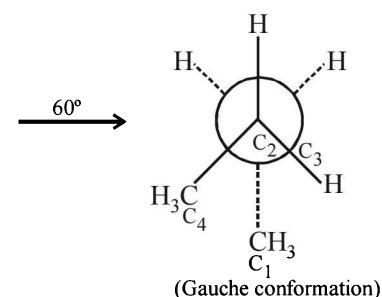
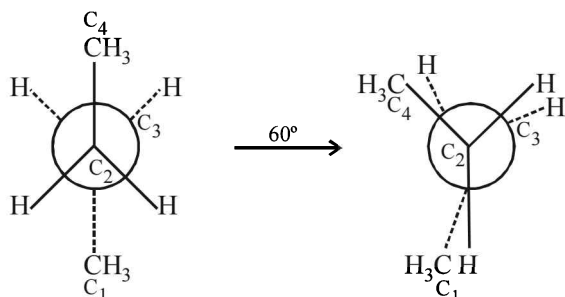

45. (c) Structures (a) and (b) are quite stable because here every atom has complete octet; in structures (c) and (d), every atom does not have complete octet; hence these are less stable than (a) and (b). However, structure (d) is stabilised by resonance, which is not possible in (c). Hence (c) is least stable.

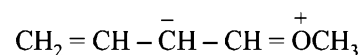
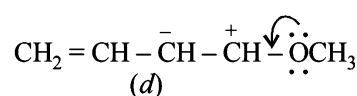
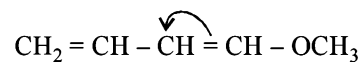
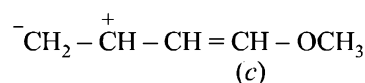
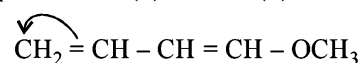

46. (a) NOTE : This is an example of
- $\text{S}_{\text{N}}1$
- reaction involving carbocation as intermediate.

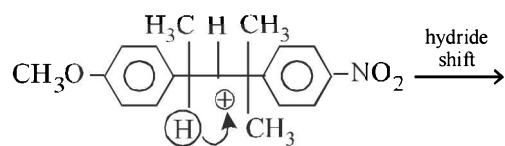
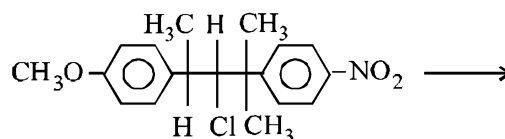

(A) 2° Carbocation

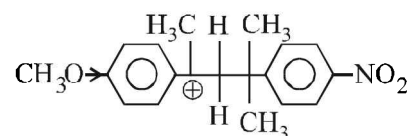
(B) 3° Carbocation; more stable; (positive charge is dispersed due to +M effect of  $-\text{OCH}_3$ )

This carbocation is especially stabilised through resonance in which  $-\ddot{\text{O}}-\text{CH}_3$  group acts as a good electron donor.

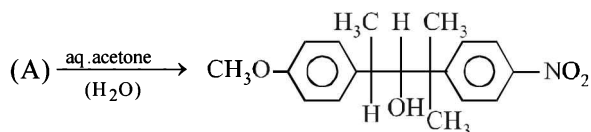

(i)

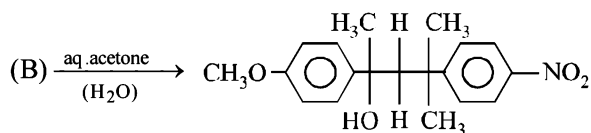

(ii)

47. (b) Carboxylic acids are named as *oyl chlorides*.
48. (b) The ring to which  $-\text{NH}$  group is attached is activated due to the lone pairs on N (+M and +E effects); while the ring to which  $-\text{C}=\text{O}$  is attached is deactivated. Here, the electrophile would go to the *para*-position of the activated ring.
49. (a) Due to similar charges on adjacent atoms, the structure (a) is least stable.
50. (a) Anti addition of  $\text{Br}_2$  on *trans* alkene provides meso compound.

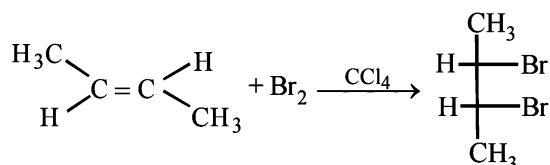

51. (b) Alkyl groups with at least one hydrogen atom on the  $\alpha$ -carbon atom, attached to an unsaturated carbon atom, are able to release electrons in the following way.

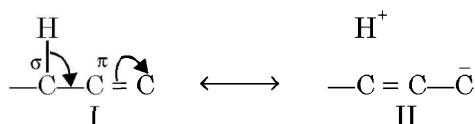

Note that the delocalisation involves  $\sigma$  and  $\pi$  bond orbitals (or  $p$  orbitals in case of free radicals); thus it is also known as  $\sigma-\pi$  conjugation. This type of *electron release due to the presence of the system*  $\text{H}-\text{C}-\text{C}=\text{C}$  is known as **hyperconjugation**

52. (d) The correct stability order is  
I > III > II > IV

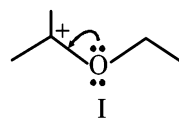

+ M effect, 6 hyperconjugative H's, 2  $\text{CH}_3$  groups (+I effect)

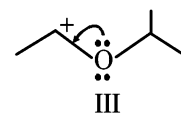

+ M, 3 hyperconjugative H's, one  $\text{CH}_3$  group

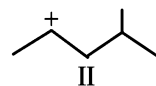

5 hyperconjugative CO-H's 2 R groups

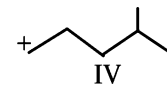

5 hyperconjugative H's one R groups

53. (b)  $-\text{CN}$  has highest priority. Further the sum of locants is 7 in (b) and 9 in (d).
54. (d) **NOTE**: Migrating tendency of hydride is greater than that of alkyl group. Further migration of hydride from C-2 gives more stable carbocation (stabilized by +R effect of OH group and +I and hyperconjugative effects of methyl group).

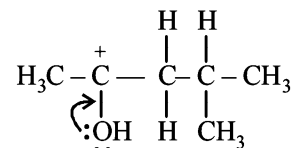
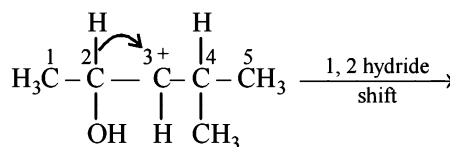

More stable carbocation

55. (c) *o*-Hydroxybenzoic acid is strongest acid and the decreasing order of acidity is

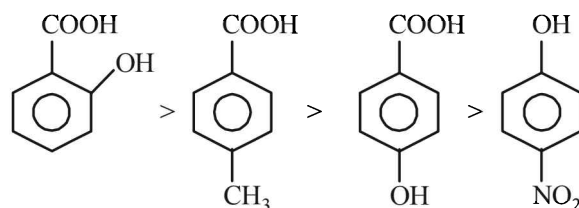

56. (b)

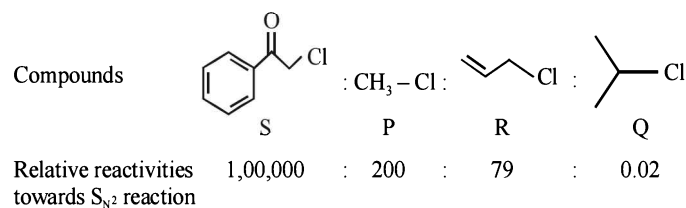

## D. MCQs with One or More Than One Correct

- (a,b,c) Resonating structures differ in bonding pattern.
- (a, c) Higher the stability of the corresponding anion, more will be the acidic character of the parent compound.

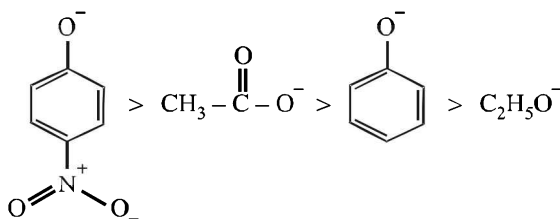

Higher stability of acetate ions than phenoxide ion is due to equivalent resonating structures in the former

- (b, d) 1, 4-Dichlorobenzene (*p*-dichlorobenzene) and *trans*-1, 2-dichloroethene have zero dipole moment because of their symmetrical structures.
- (a, d) In *n*-butane, Cl can add at either the first or second carbon giving two isomers.

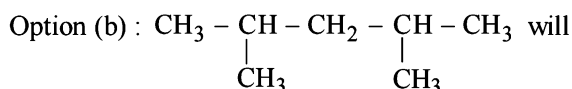

give three isomers with Cl group at either of the  $\text{CH}_3$  groups, second C-atom and 3rd C-atom. Benzene forms only one single derivative.

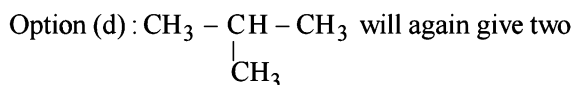

isomers with Cl at either one of the  $\text{CH}_3$  groups or on the central C-atom.

- (c, d) An asymmetric carbon atom is one which is attached with 4 different groups. Hence (c) & (d) are correct.
- (a) **TIPS/Formulae :**  
Conjugate base of strong acid is weak while conjugate base of a weak acid is stronger.  
Acidic strength of acids,  
 $\text{HOH} > \text{CH} \equiv \text{CH} > \text{NH}_3 > \text{CH}_3, \text{CH}_3$   
Hence the order of strength of bases,  
 $\text{CH}_3\text{CH}_2^- > \text{NH}_2^- > \text{CH} \equiv \text{C}^- > \text{OH}^-$

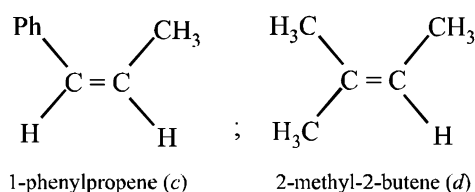
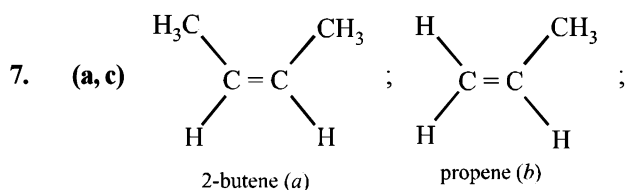

Only 2-butene and 1-phenylpropene can show geometrical isomerism (*cis*- and *trans*-isomers).

- (d) Order of acidic strength  
 $\text{CH}_3\text{OH} > \text{CH} \equiv \text{CH} > \text{C}_6\text{H}_6 > \text{C}_2\text{H}_6$ ;  $\text{CH}_3\text{OH}$  is most acidic because O is more electronegative than C and capable of accommodating negative charge in  $\text{CH}_3\text{O}^-$ . Although alcohols are neutral towards the litmus paper.

- (a,c,d) **TIPS/Formulae :**  
For a carbonyl compound to show tautomerism, it must have at least one H at the  $\alpha$ -carbon atom.  
(a), (c) and (d) show tautomerism.

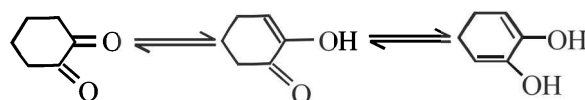
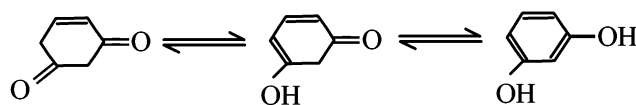
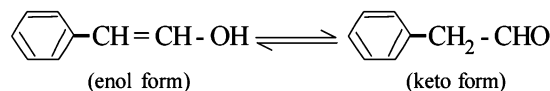

- (b,c,d) **NOTE :** An aromatic species will have :  
 $(4n + 2) \pi$  electrons (by Huckel's Rule)  
planar structure (due to resonance)  
cyclic structure (due to presence of  $sp^2$ -hybrid carbon atoms).
- (b,c,d) E and F ; and also E and G differ in position of atom (H), so these are tautomers (not resonating structures). Geometrical isomers are also diastereomers).
- (a, d) The given molecule although possesses neither centre of symmetry nor a plane of symmetry (hence optically active) but it has an axis of symmetry ( $C_n$ ).  
**NOTE :** A  $C_n$  axis of symmetry is an axis about which the molecule can be rotated by  $360^\circ/n$  to produce a molecule indistinguishable from the original molecule.

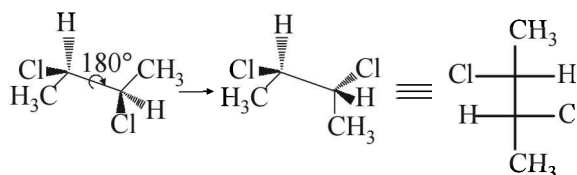

Molecule has non-superimposable mirror image

- (a,d)  $\text{CH}_3 - \overset{*}{\text{C}}\text{H}(\text{OH}) - \text{CH} = \text{CH} - \overset{*}{\text{C}}\text{H}(\text{OH}) - \text{CH}_3$

Stereoisomer	Configuration
I	<i>d cis d</i>
II	<i>l cis l</i>
III	<i>d cis l</i>
IV	<i>d trans d</i>
V	<i>l trans l</i>
VI	<i>d trans l</i>

Enantiomers I and II; IV and V  
*cis trans*  
Diastereomers I (or II), III (or IV), V and VI  
Meso III and IV

14. (b, d)

Structural formula of 2, 2-dimethylbutane is

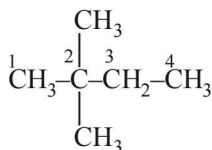
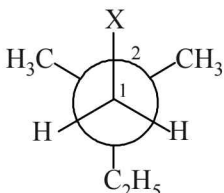
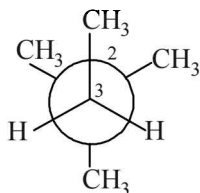
(I) Newman projection using  $C_1-C_2$  bond(II) Newman projection using  $C_3-C_2$  bond

16. (b, c)

b and c, being antiaromatic, are unstable at room temperature.

17. (a, b, c)

Converting all the structures in the Fischer projection

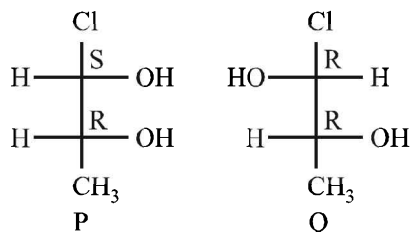
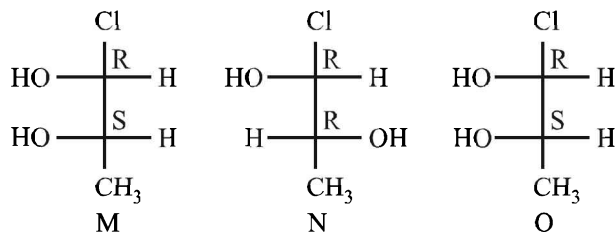

M and N are diastereoisomers

M and O are identical

M and P are enantiomers

M and Q are diastereoisomers

Hence, the correct options are a, b, c.

18. (a)

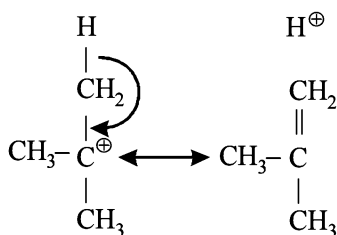

In tert butyl cation, carbon bearing positive charge has one vacant  $p$ -orbital hence it is  $\sigma$ - $p$  (empty) conjugation or hyperconjugation.

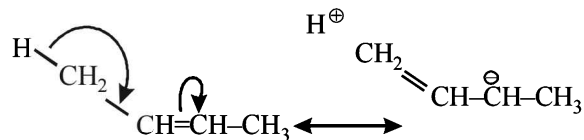
In 2-butene, hyperconjugation is between  $\sigma \rightarrow \pi^*$  bond.

### E. Subjective Problems

1. (i) **TIPS/Formulae :**

It is a case of nucleophilic addition reaction. More the electron deficiency of the carbonyl carbon, greater will be its reactivity towards nucleophilic addition.



(ii) Isobutane <  $n$ -Butane <  $n$ -Butyl chloride <  $n$ -Butanol  
 van der Waals forces                  dipole-dipole                  H-bonding  
    attraction

Straight chain alkane isomer has higher boiling point than the isomeric branched chain isomer because the former isomer has larger surface area which leads to large vander Waals attractive forces.

(iii) **NOTE :**  $-OCH_3$  and  $-CH_3$  groups are activating group while  $-Cl$  is a deactivating group for electrophilic substitution.

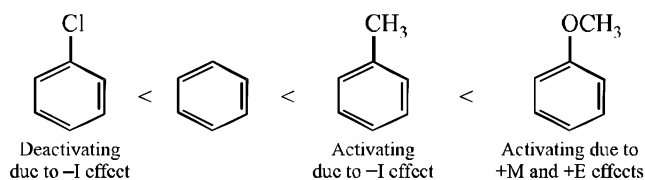

(iv) Presence of electron withdrawing group increases the acidic character of the  $-COOH$  due to  $-I$  effect, while presence of electron-donating group (alkyl groups) decreases the acidic character due to  $+I$  effect. Thus



(v) **NOTE :** A weaker base is a better leaving group.

Rate of reaction will be  $R-I > R-Br > R-Cl > R-F$ . because  $I^-$  is the best, while  $F^-$  is the poorest leaving groups among halide ions.

2. (i)  $CH_3CH_2CH=CHCOOH$ 

Pent-2-en-1-oic acid Or 2-Pentenoic acid

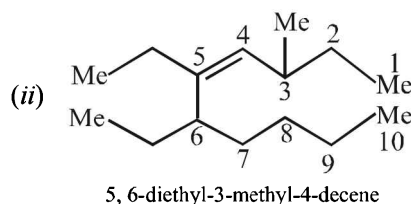

(ii) IUPAC name is

3-(N, N-dimethylamino)-3-methylpentane.

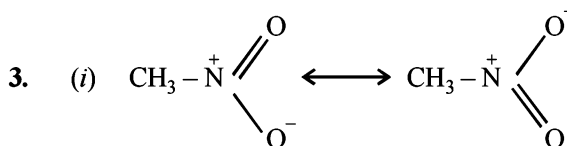



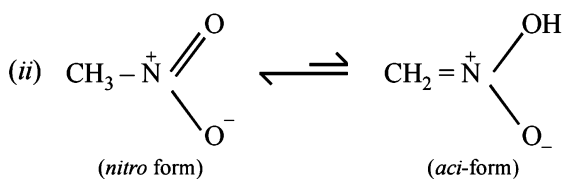

4. (i) In formic acid, resonance is not possible with the result there are two types of C–O bonds. In sodium formate, resonance is possible, so both of the C–O bonds have same bond length.

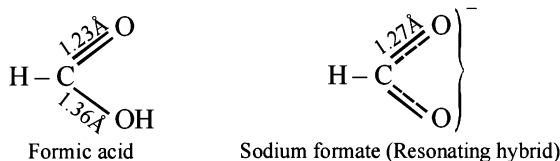

- (ii) In biphenyl, one of the phenyl groups acts as electron donor and the other electron acceptor due to mesomeric effect. This makes it more reactive than benzene.

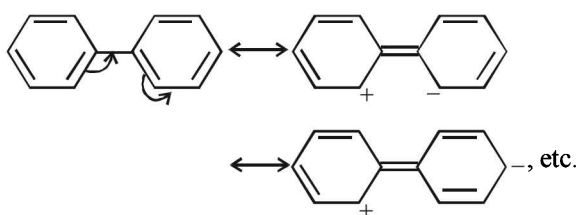

- (iii) The low reactivity of halogen atom in aryl and vinyl halides towards nucleophiles is due to resonance.

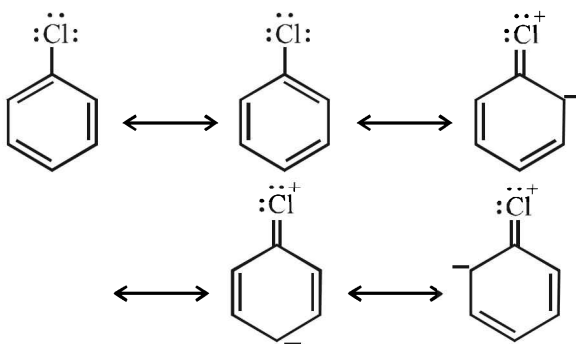

Resonating structures of chlorobenzene

**NOTE :** Due to resonance, carbon-chlorine bond acquires partial double bond character, hence it becomes shorter and stronger and thus cannot be easily replaced by nucleophiles.

- (iv)  $\text{CH} \equiv \text{C}^-$ ,  $\text{C}^-$  is  $sp$  hybridised and more electronegative than the  $\bar{\text{C}}\text{H}$  of  $\text{CH}_2 = \bar{\text{C}}\text{H}$  which is  $sp^2$  hybridised. Thus the former can better accommodate electron pair hence less basic.
- (v) Benzene gives electrophilic substitution reaction rather than electrophilic addition reactions because it will have a stable benzene ring in the product, whereas electrophilic addition on benzene destroys the benzenoid ring.
5.  ${}^5\text{CH}_3 - {}^4\underset{\text{Cl}}{\text{CH}} - {}^3\text{CH} = {}^2\text{CH} - {}^1\text{CH}_3$

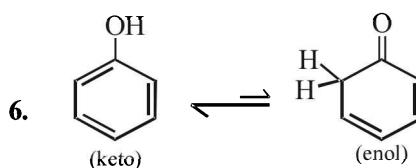

7. *cis*-Alkenes add bromine to form racemic mixture.

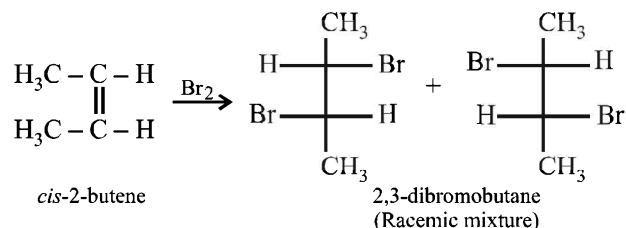

8.  $\text{CH}_2 = \text{C} = \text{CH}_2$  (Allene)
- $sp^2 \quad sp \quad sp^2$

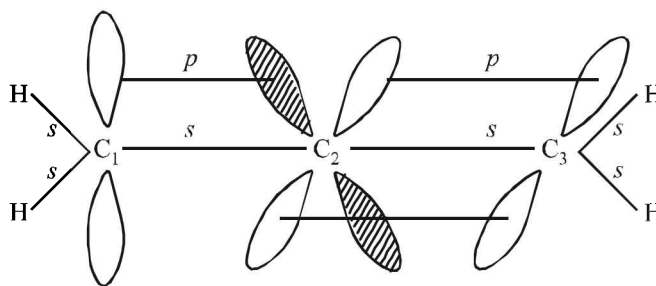

9. In order to convert a molecule with two stereogenic centres to its enantiomer, the configuration at both centres must be reversed. Reversing the configuration at only one stereogenic centre converts it to a diastereomeric structure. Thus structures I and III are enantiomers; while structures I and II as well as II and III are diastereomers.

#### 10. TIPS/Formulae :

Diethyl ether acts as a lewis base and anhydrous  $\text{AlCl}_3$  as a lewis acid.

Anyhydrous  $\text{AlCl}_3$  is more soluble in diethyl ether because the oxygen atom of ether donates its pair of electrons to the vacant orbital of electron deficient aluminium of  $\text{AlCl}_3$  through the formation of coordinate bond. In case of hydrated  $\text{AlCl}_3$  aluminium is not electron deficient as oxygen atom of water molecule has already donated its pair of electrons to meet the electron deficiency of aluminium.

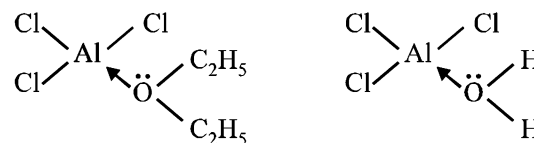

11. **NOTE :** Higher the  $K_a$  value, more stronger is the acid. Correct order of acidic strength of the given acids is

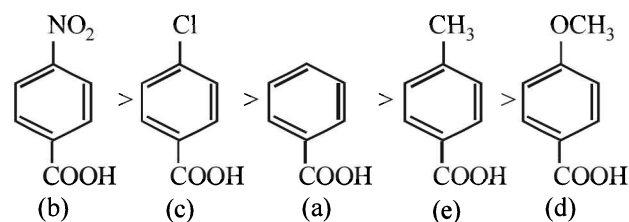

Hence the  $K_a$  values of the five acids will be in the order.

(b) (c) (a) (e) (d)  
 $K_a$  value  $30.6 \times 10^{-5}$   $10.2 \times 10^{-5}$   $6.4 \times 10^{-5}$   $4.2 \times 10^{-5}$   $3.3 \times 10^{-5}$

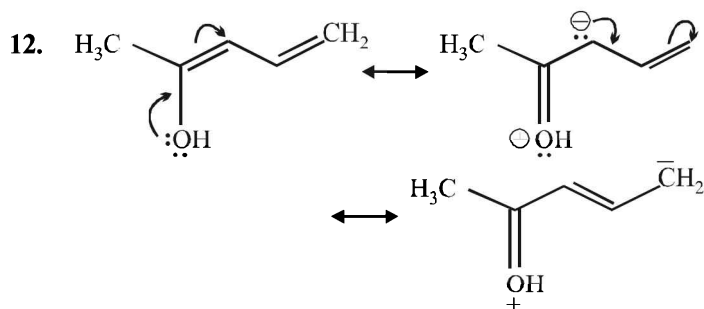

13. Presence of an electron-attracting group increases acidity of the compound. Thus

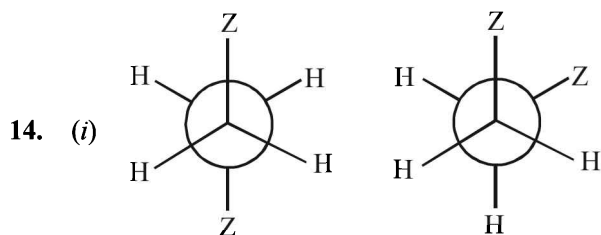
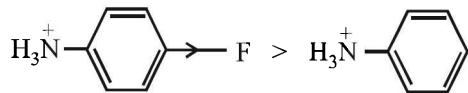

Anti conformer      Gauche conformer  
 Given, mole fraction of anti conformer = 0.82  
 $\therefore$  mole fraction of gauche conformer = 0.18

$$\mu_{\text{ob.}} = \mu_{\text{anti}} \times \chi_{\text{anti}} + \mu_{\text{gauche}} \times \chi_{\text{gauche}}$$

$$1 = \mu_{(\text{anti})} \times 0.82 + \mu_{(\text{gauche})} \times 0.18$$

$$1 = 0 \times 0.82 + \mu_{(\text{gauche})} \times 0.18 \quad [\because \mu_{(\text{anti})} = 0]$$

$$\therefore 1 = \mu_{(\text{gauche})} \times 0.18$$

$$\mu_{(\text{gauche})} = \frac{1}{0.18} = 5.55 \text{ D}$$

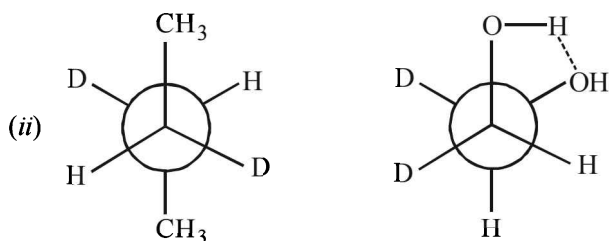

### F. Match the Following

1. (A) - q; (B) - p, s; (C) - r, s; (D) - q

E1 mechanisms are encountered only with tertiary or secondary substrates and in presence of either a weak base or a base in low concentration. So primary substrates will follow E2 mechanism, i.e. (A)  $\rightarrow$  E2 and (D)  $\rightarrow$  E2.

Further E1 mechanism (similar to  $S_N1$ ) proceeds by first order kinetics and is determined by the slower (first) step of the formation of carbocation. Hence (B)  $\rightarrow$  E1 and first order reaction.

**NOTE THIS STEP:** Reaction of  $C_6H_5CH_2CH_2Br$  on treatment with  $C_2H_5O^-$  in presence of  $C_2H_5OD$  gives  $C_6H_5CD=CH_2$ . This reaction follows E1CB (Elimination unimolecular conjugate base) mechanism. This 2 step mechanism follows the following path:

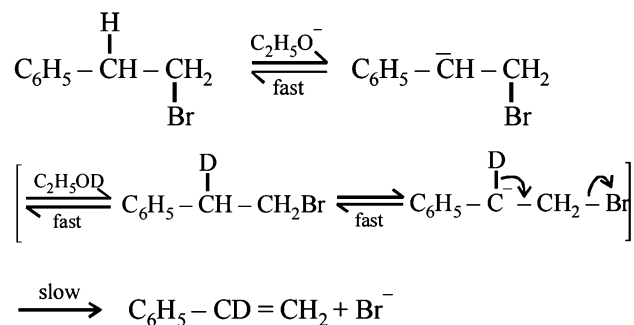

(formation of carbanion and elimination of Br from carbanion)

Although this mechanism involves 2 steps the overall rate of the reaction is limited to the slower second step and hence the rate of reaction depends only on the concentration of the carbanion, i.e. first order reaction. Hence, (C)  $\rightarrow$  (r), (s).

2. (A) - p, q, s; (B) - q; (C) - q, r, s; (D) - q, r

(A)  $C_6H_5CHO$  forms ppt. of 2, 4-dibromophenylhydrazone (p), forms silver mirror with ammonical silver nitrate - Tollen's reagent (q), forms cyanohydrin with  $CN^-$  (s).

(B)  $CH_3C \equiv CH$  gives ppt. with  $AgNO_3$  (q)

(C)  $CN^-$  reacts with  $AgNO_3$  to form ppt. of  $AgCN$  (q), it is a nucleophile (r) and forms cyanohydrin (s)

(D)  $I^-$  gives ppt. of  $AgI$  with  $AgNO_3$  (q), and it is a nucleophile (r)

3. (A) - p, q, t; (B) - p, s, t; (C) - r, s; (D) - p

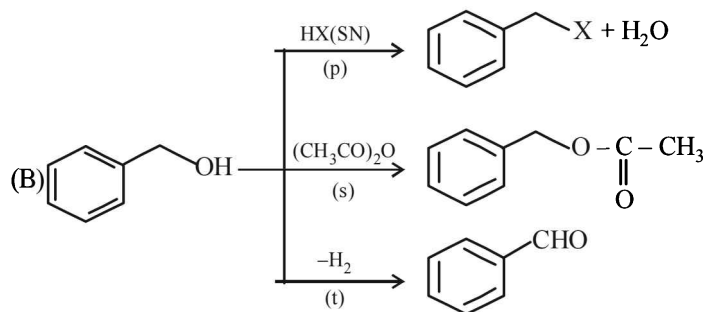
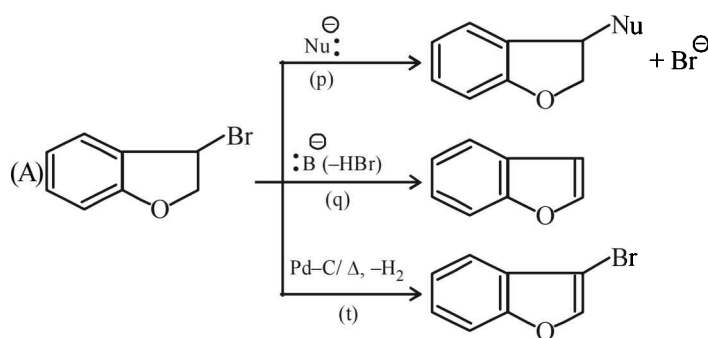

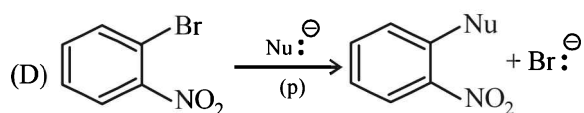
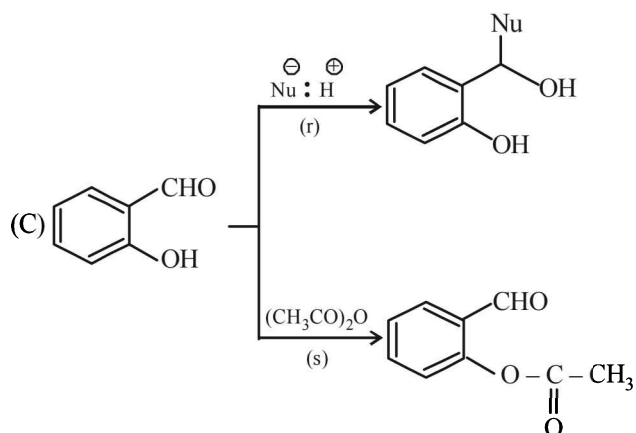

4. A - r, s, t; B - p, s; C - r, s; D - q, r

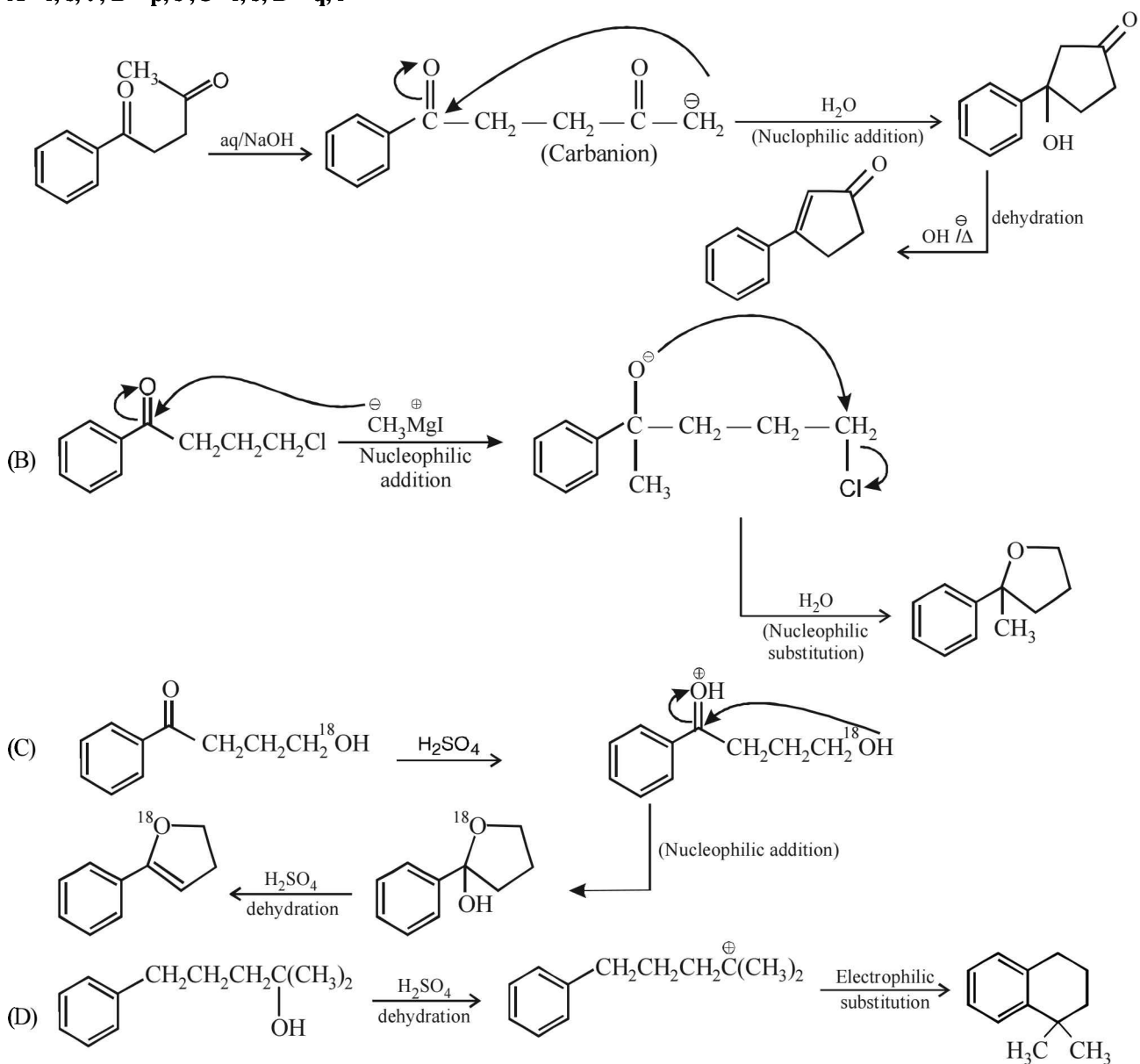

### H. Assertion & Reason Type Questions

- (d) Statement -1 is false because aryl halides do not undergo nucleophilic substitution under ordinary conditions. This is due to resonance, because of which the carbon-chlorine bond acquires partial double bond character, hence it becomes shorter and stronger and thus cannot be replaced by nucleophiles.
- (a) Due to +M effect of  $-\ddot{O}H$ , its intermediate carbocation is more stable than the one in benzene.
- (c) Statement-1 is correct. Statement-2 is incorrect because compound can be chiral even in the absence of chiral atoms.

### I. Integer Value Correct Type

- The seven possible cyclic structural and stereoisomers are

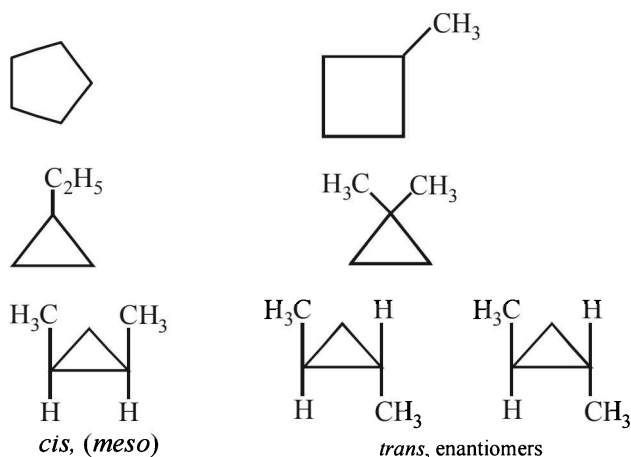

- The number of cyclic isomers for a hydrocarbon with molecular formula  $C_4H_6$  is 5. The structures are

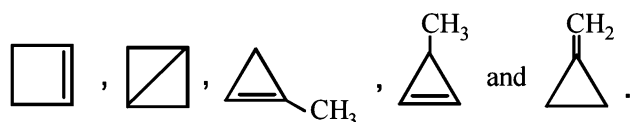

- 8

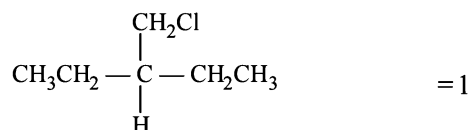
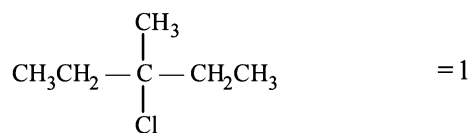
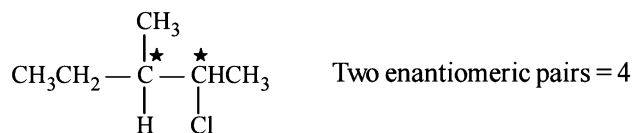
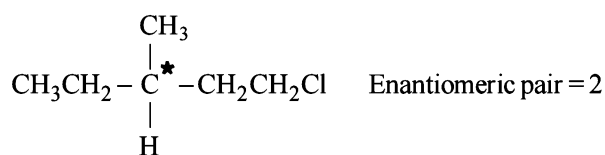

$$\text{Total} = 2 + 4 + 1 + 1 = 8$$

- 6

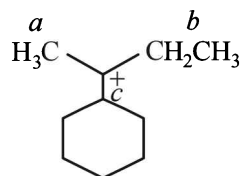

$a = 3$  Hyperconjugative H's

$b = 2$  Hyperconjugative H's

$c = 1$  Hyperconjugative H

- (3)

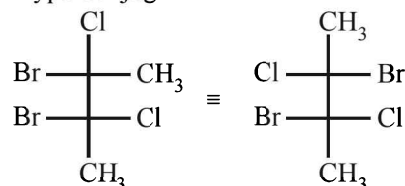

Following three conformers (with  $\mu \neq 0$ ) are possible

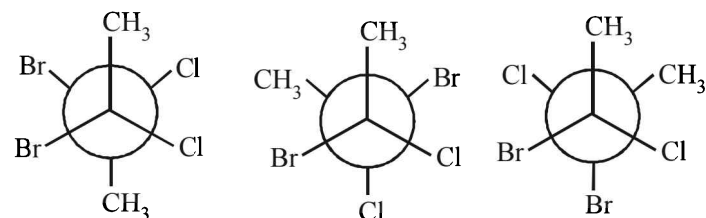

- (2) The molecule cannot show geometrical isomerism, so only its mirror image will be the other stereoisomer.

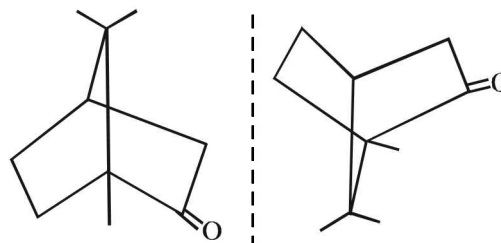

## Section-B JEE Main/ AIEEE

1. (b)  $-\text{CH}_3$  group has +I effect, as number of  $-\text{CH}_3$  group increases, the inductive effect increases. Therefore the correct order is

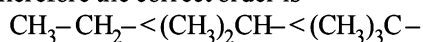

2. (c) Stereoisomerism involve those isomers which contain same ligands in their co-ordination spheres but differ in the arrangement of these ligands in space. Stereoisomerism is of two type geometrical isomerism and optical isomerism. In geometrical isomerism ligands occupy different positions around the central metal atom or ion.

**NOTE :** In optical isomerism isomers have same formula but differ in their ability to rotate directions of the plane of polarised light.

3. (c)  $\begin{array}{l} \text{Cl} \\ \diagdown \\ \text{C}=\text{CH}-\text{CH}_2-\text{CH}_2\text{CH}_3 \\ \diagup \\ \text{Cl} \end{array}$  does not show

geometrical isomerism due to presence of two similar Cl atoms on the same C-atom. Geometrical isomerism is shown by compounds in which the groups/atoms attached to C = C are different.

4. (d) Amino acids contain  $-\text{NH}_2$  and  $-\text{COOH}$  groups e.g

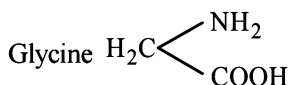

5. (c) The correct name is 3-methylbut-2-one

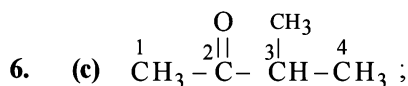

3-methyl-2-butanone

7. (b) In molecules (a), (c) and (d), the carbon atom has a multiple bond, only (b) has  $\text{sp}^3$  hybridization.

8. (d) A mixture of equal amount of two enantiomers is called a racemic mixture. A racemic mixture does not rotate plane-polarized light. They are optically inactive because for every molecule in a racemic mixture that rotate plane of polarized light in one direction, there is a mirror image molecule that rotates the plane in opposite direction.

9. (d) **TIPS/Formulae :**

Stereoisomerism is of two types i.e., geometrical isomerism and optical isomerism

Both the structures shows stereoisomerism. Structure I shows geometrical isomerism as it contains two different atoms(H) and groups ( $\text{CH}_3$ ) attached to each carbon containing double bond.

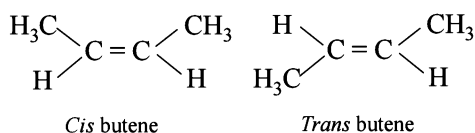

Structure II shows optical isomerism as it contains a chiral carbon (attached to four different group) atom.

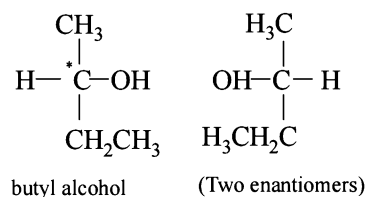

10. (b) The hydrolysis of t-butyl bromide is an example of  $\text{S}_{\text{N}}1$  reaction. The reaction consists of two steps.

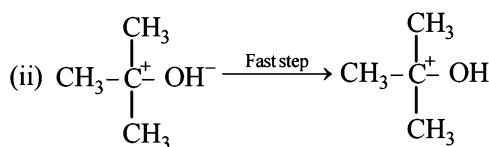
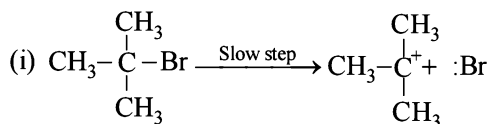

11. (d)  $\text{HCOO}^-$  exists in following resonating structures

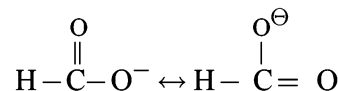

Hence in it both the carbon oxygen bonds are found equal.

12. (a)  $\text{C}_n\text{H}_{2n}\text{O}_2$  is general formula for carboxylic acid

13. (a)

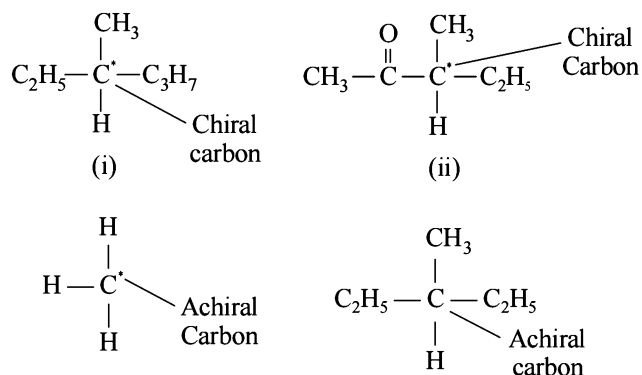

14. (d) **NOTE :** Among isomeric alkanes, the straight chain isomer has higher boiling point than the branched chain isomer. The greater the branching of the chain, the lower is the boiling point. Further due to the presence of  $\pi$  electrons, these molecules are slightly polar and hence have higher boiling points than the corresponding alkanes.

Thus B.pt. follows the order  
alkynes > alkene > alkanes (straight chain) > branched chain alkanes.

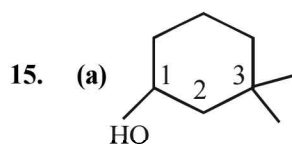

IUPAC name – 3,3-Dimethyl -1 cyclohexanol

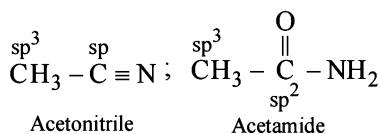
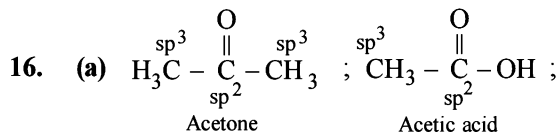

17. (b) **NOTE :** The compounds containing two similar asymmetric C-atoms have plane of symmetry and exist in Meso form.

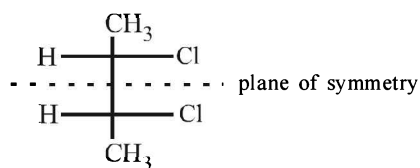

Meso 2, 3 dichlorobutane

18. (c)  $\text{Cl}^-$  is the best leaving group among the given option.  
19. (a) Only 2- cyclopropyl butane has a chiral centre.

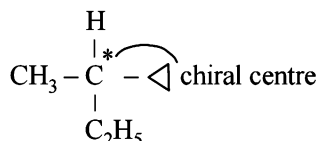

20. (d) In aromatic acids presence of electron withdrawing substituent e.g.  $-\text{NO}_2$  disperses the negative charge of the anion and stabilises it and hence increases the acidity of the parent benzoic acid. Further *o*-isomer will have higher acidity than corresponding *m* and *p* isomers. Since nitro group at *p*-position have more pronounced electron withdrawing than  $-\text{NO}_2$  group at *m*-position hence the correct order is the one given above.

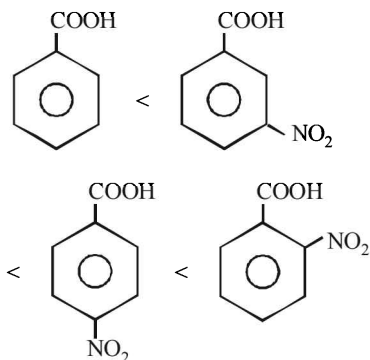

21. (d) Lone pair of electrons present on the nitrogen of benzyl amine is not involved in resonance.

22. (c) 1-chloropentane is not chiral while others are chiral in nature

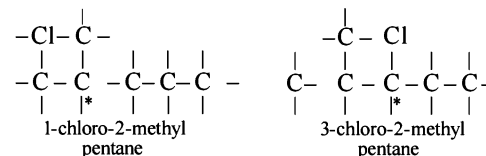
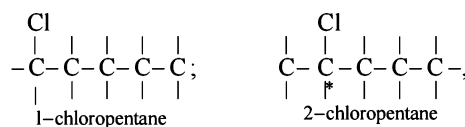

23. (d) Free radicals are electrically neutral, unstable and very reactive on account of the presence of odd electrons.  
24. (a) In moving down a group, the basicity and nucleophilicity are inversely related, *i.e.* nucleophilicity increases while basicity decreases. In going from left to right across a period, the basicity and nucleophilicity are directly related. Both of the characteristics decrease as the electronegativity of the atom bearing lone pair of electrons increases. If the nucleophilic centre of two or more species is same, nucleophilicity parallels basicity, *i.e.* more basic the species, stronger is its nucleophilicity. Hence based on the above facts, the correct order of nucleophilicity will be

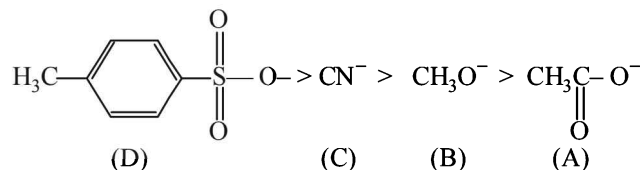

25. (d)  $\text{R} - \overset{\text{O}}{\parallel}{\text{C}} - \text{X}$  ; when X is Cl the C-X bond is more polar and ionic which leaves the compound more reactive for nucleophilic substitution reaction.

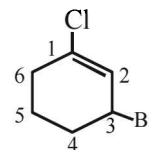

3-bromo-1 chlorocyclohexene

27. (b) The order of stability of free radicals  
 $(\text{C}_6\text{H}_5)_3\dot{\text{C}} > (\text{C}_6\text{H}_5)_2\dot{\text{C}}\text{H} > (\text{CH}_3)_3\dot{\text{C}} > (\text{CH}_3)_2\dot{\text{C}}\text{H}$   
The stabilisation of first two is due to resonance and last two is due to inductive effect.

28. (c) **TIPS/Formulae :**  
The stronger the acid, the weaker the conjugate base formed.

The acid character follows the order :



The basic character will follow the order

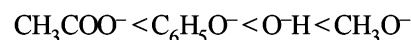

29. (b) **Hofmann's rule** : When theoretically more than one type of alkenes are possible in eliminations reaction, the alkene containing least alkylated double bond is formed as major product. Hence

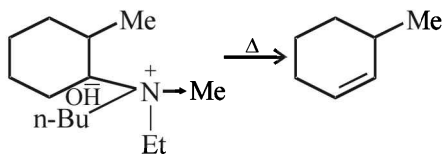

**NOTE** : It is less sterically  $\beta$ -hydrogen is removed

30. (a)

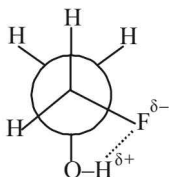

Due to hydrogen bonding between H & F gauche conformation is most stable hence the correct order is

Eclipse, Anti, Gauche

31. (a)
- $$\text{CH}_3 - \text{CH}_2 - \text{CH}_2 - \underset{\substack{\text{CH}_3 \\ | \\ \text{CH}_3}}{\text{C}} - \underset{\substack{\text{CH}_2 \\ | \\ \text{CH}_3}}{\text{CH}} - \text{CH}_2 - \text{CH}_3$$
- 7      6      5      4      3      2      1
- 3-ethyl-4,4-dimethyl heptane

32. (b) **NOTE** : The organic compounds which have chiral carbon atom (a carbon atom attached to four different group or atoms and do not have plane of symmetry) rotate plane polarised light.

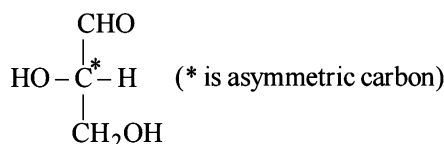

33. (a) Nitro group is electron withdrawing group, so it deactivates the ring towards electrophilic substitution.
34. (b) Chiral conformation will not have plane of symmetry. Since twist boat does not have plane of symmetry it is chiral.

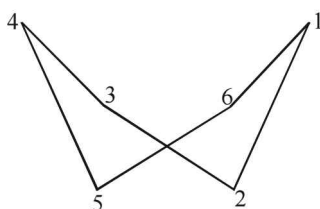

35. (b) The absolute configuration is (R, R) (using priority rules to get the absolute configuration) So the correct answer is (b)

36. (b) In option (b) the complex formed is with benzene where as in other cases it is formed with nitrobenzene with  $-\text{NO}_2$  group in different position (o-, m-, p-). The complex formed with nitrobenzene in any position of  $-\text{NO}_2$  group is less stable than the complex formed with benzene so the correct answer is (b)

**NOTE** : The most stable complex has lowest energy.

37. (a) The correct order of priority for the given functional group is

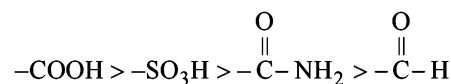

38. (a)

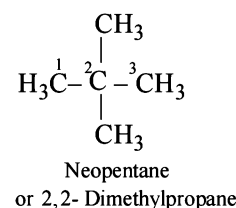

39. (b)

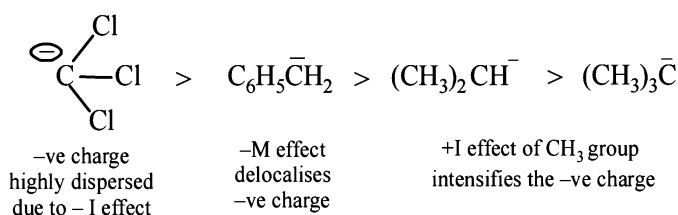

40. (b)
- 

41. (b)  $\text{CH}_3 - \text{CH} = \text{CH} - \overset{*}{\underset{\text{OH}}{\text{C}}} \text{HCH}_3$

exhibits both geometrical as well as optical isomerism.

*cis* - R

*cis* - S

*trans* - R

*trans* - S

42. (d) The correct order of basicity is  $\text{RCOO}^- < \text{CH} \equiv \text{C}^- < \text{NH}_2^- < \text{R}^-$

43. (c) For a compound to show optical isomerism, presence of chiral carbon atom is a necessary condition.

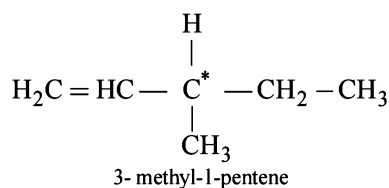

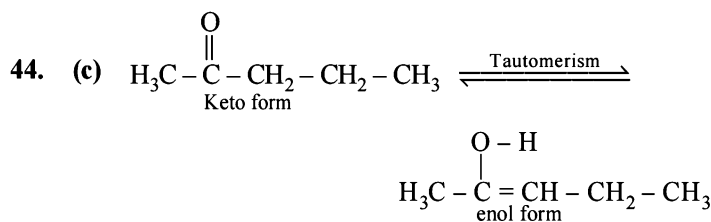

45. (c)

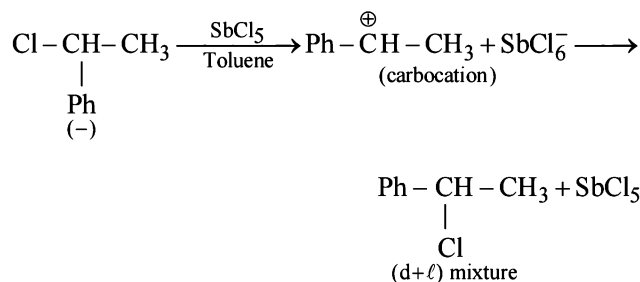

46. (d) Higher stability of allyl and aryl substituted methyl carbocation is due to dispersal of positive charge due to resonance

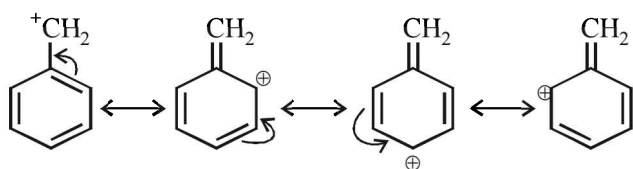
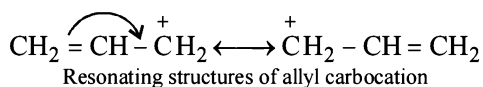

Resonating structures of benzyl carbocation

whereas in alkyl carbocations dispersal of positive charge on different hydrogen atoms is due to hyper conjugation hence the correct order of stability will be

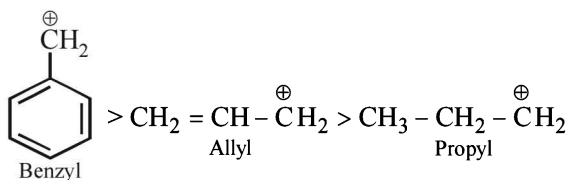

47. (b) 
$$\% \text{ of N} = \frac{1.4 \times \text{meq. of acid}}{\text{mass of organic compound}}$$

$$\text{meq. of H}_2\text{SO}_4 = 60 \times \frac{M}{10} \times 2 = 12$$

$$\text{meq. of NaOH} = 20 \times \frac{M}{10} = 2$$

$$\therefore \text{meq. of acid consumed} = 12 - 2 = 10$$

$$\therefore \% \text{ of N} = \frac{1.4 \times 10}{1.4} = 10\%$$

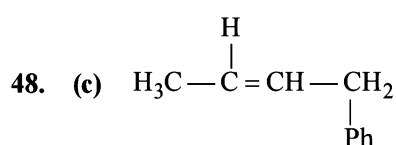

1-Phenyl-2-butene the two groups around each of the doubly bonded carbon

Because, all are different. This compound can show *cis*- and *trans*-isomerism.

49. (c) Mass of substance = 250 mg = 0.250 g  
Mass of AgBr = 141 mg = 0.141 g  
1 mole of AgBr = 1 g atom of Br  
188 g of AgBr = 80 g of Br  
 $\therefore$  188 g of AgBr contain bromine = 80 g

$$0.141 \text{ g of AgBr contain bromine} = \frac{80}{188} \times 0.141$$

This much amount of bromine present in 0.250 g of organic compound

$$\therefore \% \text{ of bromine} = \frac{80}{188} \times \frac{0.141}{0.250} \times 100 = 24\%$$

50. (d)

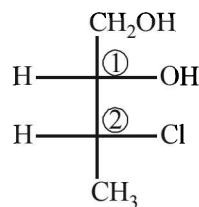

At (1),

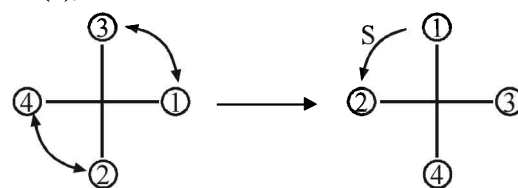

It is 'S' configured

At (2),

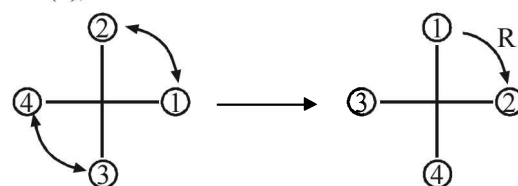

It is 'R' configured.

51. (b) Spent-lye and glycerol are separated by distillation under reduced pressure.

Under the reduced pressure the liquid boil at low temperature and the temperature of decomposition will not reach. e.g. glycerol boils at 290°C with decomposition but at reduced pressure it boils at 180°C without decomposition.



## 10

## Hydrocarbons

**Section-A : JEE Advanced/ IIT-JEE**

- A**
1. ethyne      2. 2-butyne      3.  $C_2H_2$   
 4. ethylene      5.  $H_2SO_4, HgSO_4$       6. less  
 7. 3, 4-dibromo-1-butene-1 (at low temperature) or 1, 4-dibromo-2-butene (at high temperature)
- B**
1. F      2. F
- C**
1. (b)      2. (b)      3. (a)      4. (c)      5. (c)      6. (c)      7. (a)  
 8. (a)      9. (c)      10. (b)      11. (a)      12. (d)      13. (a)      14. (d)  
 15. (a)      16. (c)      17. (b)      18. (b)      19. (a)      20. (b)      21. (d)  
 22. (a)      23. (d)      24. (b)      25. (b)      26. (a)      27. (d)      28. (c)  
 29. (b)      30. (a)      31. (b)
- D**
1. (b)      2. (a, c)      3. (a)      4. (a, b, c, d)      5. (d)      6. (b, d)      7. (b, c, d)
- E**
8.  $C_6H_{12}$   
 10. 55.55 l      11. Butene-2      12. 3-methylpentene-1

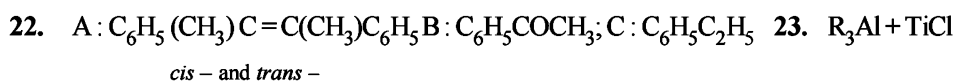
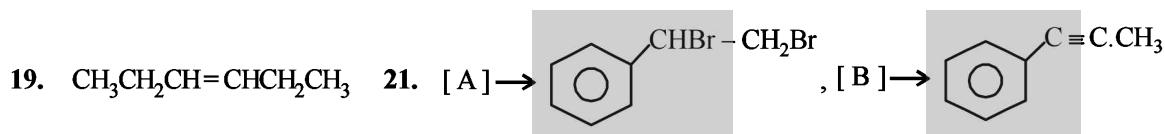
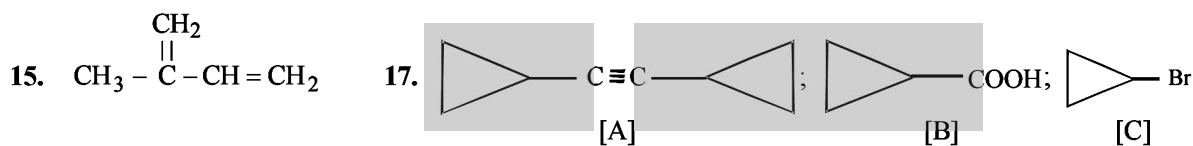
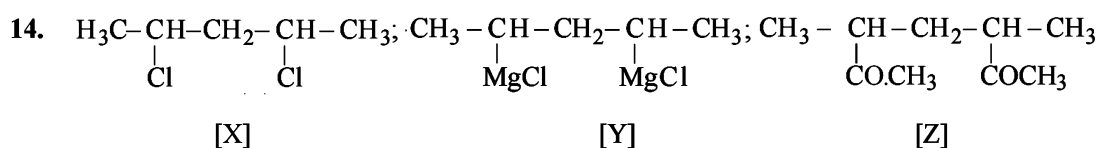

- G**
1. (d)      2. (b)      3. (a)      4. (c)
- H**
1. (a)      2. (c)      3. (b)

**Section-B : JEE Main/ AIEEE**

1. (a)      2. (c)      3. (c)      4. (c)      5. (c)      6. (c)      7. (c)  
 8. (a)      9. (c)      10. (d)      11. (b)      12. (d)      13. (a)      14. (d)  
 15. (b)      16. (d)      17. (c)      18. (b)      19. (b)      20. (b)      21. (d)  
 22. (d)      23. (d)      24. (d)

## Section-A

## JEE Advanced/ IIT-JEE

## A. Fill in the Blanks

1. **Ethyne**, because of the high *s* character of the  $\text{C}\equiv\text{H}$  bond in ethyne (*sp* hybridisation).

2. **2-butyne**

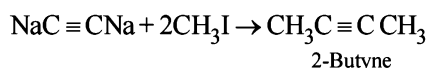
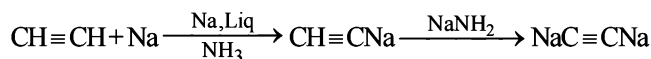

3.  **$\text{C}_2\text{H}_2$**

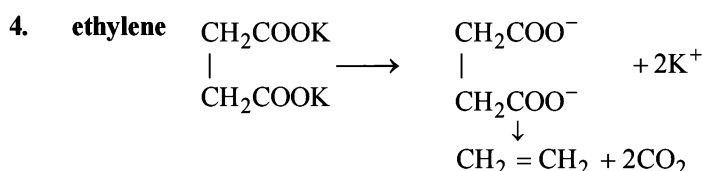

5.  **$\text{H}_2\text{SO}_4$ ,  $\text{HgSO}_4$**

6. **less;**

NOTE:

$$\text{Stability of free radical} \propto \frac{1}{\text{Bond dissociation energy}}$$

Benzyl ( $\text{C}_6\text{H}_5\dot{\text{C}}\text{H}_2$ ) free radical is more stable than methyl ( $\text{CH}_3\dot{\text{C}}$ ) free radical because of hyperconjugation (no bond resonance).

7. **3, 4-dibromo-1-butene** (at low temperature) or **1, 4-dibromo-2-butene** (at high temperature)

## B. True/False

1. **False** : Ethylene reacts with sulphuric acid to form ethyl hydrogen sulphate. It can be dried by passing it through phosphorus pentoxide.

2. **False** : Bromine is less reactive, hence it is more selective and thus  $3^\circ$  hydrogen will be removed more easily than the  $1^\circ$  hydrogen leading to 2-bromo-2-methylpropane as the main product.

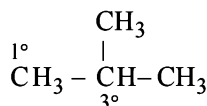

## C. MCQs with One Correct Answer

2. (b) Unsaturated hydrocarbons decolourise alk.  $\text{KMnO}_4$  solution;  $\text{C}_2\text{H}_4$  ( $\text{H}_2\text{C}=\text{CH}_2$ ) is an alkene.

3. (a) In a homologous series, higher the number of C-atoms, higher is the b.p.

4. (c) Four isomers

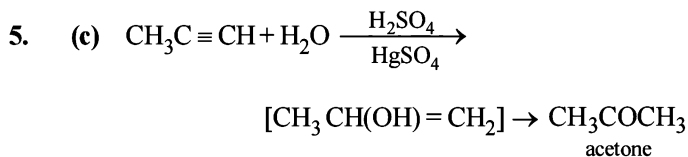
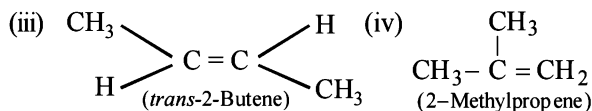
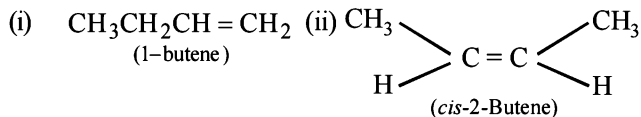

6. (c)  $\text{CH}_2 = \text{CH}_2 + \text{H}_2\text{SO}_4 \rightarrow \text{CH}_3\text{CH}_2\text{OSO}_3\text{H}$

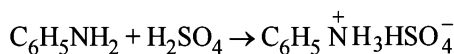
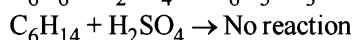
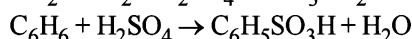

Only hexane does not dissolve in conc.  $\text{H}_2\text{SO}_4$  even on warming.

8. (a) Acidic hydrogen is present in alkynes, attached to the triply bonded C-atoms. They can be easily removed by means of a strong base.

9. (c) **TIPS/Formulae :**

*Anti*-Markovnikoff's addition of HBr is observed only with unsymmetrical alkenes, *a*, *b*, and *d*.

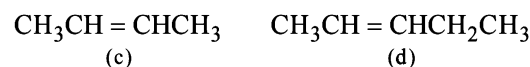
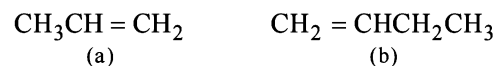

10. (b) For isomeric alkanes, the one having longest straight chain has highest b.p. because of larger surface area.

11. (a) Ethylene has restricted rotation [due to  $\text{C}=\text{C}$ ], acetylene no rotation [due to  $\text{C}\equiv\text{C}$ ], hexachloroethane has more rotation than ethylene but less than ethane because of greater size of the substituent (chlorine) than in ethane (substituent is hydrogen).

13. (a) **TIPS/Formulae :**

Hydration of alkynes via mercuration takes place in accordance with Markovnikov's manner rule

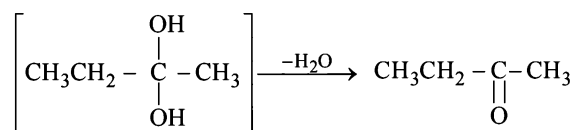
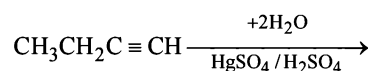

14. (d) In propyne ( $\text{CH}_3\text{C}\equiv\text{CH}$ ), the terminal hydrogen is acidic and reacts with ammoniacal  $\text{AgNO}_3$ .

15. (a) **TIPS/Formulae :**

The relative rates of hydrogenation decreases with increase of steric hinderance.

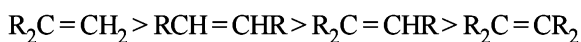

Among the four olefins, (a) and (b) are less stable (Saytzeff rule). Further in (a), the bulky alkyl groups are on same side (*cis*-isomer), hence it is less stable.

16. (c) **TIPS/Formulae :**

Peroxide effect is effective only in case of HBr and not in case of HCl and HI.

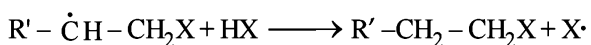
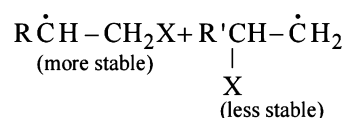
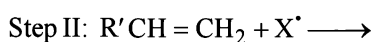
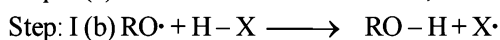
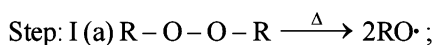

For HCl, Step-I (b) is endothermic while step-II is exothermic but for HI, Step-I(b) is exothermic while Step-II is endothermic.

17. (b) **TIPS/Formulae :**

Addition on triple bond takes place by the *syn*-addition of hydrogen.

Since the configuration of the double bond already present is *cis*, the compound formed will have a plane of symmetry and hence optically inactive.

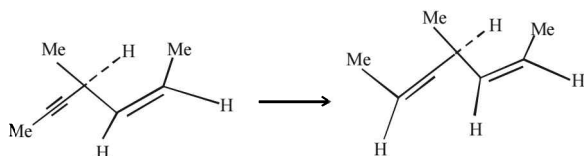

18. (b) **TIPS/Formulae :**

Alkenes undergo electrophilic addition reactions. HOCl undergoes self-ionization

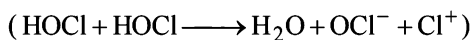

to give  $\text{H}_2\text{O}^+ + \text{OCl}^- + \text{Cl}^+$ .

So, it is the  $\text{Cl}^+$  that attacks in the first step.

19. (a) **TIPS/Formulae :**

The  $\pi$  bond is formed by the sideways overlapping of two *p*-orbitals of the two carbon atoms.

The molecular plane does not have any  $\pi$  electron density as the *p*-orbitals are perpendicular to the plane containing the ethene molecule. The nodal plane in the  $\pi$ -bond of ethene is located in the molecular plane.

20. (b)  $\text{Br}\cdot$  is less reactive and more selective and so the most stable free radical ( $3^\circ$ ) will be the major product.

21. (d) **TIPS/Formulae :**

In 1-butyne terminal hydrogen is acidic where as in 2-butyne there is no terminal hydrogen. Thus 2-butyne will not react with ammoniacal  $\text{Cu}_2\text{Cl}_2$ . While 1-butyne, being terminal alkyne, will give red ppt. with ammoniacal cuprous chloride

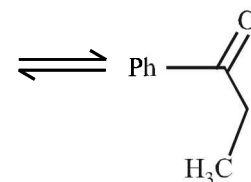
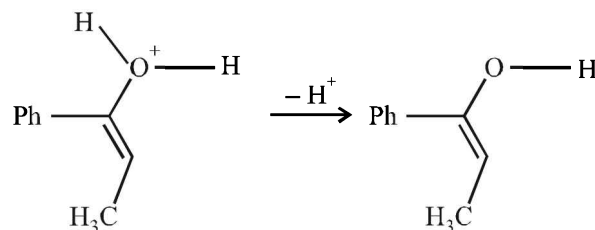
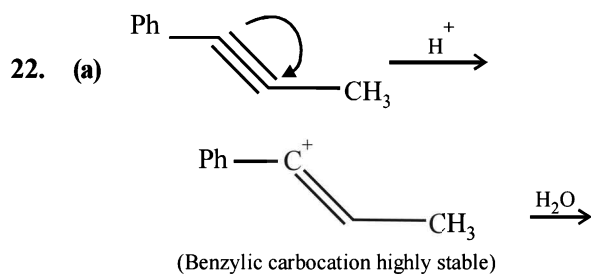

23. (d)  $\text{H}_2/\text{Pd}/\text{BaSO}_4$  reduces an alkyne to *cis*-alkene,  $\text{H}_2/\text{Pt}$  reduces it to alkane,  $\text{NaBH}_4$  does not reduce an alkyne. Reduction of an alkyne by active metal in liq.  $\text{NH}_3$  gives *trans*-alkene.

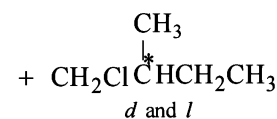
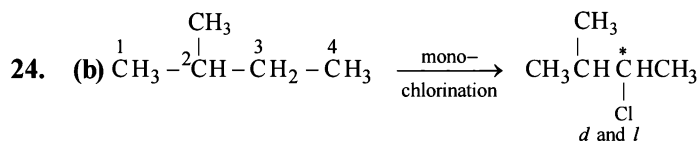

(i) Chlorination at C-2 and C-4 produces no chiral compounds

(ii) Chlorination at C-3 produces a chiral carbon marked with star (*d* and *l* form).

(iii) Chlorination at C-1 also produces a chiral carbon marked with star (*d* and *l* form).

25. (b) Nitrosyl chloride adds on olefins according to Markovnikof's rule, where  $\text{NO}^+$  constitutes the positive part of the addendum.

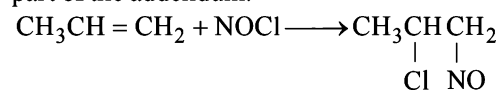

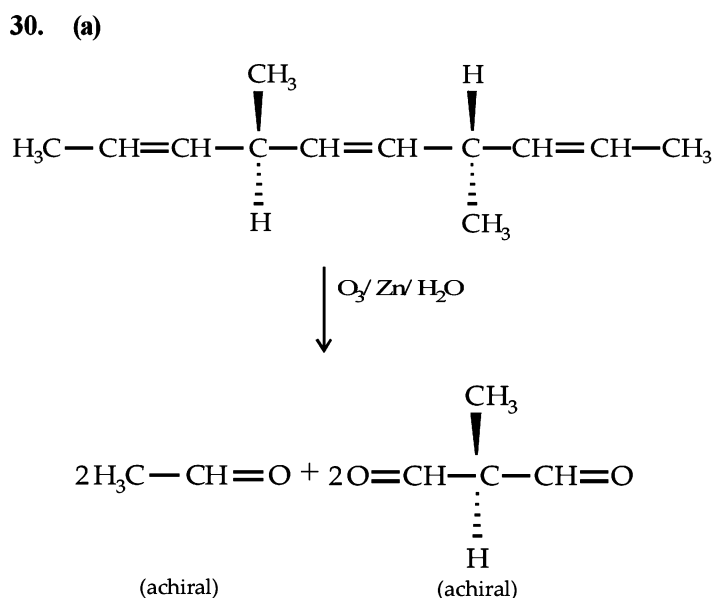
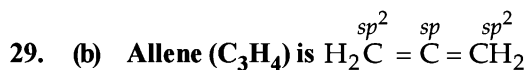
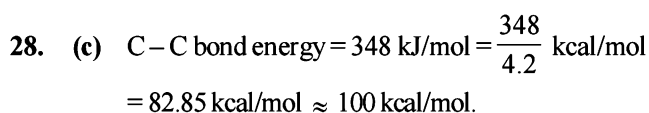
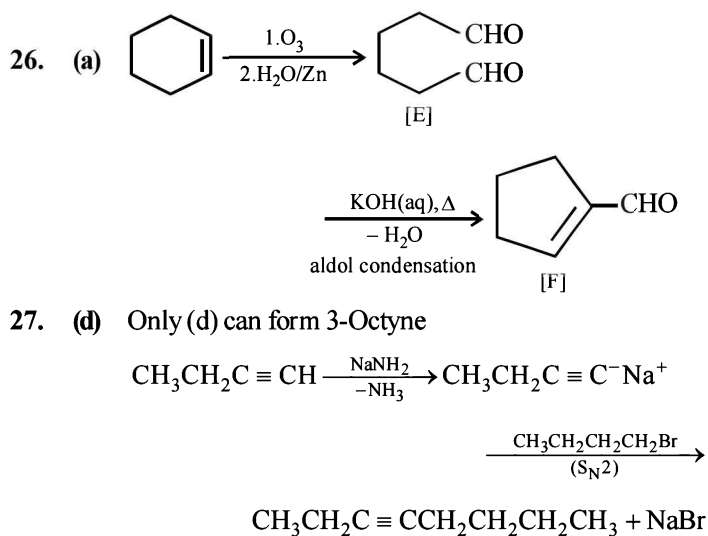

2. (a, c) Hyperconjugation in toluene activates the benzene ring for electrophilic substitution.

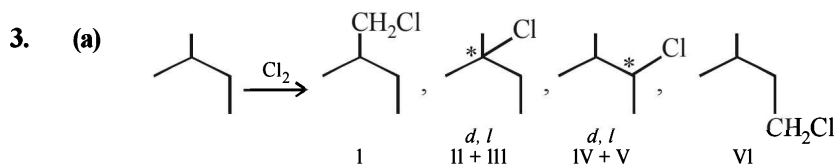

So, the value of N will be  $1 + 2 + 2 + 1 = 6$ .

Since enantiomers have nearly same physical properties, II and III as well as IV and V can't be separated, hence the number of isomers (M) will be

$$1 + 1 + 1 + 1 = 4.$$

31. (b) Greater the extent of branching, lesser is the boiling point of the hydrocarbon, so order of b.p is III > II > I.

#### D. MCQs with One or More Than One Correct

1. (b) TIPS/Formulae :

Heat of hydrogenation is related to stability of molecules; higher the stability, lower is the heat of hydrogenation.

Butadiene,  $\text{CH}_2 = \text{CHCH} = \text{CH}_2$  has two double bonds so its heat of hydrogenation will be more than the other three.

Alkenes follow the following order of stability

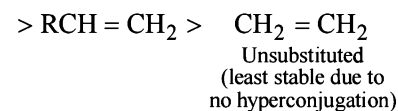
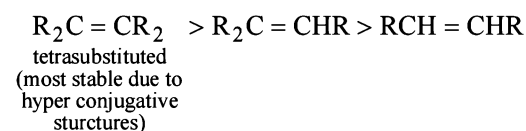

Thus here stability order of the given monoalkenes is

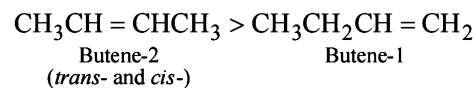

**NOTE :** The *trans*-2-butene is more stable than the *cis*-because in the *cis*-isomer the two bulky groups are crowded together with the result it has more van der Waal's strain than the *trans*-isomer.

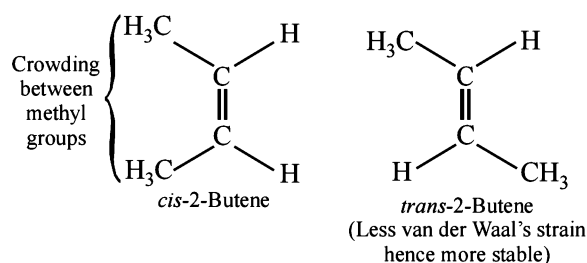

## 4. (a, b, c, d)

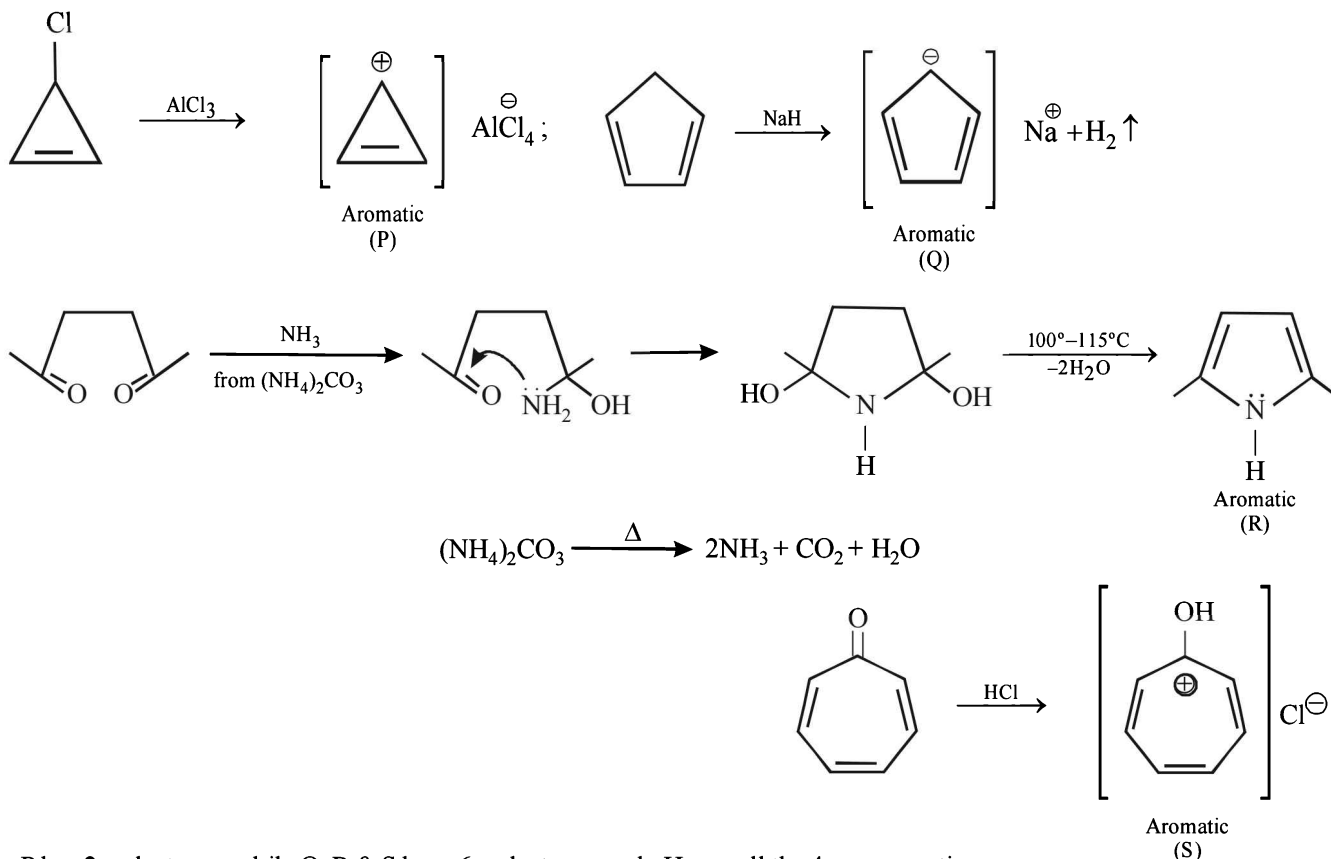

**Note :** P has 2  $\pi$  electrons, while Q, R & S have 6  $\pi$  electrons each. Hence all the 4 are aromatic.

## 5. (d)

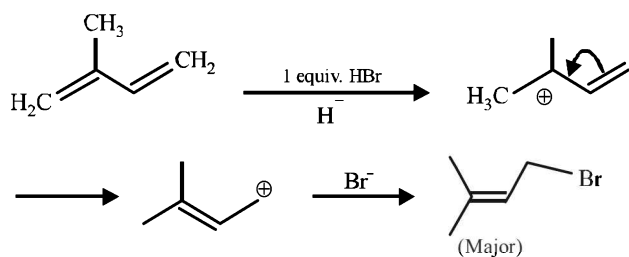

## 6. (b, d)

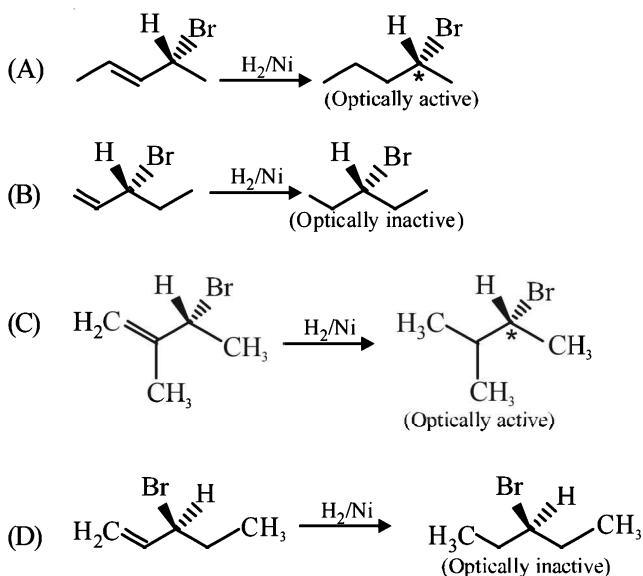

## 7. (b, c, d)

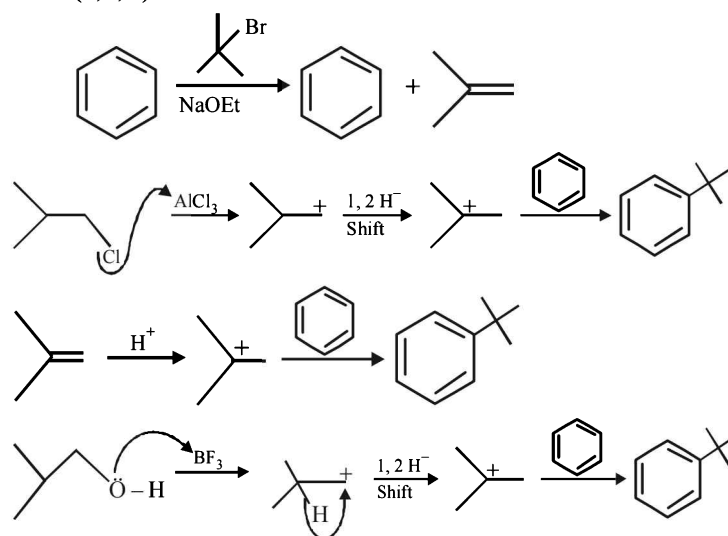

## E. Subjective Problems

1. Bromine water test :  $\text{C}_2\text{H}_2$  decolourises bromine water while  $\text{CH}_4$  does not decolourises bromine water.

2. (i)  $\text{CH} \equiv \text{CH} \xrightarrow{\text{hydration}} \text{CH}_3\text{CHO} \xrightarrow{\text{OH}^-} \text{aldol cond.}$   
ethyne

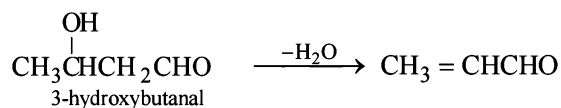

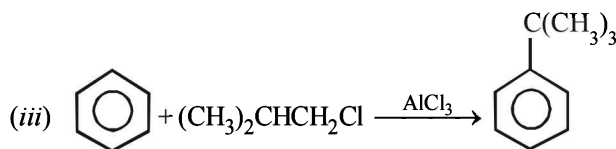
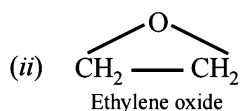

**NOTE :** that the  $1^\circ$  carbocation,  $(\text{CH}_3)_2\text{CHCH}_2^+$  formed during reaction rearranges to the more stable,  $3^\circ$  carbocation,  $(\text{CH}_3)_3\text{C}^+$  and hence the above product is formed.] (see also *ix* part)

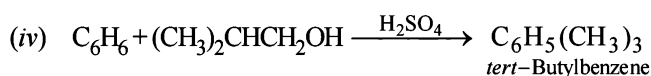

**Explanation :**

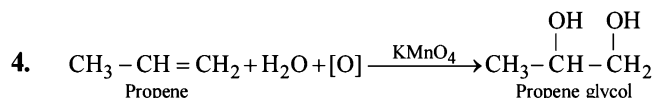
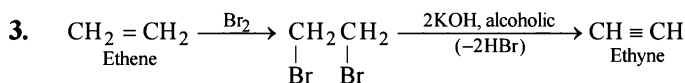
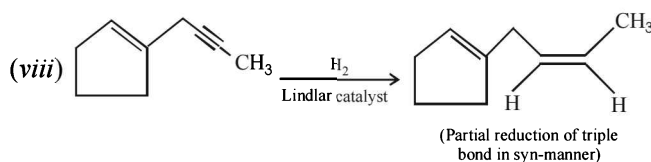
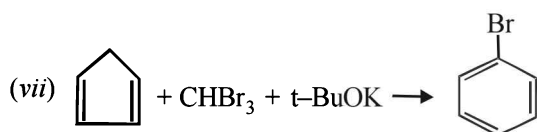
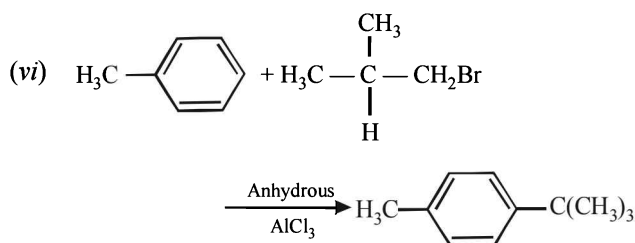
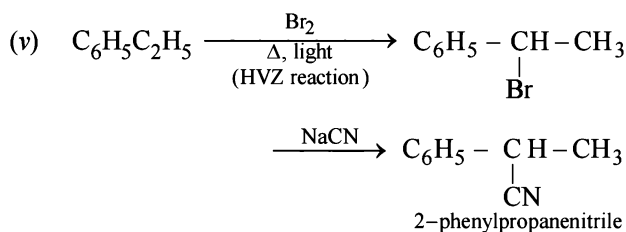
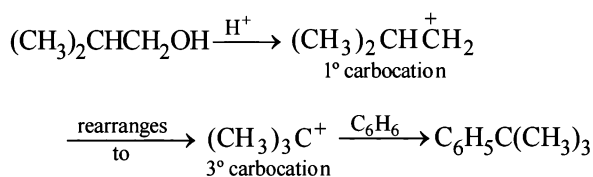

[NOTE : Colour of  $\text{KMnO}_4$  is discharged]

5. (i) **TIPS/Formulae :**  
Chlorination of methane is a free radical substitution reaction.

In dark, chlorine is unable to be converted into free radicals, hence the reaction does not occur.

(ii) **TIPS/Formulae :**

Addition of unsymmetrical addendum (HBr in present case) to unsymmetrical olefin ( $\text{CH}_3\text{CH}=\text{CH}_2$ , in present case) takes place according to Markownikoff rule.

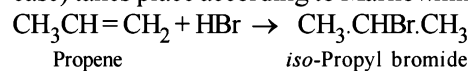

(iii) Unlike olefins,  $\pi$ -electrons of benzene are delocalised (resonance) and hence these are unreactive towards addition reactions. Moreover, addition reaction leads to destruction of the benzenoid ring.

(iv) In presence of light, toluene undergoes *side chain bromination* through a free radical mechanism.

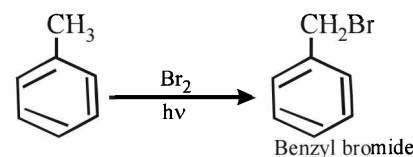

In presence of  $\text{FeBr}_3$ , toluene undergoes *electrophilic substitution* in the benzene ring.

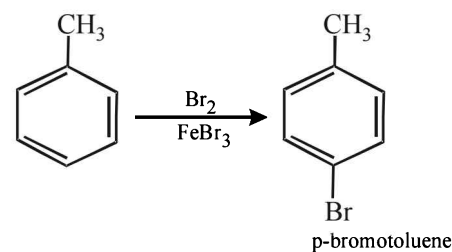

[NOTE :  $-\text{CH}_3$  is *o*-, *p*-directing]

(v) **TIPS/Formulae :**

1, 3-Butadiene is a conjugated diene and is a resonance hybrid:

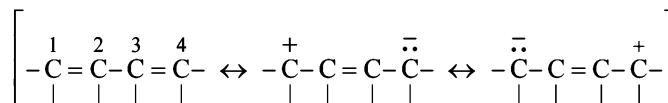

Thus resonance induces some double bond character in the central C-C bond leading to the shortening of this bond. **Alternatively**, all the four C atoms of 1, 3-butadiene are  $sp^2$  hybridised and thus their C-C bond length will be lower than that of n-butane in which all the four C atoms are  $sp^3$  hybridised.

(vi) *tert*-Butylbenzene does not give benzoic acid on treatment with acidic  $\text{KMnO}_4$  because it does not contain any hydrogen atom on the key carbon atom.

(vii) Reduction of central ring to form A involves reduction of all the three cyclobutadiene rings (which are

antiaromatic as they have  $4\pi$  electrons each), i.e. antiaromatic rings are converted into nonaromatic rings. On the other hand, reduction of the terminal ring to form B involves reduction of only one antiaromatic ring. Remember that antiaromatic rings impart instability.

6. (i) **NOTE :** Under normal conditions, *ter*-butyl bromide is formed, isobutyl bromide is formed in presence of peroxide.

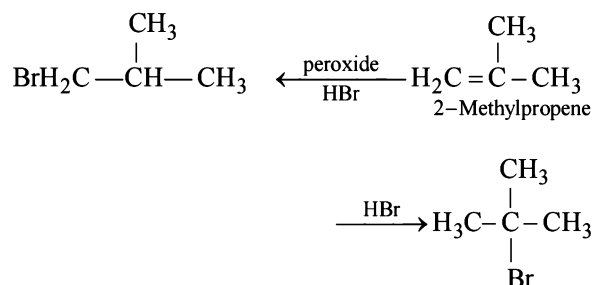

- (ii) Ethyne ( $\text{HC} \equiv \text{CH}$ ) and only those derivatives which have at least one acetylenic hydrogen atom ( $\equiv \text{C}-\text{H}$ ) i.e. terminal alkynes will give white precipitate with ammonical silver nitrate solution.

7.  $[\text{C}_2\text{H}_5\text{OH} + \text{PCl}_5 \longrightarrow \text{C}_2\text{H}_5\text{Cl}]$

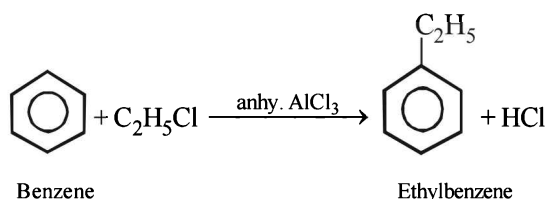

8. **Calculation of molecular formula of A.**

Element	Percentage	Relative No. of atoms	Simplest whole ratio
C	85.7	$85.7/12 = 7.14$	$7.14/7.14 = 1$
H	14.3	$14.3/1 = 14.3$	$14.3/7.14 = 2$

$\therefore$  Empirical formula of A =  $\text{CH}_2$

Determination of molecular weight of A

1 g of A consumes = 38.05 g of 5%  $\text{Br}_2$  (in  $\text{CCl}_4$ )

$$= \frac{38.05 \times 5}{100} \text{ g of } 100\% \text{ Br}_2$$

$$= 1.90 \text{ g of } 100\% \text{ Br}_2.$$

Now since 1.90 g of  $\text{Br}_2$  is consumed by 1 g of compound A

$\therefore$  160 g (1 mole) of  $\text{Br}_2$  will be consumed by

$$= \frac{1}{1.90} \times 160 = 84.2 \text{ g of A} = 84.0 \text{ (app.) g of A}$$

$\therefore$  Molecular weight of A = **84**

$$\text{Hence, } n = \frac{84}{12 + 2} = 6$$

$\therefore$  Molecular formula of A =  $(\text{CH}_2)_6 = \text{C}_6\text{H}_{12}$

Since the hydrocarbon A consumes 1 molar equivalent of hydrogen, it must contain one double bond. Oxidation of compound A with  $\text{KMnO}_4$  to form compound C ( $\text{C}_4\text{H}_8\text{O}$ ) and acetic acid indicates  $=\text{CH}\cdot\text{CH}_3$  fragment in A, i.e.

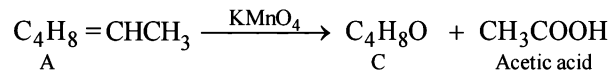

Now the fragment  $\text{C}_4\text{H}_8$  of A on oxidation forms the compound 'C' ( $\text{C}_4\text{H}_8\text{O}$ ) which may be easily obtained from butyne-2 and acidic aq.  $\text{HgSO}_4$ , the compound 'C' must be ethylmethyl ketone.

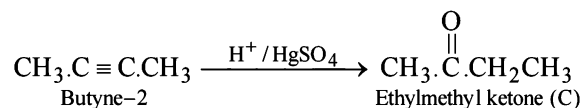

The formation of ketone 'C' from  $\text{C}_4\text{H}_8$  fragment of 'A' can be explained by the following structure of A.

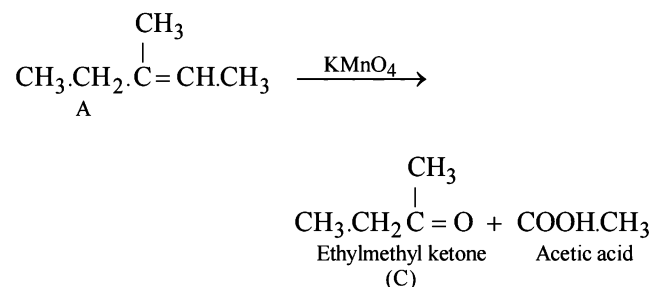

Hence formation of 'B' can be represented as below.

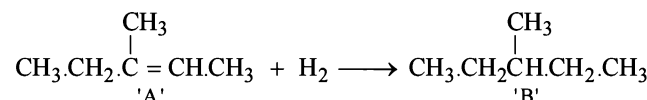

9. (i) By amm.  $\text{AgNO}_3$  or by acidic-H tests : Terminal alkynes give white precipitate with amm.  $\text{AgNO}_3$  or red ppt. with amm.  $\text{Cu}_2\text{Cl}_2$  (H atom attached on *sp* hybridized carbon is acidic).

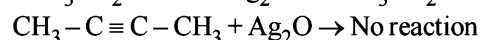
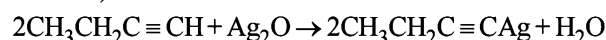

**NOTE :** Only terminal alkynes respond to these reactions.

- (ii) Cyclohexene gives positive response to *bromine water test* and *Baeyer's test* while cyclohexane does not respond to these reagents.

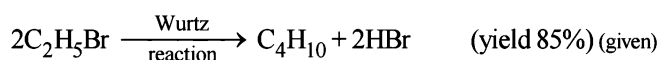
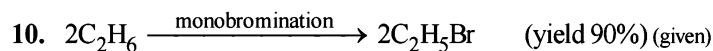

Moles of *n*-butane to be produced

$$= \frac{55 \text{ g}}{58 \text{ g mol}^{-1}} = 0.948 \text{ mol} \quad (\because \text{molecular mass of } \text{C}_4\text{H}_{10} = 58)$$

Amount of  $\text{C}_2\text{H}_5\text{Br}$  required to obtain 0.948 mol. of  $\text{C}_4\text{H}_{10}$  =  $2 \times 0.948 \text{ mol}$ .

Hence, the amount of  $C_2H_5Br$  required

$$= \frac{2 \times 0.948 \times 100}{85} \text{ mol.} \quad \dots(1) \quad [\because \text{yield is 85\% only}]$$

Further 1 mole of  $C_2H_6$  gives one mole of  $C_2H_5Br$ , hence number of moles of  $C_2H_6$  reqd. for  $C_2H_5Br$  in (1)

$$= \frac{2 \times 0.948 \times 100 \times 100}{85 \times 90} \text{ mol.} = 2.48 \text{ mol} \quad [\because \text{yield is 90\%}]$$

$\therefore$  Required volume of ethane at NTP

$$= 22400 \times 2.48 = 55552 \text{ ml.} = \mathbf{55.55 \text{ litres}}$$

### 11. TIPS/Formulae :

A symmetric alkene does not follow Markovnikoff and *anti*-Markovnikoff's rule (Peroxide effect).

B has to be a symmetric alkene (**butene-2**)

$CH_3CH=CHCH_3$  as it will give the same product

$CH_3-CH(Br)-CH_2-CH_3$  in presence /absence of peroxide.

12. An optically active hydrocarbon will have an asymmetric C-atom. This means  $D(C_6H_{12})$  should have an asymmetric C-atom &  $C_6H_{14}$  will have **no** asymmetric C-atom, hence D would be **3-methylpentene-1**,

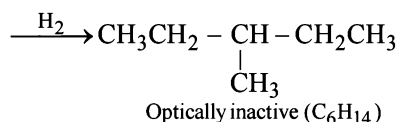
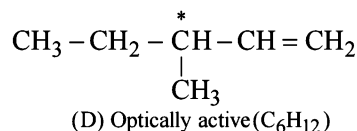

13. (i)  $S_N2$  reaction leads to inversion in configuration.

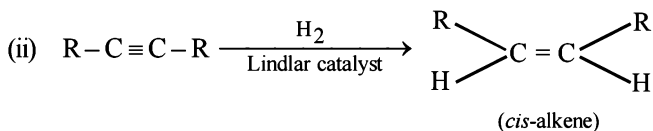
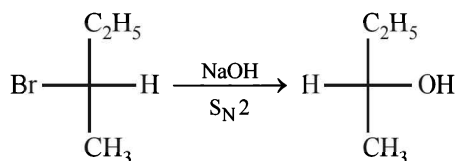

### NOTE:

- (i) **Lindlar's catalyst** is Pd supported over  $CaCO_3$  which is partially poisoned by  $(CH_3COO)_2Pb$ . It can restrict the hydrogenation of alkyne to alkene stage. It yields a *cis*-alkene.
- (ii) Reduction of alkynes to alkene stage can also be carried out with sodium or lithium in liquid  $NH_3$ . Here *trans*-alkene is major product.
14. **TIPS/Formulae :**

- (i) 1, 4-Pentadiene reacts with HCl in presence of benzoyl peroxide in Markovnikoff's way.

**NOTE :** Peroxide effect applies to HBr only.

- (ii) Grignard reagent reacts with ethyl acetate to form ketones, or *ter*-alcohol if Grignard reagent is taken in excess.

Thus the given reactions can be written as below.

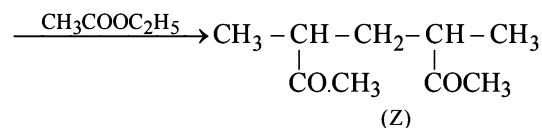
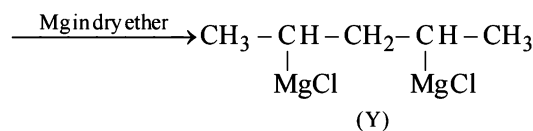
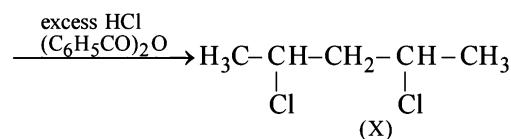

### 15. Summary of the given reactions

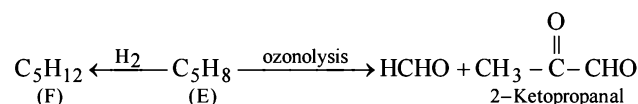

Since hydrogenation of (E) to (F) takes up two molecules of hydrogen, it indicates the presence of two double bonds in E which is further supported by its ozonolysis to form two products having three carbonyl groups. Further structure of ozonolysis product leads to following structure to compound (E).

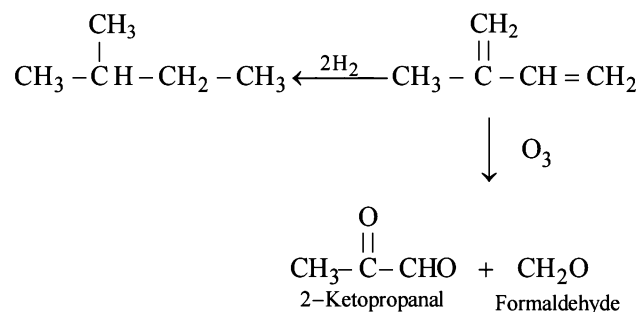

### 16. TIPS/Formulae :

In  $S_N1$  reaction racemization as well as inversion is observed. Reaction of optically active 2-iodobutane with NaI in acetone is an  $S_N1$  reaction which involves formation of carbocation as intermediate.

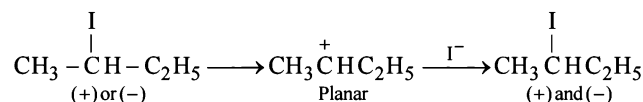

Thus the product, being a racemic mixture will be optically inactive.

### 17. Summary of the given facts

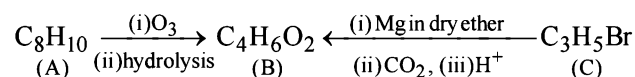

Since compound (B) is obtained from compound (C)  $C_3H_5Br$  through reaction with Mg and  $CO_2$ , it seems that compound



(B) is a carboxylic acid formed via the formation of Grignard reagent. Hence compound (C) should be an alkyl halide having three carbon atoms. The alkyl halide (C) is unsaturated (indicated by number of hydrogen atoms) which is present in the form of ring and thus (C) should be bromocyclopropane.

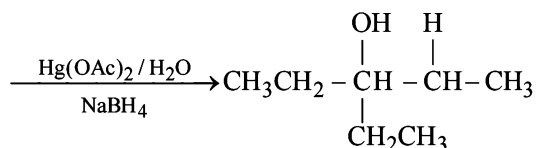
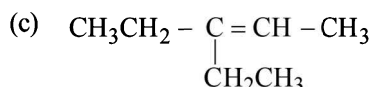
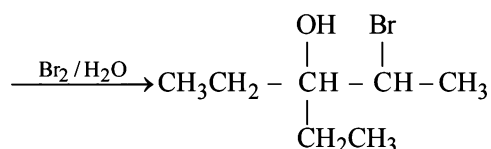
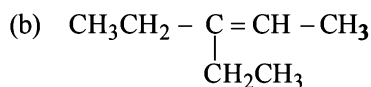
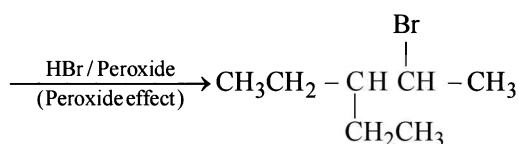
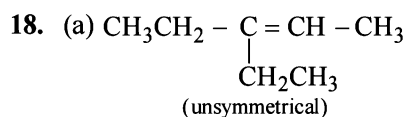
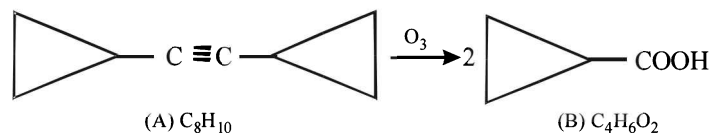
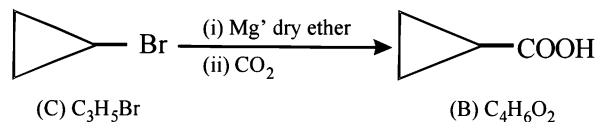

### 19. TIPS/Formulae :

- It should be an alkene as it adds one mole of  $\text{H}_2$ .
- The  $\text{C}_6$  alkene should be symmetrical because on oxidation it gives a single carboxylic acid having three carbon atoms.

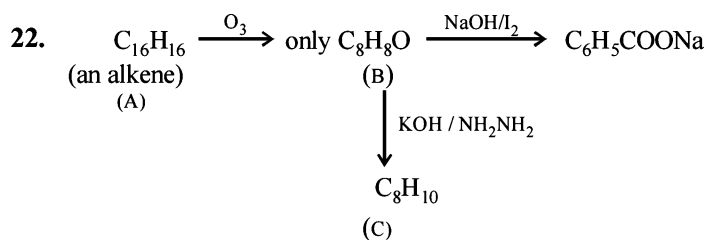
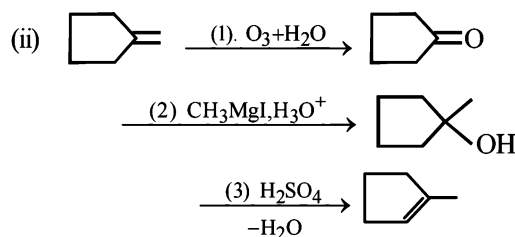
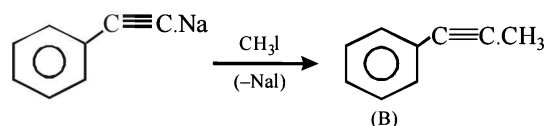
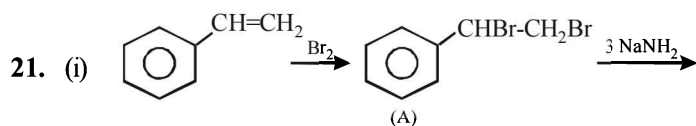
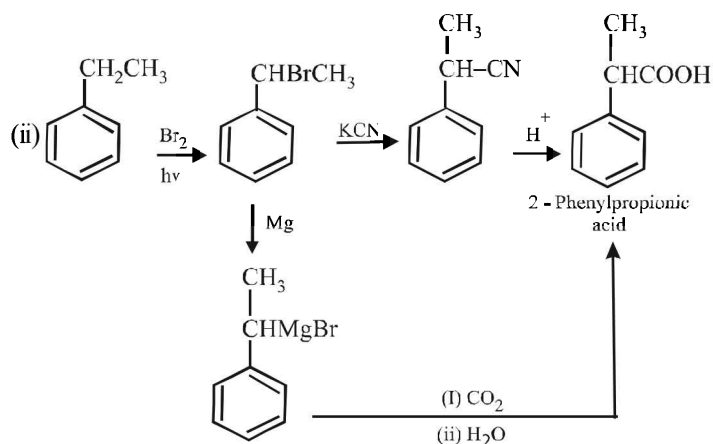
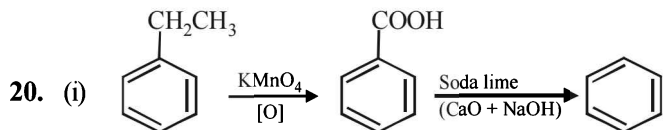
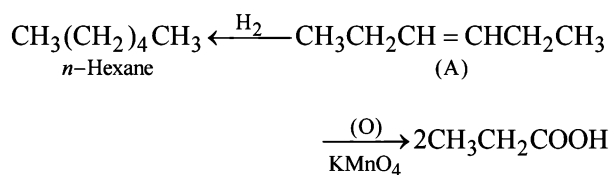

- Conversion of (B) to (C) involves iodoform reaction, hence (B) must contain  $-\text{COCH}_3$  group leading to  $\text{C}_6\text{H}_5\text{COCH}_3$  ( $\text{C}_8\text{H}_8\text{O}$ ) as its molecular formula.
- Since the given alkene gives only one product on ozonolysis, so the given alkene must be a symmetrical alkene containing a double bond in centre. Thus the alkene (A) must have following structure

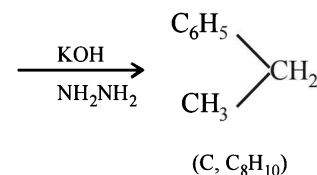
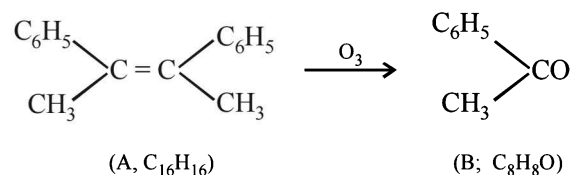

Isomeric structures of A

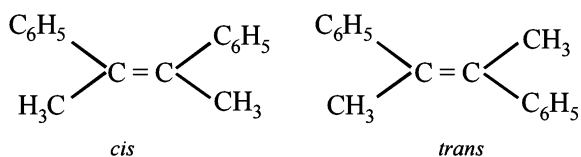

**NOTE :** Since catalytic hydrogenation of alkenes takes place in *cis*-(*syn*-) manner; hence racemic mixture will be formed by the *trans*-isomer.

23. Ziegler – Natta catalyst ( $\text{R}_3\text{Al} + \text{TiCl}_4$ )

24. (i) Formation of  $\text{HCOONa}$  and a primary alcohol due to **Cannizzaro reaction** of F and G indicate that either F or G should be  $\text{HCHO}$ . Thus the alkene A should have  $\text{CH}_2 =$  grouping. The remaining 5 C's of A should have grouping =  $\text{HCC}_4\text{H}_9$ .

(ii) Formation of only E by the ozonolysis of D ( $\text{C}_6\text{H}_{12}$ ) indicates that D should have following structure

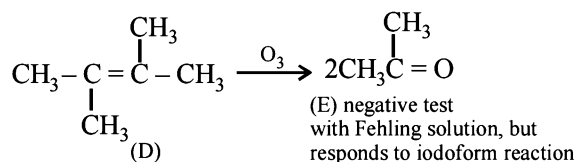

**NOTE :** Fehling's test is given by aldehydes and not ketones.

(iii) Since A is isomer of D, former should have following structure.

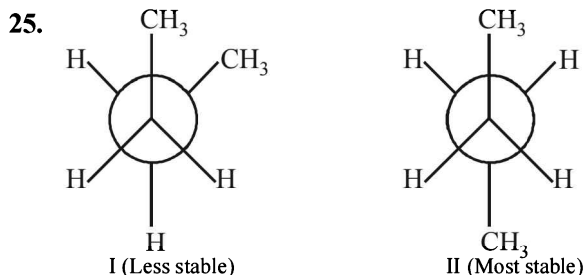
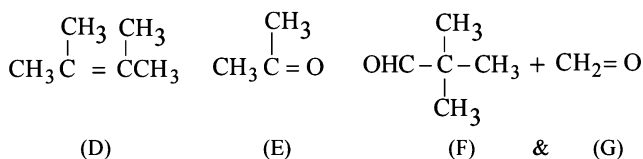
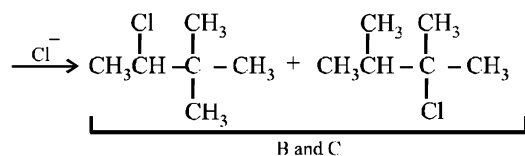
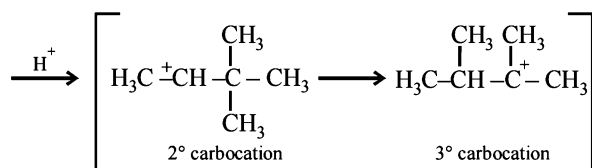
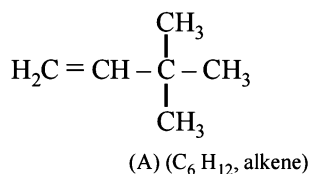

Staggered conformations of n-butane

Newmann projection formulae II is the most stable because the bulky groups ( $\text{CH}_3$ ) are at maximum possible distance from each other. Structure I is relatively less stable because the two  $\text{CH}_3$  groups are close to each other leading to vander Waal's repulsion between the two methyl groups.

### G. Comprehension Based Questions

1. (d)      2. (b)

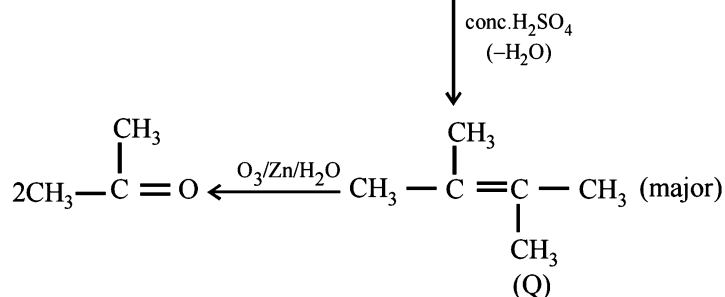
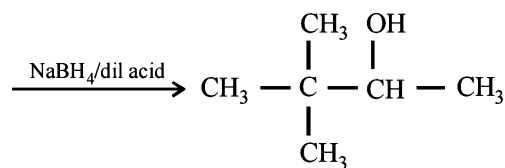
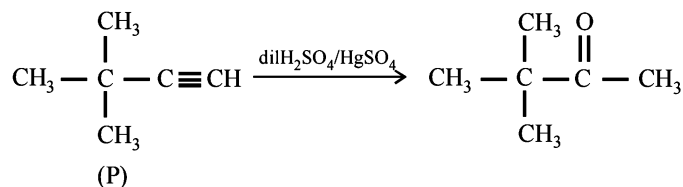

3. (a)

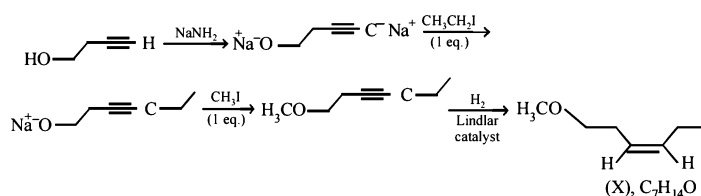

4. (c)

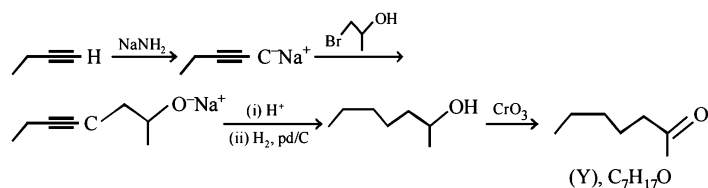

### H. Assertion & Reason Type Questions

1. (a)  $\text{CH}_3\text{CH}_2 - \text{CH} = \text{CH}_2 + \text{Br}_2 \longrightarrow \text{CH}_3\text{CH}_2\overset{*}{\text{C}}\text{HCH}_2\text{Br}$

|  
Br

2. (c) **TIPS/Formulæ :**

In presence of peroxide, addition of  $\text{HBr}$  on alkenes takes place via free radicals

Here assertion is correct but reasoning is incorrect. Here two free radical are formed,  $2^\circ$  free radical, being more stable, governs the product.

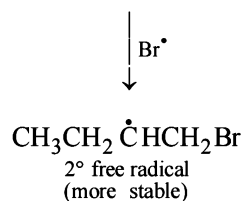
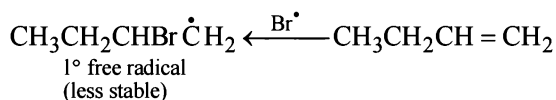

## 3. (b) TIPS/Formulae :

With *trans*-2-butene, the product of Br<sub>2</sub> addition is optically inactive.

Even though, both assertion and reason are correct. the correct reason for the formation of *meso*-2,3-dibromobutane from *trans*-2-butene is *anti* addition of Br<sub>2</sub>.

## Section-B JEE Main/ AIEEE

1. (a) Acetylene reacts with the other three as:

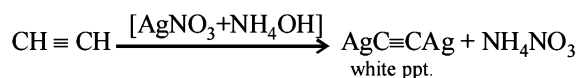
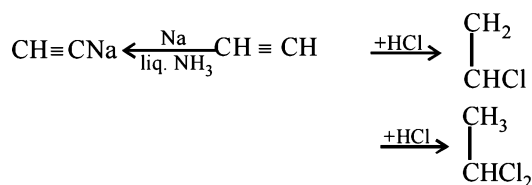

2. (c)
- $\text{CH}\equiv\text{CH} + \text{HOCl} \longrightarrow \begin{array}{c} \text{CHOH} \\ || \\ \text{CHCl} \end{array}$

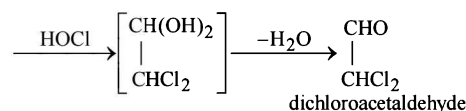

3. (c) In neopentane all the H atoms are same (1°).

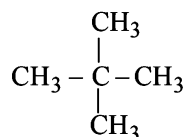

4. (c)
- $\text{CH}_3 - \overset{\text{CH}_3}{\text{CH}} - \text{CH}_2 - \text{CH}_3 \xrightarrow[\text{sunlight}]{\text{Br}_2} \text{CH}_3 - \overset{\text{CH}_3}{\underset{\text{Br}}{\text{C}}} - \text{CH}_2\text{CH}_3$
- 
- 2-bromo-2-methyl butane

Ease of replacement of H-atom 3° > 2° > 1°.

5. (c) Alkenes combine with hydrogen under pressure and in presence of a catalyst (Ni, Pt or Pd) and form alkanes.

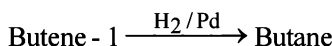

6. (c)
- $\text{CH}_2 = \text{CH} - \text{CH} = \text{CH}_2 + \text{HBr} \longrightarrow \text{CH}_2 = \text{CH} - \overset{\text{Br}}{\text{CH}} - \text{CH}_3$
- 
- At -80°C the product is 1, 2-addition
- 
- $\text{CH}_2 - \overset{\text{Br}}{\text{CH}} = \text{CH} - \text{CH}_3$
- 
- At 40°C the product is 1, 4-addition

7. (c)
- $\text{CH}_3 - \overset{\text{CH}_3}{\text{CH}} - \overset{\text{CH}_3}{\text{CH}} - \text{CH}_3$
- . Since it contains only two types of H-atoms hence it will give only two mono chlorinated compounds viz.
- $\text{Cl} \cdot \text{CH}_2 - \overset{\text{CH}_3}{\text{CH}} - \overset{\text{CH}_3}{\text{CH}} - \text{CH}_3$
- 
- 1-chloro-2,3-dimethyl butane

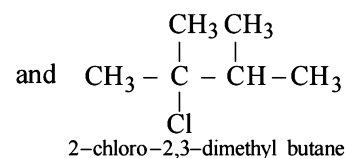

8. (a) Water adds directly to the more reactive alkene in presence of a strongly acidic catalyst forming alcohols. Addition occurs according to Markonikov's rule.

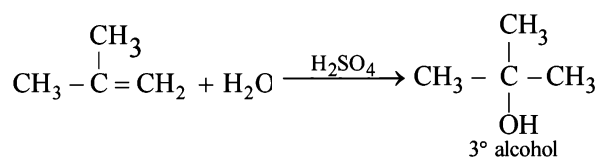
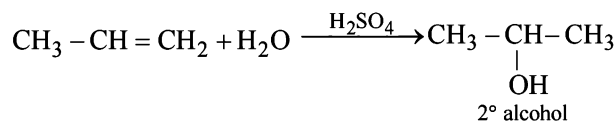

NOTE : Addition follows Markownikoff's rule.

9. (c)
- $\text{CH}_3 - \overset{\text{Cl}}{\text{C}} - \overset{\text{Cl}}{\text{C}} - \text{CH}_3$
- . 2, 3-dichloro butane will exhibit optical isomerism due to the presence of two asymmetric carbon atom.

10. (d) When alkyl benzene are oxidised with alkaline KMnO
- <sub>4</sub>
- , (strong oxidising agent) the entire alkyl group is oxidised to -COOH group regardless of length of side chain.

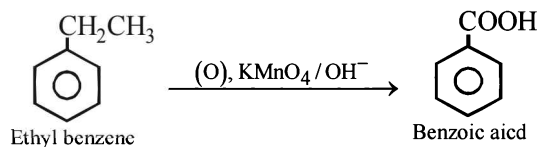

11. (b) The reaction follows Markownikoff rule which states that when unsymmetrical reagent adds across unsymmetrical double or triple bond the negative part adds to carbon atom having lesser number of hydrogen atoms.

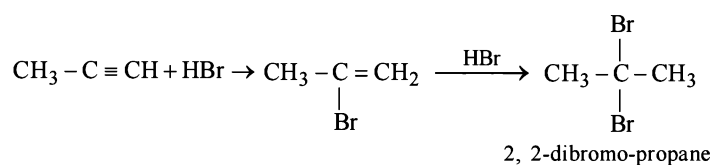

12. (d)  $\text{FeCl}_3$  is Lewis acid. In presence of  $\text{FeCl}_3$  side chain hydrogen atoms of toluene are substituted.

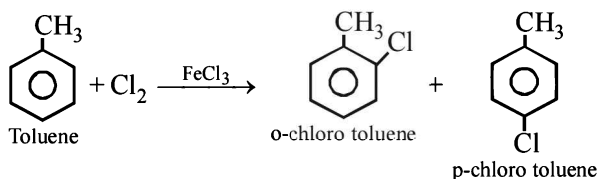

13. (a) NOTE : Toluene ( ) contains  $-\text{CH}_3$  group which

is *o*-, *p*- directing group so on nitration of toluene the  $-\text{NO}_2$  group will occupy *o*-, *p*- positions.

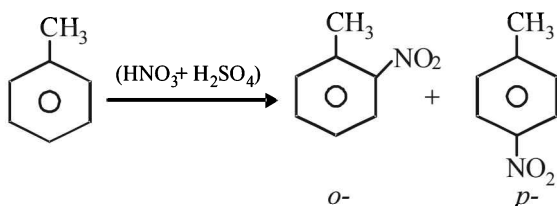

on reduction with  $\text{Sn}/\text{HCl}$  they will form corresponding anilines in which  $-\text{NO}_2$  group changes to  $-\text{NH}_2$ . The

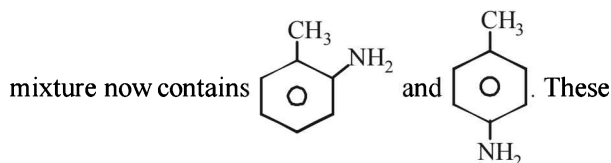

anilines when diazotized and then treated with  $\text{CuBr}$  forms *o*-, *p*- bromotoluenes.

14. (d) Completing the sequence of given reactions,

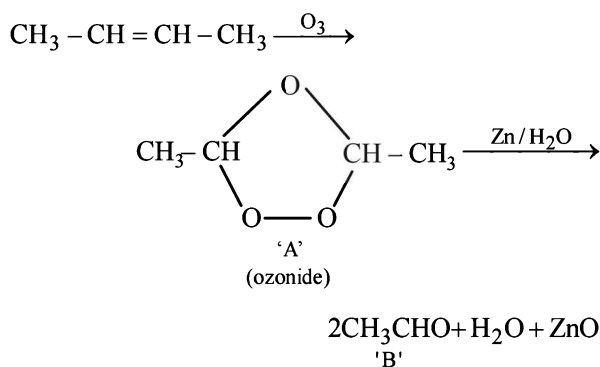

Thus 'B' is  $\text{CH}_3\text{CHO}$

Hence (d) is correct answer.

15. (b) Alkynes having terminal  $-\text{C} \equiv \text{H}$  react with Na in liquid ammonia to yield  $\text{H}_2$  gas of the given compounds  $\text{CH}_3\text{CH}_2\text{C} \equiv \text{CH}$  can react with Na in liquid  $\text{NH}_3$  so the correct answer is (b).

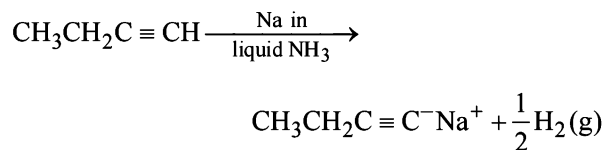

16. (d) Writing the reaction we get

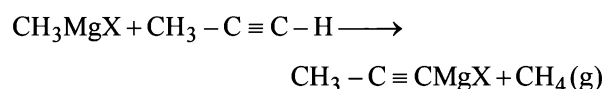

So we find that  $\text{CH}_4$  is produced in this reaction.

17. (c) The given molecular formula suggests that the aldehyde formed will be acetaldehyde hence the alkene will be

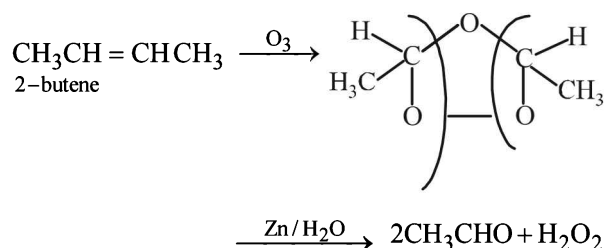

18. (b) Compound must contain a vinyl group ( $-\text{C} = \text{CH}_2$ ) in order to give formaldehyde as one of the product.

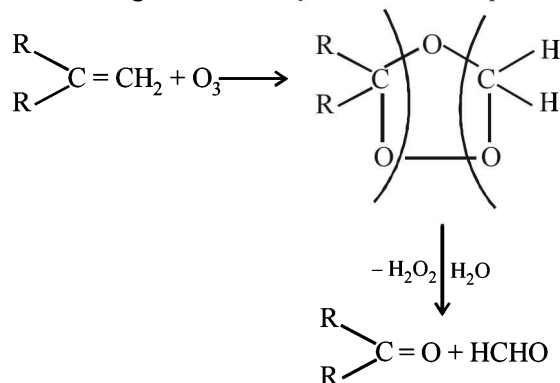

19. (b)  $\xrightarrow[\text{monohalogenation}]{\text{Cl}_2/h\nu}$  single product
- neopentane

20. (b) Anti addition of hydrogen atoms to the triple bond occurs when alkynes are reduced with sodium (or lithium) metal in ammonia, ethylamine, or alcohol at low temperatures. This reaction called, a dissolving metal reduction, produces an (E)- or *trans*-alkene. Sodium in liq.  $\text{NH}_3$  is used as a source of electrons in the reduction of an alkyne to a *trans* alkene.

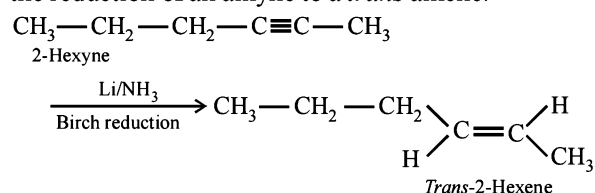

21. (d) When 1, 3-dimethylcyclopentene is heated with ozone and then with zinc and acetic acid, oxidative cleavage leads to keto - aldehyde.

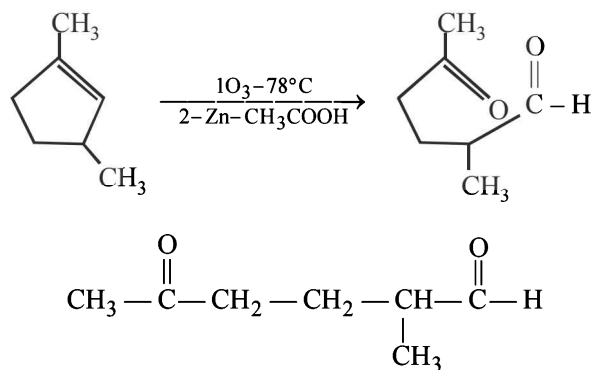

5- keto - 2 - methylhexanal

22. (d) Region 2 (blue flame) will be the hottest region of Bunsen flame shown in given figure

23. (d)  $\text{C}_x\text{H}_y(\text{g}) + \left(\frac{4x+y}{4}\right) \text{O}_2(\text{g}) \rightarrow x\text{CO}_2(\text{g}) + \frac{y}{2} \text{H}_2\text{O}(\text{l})$

$$\text{Volume of O}_2 \text{ used} = 375 \times \frac{20}{100} = 75 \text{ ml}$$

∴ From the reaction of combustion

$$1 \text{ ml C}_x\text{H}_y \text{ requires} = \frac{4x+y}{4} \text{ ml O}_2$$

$$15 \text{ ml} = 15 \left( \frac{4x+y}{4} \right) = 75$$

$$\text{So, } 4x+y=20$$

$$x=3$$

$$y=8$$

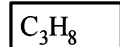

24. (d)

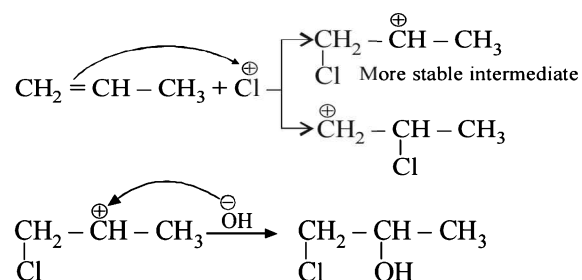

**Section-A : JEE Advanced/ IIT-JEE**

- C** 1. (a) 2. (a) 3. (d) 4. (a) 5. (a) 6. (b)  
 7. (a) 8. (d) 9. (b) 10. (c) 11. (d) 12. (b)  
 13. (a) 14. (b)
- D** 1. (a, c, d) 2. (b, c) 3. (a, b, d) 4. (a, d) 5. (a, c) 6. (a)  
 7. (b, c, d) 8. (b, c, d)
- E** 1. 2.91 Å 2. 1.86 Å 3. 25.93% 4. 124.27 pm, 7.30 g/ml  
 5. 1.259 7. (a) 25 8.  $5 \times 10^{-19} \text{ m}^2$  9. (a) 5.0 kg/m<sup>3</sup>, (b) metal excess defect  
 10. 117.16 pm 11. 2 12. 217 pm
- F** 1. (A - p, s); (B - p, q); (C - q); (D - q, r).
- G** 1. (b) 2. (a) 3. (d)
- H** 1. (a) 2. (b)
- I** 1. 8

**Section-B : JEE Main/ AIEEE**

1. (b) 2. (d) 3. (d) 4. (a) 5. (b) 6. (d) 7. (b)  
 8. (a) 9. (b) 10. (b) 11. (a) 12. (a) 13. (c) 14. (c)  
 15. (a) 16. (d) 17. (b) 18. (d) 19. (d) 20. (d) 21. (b)  
 22. (b) 23. (c) 24. (c) 25. (c) 26. (a)

**Section-A JEE Advanced/ IIT-JEE****C. MCQs with One Correct Answer**

1. (a) For bcc structure, atomic radius,  $r = \frac{\sqrt{3}}{4} a$

$$= \frac{\sqrt{3}}{4} \times 4.3 = 1.86$$

Since,  $r$  = half the distance between two nearest neighbouring atoms.

$$\therefore \text{Shortest inter ionic distance} = 2 \times 1.86 = 3.72$$

2. (a) In a hcp structure atoms are located at the corners and at centres of two hexagons placed parallel to each other ; three more atoms are placed in a parallel plane midway between these two planes. Here each atom is surrounded by 12 others and is said to have co-ordination number of 12.

3. (d) Effective number of 'A' atoms =  $\left(8 \times \frac{1}{8}\right) + \left(4 \times \frac{1}{2}\right) = 3$

$$\text{Effective number of 'B' atoms} = \left(12 \times \frac{1}{4}\right) + 1 = 4$$

$\therefore$  Formula of the solid =  $A_3B_4$ .

4. (a) Effective number of atoms at corners,  $A = 8 \times \frac{1}{8} = 1$

$$\text{Effective number of atoms at centre, } B = \frac{1}{2} \times 6 = 3$$

Thus, the composition will be  $AB_3$

5. (a) Rate of physiorption increases with decrease of temperature

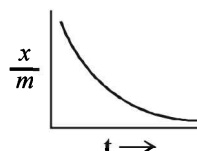

$\frac{x}{m}$  = amt of gas adsorbed per unit mass of adsorbent  
 $t$  = temperature

6. (b) When a gas is adsorbed on the surface, the freedom of movement of its molecules becomes restricted. This causes decrease in the entropy of the gas after adsorption, i.e.  $\Delta S$  becomes negative.
7. (b) In ZnS structure, sulphide ions occupy all FCC lattice points while  $Zn^{2+}$  ions are present in alternate tetrahedral voids.
8. (d) Lyophilic sols are self stabilizing because these sols are reversible and are highly hydrated in the solution.
9. (b) We know that surface acting agents (i.e. surfactants) such as soaps and detergents belong to the class of micelles. A micellar system when dissolved in water, dissociates to give ions. The anion consists of two

parts. The polar groups such as  $(COO^- \text{ or } SO_4^{--})$  ion is water loving (i.e. hydrophilic) in nature. It is called head of the species. The hydrocarbon chain which is quite big in size is water repelling (i.e. hydrophobic) in nature. It is called tail of the species. The hydrocarbon chain aggregates into the micelle above the critical concentration.

**NOTE :** It may also be noted that the critical concentration for micelle formation decreases with increase in the molecular weight of the hydrocarbon chain of surfactant.

Here the two anions that are formed are in case of "B" (i.e.  $CH_3(CH_2)_{11}OSO_3^-$ ) and "C" (i.e.  $CH_3(CH_2)_6COO^-$ ) The molecular weight of hydrocarbon chain is more in case of "B" so it has lower value of critical concentration for micelle formation in aqueous solution.

Hence the correct answer is option (b).

10. (c) As  $Sb_2S_3$  is a negative sol, so  $Al_2(SO_4)_3$  will be the most effective coagulant due to higher positive charge on Al ( $Al^{3+}$ ) – **Hardy-Schulze rule**.
11. (d) Packing efficiency =  $\frac{\text{Area occupied by effective circles}}{\text{Area of square}}$
- $$= \frac{2\pi r^2}{l^2} \times 100 = \frac{2\pi r^2}{2(\sqrt{2}r)^2} \times 100 = \frac{\pi}{4} \times 100 = 78.54\%$$
12. (b) No. of M atoms =  $\frac{1}{4} \times 4 + 1 = 1 + 1 = 2$
- $$\text{No. of X atoms} = \frac{1}{2} \times 6 + \frac{1}{8} \times 8 = 3 + 1 = 4$$
- So, formula =  $M_2X_4 = MX_2$
13. (a) The arrangement given shows octahedral void arrangement-limiting radius ratio for octahedral void is
- $$\frac{r_{A^+}}{r_{X^-}} = 0.414$$
- $$r_{A^+} = 0.414 \times r_{X^-} = 0.414 \times 250 = 103.5 \approx 104 \text{ pm.}$$
14. (b) The adsorption of methylene blue on activated charcoal is an example of physisorption which is exothermic, multilayer and does not have energy barrier.

#### D. MCQs with One or More Than One Correct

1. (a,c,d) The crystals of CsCl has body - centred cubic unit cell. Hence, each ion in this structure has coordination number of eight.
- NOTE :** In case of crystals of NaCl two interpenetrating face-centred cubic lattices are present, one of these is composed entirely of  $Na^+$  ions and the other of  $Cl^-$  ions. Each  $Na^+$  ion is located half way between two  $Cl^-$  ions and viceversa. A unit cell of NaCl crystal has  $Cl^-$  ions at the corners as well as at the face centres and  $Na^+$  ions are located in octahedral voids. On each edge of cubic unit cell, there are two  $Cl^-$  ions and one  $Na^+$  ions. Hence
- $$a = 2(r_{Na^+} + r_{Cl^-}) = 2(95 \text{ pm} + 181 \text{ pm}) = 552 \text{ pm.}$$
2. (b,c) Frenkel defect is a dislocation effect, observed when the size of the cation and anion differ largely. F-center is created when an anion is lost from the lattice and vacancy is filled by trapping of an electron. Schottky defect changes the density of a crystalline solid.
3. (a, b, d)
- (a)  $\Delta H$  is negative for adsorption
- (b) Fact based
- (d) Chemical bonds are stronger than vander Waal's forces, so chemical adsorption is more exothermic.
4. (a, d)
5. (a, c) Graph (I) and (III) represent physisorption because, in physisorption, the amount of adsorption decreases with the increase of temperature and increases with the increase of pressure.
- Graph (II) represent chemisorption, because in chemisorption amount of adsorption increases with the increase of temperature. Graph (IV) is showing the formation of a chemical bond, hence chemisorption.
6. (a) In *ccp*,  $O^{2-}$  ions are 4.
- Hence total negative charge =  $-8$
- Let  $Al^{3+}$  ions be  $x$ , and  $Mg^{2+}$  ions be  $y$ .
- Total positive charge =  $3x + 2y$
- $$\Rightarrow 3x + 2y = 8$$
- This relation is satisfied only by  $x = 2$  and  $y = 1$ .
- Hence number of  $Al^{3+} = 2$ .
- and number of  $Mg^{2+} = 1$ .
- $$\Rightarrow n = \text{fraction of octahedral holes occupied by } Al^{3+}$$
- $$= \frac{2}{4} = \frac{1}{2}$$
- and  $m = \text{fraction of tetrahedral holes occupied by } Mg^{2+}$
- $$= \frac{1}{8}$$
7. (b, c, d) Reaction on metal surface
- $$M \longrightarrow M^+ + e^-$$
- $$O_2 + e^- \longrightarrow O_2^-$$
- This is an example of chemisorption.

8. (b, c, d)

CCP is ABC ABC ..... type packing

(A) In topmost layer, each atom is in contact with 6 atoms in same layer and 3 atoms below this layer

$$\frac{4 \times \frac{4}{3} \pi r^3}{3} = (0.74)$$

(B) Packing fraction =  $\left(\frac{4r}{\sqrt{2}}\right)^3$ (C) Each FCC unit has effective no of atoms = 4  
Octahedral void = 4  
Tetrahedral void = 8(D)  $4r = a\sqrt{2}$ **E. Subjective Problems**1. Avogadro's number =  $6.023 \times 10^{23}$ 

At. wt. of mercury (Hg) = 200

 $\therefore$  In 1 g of Hg, the total number of atom

$$= \frac{6.023 \times 10^{23}}{200} = \frac{6.023 \times 10^{23}}{2 \times 10^2}$$

$$= 3.0115 \times 10^{21} = 3.012 \times 10^{21}$$

Density of Mercury (Hg) = 13.6 g/c.c.

 $\therefore$  mass of  $3.012 \times 10^{21}$  atoms = 1g

$$\therefore \text{mass of } 3.012 \times 10^{21} \text{ atoms} = \frac{1}{3.012 \times 10^{21}}$$

Now volume of 1 atom of mercury (Hg)

$$= \frac{1}{3.012 \times 10^{21} \times 13.6} \text{ c.c.} = \frac{10^3 \times 10}{3012 \times 10^{21} \times 136} \text{ c.c.}$$

$$= \frac{10^{-17}}{3012 \times 136} \text{ c.c.} = \frac{10^{-17}}{409632} \text{ c.c.} = \frac{1000000 \times 10^{-23}}{409632} \text{ c.c.}$$

$$= 2.44 \times 10^{-23} \text{ c.c.}$$

Since each mercury atom occupies a cube of edge length equal to its diameter, therefore,

$$\text{diameter of one Hg atom} = (2.44 \times 10^{-23})^{\frac{1}{3}} \text{ cm}$$

$$= (24.4 \times 10^{-24})^{\frac{1}{3}} \text{ cm.}$$

$$= 2.905 \times 10^{-8} \text{ cm} \cong 2.91 \text{ \AA}$$

2. TIPS/Formulae :

For bcc lattice, (radius),  $r = \frac{\sqrt{3}a}{4}$ 

Solution

$$\therefore r = \frac{\sqrt{3} \times 4.29 \text{ \AA}}{4} = \frac{1.73 \times 4.29 \text{ \AA}}{4} = 1.86 \text{ \AA}$$

3. For a hcp unit cell, there are 6 atoms per unit cell. If  $r$  is the radius of the metal atoms, volume occupied by the metallic

$$\text{atoms} = 6 \times \frac{4}{3} \times \pi \times r^3 = 6 \times 1.33 \times \frac{22}{7} \times r^3 = 25.08 \times r^3$$

Geometrically it has been shown that the base area of hcp unit cell

$$= 6 \times \frac{\sqrt{3}}{4} \times 4r^2 \text{ and the height} = 4r \times \sqrt{\frac{2}{3}}$$

 $\therefore$  Volume of the unit cell

$$= \text{Area} \times \text{height} = 6 \times \frac{\sqrt{3}}{4} \times 4r^2 \times 4r \times \sqrt{\frac{2}{3}} = 33.94 r^3$$

$$\therefore \text{Volume of the empty space of one unit cell} = 33.94 r^3 - 25.08 r^3 = 8.86 r^3$$

$$\therefore \text{Percentage void} = \frac{8.816 r^3}{33.94 r^3} \times 100 = 26.1\%$$

4. For bcc lattice,  $r = \frac{\sqrt{3} \times a}{4} = \frac{\sqrt{3}}{4} \times 287 = 124.27 \text{ pm}$ 

$$\text{Now Density} = \frac{n \times \text{at. wt.}}{V \times \text{Av. No.}} = \frac{n \times \text{at. wt.}}{a^3 \times \text{Av. No.}}$$

$$n = 2 \text{ for bcc; } a = 287 \times 10^{-10} \text{ cm}$$

$$\therefore \text{Density} = \frac{2 \times 51.99}{(287 \times 10^{-10})^3 \times 6.023 \times 10^{23}} = 7.30 \text{ g/ml}$$

5. TIPS/Formulae : Density in fcc =  $\frac{n_1 \times \text{at. wt.}}{V_1 \times \text{No.}}$ 

$$\text{Density in bcc} = \frac{n_2 \times \text{at. wt.}}{V_2 \times \text{No.}}$$

fcc unit cell length =  $3.5 \text{ \AA}$ ; bcc unit cell length =  $3.0 \text{ \AA}$ 

$$\text{Density in fcc} = \frac{n_1 \times \text{at. wt.}}{V_1 \times \text{Av. No.}}$$

$$\text{Density in bcc} = \frac{n_2 \times \text{at. wt.}}{V_2 \times \text{Av. No.}}$$

$$\therefore \frac{D_{\text{fcc}}}{D_{\text{bcc}}} = \frac{n_1 \times V_2}{n_2 \times V_1}$$

$$n_1 \text{ for fcc} = 4; \text{ Also } V_1 = a^3 = (3.5 \times 10^{-8})^3$$

$$n_2 \text{ for bcc} = 2; \text{ Also } V_2 = a^3 = (3.0 \times 10^{-8})^3$$

$$\therefore \frac{D_{\text{fcc}}}{D_{\text{bcc}}} = \frac{4 \times (3.0 \times 10^{-8})^3}{2 \times (3.5 \times 10^{-8})^3} = 1.259$$

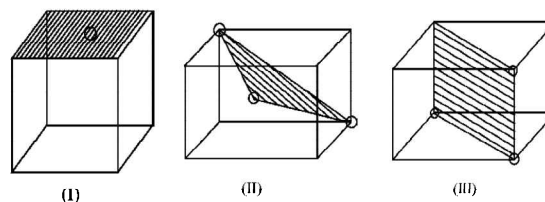

6.

7. The area of square =  $4 \times 4 = 16 \text{ cm}^2$ 

Again to have the maximum number of spheres the packing must be hcp.

$$\text{Maximum number of spheres} = 14 + \frac{8}{2} = 14 + 4 = 18.$$

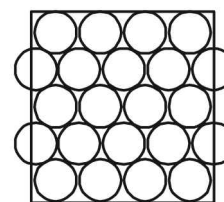
Area =  $16 \text{ cm}^2$ 

$$\therefore \text{Number of spheres per } \text{cm}^2 = \frac{18}{16} = 1.126$$



8. Number of moles of acetic acid in 100 ml before adding charcoal = 0.05  
 Number of moles of acetic acid in 100 ml after adding charcoal = 0.049  
 Number of moles of acetic acid adsorbed on the surface of charcoal = 0.001  
 Number of molecules of acetic acid adsorbed on the surface of charcoal =  $0.001 \times 6.02 \times 10^{23} = 6.02 \times 10^{20}$   
 Surface area of charcoal =  $3.01 \times 10^2 \text{ m}^2$  (given)  
 Area occupied by single acetic acid molecule on the surface of charcoal  $\frac{3.01 \times 10^2}{6.02 \times 10^{20}} = 5 \times 10^{-19} \text{ m}^2$

9. (a) **TIPS/Formulae** : Density of AB =  $\frac{Z \times M}{N_0 \times a^3}$

Here,  $Z = 4$  (for fcc),  $M = 6.023 Y$ ,  
 $a = 2 Y^{1/3} \text{ nm} = 2 Y^{1/3} \times 10^{-9} \text{ m}$   
 Thus,

$$\text{Density} = \frac{4 \times 6.023 Y}{6.023 \times 10^{23} \times (2 Y^{1/3} \times 10^{-9})^3}$$

$$= 5.0 \text{ kg m}^{-3}$$

- (b) Since the observed density ( $20 \text{ kg m}^{-3}$ ) of AB is higher than the calculated ( $5 \text{ kg m}^{-3}$ ), the compound must have **metal excess defect**. non-stoichiometric defect.
10. **TIPS/Formulae** : For an octahedral void  $a = 2(r + R)$

In fcc lattice the largest void present is octahedral void. If the radius of void sphere is  $R$  and of lattice sphere is  $r$ . Then,

$$r = \frac{\sqrt{2} \times 400}{4} = 141.12 \text{ pm} \quad (a = 400 \text{ pm})$$

Applying condition for octahedral void,  $2(r + R) = a$

$$\therefore 2R = a - 2r = 400 - 2 \times 141.12$$

$$\therefore \text{Diameter of greatest sphere} = 117.16 \text{ pm}$$

11.  $P_{N_2} = 0.001 \text{ atm}$ ,  $T = 300 \text{ K}$ ,  $V = 2.46 \text{ cm}^3$

$\therefore$  Number of  $N_2$  molecules

$$= \frac{PV}{RT} \times N_{AV} = \frac{0.001 \times 2.46 \times 10^{-3}}{0.0821 \times 300} \times 6.023 \times 10^{23}$$

$$= 6.016 \times 10^{16}$$

Now total number of surface sites = Density  $\times$  Total surface area

$$= 6.023 \times 10^{14} \times 1000 = 6.023 \times 10^{17}$$

$$\text{Sites occupied by } N_2 \text{ molecules} = \frac{20}{100} \times 6.023 \times 10^{17}$$

$$= 12.04 \times 10^{16}$$

$\therefore$  No. of sites occupied by each  $N_2$  molecule

$$= \frac{12.04 \times 10^{16}}{6.016 \times 10^{16}} \approx 2$$

12. **TIPS/Formulae** : For bcc;  $r = \frac{\sqrt{3}}{2} a$ ;

$$d = \frac{n \times M}{N_{AV} \times a^3} \quad \text{or} \quad n = \frac{d \times N_{AV} \times a^3}{M}$$

$$\Rightarrow n = \frac{2 \times 6 \times 10^{23} (5 \times 10^{-8})^3}{75} = 2$$

Therefore Metal crystallizes in BCC structure and for a BCC lattice  $\sqrt{3}a = 4r$

$$r = \frac{\sqrt{3}}{4} a = \frac{\sqrt{3} \times 5}{4} = 2.165 \text{ \AA} = 216.5 \text{ pm}$$

So the required answer is 217 pm.

### F. Match the Following

1. **A-p, s; B-p,q; C-q; D-q, r.**

A  $\rightarrow$  p, s; Parameters of a cubic system are  $a = b = c$  and  $\alpha = \beta = \gamma = 90^\circ$

There are three types of lattices in cubic system

These are simple, Face centred and body centred

B  $\rightarrow$  p, q; The parameters of a Rhombohedral system are  $a = b = c$ ,  $\alpha = \beta = \gamma = 90^\circ$

Cubic and Rhombohedral are two crystal systems. There are seven crystal systems in all

C  $\rightarrow$  q; These are two crystal systems.

D  $\rightarrow$  q, r; Hexagonal and monoclinic are two crystal systems. The parameters of these are

Hexagonal;  $a = b \neq c$  and  $\alpha = \beta = 90^\circ$ ,  $\gamma = 120^\circ$

Monoclinic;  $a \neq b \neq c$  and  $\alpha = \gamma = 90^\circ$ ,  $\beta \neq 90^\circ$

### G. Comprehension Based Questions

1. (b) In 1 unit cell of hcp, the number of atoms can be calculated as follows

Number of atoms in a unit cell of hcp

$$= 12 \times \frac{1}{6} + 2 \times \frac{1}{2} + 3 = 6$$

i.e. the correct answer is option (b)

[NOTE : : in a hexagonal close packing (hcp) the spheres in the first and third layers are vertically aligned. (See figure below)]

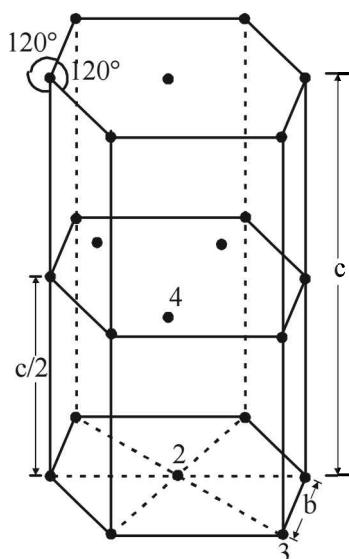

2. (a) The volume of hcp unit cell is given by the formula:-  
Volume of hexagon = Area of base  $\times$  height
- $$= 6 \times \frac{\sqrt{3}}{4} (2r)^2 \times 4r \sqrt{\frac{2}{3}}$$
- $$= 24\sqrt{2} r^3$$
- i.e. the correct answer is option (a)
3. (d) In a hcp unit cell the space occupied is 74%, as calculated below

$$\text{Packing fraction} = \frac{\text{Volume of the atoms in a unit cell}}{\text{Volume of a unit cell}}$$

$$= \frac{6 \times \frac{4}{3} \pi r^3}{24\sqrt{2} r^3} = \frac{\pi}{3\sqrt{2}} = \frac{22}{7} \times \frac{1}{3\sqrt{2}}$$

$$= 0.74 \text{ or } 74\%$$

$\therefore$  Empty space in HCP unit cell =  $(100 - 74)\% = 26\%$   
i.e. the correct answer is option (d).

### H. Assertion & Reason Type Questions

- (a) Schottky defect is defined as a vacancy developed for anion and cation site, so cation and anion vacancy will be same in number. Therefore an ionic solid MX with Schottky defects will still have the same number of anions and cations.
- (b) Statement-1 is correct because the surfactant molecules aggregate to form micelles only at or above the critical micellar concentration (CMC). Although statement-2 is also correct, i.e., the conductivity of the solution having surfactant molecules decreases sharply at CMC. However, statement-2 is not the explanation for statement-1. The explanation is that "each micelle contains at least 100 molecules" and thus, with the formation of micelles, the number of ions in solution decreases and mobility of the bulkier micelle particles decreases. This, finally leads to decrease in conductivity of the solution.

## Section-B JEE Main/ AIEEE

- (b) It is zero order reaction  
[NOTE : Adsorption of gas on metal surface is of zero order]
- (d) In bcc - points are at corners and one in the centre of the unit cell.  
  
Number of atoms per unit cell =  $8 \times \frac{1}{8} + 1 = 2$ .  
  
In fcc - points are at the corners and also centre of the six faces of each cell.  
  
Number of atoms per unit cell =  $8 \times \frac{1}{8} + 6 \times \frac{1}{2} = 4$ .
- (d) Since in NaCl type of structure 4 formula units form a cell. Number of formulas in cube shaped crystals  
$$= \frac{1.0}{58.5} \times 6.02 \times 10^{23}$$
  
No. of unit cells present in a cubic crystal =  
$$\frac{P \times a^3 \times N_A}{M \times Z} = \frac{m \times N_A}{M \times Z}$$
  
$$\therefore \text{units cells} = \frac{1.0 \times 6.02 \times 10^{23}}{58.5 \times 4} = 2.57 \times 10^{21} \text{ unit cells.}$$
- (a) As adsorption is an exothermic process.  
 $\therefore$  Rise in temperature will decrease adsorption (according to Le-chatelier principle).
- (b) When equal number of cations and anions are missing from their regular lattice positions, we have schottky defect. This type of defects are more common in ionic compounds with high co-ordination number and where the size of positive and negative ions are almost equal e.g. NaCl KCl etc.
- (d) Enzymes are very specific biological catalysts possessing well - defined active sites
- (b) Number of A ions in the unit cell. =  $\frac{1}{8} \times 8 = 1$   
  
Number of B ions in the unit cell =  $\frac{1}{2} \times 6 = 3$   
Hence empirical formula of the compound =  $AB_3$
- (a) Particle size of colloidal particle =  $1\text{m}\mu$  to  $100\text{m}\mu$   
(suppose  $10\text{m}\mu$ )  
$$V_c = \frac{4}{3} \pi r^3 = \frac{4}{3} \pi (10)^3$$
  
Particle size of true solution particle =  $1\text{m}\mu$   
$$V_s = \frac{4}{3} \pi (1)^3 \text{ hence now } \frac{V_c}{V_s} = 10^3$$

9. (b) When oppositely charged sols are mixed their charges are neutralised. Both sols may be partially or completely precipitated.

10. (b) The face centered cubic unit cell contains 4 atom

$$\therefore \text{Total volume of atoms} = 4 \times \frac{4}{3} \pi r^3 = \frac{16}{3} \pi r^3$$

11. (a) According to Langmuir's Model of adsorption of a gas on a solid surface the mass of gas adsorbed ( $x$ ) per gram of the adsorbent ( $m$ ) is directly proportional to the pressure of the gas ( $p$ ) at constant temperature i.e.

$$\frac{x}{m} \propto p$$

12. (a) From the given data, we have  
Number of Y atoms in a unit cell = 4

$$\text{Number of X atoms in a unit cell} = 8 \times \frac{2}{3} = \frac{16}{3}$$

From the above we get the formula of the compound as

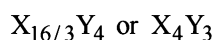

13. (c) For a protective colloid  $\mu$  lesser the value of gold number better is the protective power.

Thus the correct order of protective power of A, B, C and D is

$$\Rightarrow (A) < (C) < (B) < (D)$$

$$\text{Gold number } \begin{matrix} 0.50 & 0.10 & 0.01 & 0.005 \end{matrix}$$

Hence (c) is the correct answer

14. (c) Adsorption is an exothermic process, hence  $\Delta H$  will always be negative

15. (a) For fcc unit cell,  $4r = \sqrt{2} a$ ;  $r = \frac{\sqrt{2} \times 361}{4} = 127 \text{ pm}$

16. (d) For an Fcc crystal

$$r_{\text{cation}} + r_{\text{anion}} = \frac{\text{edge length}}{2}; 110 + r_{\text{anion}} = \frac{508}{2}$$

$$r_{\text{anion}} = 254 - 110 = 144 \text{ pm}$$

17. (b) Packing fraction is defined as the ratio of the volume of the unit cell that is occupied by the spheres to the volume of the unit cell.

P.F. for ccp and bcc are 0.74 and 0.68 respectively.

So, the free space in ccp and bcc are 26% & 32% respectively.

18. (d) No. of atoms in the corners (A) =  $8 \times \frac{1}{8} = 1$

$$\text{No. of atoms at face centres (B)} = 5 \times \frac{1}{2} = 2.5$$

$\therefore$  Formula is =  $AB_{2.5}$  or  $A_2B_5$

19. (d) For BCC structure  $\sqrt{3}a = 4r$

$$r = \frac{\sqrt{3}}{4} a = \frac{\sqrt{3}}{4} \times 351 = 152 \text{ pm.}$$

20. (d) The Freundlich adsorption isotherm is mathematically represented as  $\frac{x}{m} = kP^{1/n}$

at high pressure  $1/n = 0$ . Hence,  $x/m \propto P^0$

at low pressure  $1/n = 1$  Hence,  $x/m \propto P$

21. (b) Among the given crystals only silicon is as a covalent solid.

22. (b) According to Hardy Schulze rule, greater the charge on cation, greater is its coagulating power for negatively charged solution. hence the correct order of coagulating power :  $Na^+ < Ba^{2+} < Al^{3+}$

23. (c)

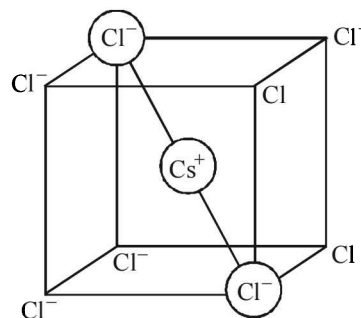

Relation between radius of cation, anion and edge length of the cube

$$2r_{Cs^+} + 2r_{Cl^-} = \sqrt{3}a \Rightarrow r_{Cs^+} + r_{Cl^-} = \frac{\sqrt{3}a}{2}$$

24. (c) In bcc the atoms touch along body diagonal

$$\therefore 2r + 2r = \sqrt{3}a$$

$$\therefore r = \frac{\sqrt{3}a}{4} = \frac{\sqrt{3} \times 4.29}{4} = 1.857 \text{ \AA}$$

25. (c) Let the weight of acetic acid initially be  $w_1$  in 50 ml of 0.060 N solution.

$$\text{Let the } N = \frac{w_1 \times 1000}{\text{M. wt.} \times 50} \quad (\text{Normality} = 0.06 \text{ N})$$

$$0.06 = \frac{w_1 \times 1000}{60 \times 50}$$

$$\Rightarrow w_1 = \frac{0.06 \times 60 \times 50}{1000} = 0.18 \text{ g} = 180 \text{ mg.}$$

After an hour, the strength of acetic acid = 0.042 N so, let the weight of acetic acid be  $w_2$

$$N = \frac{w_2 \times 1000}{60 \times 50}; 0.042 = \frac{w_2 \times 1000}{3000}$$

$$\Rightarrow w_2 = 0.126 \text{ g} = 126 \text{ mg}$$

So amount of acetic acid adsorbed per 3g =  $180 - 126 \text{ mg} = 54 \text{ mg}$

Amount of acetic acid adsorbed per g

$$= \frac{54}{3} = 18 \text{ mg}$$

26. (a) According to Freundlich adsorption isotherm

$$\log \frac{x}{m} = \log K + \frac{1}{n} \log P$$

Thus if a graph is plotted between  $\log(x/m)$  and  $\log P$ , a straight line will be obtained

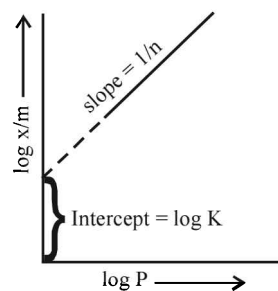

The slope of the line is equal to  $1/n$  and the intercept on  $\log x/m$  axis will correspond to  $\log K$ .

**Section-A : JEE Advanced/ IIT-JEE**

- A** 1.  $K_f$
- C** 1. (c)      2. (b)      3. (a)      4. (a)      5. (d)      6. (a)      7. (b)  
8. (a)      9. (a)      10. (a)      11. (a)      12. (c)      13. (a)      14. (a)
- D** 1. (a, d)      2. (b, c, d)      3. (a, b)
- E** 1. 1.38 M, 1.57 m, 184 ml      2. 15.81M; 12.65      3. 3.84%      4. 0.156 m/kg  
5.  $(\text{CH}_2\text{O})_5$  or  $\text{C}_5\text{H}_{10}\text{O}_5$       7. 66.17 mm, 0.65  
8. 0.7503 mol/kg, 0.9868      9. 65.25      10. 746.3 mm Hg  
11. 156.056      12. 18.52 m      13. 0.73      14. 23.44 mm Hg  
15. 168 g,  $\text{C}_6\text{H}_4(\text{NO}_2)_2$ , m-dinitrobenzene      16. 0.228 K  
17. 122,224      18. 75%
- G** 1. (d)      2. (b)      3. (b)
- I** 1. 8      2. 2      3. 8      4. 1      5. 9

**Section-B : JEE Main/ AIEEE**

1. (b)      2. (d)      3. (d)      4. (d)      5. (a)      6. (c)      7. (d)  
8. (b)      9. (d)      10. (d)      11. (d)      12. (d)      13. (b)      14. (b)  
15. (d)      16. (a)      17. (d)      18. (a)      19. (b)      20. (b)      21. (b)  
22. (a)      23. (c)      24. (a)      25. (a)      26. (d)      27. (b)      28. (a)  
29. (a)      30. (d)      31. (a)

**Section-A JEE Advanced/ IIT-JEE****A. Fill in the Blanks**

1.  $K_f$ ; Depression in freezing point,  $\Delta T_f = K_f \cdot m$ , where  $K_f$  is the molar depression constant or cryoscopic constant and  $m$  is the molality of the solution given by moles of solute per 1000 g of the solvent.

**C. MCQs with One Correct Answer**

1. (c) Lower the B. pt., higher will be the V.P. The V.P. of the mixture is greater than either of the two liquids.  
[NOTE : : In case of positive deviation from Raoult's law the partial vapour pressure of each liquid and total vapour pressure of solution will be greater as compared to initial solution]

2. (b)  $\frac{p^\circ - p}{p^\circ} = \frac{\frac{w}{m}}{\frac{w}{m} + \frac{W}{M}} = \text{mole fraction of solute} = x_B$

[Mathematical statement of Raoult's law]

3. (a) Added  $\text{HgI}_2$  forms a complex with KI in the solution as follows

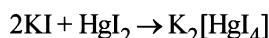

As a result, number of particles decreases and so  $\Delta T_f$  increases.

[NOTE : : Depression in freezing point is a colligative property]

4. (a) NOTE : The salt producing highest number of ions will have lowest freezing point.

$\text{K}_2\text{SO}_4 \rightarrow 2\text{K}^+ + \text{SO}_4^{2-}$ ;  $\text{K}_2\text{SO}_4$  gives highest number of particles ( $2 + 1 = 3$ ).

Glucose, being non-electrolyte gives minimum no. of particles and hence minimum  $\Delta T_f$  or maximum F. pt.

5. (d) TIPS/Formulae : The salt that ionises to least extent will have highest freezing point. [i.e., minimum  $\Delta T_f$ ]  
Glucose, being non electrolyte, gives minimum no. of particles and hence minimum  $\Delta T_f$  or maximum F. pt

## Solutions

6. (a) Depression in freezing point,  $\Delta T_f = i \times K_f \times m$

Van't Hoff factor,  $i = \frac{1 - \alpha + n\alpha}{1}$ , where  $n$  = no. of ions

produced by complete dissociation of 1 mole of HX.

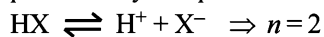

$$\therefore i = \frac{1 - 0.2 + 2 \times 0.2}{1} = 1.2$$

[For 20% ionisation,  $\alpha = \frac{20}{100} = 0.2$ ]

$$\therefore \Delta T_f = 1.2 \times 1.86 \times 0.2 = 0.45 \quad [\because m=0.2]$$

Hence freezing point of solution is  $0 - 0.45 = -0.45$

[ $\because$  F.P of water = 0.0 C]

7. (b) Benzoic acid exists as dimer in benzene.

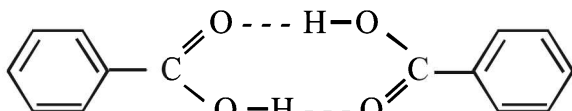

[Normal molecular mass = 122 amu  
observed molecular mass = 244 amu, in case of complete association]

$$\alpha = \frac{20}{100} = 0.2 \quad \alpha = \frac{20}{100} = 0.2 \quad \alpha = \frac{20}{100} = 0.2$$

8. (a) **NOTE** : At the freezing point liquid and solid remain in equilibrium. If a solution of a non-volatile solute is cooled to a temperature below the freezing point of solution, some of liquid solvent will separate as a solid solvent and thus the concentration of solution will increase.

9. (a) TIPS/Formulae:

$$(i) \quad i = \frac{\text{No. of particles after ionisation}}{\text{No. of particles before ionisation}}$$

$$(ii) \quad \Delta T_b = i \times K_b \times m$$

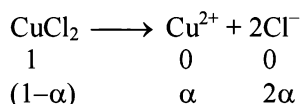

$$i = \frac{1 + 2\alpha}{1} \quad i = 1 + 2\alpha$$

Assuming 100% ionization So,  $i = 1 + 2 = 3$

$$\Delta T_b = 3 \times 0.52 \times 0.1 = 0.156 \approx 0.16 \quad [m = \frac{13.44}{134.4} = 0.1]$$

10. (a) Molecular weight of naphthoic acid

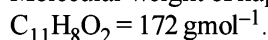

The theoretical value of depression in freezing point

$$= K_f \times \text{molality} = 1.72 \times \frac{20 \times 1000}{172 \times 50} = 4K$$

Van't Hoff factor,

$$i = \frac{\text{Observed value of colligative property}}{\text{Theoretical value of colligative property}}$$

$$= \frac{2}{4} = 0.5$$

11. (a)  $P_{\text{N}_2} = \kappa_{\text{H}} \chi_{\text{N}_2}$ ;  $0.8 \times 5 = 1 \times 10^5 \times \chi_{\text{N}_2}$

$$\therefore \chi_{\text{N}_2} = 4 \times 10^{-5}; \text{Solubility in 10 moles} = 4 \times 10^{-4}$$

12. (c) Number of moles of urea =  $\frac{120}{60} = 2$

$$\text{Total mass of solution} = 1000 + 120 = 1120 \text{ g}$$

$$\text{Total volume of solution (in L)} = \frac{\text{Mass}}{\text{Density}}$$

$$= \frac{1120}{1.15 \times 10^3} = \frac{112}{115} \text{ L}$$

$$\text{Molarity of the solution} = \frac{\text{Number of moles}}{\text{Volume in L}}$$

$$= \frac{2 \times 115}{112} = 2.05 \text{ mol L}^{-1}$$

13. (a)  $\Delta T_f = i \times K_f \times m$

Where  $m$  = Molality of the solution

(i.e. number of moles of solute per 1000 g of the solvent)

$$\text{Here } m = \frac{0.1}{329} \times 100$$

$$\text{Thus } \Delta T_f = 4 \times 1.86 \times \frac{0.1 \times 100}{329} = 2.3 \times 10^{-2}$$

$$\text{Thus } T_f = 0 - 2.3 \times 10^{-2} = -2.3 \times 10^{-2} \text{ }^\circ\text{C}$$

14. (a) From Raoult law relation,

$$\frac{p^\circ - p}{p^\circ} = \frac{\text{No. of moles of solute}}{\text{No. of moles of solvent} + \text{No. of moles of solute}}$$

When the concentration of solute is much lower than the concentration of solvent,

$$\frac{p^\circ - p}{p^\circ} = \frac{\text{No. of moles of solute}}{\text{No. of moles of solvent}}$$

$$\frac{760 - p}{760} = \frac{2.5/m}{100/18} \quad \dots(i)$$

$$\text{From elevation in boiling point, } \Delta T_b = K_b \times m$$

$$2 = 0.76 \times m$$

$$m = \frac{2}{0.76} \quad \dots(ii)$$

From (i) and (ii),  $p = 724 \text{ mm}$

#### D. MCQs with One or More Than One Correct

1. (a, d) The freezing point of a solvent depresses as a non-volatile solute is added to a solvent. According to Raoult's law, when a non-volatile solute is added to a solvent the vapour pressure of the solvent decreases. At the freezing point it will be only the solvent molecules which will solidify.
2. (b, c, d)

$$\text{For ideal solution, } \Delta S_{\text{system}} > 0$$

$$\Delta S_{\text{surrounding}} = 0; \quad \Delta H_{\text{mixing}} = 0$$

3. (a, b)  
 (A) H-bonding of methanol breaks when  $\text{CCl}_4$  is added so bonds become weaker, resulting positive deviation.  
 (B) Mixing of polar and non-polar liquids will produce a solution of weaker interaction, resulting positive deviation  
 (C) Ideal solution  
 (D) -ve deviation because stronger H-bond is formed.

### E. Subjective Problems

#### 1. TIPS/Formulae :

$$(i) \text{ Molarity} = \frac{\text{Moles of solute}}{\text{Volume of solution in L}}$$

$$(ii) N_1 V_1 = N_2 V_2$$

A 13% solution (by weight) contains 13g of solute (i.e.  $\text{H}_2\text{SO}_4$ ) per 100 gm of solution

$$\text{Moles of solute} = \frac{\text{Mass of } \text{H}_2\text{SO}_4}{\text{M. wt. of } \text{H}_2\text{SO}_4} = \frac{13}{98} = 0.1326$$

Volume of solution in L

$$= \frac{\text{Mass of solution}}{\text{density of solution} \times 1000} = \frac{100}{1.02 \times 1000} = 0.0980 \text{ Litre}$$

$$\therefore \text{ Molarity of solution} = \frac{0.1326}{0.0980} = \mathbf{1.35 \text{ M}}$$

$$\text{Again, Molality} = \frac{\text{Moles of solute}}{\text{Mass of solvent in kg}}$$

Mass of solute in 100 ml of solution = 13 g [ 13 % solution ]

Mass of solvent = Mass of solution - Mass of solute  
 = 100 - 13 = 87 g

$$\therefore \text{ Molality} = \frac{13/98}{87/1000} = \mathbf{1.57 \text{ m}}$$

$$\text{Normality} = \text{Molarity} \times \frac{\text{Mol. wt.}}{\text{Eq. wt.}} \text{ or } 1.35 \times \frac{98}{49} = 2.70 \text{ N}$$

$$N_1 = 2.70, V_1 = 100 \text{ ml}, N_2 = 1.5, V_2 = ? \quad \left[ \begin{array}{l} \therefore \text{Eq. wt} = \frac{98}{2} \\ 2\text{H}_2\text{SO}_4 = 49 \end{array} \right]$$

$$N_1 V_1 = N_2 V_2; 2.70 \times 100 = 1.5 \times V_2$$

$$\text{or } V_2 = \frac{2.70 \times 100}{1.5} = 180 \text{ ml.}$$

$\therefore$  100 ml of this acid should be diluted to 180 ml to prepare 1.5 N solution.

$$2. \quad M = \frac{86/98}{100/1.787} \times 1000 = \frac{0.8775}{55.5} \times 1000 = \mathbf{15.81 \text{ M}}$$

$$M_1 V_1 = M_2 V_2$$

$$M_1 = 15.81, V_1 = ?$$

$$M_2 = 0.2, V_2 = 1 \text{ L} = 1000 \text{ ml}$$

$$\therefore 15.81 \times V_1 = 0.2 \times 1000$$

$$\text{or } V_1 = \frac{0.2 \times 1000}{15.81} = 12.65 \text{ ml}$$

$\therefore$  Amount of acid to be used to make 1 L of 0.2 M  $\text{H}_2\text{SO}_4$  = **12.65.**

$$3. \quad N_1 = 1, V_1 = ?, N_2 = 26.7, V_2 = 0.4$$

$$N_1 V_1 = N_2 V_2; 1 \times V_1 = 26.7 \times 0.4$$

$$V_1 = \frac{26.7 \times 0.4}{1} = 10.68$$

49g ( $\therefore$  eq wt of  $\text{H}_2\text{SO}_4 = 49$ ) of  $\text{H}_2\text{SO}_4$  will be neutralised by = 1N 1000 ml NaOH

$\therefore$  0.5g of  $\text{H}_2\text{SO}_4$  will be neutralised by

$$= \frac{1000}{49} \times 0.5 = 10.20 \text{ ml 1N NaOH}$$

Volume of 1 N NaOH used by dissolved

$$\text{SO}_3 = 10.68 - 10.20 = 0.48 \text{ ml}$$

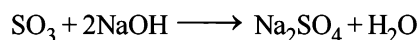

$$\therefore \text{ Eq wt of } \text{SO}_3 = \frac{\text{Mol wt}}{2} = \frac{80}{2} = 40$$

Wt of  $\text{SO}_3$  in 0.48 ml of 1 M solution

$$= \frac{40}{1000} \times 0.48 = 0.0192 \text{ g}$$

$$\% \text{ of } \text{SO}_3 = \frac{0.0192}{0.5} \times 100 = \mathbf{3.84\%}$$

$$4. \quad \text{TIPS/Formulae : } \frac{P^\circ - P}{P^\circ} = \frac{n}{N} \text{ [ Raoult's Equation ]}$$

Let the molality of the solution = m

Now the solution contains 'm' moles of solute per 1000 gm of benzene

Vapour pressure of benzene,  $P^\circ = 639.7 \text{ mm}$

Vapour pressure of solution,  $P = 631.9 \text{ mm}$

$$\text{Moles of benzene (Mol. wt. 78), } N = \frac{1000}{78}$$

Moles of solute,  $n = ?$

Substitute these values in the Raoult's equation

$$\frac{P^\circ - P}{P^\circ} = \frac{n}{N} \text{ or } \frac{639.7 - 631.9}{639.7} = \frac{n \times 78}{1000}$$

$$\text{or } \frac{7.8}{639.7} = \frac{78 n}{1000} \quad \therefore n = \frac{1000 \times 7.8}{78 \times 639.7} = \mathbf{0.156}$$

Hence, molality of solution = **0.156 m**

#### 5. The chemical equation for the combustion of organic

compound  $\text{C}_x\text{H}_y\text{O}_z$  can be represented as :

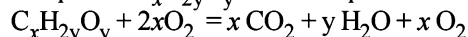

The gases obtained after cooling =  $x + x = 2x$

$$\therefore 2x = 2.24 \text{ litres} \quad [\therefore \text{H}_2\text{O is in liquid state}]$$

$$\text{or } x = \frac{2.24}{2} = 1.12 \text{ litres}$$

$$\text{Number of moles of } \text{CO}_2 = \frac{1.12 \text{ litres}}{22.4 \text{ litres mole}}$$

[ $\therefore$  22.4 L at NTP = 1 mole]

$$= \frac{1}{20} \text{ mole} = 0.05 \text{ mole}$$

## Solutions

The empirical formula of the organic compound is  $C(H_2O)_n$  ... (1)

The mole fraction of the solute (A)  
= relative decrease in vapour pressure of the solvent (B)

$$\frac{p^\circ - p}{p^\circ} = \frac{\frac{W_A}{M_A}}{\frac{W_A}{M_A} + \frac{W_B}{M_B}}$$

$$\text{or } \frac{0.104}{17.5} = \frac{\frac{50}{M_A}}{\frac{50}{M_A} + \frac{1000}{18}} \quad [M_A = \text{mol. wt. g A}]$$

$$\text{or } \frac{0.104}{17.5} = \frac{50}{M_A \left( \frac{50 \times 18 + 1000 M_A}{18 M_A} \right)}$$

$$\text{or } \frac{104}{17500} = \frac{50 \times 18}{900 + 1000 M_A} \quad \text{or } M_A = 150.6$$

Molecular wt. of the organic compound

$(CH_2O)_n = 150$

Molecular wt. of  $CH_2O = 12 + 2 + 16 = 30$

$\therefore 30 \times n = 150 \quad [\because (CH_2O)_n = \text{mol. formula}]$

$$\text{or } n = \frac{150}{30} = 5$$

$\therefore$  Molecular formula of the given organic compound is  $(CH_2O)_5$  or  $C_5H_{10}O_5$ .

6. If they form an ideal solution which obeys Raoult's Law and for which

$\Delta H_{\text{mixing}} = 0$  and  $\Delta V_{\text{mixing}} = 0$

Thus we can separate two volatile and miscible liquids by fractional distillation if, they should not form azeotropic solutions.

7. **TIPS/Formulae :**

$$P_{\text{total}} = p_A + p_B$$

Molecular weight of  $CH_3OH = 12 + 3 + 16 + 1 = 32$

Molecular weight of  $C_2H_5OH = 24 + 5 + 16 + 1 = 46$

According to Raoult's law

$$P_{\text{total}} = p_1 + p_2$$

where  $P_{\text{total}}$  = Total vapour pressure of the solution

$p_1$  = Partial vapour pressure of one component

$p_2$  = Partial vapour pressure of other component

Again,  $p_1 = \text{Vapour pressure } (p_1^\circ) \times \text{mole fraction}$

Similarly,  $p_2 = \text{Vapour pressure } (p_2^\circ) \times \text{mole fraction}$

$$\text{Mole fraction of } CH_3OH = \frac{\frac{40}{32}}{\frac{40}{32} + \frac{60}{46}} = 0.49$$

$$\text{Mole fraction of ethanol} = \frac{\frac{60}{46}}{\frac{60}{46} + \frac{40}{32}} = 0.51$$

**NOTE THIS STEP :** Thus now let us first calculate the partial vapour pressures, i.e.,  $p_1$  and  $p_2$  of the two component.

Partial vapour pressure of  $CH_3OH(p_1)$

$$= 88.7 \times 0.49 = 43.48 \text{ mm}$$

Partial vapour pressure of  $C_2H_5OH(p_2)$

$$= 44.5 \times 0.51 = 22.69 \text{ mm}$$

$\therefore$  Total vapour pressure of the solution

$$= 43.48 + 22.69 \text{ mm} = \mathbf{66.17 \text{ mm}}$$

$$\text{Mole fraction of } CH_3OH \text{ in vapour} = \frac{43.48}{66.17} = \mathbf{0.65}$$

8. **TIPS/Formulae :**

**Molality, M** =  $\frac{\text{moles of solute}}{\text{kg of solvent}}$

**Mole fraction,  $x_A = \frac{n_A}{n_A + n_B}$ ,  $x_B = \frac{n_B}{n_A + n_B}$**

$$p_1 = x_1 p_1^\circ$$

$$\therefore x_1 = \frac{p_1}{p_1^\circ} = \frac{750}{760} = 0.9868$$

$$x_2 (\text{solute}) = 1 - 0.9868 = 0.0132$$

$$\text{Molality, } m = \frac{x_2}{x_1 M_1} \times 1000 = \frac{0.0132 \times 1000}{0.9868 \times 18} = \mathbf{0.7503 \text{ mol kg}^{-1}}$$

9. **TIPS/Formulae :**

According to Raoult's law,

$$\frac{p^\circ - p}{p^\circ} = \frac{w/m}{w/m + W/M}$$

Here,  $p^\circ = 640 \text{ mm}$

$p = 600 \text{ mm}$

$w = 2.175 \text{ g}$

$W = 39.0$

$m = ?$

$M = 78$

Substituting the various values in the above equation for Raoult's law :

$$\frac{640 - 600}{640} = \frac{2.175/m}{2.175/m + 39/78}$$

$$\frac{1}{16} = \frac{2.175}{2.175 + 0.5m} \Rightarrow m = \mathbf{65.25}$$

10. **TIPS/Formulae :** First find moles of  $Ca(NO_3)_2$  and water.

Then use the expression  $\frac{p^\circ - p}{p^\circ} = \frac{n}{n + N}$  to find vapour

pressure of solution.

Let initially 1 mole of  $Ca(NO_3)_2$  is taken

$$\text{Degree of dissociation of } Ca(NO_3)_2 = \frac{70}{100} = 0.7$$

Ionisation of  $Ca(NO_3)_2$  can be represented as



At start 1 0 0

At equilibrium  $1 - 0.7$

0.7

$2 \times 0.7$

$\therefore$  Total number of moles in the solution at equilibrium

$$= (1 - 0.7) + 0.7 + 2 \times 0.7 = 2.4$$

No. of moles when the solution contains 1 gm of calcium nitrate instead of 1 mole of the salt

$$= \frac{2.4}{164} \quad (164 \text{ is the mol. wt. of Cal. nitrate})$$

$\therefore$  No. of moles of the solute in the solution containing 7 g of salt, i.e.,

$$n = \frac{2.4}{164} \times 7 = 0.102$$

$$\text{No. of moles of water (N)} = \frac{\text{Wt. of water}}{\text{Mol. wt. of water}} = \frac{100}{18} = 5.55$$

$$\text{Applying Raoult's law, } \frac{p^0 - p}{p^0} = \frac{n}{n + N}$$

$$\frac{760 - p}{760} = \frac{0.102}{0.102 + 5.55} \Rightarrow \frac{760 - p}{760} = 0.0180$$

$$\Rightarrow p = 760 - (760 \times 0.0180) = \mathbf{746.3 \text{ mm Hg}}$$

### 11. TIPS/Formulae :

Given Wt. of benzene (solvent),

$$W = \text{Volume} \times \text{density} = 50 \times 0.879 = 43.95 \text{ g}$$

Wt. of compound (solute),  $w = 0.643 \text{ g}$

Mol. wt. of benzene,  $M = 78$ ; Mol. wt. of solute,  $m = ?$

Depression in freezing point,  $\Delta T_f = 5.51 - 5.03 = 0.48$

Molal freezing constant,  $K_f = 5.12$

Now we know that,

$$m = \frac{1000 \times K_f \times w}{W \times \Delta T_f} = \frac{1000 \times 5.12 \times 0.643}{43.95 \times 0.48} = \mathbf{156.056}$$

### 12. TIPS/Formulae :

$$\frac{p^0 - p}{p^0} = \frac{\frac{w}{m}}{\frac{w}{m} + \frac{W}{M}}$$

Here,  $w$  and  $m$  are wt. and molecular wt. of solute,  $W$  and  $M$  are wt. and molecular weight of solvent

$p$  = Pressure of solution;  $p^0$  = Normal vapour pressure

Let the initial (normal) pressure ( $p^0$ ) =  $p$

$$\therefore \text{Pressure of solution} = \frac{75}{100} \times p = \frac{3}{4} p$$

$m = 60$ ,  $M = 18$ ,  $W = 100 \text{ gm}$

$$\therefore \frac{p - \frac{3}{4}p}{p} = \frac{\frac{w}{60}}{\frac{w}{60} + \frac{100}{18}} \Rightarrow \frac{1}{4} = \frac{w/60}{(w/60) + 5.55}$$

$$\frac{4w}{60} = \frac{w}{60} + 5.55 \Rightarrow \frac{3w}{60} = \frac{w}{20} = 5.55 \text{ or } w = \mathbf{111 \text{ g}}$$

$$\text{Molality} = \frac{\text{No. of moles of solute}}{\text{Wt. of solvent}} \times 1000$$

$$= \frac{111 \times 1000}{60 \times 100} = \mathbf{18.52 \text{ m}}$$

### 13. TIPS/Formulae :

$$(i) \text{ Volume} = \frac{\text{No. of moles} \times \text{molar mass}}{\text{density}}$$

$$(ii) PV = nRT \text{ or } P = \frac{nRT}{V}$$

$$\text{Volume of 1 mole of liq. benzene} = \frac{78}{0.877}$$

$$\text{Volume of 1 mole of toluene} = \frac{92}{0.867}$$

In vapour phase,

At  $20^\circ\text{C}$ , for 1 mole of benzene,

$$\text{Volume} = \frac{1 \times 78 \times 2750}{0.877} = 244583.80 \text{ mL} = 244.58 \text{ L}$$

Similarly for 1 mole of toluene,

$$\text{volume} = \frac{1 \times 92}{0.867} \times 7720 = 819192.61 \text{ mL} = 819.19 \text{ L}$$

As we know that,  $PV = nRT$

$$\text{For benzene, } P_B^0 = \frac{nRT}{V} = \frac{1 \times 0.0821 \times 293}{244.58} \text{ atm} = 0.098 \text{ atm}$$

$$\text{For toluene, } P_T^0 = \frac{nRT}{V} = \frac{1 \times 0.0825 \times 293}{819.19} \text{ atm} = 0.029 \text{ atm}$$

$$P = P_B^0 \cdot X_B + P_T^0 \cdot X_T$$

$$\therefore X_B + X_T = 1 \quad \therefore X_T = 1 - X_B$$

$$P = P_B^0 \cdot X_B + P_T^0 (1 - X_B)$$

$$\text{Total vapour-pressure} = 46 \text{ torr} = \frac{46}{760} = 0.060 \text{ atm}$$

$$\text{Thus, } 0.060 = 0.098 X_B + 0.029 (1 - X_B)$$

$$\Rightarrow 0.060 = 0.098 X_B + 0.029 - 0.029 X_B \Rightarrow 0.031 = 0.069 X_B$$

$$\therefore X_B = \frac{0.031}{0.069} = 0.45 \text{ (in liquid phase)}$$

$$X_B + X_T = 1$$

$$X_T = 1 - 0.45 = 0.55 \text{ (in liquid phase)}$$

$$\text{Also, } P_B' = P_B^0 X_B = P X_B'$$

$$\text{So, } 0.098 \times 0.45 = 0.060 \times X_B'$$

$$X_B' = \frac{0.098 \times 0.45}{0.060} = \mathbf{0.735 \text{ (in gas phase)}}$$

### 14. TIPS/Formulae :

$$\Delta T_f = K_f \cdot m$$

$$\frac{P^0 - p}{p^0} = \frac{\text{moles of solute}}{\text{moles of solvent}}$$

Depression in freezing point,  $\Delta T_f = 0 - (-0.30) = 0.30$

Now we know that  $\Delta T_f = K_f m$

$$\therefore m = \frac{\Delta T_f}{K_f} = \frac{0.30}{1.86} = 0.161$$



## Solutions

According to Raoult's law

$$\frac{p^\circ - p}{p^\circ} = \frac{\text{No. of moles of solute}}{\text{No. of moles of solvent}}$$

$$\frac{23.51 - p}{23.51} = \frac{0.161}{1000/18} = \frac{0.161 \times 18}{1000}$$

$$\left( \because \text{No. of moles of H}_2\text{O} = \frac{1000}{18} \right)$$

On usual calculations,

$$\frac{23.51 - p}{23.51} = 0.0020898$$

$$p = 23.51 - 23.51 \times 0.0020898 = 23.51 - .068$$

$$p = 23.44 \text{ mm Hg}$$

15. TIPS/Formulae:  $\Delta T_b = k_b \times m$

Element	%	Relative no. of atoms	Simplest ratio
C	42.86	$\frac{42.86}{12} = 3.57$	$\frac{3.57}{1.19} = 3$
H	2.40	$\frac{2.40}{1} = 2.40$	$\frac{2.40}{1.19} = 2$
N	16.67	$\frac{16.67}{14} = 1.19$	$\frac{1.19}{1.19} = 1$
O	38.07	$\frac{38.07}{16} = 2.38$	$\frac{2.38}{1.19} = 2$

$\therefore$  Empirical formula of the minor product is  $\text{C}_3\text{H}_2\text{NO}_2$

Molar empirical formula mass of the minor product  
 $= 3 \times 12 + 2 \times 1 + 1 \times 14 + 2 \times 16 = 84 \text{ g mol}^{-2}$

Let  $M$  be the molar mass of the minor product. For 5.5 g of the minor product dissolved in 45 g benzene, the molality

$$(m) \text{ of the solution} = \frac{5.5 \text{ g/M}}{0.045 \text{ kg}}$$

Substituting this in the expression of elevation of boiling point,

$$\Delta T_b = K_b m \Rightarrow 1.84 \text{ K} = (2.53 \text{ K kg mol}^{-1}) \left( \frac{5.5 \text{ g/M}}{0.045 \text{ kg}} \right)$$

$$\text{or } M = 168 \text{ g mol}^{-1}$$

No. of unit of empirical formula in molecular formula

$$= \frac{168 \text{ g mol}^{-1}}{84 \text{ g F}} = 2$$

Hence the molecular formula of the minor product is  $2(\text{C}_3\text{H}_2\text{NO}_2)$ , i.e.,  $\text{C}_6\text{H}_4(\text{NO}_2)_2$ .



16. TIPS/Formulae:

$$\Delta T_f = i \times K_f \times m$$

$$\text{Weight of water} = 500 \times 0.997 = 498.5 \text{ g} \quad (\text{weight} = \text{volume} \times \text{density})$$

No. of moles of acetic acid

$$= \frac{\text{Wt. of CH}_3\text{COOH in g}}{\text{Mol. wt. of CH}_3\text{COOH}} = \frac{3 \times 10^{-3} \times 10^3}{60} = 0.05$$

Since 498.5 g of water has 0.05 moles of  $\text{CH}_3\text{COOH}$

$$1000 \text{ g of water has} = \frac{0.05 \times 1000}{498.5} = 0.1$$

Therefore molality of the solution = 0.1

**Determination of van't Hoff factor,  $i$**

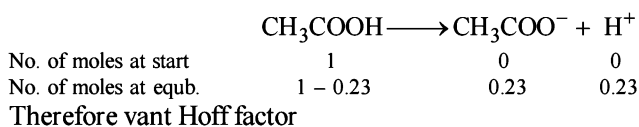

$$= \frac{\text{No. of particles before dissociation}}{\text{No. of particles after dissociation}}$$

$$= \frac{1 - 0.23 + 0.23 + 0.23}{1} = 1.23$$

Now we know that

$$\Delta T_f = i \times K_f \times m = 1.23 \times 1.86 \times 0.1 = 0.228 \text{ K}$$

17. (i) TIPS/Formulae:

$$\Delta T_b = K_b \times M$$

In first case,

$$\Delta T_b = K_b \times m = K_b \times \frac{\text{Wt. of solute}}{\text{Mol. wt. of solute}}$$

$$\text{or } 0.17 = 1.7 \times \frac{1.22}{M \times 100 \times 10^{-3}} \text{ or } M = 122$$

Thus the benzoic acid exists as a monomer in acetone

(ii) In second case,

$$\Delta T_b = K_b \times \frac{\text{Wt. of solute}}{\text{Mol. wt. of solute}}$$

$$\text{or } 0.13 = 2.6 \times \frac{1.22}{M' \times 100 \times 10^{-3}} \Rightarrow M' = 224$$

**NOTE:** Double the expected molecular weight of benzoic acid (244) in acetone solution indicates that benzoic acid exists as a dimer in acetone.

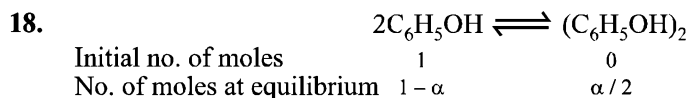

$$\text{Total number of moles at equilibrium} = 1 - \alpha + \frac{\alpha}{2} = 1 - \frac{\alpha}{2}$$

$$\Delta T_f = i K_f \times (\text{molality})$$

$$\Rightarrow 7 = 14 \times \frac{75.2}{94} \times \left( 1 - \frac{\alpha}{2} \right) \left[ \begin{array}{l} \text{weight of phenol} = 75.2 \text{ g} \\ \text{mol. wt. of phenol} = 94 \end{array} \right]$$

$$\therefore \alpha = 0.75$$

So the percentage of phenol that dimerises = 75%.

### G. Comprehension Based Questions

1. (d) The solution M is a mixture of ethanol and water. In it the mole fraction of ethanol is 0.9 and mole fraction of water is 0.1 ( $1.0 - 0.9 = 0.1$ ) Also given are:-

Standard freezing point of ethanol = 155.7K.

Freezing point depression constant

( $K_f$ ) for ethanol =  $2.0 \text{ kg mol}^{-1}$

Molecular weight of ethanol ( $\text{C}_2\text{H}_5\text{OH}$ ) = 46

$$\text{now molality (m) of solution} = \frac{0.1 \times 1000}{0.9 \times 46}$$

Using the formula :-

Depression in freezing point ( $\Delta T_f$ ) =  $K_f \times m$ ,

Substituting various values, we get

$$\Delta T_f = \frac{2 \times 0.1 \times 1000}{0.9 \times 46} = \frac{2000}{414} = 4.83 \text{ K.}$$

$$\therefore \text{Freezing point of solution 'M'} = (155.7 - 4.83) \text{ K} \\ = 150.9 \text{ K}$$

i.e. (d) is the correct answer.

2. (b) **Given:** vapour pressure of pure ethanol ( $P_A^0$ ) = 40 mmHg  
Mole fraction ( $X_A$ ) of ethanol in solution = 0.9

Using the formula: Total pressure ( $P$ ) =  $P_A^0 X_A^0$

Substituting the given values, we get

$$P = 40 \times 0.9 = 36.0 \text{ mm Hg}$$

i.e. (b) is the correct answer.

3. (b) **Given:** Standard boiling point of water = 373K

Boiling point elevation constant of water ( $K_b$ ) =  $0.52 \text{ Kg mol}^{-1}$

Molecular weight of water ( $\text{H}_2\text{O}$ ) = 18

Mole fraction of water in solution = 0.1 ( $1.0 - 0.9 = 0.1$ )

$$\text{molality (m)} = \frac{0.1 \times 1000}{0.9 \times 18}$$

using the relation  $\Delta T_b = K_b \times m$

Substituting the given values, we get

$$\Delta T_b = 0.52 \times \frac{0.1 \times 1000}{0.9 \times 18} = \frac{520}{9 \times 18} = 3.20 \text{ K}$$

$$\therefore \text{Boiling point of solution} = (373 + 3.20) \text{ K} \\ = 376.2 \text{ K}$$

i.e. option (b) is correct answer.

#### I. Interger Value Correct Type

1. (8) Molarity of stock solution of HCl

$$= \frac{29.2 \times 1000 \times 1.25}{100 \times 36.5}$$

Let the volume of stock solution required =  $V \text{ mL}$

$$\text{Thus, } V \times \frac{29.2 \times 1000 \times 1.25}{100 \times 36.5} = 200 \times 0.4 = 8 \text{ mL}$$

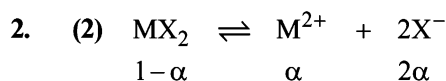

$$i = \frac{\text{observed depression in f.pt of aq. solution}}{\text{depression of f.p.t. in absence of ionic dissociation}}$$

$$= \frac{1 - \alpha + \alpha + 2\alpha}{1} = 1 + 2\alpha = 1 + 2 \times 0.5 = 2$$

3. (8)

$$\text{Molality} = \frac{\text{wt. of solute in 1 L of solution} \times 1000}{\text{wt. of solvent in 1 L of solution} \times \text{mol. wt. of solute}}$$

Calculation of wt. of solvent

1 mL of solvent = 0.4 g

1000 mL of solvent = 400 g

Calculation of wt. of solute

1000 mL of solution contain =  $3.2 \times 80 \text{ g solute} = 256 \text{ g}$

$$\therefore \text{Molality} = \frac{256 \times 1000}{400 \times 80} = 8$$

4. (1) Given  $\Delta T_f = 0.0558^\circ\text{C}$   
as we know,  $\Delta T_f = i \times K_f \times m$

$$\Rightarrow 0.0558 = i \times 1.86 \times 0.01$$

$$\boxed{i = 3}$$

Therefore the complex will be  $[\text{Co}(\text{NH}_3)_5\text{Cl}]\text{Cl}_2$

Hence number of chloride in co-ordination sphere is 1.

5. (9) 1 mole solution has 0.1 mole solute and 0.9 mole solvent.

Let  $M_1$  = Molar mass solute

$M_2$  = Molar mass solvent

$$\text{Molality, } m = \frac{0.1}{0.9M_2} \times 1000 \quad \dots\dots (1)$$

$$\text{Molarity, } M = \frac{0.1}{0.1M_1 + 0.9M_2} \times 2 \times 1000 \quad \dots\dots (2)$$

$$\therefore m = M$$

$$\Rightarrow \frac{0.1 \times 1000}{0.9M_2} = \frac{200}{0.1M_1 + 0.9M_2}$$

$$\Rightarrow \frac{M_1}{M_2} = 9$$

## Section-B

# JEE Main/ AIEEE

1. (b)  $\Delta T_b = K_b \frac{W_B}{M_B \times W_A} \times 1000$ ;  
 $\Delta T_f = K_f \frac{W_B}{M_B \times W_A} \times 1000$ ;  
 $\frac{\Delta T_b}{\Delta T_f} = \frac{K_b}{K_f} = \frac{\Delta T_b}{-0.186} = \frac{0.512}{1.86} = 0.0512^\circ\text{C}$ .
2. (d) In solution containing A and B component showing negative deviation A-A and B-B interactions are weaker than that of A-B interactions. For such solutions.  
 $\Delta H = -ve$  and  $\Delta V = -ve$
3. (d) When A and B form an ideal solution,  $\Delta H_{\text{mix}} = 0$
4. (d)  $\Delta T_f = K_f \times m \times i$ ;  
 $\Delta T_f = 1.85 \times 0.2 \times 1.3 = 0.480^\circ\text{C}$   
 $\therefore T_f = 0 - 0.480^\circ\text{C} = -0.480^\circ\text{C}$   
 $(HX \rightleftharpoons \overset{+}{H} + \overset{-}{X}, i = 1.3)$
5. (a) **NOTE** : On increasing pressure, the temperature is also increased. Thus in pressure cooker due to increase in pressure the b.p. of water increases.
6. (c)  $\therefore \Delta T_b^\circ = T_b - T_b^\circ$   
 Where  $T_b$  = b.pt of solution  
 $T_b^\circ$  = b.pt of solvent or  $T_b = T_b^\circ + \Delta T_b$   
**NOTE** : Elevation in boiling point is a colligative property, which depends upon the no. of particles. Thus greater the number of particles, greater is its elevation and hence greater will be its boiling point.  
 $\text{Na}_2\text{SO}_4 \rightleftharpoons 2\text{Na}^+ + \text{SO}_4^{2-}$   
 Since  $\text{Na}_2\text{SO}_4$  has maximum number of particles (3) hence has maximum boiling point.
7. (d) Gaseous densities of ethanol and dimethyl ether would be same at same temperature and pressure. The heat of vaporisation, V.P. and b.pts will differ due to H-bonding in ethanol.
8. (b) **NOTE** : Positive deviations are shown by such solutions in which solvent-solvent and solute-solute interactions are stronger than the solvent interactions. In such solution, the interactions among molecules becomes weaker. Therefore their escaping tendency increases which results in the increase in their partial vapour pressures.  
 In a solutions of benzene and methanol there exists inter molecular H-bonding.  
 $\cdots \cdots \text{O} - \text{H} \cdots \cdots \text{O} - \text{H} \cdots \cdots \text{O} - \text{H} \cdots \cdots$   
 $\quad \quad \quad | \quad \quad \quad | \quad \quad \quad |$   
 $\quad \quad \quad \text{C}_2\text{H}_5 \quad \text{C}_2\text{H}_5 \quad \text{C}_2\text{H}_5$   
 In this solution benzene molecules come between ethanol molecules which weaken intermolecular forces. This results in increase in vapour pressure.
9. (d)  $\Delta T_f = K_f \times m \times i$ . Since  $K_f$  has different values for different solvents, hence even if the  $m$  is the same  $\Delta T_f$  will be different

10. (d) Given, Vapour pressure of benzene = 75 torr  
 Vapour pressure of benzene = 22 torr  
 mass of benzene in = 78g  
 hence moles of benzene =  $\frac{78}{78} = 1$  mole  
 (mol. wt of benzene = 78)  
 mass of toluene in solution = 46g  
 hence moles of toluene =  $\frac{46}{92} = 0.5$  mole  
 now partial pressure of benzene  
 $= P_b^\circ X_b = 75 \times \frac{1}{1+0.5} = 50 \text{ torr} = 75 \times \frac{1}{1.5} = 75 \times \frac{2}{3} = 50$
11. (d) Equimolar solutions of normal solutes in the same solvent will have the same b. pts and same f. pts.
12. (d) Acetonitrile ( $\overset{\delta+}{\text{C}}\text{H}_3 - \text{C} \equiv \overset{\delta-}{\text{N}}$ ) and acetone  
 $\begin{array}{l} \delta+ \\ (\text{CH}_3) \\ \delta- \\ (\text{CH}_3) \end{array} \text{C} = \overset{\delta-}{\text{O}}$  both are polar molecules, hence dipole-dipole interaction exist between them. Between KCl and water ion-dipole interaction is found and in Benzene ethanol and Benzene-Carbon tetra chloride dispersion force is present
13. (b) Moles of glucose =  $\frac{18}{180} = 0.1$   
 Moles of water =  $\frac{178.2}{18} = 9.9$   
 Total moles =  $0.1 + 9.9 = 10$   
 $P_{\text{H}_2\text{O}} = \text{Mole fraction} \times \text{Total pressure} = \frac{9.9}{10} \times 760$   
 $= 752.4 \text{ Torr}$
14. (b)  $p_A^\circ = ?$ , Given  $p_B^\circ = 200 \text{ mm}$ ,  $x_A = 0.6$ ,  
 $x_B = 1 - 0.6 = 0.4$ ,  $P = 290$   
 $P = p_A + p_B = p_A^\circ x_A + p_B^\circ x_B$   
 $\Rightarrow 290 = p_A^\circ \times 0.6 + 200 \times 0.4 \quad \therefore p_A^\circ = 350 \text{ mm}$
15. (d) Let the mass of methane and oxygen =  $m$  gm.  
 Mole fraction of  $\text{O}_2$   
 $= \frac{\text{Moles of } \text{O}_2}{\text{Moles of } \text{O}_2 + \text{Moles of } \text{CH}_4}$   
 $= \frac{m/32}{m/32 + m/16} = \frac{m/32}{3m/32} = \frac{1}{3}$   
 Partial pressure of  $\text{O}_2 = \text{Total pressure} \times \text{mole fraction of } \text{O}_2$ ,  $P_{\text{O}_2} = P \times \frac{1}{3} = \frac{1}{3}P$

## 16. (a) TIPS/FORMULAE:

Osmotic pressure ( $\pi$ ) of isotonic solutions are equal.

For solution of unknown substance ( $\pi = CRT$ )

$$C_1 = \frac{5.25/M}{V}$$

For solution of urea,  $C_2$  (concentration) =  $\frac{1.5/60}{V}$

Given,  $\pi_1 = \pi_2$   $\therefore \pi = CRT$

$$\therefore C_1 RT = C_2 RT \text{ or } C_1 = C_2 \text{ or } \frac{5.25/M}{V} = \frac{1.8/60}{V}$$

$$\therefore M = 210 \text{ g/mol}$$

## 17. (d) At 1 atmospheric pressure the boiling point of mixture is 80°C.

At boiling point the vapour pressure of mixture,  $P_T = 1$  atmosphere = 760 mm Hg.

Using the relation,

$$P_T = P_A^0 X_A + P_B^0 X_B, \text{ we get}$$

$$P_T = 520 X_A + 1000(1 - X_A)$$

$$\{ \because P_A^0 = 520 \text{ mm Hg,}$$

$$P_B^0 = 1000 \text{ mm Hg, } X_A + X_B = 1 \}$$

$$\text{or } 760 = 520 X_A + 1000 - 1000 X_A \text{ or } 480 X_A = 240$$

$$\text{or } X_A = \frac{240}{480} = \frac{1}{2} \text{ or } 50 \text{ mol. percent}$$

i.e., The correct answer is (d)

## 18. (a) NOTE : On addition of glucose to water, vapour pressure of water will decrease. The vapour pressure of a solution of glucose in water can be calculated using the relation

$$\frac{P^0 - P_s}{P_s} = \frac{\text{Moles of glucose in solution}}{\text{moles of water in solution}}$$

$$\text{or } \frac{17.5 - P_s}{P_s} = \frac{18/180}{178.2/18} \quad [\because P^0 = 17.5]$$

$$\text{or } 17.5 - P_s = \frac{0.1 \times P_s}{9.9} \text{ or } P_s = 17.325 \text{ mm Hg.}$$

Hence (a) is correct answer.

19. (b) For this solution intermolecular interactions between *n*-heptane and ethanol are weaker than *n*-heptane - *n*-heptane & ethanol-ethanol interactions hence the solution of *n*-heptane and ethanol is non-ideal and shows positive deviation from Raoult's law.

$$20. (b) P_{\text{total}} = P_A^0 X_A + P_B^0 X_B; 550 = P_A^0 \times \frac{1}{4} + P_B^0 \times \frac{3}{4}$$

$$P_A^0 + 3P_B^0 = 550 \times 4 \dots (i)$$

In second case

$$P_{\text{total}} = P_A^0 \times \frac{1}{5} + P_B^0 \times \frac{4}{5}$$

$$P_A^0 + 4P_B^0 = 560 \times 5 \dots (ii)$$

Subtract (i) from (ii)

$$\therefore P_B^0 = 560 \times 5 - 550 \times 4 = 600 \quad \therefore P_A^0 = 400$$

## 21. (b) Sodium sulphate dissociates as

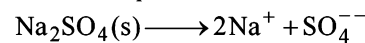

hence van't Hoff factor  $i = 3$

$$\text{Now } \Delta T_f = i k_f m = 3 \times 1.86 \times 0.01 = 0.0558 \text{ K}$$

$$22. (a) P_{\text{Total}} = P_A^0 x_A + P_B^0 x_B$$

$$= P_{\text{Heptane}}^0 x_{\text{Heptane}} + P_{\text{Octane}}^0 x_{\text{Octane}}$$

$$= 105 \times \frac{25/100}{\frac{25}{100} + \frac{35}{114}} + 45 \times \frac{35/114}{\frac{25}{100} + \frac{35}{114}}$$

$$= 105 \times \frac{0.25}{0.25 + 0.3} + 45 \times \frac{0.3}{0.25 + 0.3}$$

$$= \frac{105 \times 0.25}{0.55} + \frac{45 \times 0.3}{0.55} = \frac{26.25 + 13.5}{0.55} = 72 \text{ kPa}$$

## 23. (c) 5.2 molal solution means 5.2 moles of methyl alcohol in

1000 gm water or in  $\frac{1000}{18}$  mole of water.

$\therefore$  mole fraction of methyl alcohol

$$= \frac{\text{moles of methyl alcohol}}{\text{moles of methyl alcohol} + \text{moles of water}}$$

$$= \frac{5.2}{5.2 + \frac{1000}{18}} = 0.086$$

24. (a) Given  $K_f = 1.86 \text{ K kg mol}^{-1}$ 

$$\Delta T_f = 0 - (-6) = 6^\circ\text{C}$$

As we know that

$$\Delta T_f = K_f \times \text{molality}$$

$$= \frac{K_f \times 1000 \times \text{mass of solute}}{\text{molar mass of solute} \times \text{mass of solvent in kg}}$$

Substituting given values in formula

$$6 = \frac{1.86 \times 1000 \times w}{62 \times 4}; w = 0.8 \text{ kg} = 800 \text{ gm}$$

25. (a)  $A_x B_y \rightleftharpoons xA^{y+} + yB^{x-}$ 

$$t = 0 \quad 1 \quad 0 \quad 0$$

$$t_{\text{eq}} \quad 1 - \alpha \quad x\alpha \quad y\alpha$$

$$\text{Total no. of moles (i)} = 1 - \alpha + x\alpha + y\alpha$$

$$i - 1 = x\alpha + y\alpha - \alpha = \alpha(x + y - 1)$$

$$\therefore \alpha = \frac{i - 1}{(x + y - 1)}$$

26. (d) Molarity =  $\frac{\text{moles of solute}}{\text{volume of solution}(\ell)}$ 

$$\text{Mass of solution} = 1000 + 120 = 1120$$

$$d = \frac{M}{v}; v = \frac{M}{d} = \frac{1120}{1.15} \text{ mL} = \frac{120 \times 1.15}{60 \times 1120} \times 1000 = 2.05 \text{ M}$$

## Solutions

27. (b)  $\Delta T_f = i \times K_f \times m$

Given  $\Delta T_f = 2.8$ ,  $K_f = 1.86 \text{ K kg mol}^{-1}$   $i = 1$

(ethylene glycol is a non-electrolyte)

wt. of solvent = 1 kg; Let wt of solute =  $x$

Mol. wt of ethylene glycol = 62

$$2.8 = 1 \times 1.86 \times \frac{x}{62 \times 1} \text{ or } x = \frac{2.8 \times 62}{1.86} = 93 \text{ gm}$$

28. (a) From Molarity equation :

$$M_1 V_1 + M_2 V_2 = M \times V$$

$$M = \frac{M_1 V_1 + M_2 V_2}{V} \text{ where } V = \text{total volume}$$

$$= \frac{750 \times 0.5 + 250 \times 2}{1000} = 0.875 \text{ M}$$

29. (a)  $\pi = i CRT$

$$\pi_{\text{C}_2\text{H}_5\text{OH}} = 1 \times 0.500 \times R \times T = 0.5 RT$$

$$\pi_{\text{Mg}_3(\text{PO}_4)_2} = 5 \times 0.100 \times R \times T = 0.5 RT$$

$$\pi_{\text{KBr}} = 2 \times 0.250 \times R \times T = 0.5 RT$$

$$\pi_{\text{Na}_3\text{PO}_4} = 4 \times 0.125 \times RT = 0.5 RT$$

Since the osmotic pressure of all the given solutions is

equal. Hence all are isotonic solution.

30. (d) Using relation,

$$\frac{p^\circ - p_s}{p_s} = \frac{w_2 M_1}{w_1 M_2}$$

where  $w_1$ ,  $M_1$  = mass in g and mol. mass of solvent

$w_2$ ,  $M_2$  = mass in g and mol. mass of solute

Let  $M_2 = x$

$$p^\circ = 185 \text{ torr}; p_s = 183 \text{ torr}$$

$$\frac{185 - 183}{183} = \frac{1.2 \times 58}{100x} \text{ (Mol. mass of acetone = 58)}$$

$$x = 64$$

$\therefore$  Molar mass of substance = 64

31. (a) According to Raoult's Law

$$\frac{P^\circ - P_s}{P_s} = \frac{W_B \times M_A}{M_B \times W_A} \quad \dots (i)$$

Here  $P^\circ$  = Vapour pressure of pure solvent,

$P_s$  = Vapour pressure of solution

$W_B$  = Mass of solute,  $W_A$  = Mass of solvent

$M_B$  = Molar mass of solute,  $M_A$  = Molar Mass of solvent

Vapour pressure of pure water at  $100^\circ \text{C}$  (by assumption = 760 torr)

By substituting values in equation (i) we get,

$$\frac{760 - P_s}{P_s} = \frac{18 \times 18}{180 \times 178.2} \quad \dots (ii)$$

On solving (ii) we get

$$P_s = 752.4 \text{ torr}$$

## Section-A : JEE Advanced/ IIT-JEE

- A** 1.  $I^-$       2. negative, greater      3. increased
- B** 1. F
- C** 1. (a)    2. (c)    3. (c)    4. (d)    5. (c)    6. (a)    7. (a)    8. (a)    9. (c)  
10. (a)    11. (b)    12. (c)    13. (b)    14. (a)    15. (c)    16. (b)    17. (a)    18. (b)  
19. (d)    20. (d)    21. (d)
- D** 1. (a)    2. (a,b,c)    3. (a)
- E** 1. 27171.96 coulombs      2. (a) 71.34 : 1, (c)  $2.06 \times 10^4$  coulombs  
4. (ii) 1.113 volts, (iii) spontaneous      5. 4.7625 g, 0.8042 A  
6. 125.09 sec      7. 8.62      8. 265.02 Ah      9. 19.06 g  
10.  $10^{-4}$  M      11. 643.3 A, 190.50 g      12. 99.79 ml, 58.48 ml      13.  $9.88 \times 10^{-15}$   
14.  $1.48 \times 10^{-9}$  M      15. 115800 C, 347.4 kJ      16.  $5.128 \times 10^{-18} \text{ mol l}^{-1}$       17. 0.154 M  
18.  $-0.037$  V      19. 48.69 hrs., 1.408 M      20. (i) 0.887 V, (ii) 0.046 V      21. (i) 2.1554 g of Cr, (ii) 1336.15 sec  
22. 0.325 V,  $-0.149$  V      23. (ii) 1.27 V, (iii)  $2.45 \times 10^5$  J      24. 0.792 V      25.  $-0.22$  V  
27. 34.02 g, 1275.6  $\text{cm}^2$       28.  $7.6 \times 10^{12}$       29.  $6.26 \times 10^7$       30.  $2.44 \times 10^{-12}$   
31. 0.010 V      32.  $7.95 \times 10^{-5} \text{ mol l}^{-1}$       33. Ce electrode to iron electrode, decrease  
34. (ii)  $-22195$  J/mole,  $-49987$  J/mole; (iii)  $1.24 \times 10^{-5} \text{ mol/L}$       35. 0.05 M  
36.  $10^{10}$       37. (a) 0.59 V,  $10^{-10}$  (b)  $52.9, 10^{-6}$       38. 55
- F** 1. (A - p, s); (B - r); (C - p, q); (D - p).  
2. (a)  
3. (d)
- G** 1. (d)    2. (a)    3. (b)    4. (b)    5. (d)    6. (d)    7. (c)    8. (d)    9. (a)  
10. (b)    11. (c)    12. (d)    13. (b)
- I** 1. 4    2. 3

## Section-B : JEE Main/ AIEEE

1. (b)    2. (c)    3. (b)    4. (a)    5. (d)    6. (d)    7. (c)  
8. (d)    9. (a)    10. (b)    11. (b)    12. (b)    13. (a)    14. (a)  
15. (c)    16. (a)    17. (c)    18. (d)    19. (a)    20. (d)    21. (b)  
22. (c)    23. (b)    24. (b)    25. (b)    26. (d)    27. (d)    28. (c)  
29. (b)    30. (c)    31. (a)    32. (c)    33. (d)    34. (d)    35. (a)  
36. (a)    37. (c)    38. (d)    39. (b)

## Section-A JEE Advanced/ IIT-JEE

## A. Fill in the Blanks

1.  $I^-$  ( $\because I_2$  is weakest oxidising agent)
2. **negative, greater;** Among the various metals, since sodium has the minimum reduction potential, it must be strongest reducing agent. In general, more the reduction potential lesser is its reducing action.
3. **increased;**

## B. True/False

1. **False :** When the temperature is 273, the value of the factor will come out as 0.0541 instead of 0.0591. The value 0.0591 comes out at 298 K and not at 273 K.

## C. MCQs with One Correct Answer

1. (a) More negative is the value of reduction potential, higher will be the reducing property, i.e., the power to give up electrons.
2. (c)  $\frac{W_1}{W_2} = \frac{E_1}{E_2} = \frac{Z_1}{Z_2} \frac{it}{it} \quad \therefore \frac{Z_1}{Z_2} = \frac{E_1}{E_2}$   
Here  $E_1$  &  $E_2$  are equivalent weights of the ions.
3. (c) The reduction potentials (as given) of the ions are in the order :  
 $Ag^+ > Hg_2^{2+} > Cu^{2+} > Mg^{2+}$   
 $Mg^{2+}$  (aq.) will not be reduced as its reduction potential is much lower than that of water ( $-0.83$  V).  
Hence the sequence of deposition of the metals will be Ag, Hg, Cu.

4. (d) Charge of one mole of electrons = 96500 C  $\therefore$  1 mole gram equivalent of substance will be deposited by one mole of electrons.
5. (c) **NOTE** : Oxidation is loss of electron and in a galvanic cell it occurs at anode. Reduction is gain of electron and in a galvanic cell it occurs at cathode.  
**Cell representation** :  
Anode/Anodic electrolyte || Cathodic electrolyte/Cathode  
Reaction at Anode :  $\text{H}_2 \rightarrow 2\text{H}^+ + 2\text{e}^-$   
Reaction at Cathode :  $\text{AgCl} + \text{e}^- \rightarrow \text{Ag} + \text{Cl}^-$
6. (a) Water is reduced at the cathode and oxidized at the anode instead of  $\text{Na}^+$  and  $\text{SO}_4^{2-}$ .  
**Cathode** :  $2\text{H}_2\text{O} + 2\text{e}^- \rightarrow \text{H}_2 + 2\text{OH}^-$   
**Anode** :  $\text{H}_2\text{O} \rightarrow 2\text{H}^+ + \frac{1}{2}\text{O}_2 + 2\text{e}^-$
7. (b) **TIPS/FORMULAE** :  
(i) In a galvanic cell oxidation occurs at anode and reduction occurs at cathode.  
(ii) Oxidation occurs at electrode having higher oxidation potential and it behaves as anode and other electrode acts as cathode.  
(iii)  $E_{\text{cell}} = E_{\text{C}} - E_{\text{A}}$   
(substitute reduction potential at both places).  
 $\text{Fe}^{2+} + \text{Zn} \rightarrow \text{Zn}^{2+} + \text{Fe}$   
 $\therefore \text{Zn} \rightarrow \text{Zn}^{2+} + 2\text{e}^-$  and  $\text{Fe}^{2+} + 2\text{e}^- \rightarrow \text{Fe}$   
 $\therefore$  Zn is anode and Fe is cathode.  
 $E_{\text{cell}} = E_{\text{C}} - E_{\text{A}} = -0.41 - (-0.76) = 0.35\text{V}$
8. (a)  $\text{H}_2\text{O}$  is more readily reduced at cathode than  $\text{Na}^+$ . It is also more readily oxidized at anode than  $\text{SO}_4^{2-}$ . Hence, the electrode reactions are  
 $2\text{H}_2\text{O} + 2\text{e}^- \rightarrow \text{H}_2 \uparrow + 2\text{OH}^-$  [at cathode]  
 $\text{H}_2\text{O} \rightarrow \frac{1}{2}\text{O}_2 \uparrow + 2\text{H}^+ + 2\text{e}^-$  [at anode]
9. (c) We have
- | Half-cell                      | Half-cell reaction                          | $\Delta G^\circ = -nFE^\circ$                               |
|--------------------------------|---|---|
| $\text{Cu}^{2+}   \text{Cu}$   | $\text{Cu}^{2+} + 2\text{e}^- = \text{Cu}$  | $\Delta G_1^\circ = -2FE_{\text{Cu}^{2+} \text{Cu}}^\circ$  |
| $\text{Cu}^{2+}   \text{Cu}^+$ | $\text{Cu}^{2+} + \text{e}^- = \text{Cu}^+$ | $\Delta G_2^\circ = -FE_{\text{Cu}^{2+} \text{Cu}^+}^\circ$ |
| $\text{Cu}^+   \text{Cu}$      | $\text{Cu}^+ + \text{e}^- = \text{Cu}$      | $\Delta G_3^\circ = -FE_{\text{Cu}^+ \text{Cu}}^\circ$      |
- From the half-cell reactions, it follows that  
 $\Delta G_3^\circ = \Delta G_1^\circ - \Delta G_2^\circ$   
i.e.,  
 $-FE_{\text{Cu}^+|\text{Cu}}^\circ = -2FE_{\text{Cu}^{2+}|\text{Cu}}^\circ - (-FE_{\text{Cu}^{2+}|\text{Cu}^+}^\circ)$   
or  $E_{\text{Cu}^+|\text{Cu}}^\circ = 2E_{\text{Cu}^{2+}|\text{Cu}}^\circ - E_{\text{Cu}^{2+}|\text{Cu}^+}^\circ$   
 $= 2(0.337\text{V}) - 0.153\text{V} = 0.521\text{V}$
10. (a) The given order of reduction potentials is  $Z > Y > X$ . A spontaneous reaction will have the following characteristics  
Z reduced and Y oxidised  
Z reduced and X oxidised  
Y reduced and X oxidised  
Hence, Y will oxidise X and not Z.
11. (b) For  $\text{M}^+ + \text{X}^- \rightarrow \text{M} + \text{X}$ ,  $E_{\text{cell}}^\circ = 0.44 - 0.33 = 0.11\text{V}$  is positive, hence reaction is spontaneous.
12. (c) The salt used to make 'salt-bridge' must be such that the ionic mobility of cation and anion are of comparable order so that they can keep the anode and cathode half cells neutral at all times.  $\text{KNO}_3$  is used because velocities of  $\text{K}^+$  and  $\text{NO}_3^-$  ions are nearly same
13. (b) As we go down the group 1 (i.e. from  $\text{Li}^+$  to  $\text{K}^+$ ), the ionic radius increases, degree of solvation decreases and hence effective size decreases resulting in increase in ionic mobility. Hence equivalent conductance at infinite dilution increases in the same order.
14. (a)  $\text{MnO}_4^-$  will oxidise  $\text{Cl}^-$  ion according to the following equation  
 $2\text{MnO}_4^- + 16\text{H}^+ + 10\text{Cl}^- \rightarrow 2\text{Mn}^{2+} + 8\text{H}_2\text{O} + 5\text{Cl}_2 \uparrow$   
The cell corresponding to this reaction is as follows :  
 $\text{Pt}, \text{Cl}_2 (1\text{ atm}) | \text{Cl}^- || \text{MnO}_4^-, \text{Mn}^{2+}, \text{H}^+ | \text{Pt}$   
 $E_{\text{cell}}^\circ = 1.51 - 1.40 = 0.11\text{V}$   
 $E_{\text{cell}}^\circ$  being +ve,  $\Delta G^\circ$  will be -ve and hence the above reaction is feasible.  $\text{MnO}_4^-$  will not only oxidise  $\text{Fe}^{2+}$  ion but also  $\text{Cl}^-$  ion simultaneously. So the quantitative estimation of aq  $\text{Fe}(\text{NO}_3)_2$  cannot be done by this.
15. (c) **NOTE** : In an electrolytic cell, electrons do not flow themselves. It is the migration of ions towards oppositely charged electrodes that indirectly constitutes the flow of electrons from cathode to anode through internal supply.
16. (b) **TIPS/FORMULAE** :  
Use Nernst's equation;  
Cell reaction :  $\text{Zn} + \text{Fe}^{2+} \rightarrow \text{Zn}^{2+} + \text{Fe}$   
Using Nernst equation  
 $E_{\text{cell}} = E_{\text{cell}}^\circ - \frac{0.0591}{n} \log \left[ \frac{\text{Zn}^{2+}}{\text{Fe}^{2+}} \right]$   
 $E = E^\circ - \frac{0.0591}{2} \log \frac{10^{-2}}{10^{-3}}$   
 $E^\circ = 0.2905 + \frac{0.0591}{2} = 0.32$   
or  $0.32 = \frac{0.0591}{2} \log K_{\text{eq}}$  or  $K_{\text{eq}} = 10^{0.0295}$

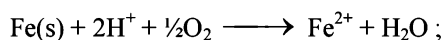
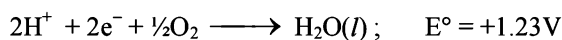
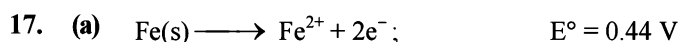

$$E_{\text{cell}}^\circ = 0.44 + 1.23 = 1.67 \text{ V}$$

$$\therefore \Delta G^\circ = -nFE_{\text{cell}}^\circ = -2 \times 96500 \times 1.67 = -322 \text{ kJ}$$

18. (b) Give:  $I = 10$  milliamperes;  $IF = 96500 \text{ C mol}^{-1}$   
 $t = ?$ ; Moles of  $\text{H}_2$  produces =  $0.01 \text{ mol}$   
 From the law of electrolysis, we have

$$\text{Equivalent of } \text{H}_2 \text{ produces} = \frac{I \times t(\text{sec})}{96500}$$

Substituting given values, we get

$$0.01 \times 2 = \frac{10 \times 10^{-3} (\text{amperes}) \times t(\text{sec})}{96500}$$

$$\text{or } t = \frac{0.01 \times 2 \times 96500}{10 \times 10^{-3}} \text{ sec} = 19.3 \times 10^4 \text{ sec.}$$

i.e. (b) is the correct answer.

19. (d)  $\text{AgNO}_3(\text{aq}) + \text{KCl}(\text{aq}) \longrightarrow \text{AgCl}(\text{s}) + \text{KNO}_3(\text{aq})$   
 Conductivity of the solution is almost compensated due to formation of  $\text{KNO}_3(\text{aq})$ . However, after at end point, conductivity increases more rapidly due to addition of excess  $\text{AgNO}_3$  solution.

20. (d) Here  $n = 4$ , and  $[\text{H}^+] = 10^{-\text{pH}} = 10^{-3}$   
 Applying Nernst equation

$$E = E^\circ - \frac{0.059}{n} \log \frac{[\text{Fe}^{2+}]^2}{[\text{H}^+]^4 p_{\text{O}_2}}$$

$$= 1.67 - \frac{0.059}{4} \log \frac{(10^{-3})^2}{(10^{-3})^4 \times 0.1}$$

$$= 1.67 - \frac{0.03}{2} \log 10^7 = 1.67 - 0.105 = 1.565 \text{ V}$$

21. (d) At anode:  $\text{H}_2(\text{g}) \rightleftharpoons 2\text{H}^+(\text{aq}) + 2\text{e}^-$

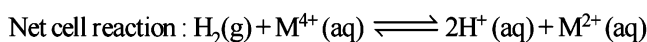
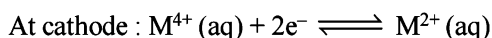

$$\text{Now, } E_{\text{cell}} = \left( E_{\text{M}^{4+}/\text{M}^{2+}}^\circ - E_{\text{H}^+/\text{H}_2}^\circ \right) -$$

$$\frac{0.059}{n} \log \frac{[\text{H}^+]^2 [\text{M}^{2+}]}{P_{\text{H}_2} [\text{M}^{4+}]}$$

$$\text{or, } 0.092 = (0.151 - 0) - \frac{0.059}{2} \log \frac{1^2 \times [\text{M}^{2+}]}{1 \times [\text{M}^{4+}]}$$

$$\therefore \frac{[\text{M}^{2+}]}{[\text{M}^{4+}]} = 10^2 \Rightarrow x = 2$$

## D. MCQs with One or More Than One Correct

- (a) **NOTE**: More negative or lower is the reduction potential, more is the reducing property. Thus the reducing power of the corresponding metal will follow the reverse order, i.e.  $Y > Z > X$ .
- (a,b,d) The species having less reduction potential with respect to  $\text{NO}_3^-$  ( $E^\circ = +0.96 \text{ V}$ ) will be oxidised by  $\text{NO}_3^-$ . These species are V, Fe and Hg.
- (a) Salt bridge is introduced to keep the solutions of two electrodes separate, so that the ions in electrodes do not mix freely with each other. Salt bridge maintains the diffusion of ions from one electrode to another.

## E. Subjective Problems

- Wt. of Cu deposited = Zit

$$\text{Electrochemical equivalent of Cu} = \frac{63.5}{2} = 31.75$$

$$\text{Volume of surface} = \text{area} \times \text{thickness} \\ = 10 \times 10 \times 10^{-2} = 1 \text{ cc}$$

$$\text{Weight of Cu} = \text{density} \times \text{volume} = 8.94 \times 1 = 8.94 \text{ g}$$

According to Faraday's laws of electrolysis

31.75 g of Cu is deposited by = 96500 coulombs of electricity

$$\therefore 8.94 \text{ g of Cu is deposited by} = \frac{96500}{31.75} \times 8.94 \\ = 27171.96 \text{ coulombs}$$

- (a) 
$$2\text{SnCl}_2 \longrightarrow \text{Sn} + \text{SnCl}_4$$
  

$$\frac{2[119 + (2 \times 35.5)]}{= 380} \quad \quad \quad \frac{119}{119} \quad \quad \frac{119 + (4 \times 35.5)}{= 261}$$

$\therefore 119 \text{ g Sn deposits from} = 380 \text{ g SnCl}_2$

$$\therefore 0.119 \text{ g Sn deposits from} = \frac{380}{119} \times 0.119$$

$$= 0.380 \text{ g SnCl}_2$$

$\therefore 380 \text{ g SnCl}_2 \text{ gives} = 261 \text{ g SnCl}_4$

$$\therefore 0.380 \text{ g SnCl}_2 \text{ gives} = \frac{261}{380} \times 0.380 = 0.261 \text{ g SnCl}_4$$

$$\therefore \text{Wt of SnCl}_2 \text{ left after decomposition} = 19.00 - 0.380 \\ = 18.620 \text{ g.}$$

Ratio  $\text{SnCl}_2 : \text{SnCl}_4$

$$\Rightarrow 18.620 : 0.261 \Rightarrow 71.34 : 1$$

- (b)  $\text{NaCl} \xrightarrow{\text{Electricity}} \text{Na}^+ + \text{Cl}^-$

At Cathode;  $\text{Na}^+ + \text{e}^- \longrightarrow \text{Na}$



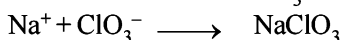
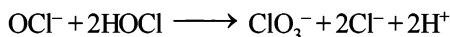
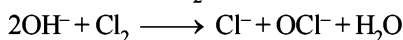
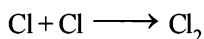
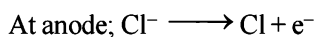
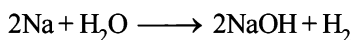

Sod. Chlorate

On prolonged electrolysis

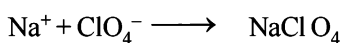
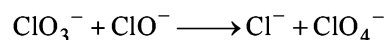

Sod. perchlorate

(c) Charge on  $\text{N}^{3-} = 3$

$$\text{No. of ions in 14 g of } \text{N}^{3-} = 6.02 \times 10^{23}$$

$$\text{No. of ions in 1 g of } \text{N}^{3-} = \frac{6.02 \times 10^{23}}{14}$$

$$\text{No. of electronic charges on 1 g } \text{N}^{3-} = \frac{6.02 \times 10^{23}}{14} \times 3$$

Charge on 1 gm of  $\text{N}^{3-}$

$$= \frac{6.023 \times 10^{23} \times 3 \times 1.6 \times 10^{-19}}{14} \text{ Coulombs}$$

( $\because$  Charge on one electron is  $1.6 \times 10^{-19}$  Coulombs)

$$= 2.06 \times 10^4 \text{ Coulombs}$$

3. (i)  $2\text{KNO}_3 + 8\text{FeSO}_4 + 4\text{H}_2\text{SO}_4 (\text{conc})$



(ii)  $3\text{H}_2\text{S} + 2\text{K}_2\text{CrO}_4 + 5\text{H}_2\text{SO}_4$

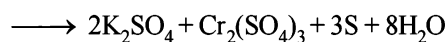

(iii)  $2\text{KI} + 2\text{H}_2\text{SO}_4 (\text{conc}) \xrightarrow{\Delta} \text{I}_2 + \text{SO}_2 + \text{K}_2\text{SO}_4 + 2\text{H}_2\text{O}$

(iv)  $\text{Mg}_3\text{N}_2 + 6\text{H}_2\text{O} \longrightarrow 3\text{Mg}(\text{OH})_2 + 2\text{NH}_3$

(v) Al is covered by layer of  $\text{Al}_2\text{O}_3$

4. (i) The two half cell reactions can be written as below :



**Thus the cell reaction will be :**  $\text{Zn} + \text{Cu}^{2+} \rightarrow \text{Zn}^{2+} + \text{Cu}$

(ii) EMF of cell,  $E^\circ_{\text{cell}} = E^\circ_{\text{cathode}} - E^\circ_{\text{anode}}$

$$E^\circ_{\text{cell}} = 0.350 - (-0.763)$$

$$= 0.350 + 0.763 \text{ volts} = 1.113 \text{ volts}$$

(iii) Since emf of the cell is **positive**, the reaction as written is **spontaneous**.

5. Gold deposited in the first cell = 9.85 g

At. wt. of Gold = 197, Oxidation number of gold = +3

$$\text{Eq. Wt. of Gold} = \frac{197}{3}$$

$W = Zit$

(where W stands for the weight of ions deposited, i for current and t for time and Z for electro-chemical equivalent of the electrolyte.)

$\therefore$  Charge required to deposit 1 g eq. of gold =  $1F = 96,500 \text{ C}$

$\therefore$  Charge required to deposit 9.85 g of gold or

$$\frac{9.85}{197/3} \text{ g eq. of gold} = \frac{96,500 \times 9.85 \times 3}{197} \text{ C}$$

$$= 965 \times 5 \times 3 \text{ C} = 14475 \text{ C}$$

According to Faraday's second law,

$$\frac{\text{Wt. of Cu}}{\text{Eq. wt. of Cu}} = \frac{\text{Wt. of Gold}}{\text{Eq. wt. of Gold}}$$

$$\Rightarrow \text{Wt. of Cu deposited} = \frac{9.85 \times 3}{197} \times \frac{63.5}{2} = 4.7625 \text{ g}$$

$$\text{Current} = \frac{Q}{t} = \frac{14475}{5 \times 3600} \text{ A} = \frac{193}{240} \text{ A} = 0.8042 \text{ A}$$

6. Volume of the surface = area  $\times$  thickness

$$= 80 \text{ cm}^2 \times \frac{0.005}{10} \text{ cm} = \frac{1}{25} \text{ cm}^3$$

Mass of Ag deposited = Volume  $\times$  Density

$$= \frac{1}{25} \times 10.5 \text{ g/cm}^3 = \frac{21}{50} \text{ g}$$

**Cell reaction :**  $\text{Ag}^+ + \text{e}^- \rightarrow \text{Ag}$

We know that,  $\frac{W}{E} = \frac{Q}{F} = \frac{it}{F}$

$E = \text{Eq. wt. of Ag} = 108$

$$\therefore \frac{21/50}{108} = \frac{i \times t}{96500}$$

$$\frac{21}{50 \times 108} = \frac{3 \times t}{96500} \quad \therefore t = 125.09 \text{ sec}$$

7. Half cell reactions will be

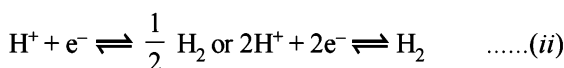
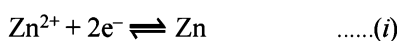

We know that  $E^\circ_{\text{Zn}/\text{Zn}^{2+}} = E^\circ_{\text{Zn}/\text{Zn}^{2+}} - \frac{RT}{nF} \ln \frac{[\text{Zn}^{2+}]}{[\text{Zn}]}$

Here  $R = 8.314 \text{ Jmol}^{-1} \text{ deg}^{-1}$ ,  $T = 298 \text{ K}$ ,  $F = 96,500 \text{ coul/equi}$ ,

$n = 2$ ,  $E^\circ_{\text{Zn}/\text{Zn}^{2+}} = 0.76 \text{ V}$ .

Substituting the values in the above equation

$$E^\circ_{\text{Zn}/\text{Zn}^{2+}} = 0.76 - \frac{8.314 \times 298}{2 \times 96500} \ln \frac{0.1}{1} = 0.79 \text{ V}$$

$$\begin{aligned} \text{Similarly, } E_{\text{H}^+/\text{H}_2} &= E_{\text{H}^+/\text{H}_2}^\circ - \frac{RT}{nF} \ln \frac{[\text{H}_2]}{[\text{H}^+]^2} \\ &= 0 - \frac{8.314 \times 298}{2 \times 96500} \ln \frac{[1]}{[\text{H}^+]^2} \\ &= 0.05915 \log_{10} [\text{H}^+] = -0.05915 \text{pH} \\ &\quad (\because -\log_{10} [\text{H}^+] = \text{pH}) \end{aligned}$$

$$\text{Now since } E = E_{\text{Zn}/\text{Zn}^{2+}} + E_{\text{H}^+/\text{H}_2}$$

$$0.28 = 0.79 - 0.05915 \text{pH} \Rightarrow \text{pH} = \frac{0.51}{0.05915} = \mathbf{8.62}$$

8. In lead storage battery the anodic and cathodic reactions during discharge (or operation or working) are as :

(i) **Anodic reaction :**

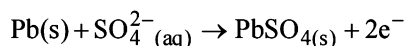

(ii) **Cathodic reaction :**

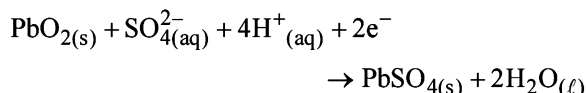

In both the half cell reactions  $\text{H}_2\text{SO}_4$  is consumed and hence conc. of  $\text{H}_2\text{SO}_4$  decreases during the working (discharging of the battery). For the withdrawal of  $2F = 2 \times 96500$  C of electric charge, 2 mol of  $\text{H}_2\text{SO}_4$  are consumed. Density of  $\text{H}_2\text{SO}_4$  solution (used as electrolyte) falls during working of the cell.

Both reactions get reversed on charging the battery leading to regeneration of  $\text{H}_2\text{SO}_4$  as :

Formerly anode but now cathode (recharging)

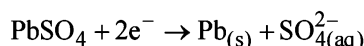

Formerly cathode but now anode :

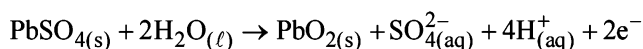

[NOTE : In 1986 IIT-JEE paper there was a mistake in the question paper itself. Reaction (ii) was shown to take place during recharging of the battery which is infact the reaction occurring at cathodic half cell during operation (discharging) of the battery.]

9. **TIPS/FORMULAE :**

$$\text{Watt} = \text{Volt} \times \text{Current} \Rightarrow 100 = 110 \times \text{Current}$$

$$\text{or Current} = \frac{100}{110} = \frac{10}{11} \text{ amp.}$$

Now we know that,

$$Q = i \times t = \frac{10}{11} \times 10 \times 3600 \times \frac{1}{96500} = 0.339 F$$

$$\text{Wt. of cadmium deposited} = \frac{0.339 \times 112.4}{2} = \mathbf{19.06 \text{ g}}$$

10. **TIPS/FORMULAE :**

For a concentration cell

$$E_{\text{cell}} = \frac{0.059}{n} \log \frac{C_1}{C_2}$$

**NOTE :** It is a concentration cell as both the electrodes are made of same element. Negative electrode acts as anode in a galvanic cell.

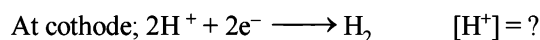
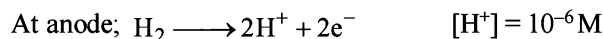

$$E_{\text{cell}} = \frac{0.059}{1} \log \left[ \frac{C_{\text{H}^+}}{10^{-6}} \right] \text{ or } 0.118 = \frac{0.059}{1} \log \left( \frac{C_{\text{H}^+}}{10^{-6}} \right)$$

$$\log \frac{C_{\text{H}^+}}{10^{-6}} = \frac{0.118}{0.059} = 2 \Rightarrow C_{\text{H}^+} = \mathbf{10^{-4} \text{ M}}$$

11. For the given reactions, it is obvious that 22.4 litres of  $\text{H}_2$  gas require 2 Faraday electricity.

$\therefore$  67.2 litres of  $\text{H}_2$  will produce = 6 Faraday electricity

$$Q = C \times t; 6 \times 96500 = C \times 15 \times 60$$

$$C = \frac{6 \times 96500}{15 \times 60} = \mathbf{643.3 \text{ ampere}}$$

*Calculation of amount of Cu deposited by 6 F*

$$\text{Since 1 F deposits} = \frac{63.5}{2} = 31.75 \text{ g of Cu}$$

$$6 \text{ F will deposit} = 31.75 \times 6 \text{ g} = \mathbf{190.50 \text{ g}}$$

12. The chemical reactions taking place at the two electrodes are

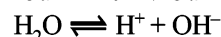

**NOTE :** Only  $\text{Cu}^{2+}$  ions will be discharged so as these are present in solution and  $\text{H}^+$  ions will be discharged only when all the  $\text{Cu}^{2+}$  ions have been deposited.

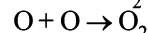
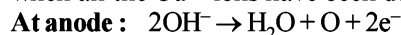

Thus in first case,  $\text{Cu}^{2+}$  ion will be discharged at the cathode and  $\text{O}_2$  gas at the anode. Let us calculate the volume of gas ( $\text{O}_2$ ) discharged during electrolysis.

According to Faraday's second law

$$31.75 \text{ g Cu} \equiv 8 \text{ g of oxygen} \equiv 5.6 \text{ litres of } \text{O}_2 \text{ at NTP}$$

$$0.4 \text{ g Cu} = \frac{5.6}{31.75} \times 0.4 \text{ litres of } \text{O}_2 \text{ at NTP}$$

$$= 0.07055 \text{ litres} = 70.55 \text{ ml}$$

As explained earlier, when all the  $\text{Cu}^{2+}$  ion will be deposited at cathode,  $\text{H}^+$  ions will start going to cathode liberating hydrogen ( $\text{H}_2$ ) gas, *i.e.*

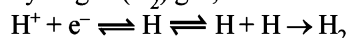

**NOTE THIS STEP :** However, the anode reaction remains same as previous. Thus in the second (latter) case, amount of  $\text{H}_2$  collected at cathode should be calculated.

$$8 \text{ g of } \text{O}_2 \equiv 1 \text{ g of } \text{H}_2$$

$$5.6 \text{ litres of } \text{O}_2 \text{ at NTP} = 11.2 \text{ litres of hydrogen}$$

Quantity of electricity passed after 1st electrolysis,

$$\text{i.e. } Q = i \times t = 1.2 \times 7 \times 60 = 504 \text{ coulombs}$$

$$504 \text{ coulombs will liberate} = \frac{5.6 \times 504}{96500} = 29.24 \text{ ml of } \text{O}_2.$$

Similarly,  $H_2$  liberated by 504 coulombs

$$= 11.2 \times \frac{504}{96500} = 58.48 \text{ ml}$$

(Twice the volume of  $O_2$  liberated in latter phase  
 $= 2 \times 29.24 = 58.48 \text{ ml}$ )

Total volume of  $O_2$  liberated =  $70.55 + 29.24 = 99.79 \text{ ml}$

Vol. of  $H_2$  liberated = **58.48 ml**

### 13. TIPS/FORMULAE:

$$E_{\text{cell}}^{\circ} = \frac{0.0591}{n} \log K_c \quad \text{or} \quad \frac{RT}{nF} \log K_c$$

Let us split the desired reaction into two half cell reactions:

**Oxidation half reaction:**

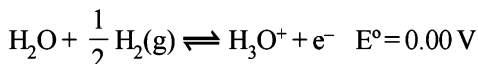

**Reduction half reaction:**

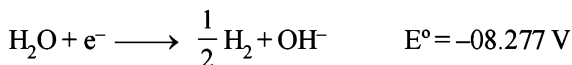

**Net reaction:**



So, the number of electrons involved in redox reaction,  
 $(n) = 1$

$$\text{We know that } E_{\text{cell}}^{\circ} = \frac{0.0591}{n} \log K_c$$

$$\log K_c = \frac{E_{\text{cell}}^{\circ} \times n}{0.0591} = \frac{(-0.8277) \times 1}{0.0591} = -14.005$$

$$K_c = \text{Antilog}[15.995] = 9.88 \times 10^{-15}$$

### 14. $E_{\text{Cu}^{2+}/\text{Cu}}^{\circ} = 0.337$ and $E_{\text{Ag}^+/\text{Ag}}^{\circ} = 0.799 \text{ V}$

$$E_{\text{Ag}^+/\text{Ag}}^{\circ} + E_{\text{Cu}/\text{Cu}^{2+}}^{\circ} = 0.799 - 0.337 = 0.462 \text{ V}$$

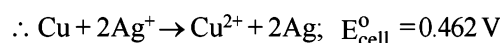

Hence the galvanic cell in question will consist of **anode of copper and cathode of silver.**

*Calculation of concentration:*

$$E_{\text{cell}} = E^{\circ} - \frac{0.059}{n} \log \frac{[\text{Products}]}{[\text{Reactants}]}$$

$$E_{\text{cell}}^{\circ} = \frac{0.059}{n} \log \frac{[\text{Products}]}{[\text{Reactants}]} \quad [\because E_{\text{cell}} = 0]$$

$$0.462 = \frac{0.059}{2} \log \frac{0.01}{[\text{Ag}^+]^2} \quad [n = 2]$$

$$\frac{462 \times 2}{59} = \log(10^{-2}) - \log[\text{Ag}^+]^2$$

$$\frac{924}{59} = -2 - 2\log[\text{Ag}^+] \Rightarrow [\text{Ag}^+] = 1.48 \times 10^{-9} \text{ M}$$

### 15. $C_6H_5NO_2 + 6H^+ + 6e^- \longrightarrow C_6H_5NH_2 + 2H_2O$

$$\text{Eq. wt of } C_6H_5NO_2 = \frac{\text{M.wt.}}{6} = \frac{123}{6}$$

$$w = \frac{E_{\text{it}}}{96500}$$

$$\therefore \text{current efficiency} = 50\%$$

$$\therefore i = \frac{50i_0}{100}$$

$$\therefore 12.3 = \frac{123 \times i \times t \times 50}{6 \times 100 \times 96500}$$

$$i \times t = Q = 115800 \text{ Coulomb}$$

$$\text{Energy used} = 115800 \times 3 = 347.4 \text{ kJ.}$$

### 16. The following chemical cell sets up:

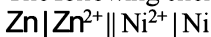

The net cell reaction is:  $\text{Zn} + \text{Ni}^{2+} \rightleftharpoons \text{Zn}^{2+} + \text{Ni}$

The e.m.f. is given by

$$E_{\text{cell}} = E_{\text{Ni}^{2+}/\text{Ni}}^{\circ} - E_{\text{Zn}^{2+}/\text{Zn}}^{\circ} - \frac{0.059}{2} \log \frac{[\text{Zn}^{2+}]}{[\text{Ni}^{2+}]}$$

$$= -0.24 - (-0.75) - 0.0295 \log \frac{[\text{Zn}^{2+}]}{[\text{Ni}^{2+}]}$$

$$= 0.51 - 0.0295 \log \frac{[\text{Zn}^{2+}]}{[\text{Ni}^{2+}]}$$

At equilibrium  $E_{\text{cell}} = 0$

Let  $x \text{ mol } l^{-1}$  be the concentration of  $\text{Ni}^{2+}$  at equilibrium.

Then  $[\text{Zn}^{2+}] = 1 - x$  [ $\because$  1 mole of  $\text{Ni}^{2+}$  gives 1 mole of  $\text{Zn}^{2+}$ ]

$$\therefore 0.0295 \log \frac{1-x}{x} = 0.51$$

$$\text{or } \log \frac{1-x}{x} = \frac{0.51}{0.0295} = 17.29 \quad \text{or } \frac{1-x}{x} = 1.95 \times 10^{17}$$

$$\text{or } x = \frac{1}{1.95 \times 10^{17}} = 5.128 \times 10^{-18} \text{ mol } l^{-1}$$

### 17. $i = \frac{1.70 \times 90}{100}$ ampere

No. of equivalents of  $\text{Zn}^{2+}$  which are lost

$$= \frac{i \times t}{96500} = \frac{1.70 \times 90 \times 230}{100 \times 96500} = 3.646 \times 10^{-3}$$

$\therefore$  Milli equivalents of  $\text{Zn}^{2+}$  which are lost 3.646

$\therefore$  Initial value of  $\text{Zn}^{2+} = 300 \times 0.160 \times 2 = 96$

$\therefore$  Milli equivalents of  $\text{Zn}^{2+}$  left in solution

$$= 96 - 3.646 = 92.354$$

$$[\text{ZnSO}_4] = \frac{92.354}{2 \times 300} = 0.154 \text{ M}$$

$\therefore$  Molarity of  $\text{Zn}^{2+} = 0.154 \text{ M}$

### 18. $\text{Ag} | \text{AgCl}(s), \text{KCl}(0.2\text{M}) || \text{KBr}(0.001\text{M}), \text{AgBr}(s) | \text{Ag}$

$$K_{\text{sp}}(\text{AgCl}) = 2.8 \times 10^{-10} \quad K_{\text{sp}}(\text{AgBr}) = 3.3 \times 10^{-13}$$

At anode,  ${}_1\text{Ag} \rightarrow {}_1\text{Ag}^+ + e^-$

At cathode,  ${}_2\text{Ag}^+ + e^- \rightarrow {}_2\text{Ag}$

$\therefore$  Cell reaction  ${}_1\text{Ag} + {}_2\text{Ag}^+ \rightarrow {}_2\text{Ag} + {}_1\text{Ag}^+$

**NOTE:** The subscripts 1 and 2 on Ag denote the species concerned with anode and cathode respectively.

Applying Nernst equation

$$E = E^{\circ} - \frac{0.059}{n} \log \left[ \frac{\text{Products}}{\text{Reactants}} \right]$$

$$= 0 - \frac{0.059}{1} \log \left[ \frac{{}_2\text{Ag} \times {}_1\text{Ag}^+}{{}_1\text{Ag} \times {}_2\text{Ag}^+} \right]$$

$$[{}_1\text{Ag}] = [{}_2\text{Ag}] = 1 \quad (\because \text{these are in solid state})$$

$$K_{\text{sp}}(\text{AgCl}) = 2.8 \times 10^{-10} \text{ or } [{}_1\text{Ag}^+][\text{Cl}^-] = 2.8 \times 10^{-10}$$

$$[{}_1\text{Ag}^+] = \frac{2.8 \times 10^{-10}}{0.2} = 14 \times 10^{-10} \quad (\because [\text{Cl}^-] = 0.2)$$

$$K_{\text{sp}}(\text{AgBr}) = 3.3 \times 10^{-13} \text{ or } [{}_2\text{Ag}^+][\text{Br}^-] = 3.3 \times 10^{-13}$$

$$[{}_2\text{Ag}^+] = \frac{3.3 \times 10^{-13}}{0.001} = 3.3 \times 10^{-10} \quad (\because [\text{Br}^-] = 0.001)$$

$$\therefore E = -\frac{0.059}{1} \log \left[ \frac{14 \times 10^{-10}}{3.3 \times 10^{-10}} \right]$$

$$= -0.059 \log \left[ \frac{14}{3.3} \right] = -0.059 \times 0.6276 = -0.037 \text{ V}$$

Since emf is negative this shows that the reaction is non-spontaneous.

**NOTE :** For the reaction to be spontaneous, its emf should be positive i.e.  $E = 0.037 \text{ V}$  and its polarities should be reversed i.e. anode should be made cathode and *vice-versa*. So the galvanic cell is :  $\text{Ag} | \text{AgBr}(s), \text{KBr} || \text{AgCl}(s), \text{KCl} | \text{Ag}$   
In other words,  $\text{Ag} | \text{AgBr}$  acts as anode and  $\text{AgCl} | \text{Ag}$  acts as cathode.

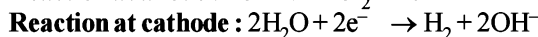
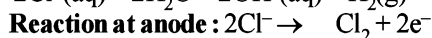
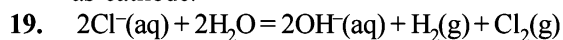

$$i = \frac{62}{100} \times 25 = 15.4 \text{ amperes}$$

Weight of  $\text{Cl}_2$  deposited = 1 kg or 1000 gm

$$\text{We know that } \frac{W}{E} = \frac{Q}{F} = \frac{it}{F}; \frac{1000}{35.5} = \frac{15.4 \times t}{96500}$$

$$t = 175300 \text{ sec. or } 48.69 \text{ hours}$$

$$\text{No. of moles of } \text{Cl}_2 \text{ thus produced} = \frac{1000}{71} = 14.08$$

$$\text{Amount of } \text{OH}^- \text{ released in the electrolysis} \\ = 2 \times 14.08 \text{ moles} = 28.16 \text{ moles}$$

$$\therefore \text{Molarity with respect to } \text{OH}^- = \frac{28.16 \text{ moles}}{20 \text{ l}} = 1.408 \text{ M}$$

20. For the half-cell reaction

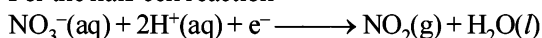

$$\text{The Nernst equation is } E = E^\circ - \frac{0.059}{n} \log \frac{[\text{Products}]}{[\text{Reactants}]}$$

Substituting the values in case of (a)

$$E = 0.78 - \frac{0.059}{1} \log \frac{1}{(8)^2} = 0.78 + 0.059 \log 64 = 0.887 \text{ V}$$

Substituting the value in the Nernst equation in case (b)

$$E = 0.78 - \frac{0.059}{1} \log \frac{1}{(10^{-7})^2} = 0.78 - 0.059 \log 10^{-14} \\ = 0.78 - (0.059) \times (14) = -0.046 \text{ V}$$

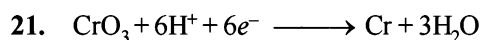

Eq. wt. of Cr

At. wt.

$$= \frac{\text{At. wt.}}{\text{No. of Electrons lost or gained by one molecule of Cr}}$$

$$= \frac{52}{6}$$

(i)  $\therefore 96500 \text{ coulomb deposit} = \left( \frac{52}{6} \right) \text{ g Cr}$

$$\therefore 24000 \text{ coulomb deposit} = \frac{52}{6} \times \frac{24000}{96500} \\ = 2.1554 \text{ g of Cr}$$

(ii) Also given,  $w_{\text{Cr}} = 1.5 \text{ g}$ ,  $i = 12.5 \text{ ampere}$ ,  $t = ?$ ,  $E_{\text{Cr}} = \frac{52}{6}$

$$\therefore w = \frac{E \cdot i \cdot t}{96500} \text{ or } 1.5 = \frac{52 \times 12.5 \times t}{6 \times 96500}$$

$$\therefore t = 1336.15 \text{ second}$$

22.  $E^\circ =$  Standard reduction potential of the  $\text{Ag}^+/\text{Ag}$  electrode = 0.799 V

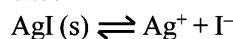

$$K_{\text{sp}} = [\text{Ag}^+][\text{I}^-] = 8.7 \times 10^{-17} \text{ (given)}$$

If 'S' is the solubility of AgI, then  $K_{\text{sp}} = S^2$

$$\therefore S = \sqrt{K_{\text{sp}}} = \sqrt{8.7 \times 10^{-17}} = 9.327 \times 10^{-9} \text{ mol L}^{-1}$$

$$\therefore [\text{Ag}^+] = [\text{I}^-] = 9.327 \times 10^{-9} \text{ M}$$

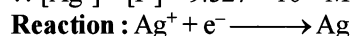

$$\therefore E = E^\circ - \frac{0.059}{n} \log \frac{a_{\text{Ag}}}{a_{\text{Ag}^+}}$$

$$= 0.799 \text{ V} - \frac{0.059}{1} \log \frac{1}{9.327 \times 10^{-9}}$$

[ $\because$  Activity of the electrode material in pure solid state is taken as one]

$$= 0.799 - 0.059 \log 0.1072 \times 10^9$$

$$= 0.799 - 0.474 = 0.325 \text{ V}$$

Again,

L.H.S. Electrode reaction :

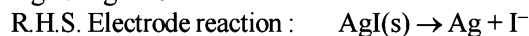

$$K = \text{Equilibrium constant} = [\text{Ag}^+][\text{I}^-] = 8.7 \times 10^{-17}$$

The standard cell emf  $E^\circ$  and the equilibrium constant  $k$  are related by the expression.

$$E_{\text{cell}}^\circ = \frac{0.059}{n} \log K \text{ at } 298 \text{ K, Here, } n = 1, K = 8.7 \times 10^{-17}$$

$$E_{\text{cell}}^\circ = 0.059 \log 8.7 \times 10^{-17} = 0.059 [0.9395 - 17] = -0.948 \text{ V}$$

$$\text{But } E_{\text{cell}}^\circ = E_{\text{R.H.S.}}^\circ - E_{\text{L.H.S.}}^\circ$$

$$\therefore E_{\text{R.H.S.}}^\circ = E_{\text{cell}}^\circ + E_{\text{L.H.S.}}^\circ = -0.948 + 0.799 = -0.149 \text{ V}$$

23. (i) Given  $E_{\text{Ni}_2\text{O}_3/\text{NiO}}^\circ = +0.40 \text{ V}$ ;  $E_{\text{FeO}/\text{Fe}}^\circ = -0.87 \text{ V}$

$$E_{\text{NiO}/\text{Ni}_2\text{O}_3}^\circ = -0.40 \text{ V}; E_{\text{Fe}/\text{FeO}}^\circ = +0.87 \text{ V}$$

Since  $E_{\text{ox. pot.}}^\circ$  for Fe/FeO >  $E_{\text{ox. pot.}}^\circ$  for NiO/Ni<sub>2</sub>O<sub>3</sub>.

Redox changes can be written as

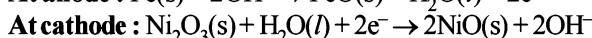
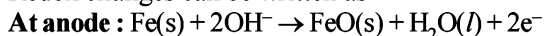

(ii)  $E_{\text{cell}} = E_{\text{OP Fe/FeO}}^\circ + E_{\text{RP Ni}_2\text{O}_3/\text{NiO}}^\circ$   
 $= 0.87 + 0.40 = 1.27 \text{ V}$

It is independent of conc. of KOH

(iii) Electrical energy =  $nFE_{\text{cell}} = 2 \times 96500 \text{ J V}^{-1} \times 1.27 \text{ V}$   
 $= 2.45 \times 10^5 \text{ J}$

24. The thin protective layer of oxides of aluminium is formed which protects the metal from further attack of water and air and make it stable.

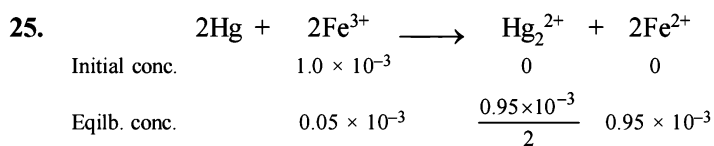

$$E = E_{\text{Fe}^{3+}/\text{Fe}^{2+}}^\circ - E_{\text{Hg}_2^{2+}/\text{Hg}}^\circ - \frac{0.059}{n} \log \frac{[\text{Fe}^{2+}]^2 [\text{Hg}_2^{2+}]}{[\text{Fe}^{3+}]^2}$$

**NOTE:** At equilibrium,  $E = 0$

$$\Rightarrow 0 = 0.77 - E_{\text{Hg}_2^{2+}/\text{Hg}}^\circ - \frac{0.059}{2} \log \frac{(0.95 \times 10^{-3})^2 (0.475 \times 10^{-3})}{(0.05 \times 10^{-3})^2}$$

On usual calculations,  $E_{\text{Hg}_2^{2+}/\text{Hg}}^\circ = 0.792 \text{ V}$

26. At pH = 14;  $[\text{H}^+] = 1 \times 10^{-14} \text{ M}$ ;  $[\text{OH}^-] = 10^0 = 1 \text{ M}$   
 ( $\therefore [\text{H}^+][\text{OH}^-] = 1 \times 10^{-14}$ )

$\therefore \text{Cu(OH)}_2$  ionises as follows:

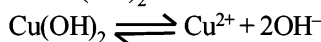

$$\therefore K_{\text{sp}} \text{ of } \text{Cu(OH)}_2 = [\text{Cu}^{2+}][\text{OH}^-]^2$$

$$1.0 \times 10^{-19} = [\text{Cu}^{2+}][1]^2; [\text{Cu}^{2+}] = 1.0 \times 10^{-19} \text{ M}$$

The standard reduction potential of  $\text{Cu}^{2+}/\text{Cu}$  is represented in the form of following equation:

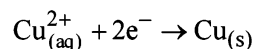

On applying Nernst equation

$$E = E^\circ - \frac{0.0591}{n} \log \frac{1}{[\text{Cu}^{2+}]}$$

$$= +0.34 - \frac{0.0591}{2} \log \frac{1}{1 \times 10^{-19}}$$

$$= +0.34 - \frac{0.0591}{2} [-\log_{10} 10^{-19}]$$

$$= \left[ 0.34 - \frac{0.0591}{2} \times 19 \right] = 0.34 - 0.56 = -0.22 \text{ V}$$

27.  $W_{\text{Ag}} = \frac{\text{E.i.t}}{96500} = \frac{107.8 \times 8.46 \times 8 \times 60 \times 60}{96500} = 34.02 \text{ g}$

$$\text{Volume of Ag} = \frac{34.02}{10.5} = 3.24 \text{ ml}$$

$$\therefore \text{Surface area} = \frac{3.24}{0.00254} = 1275.6 \text{ cm}^2$$

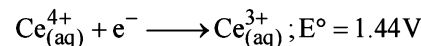
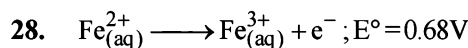

$$E_{\text{cell}}^\circ = 1.44 - 0.68 = +0.76 \text{ V}$$

at equilibriums,  $E_{\text{cell}} = 0$

$$E_{\text{cell}}^\circ = \frac{0.0591}{n} \log_{10} K_c; 0.76 = \frac{0.0591}{1} \log_{10} K_c$$

$$\text{or } \log_{10} K_c = \frac{0.76}{0.0591} = 12.859 \therefore K_c = 7.6 \times 10^{12}$$

29. For the change  $2\text{Fe}^{3+} + 3\text{I}^- \rightleftharpoons 2\text{Fe}^{2+} + \text{I}_3^-$ ,

$$E = E^\circ - \frac{0.059}{2} \log K_c \text{ or } E^\circ = \frac{0.059}{2} \log K_c$$

( $\therefore$  at equilibrium,  $E = 0$ )

$$\text{Also } E_{\text{cell}}^\circ = E_{\text{RP Fe}^{3+}/\text{Fe}^{2+}}^\circ + E_{\text{OP I}^-/\text{I}_3^-}^\circ$$

$$= 0.77 - 0.54 = 0.23 \text{ V}$$

$$E_{\text{cell}} = E_{\text{cell}}^\circ - \frac{0.059}{2} \log K_c$$

At equilibrium,  $E_{\text{cell}} = 0$  (Using Nernst equation)

$$\text{Thus, } 0.23 = \frac{0.059}{2} \log K_c \therefore K_c = 6.26 \times 10^7$$

30. The cell reaction can be written as

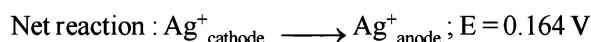
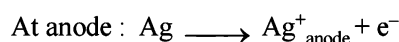

Thus here,  $n = 1$ ,  $E = 0.164 \text{ V}$ ,  $[\text{Ag}^+]_{\text{cathode}} = 0.1 \text{ M}$

Let the solubility of  $\text{Ag}_2\text{CrO}_4$  be  $S \text{ M}$

Since  $\text{Ag}_2\text{CrO}_4$  gives  $2 \text{ Ag}^+$

$\therefore$  Here concentration of  $[\text{Ag}^+]_{\text{anode}} = 2 \text{ S M}$

$$\therefore 0.164 = -\frac{0.059}{1} \log \frac{[\text{Ag}^+]_{\text{anode}}}{[\text{Ag}^+]_{\text{cathode}}}$$

$$0.164 = -\frac{0.059}{1} \log \frac{2S}{0.1}$$

$$\text{or } 0.164 = \frac{0.059}{1} \log \frac{0.1}{2S} \therefore 2S = 1.697 \times 10^{-4}$$

Hence  $S = 0.8485 \times 10^{-4} \text{ M}$

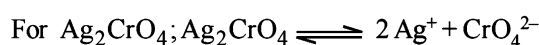

$$K_{\text{sp}} = (2S)^2 (S) = 4S^3$$

$$\therefore K_{\text{sp}} = 4 \times (0.8485 \times 10^{-4})^3 = 2.44 \times 10^{-12}$$

31. Note that the given cell will not work as electrochemical cell

since  $E^{\circ}_{\text{OP}_{\text{Cu}}} > E^{\circ}_{\text{OP}_{\text{Ag}^+}}$

The equation for electro-chemical cells will be:

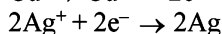

Thus, e.m.f. of cell  $\text{Cu} | \text{Cu}^{2+} || \text{Ag}^+ | \text{Ag}$  will be

$$E_{\text{cell}} = E^{\circ}_{\text{OP}_{\text{Cu}}} + E^{\circ}_{\text{RPAg}} + \frac{0.059}{2} \log \frac{[\text{Ag}^+]^2}{[\text{Cu}^{2+}]}$$

$$\therefore [\text{Ag}^+] = 1\text{M and } [\text{Cu}^{2+}] = 1\text{M}$$

$$\therefore E_{\text{cell}} = E^{\circ}_{\text{OP}_{\text{Cu}}} + E^{\circ}_{\text{RPAg}}$$

$$(E^{\circ}_{\text{cell}} = E^{\circ}_{\text{OP}_{\text{Cu}}} + E^{\circ}_{\text{RPAg}}) \Rightarrow E_{\text{cell}} = E^{\circ}_{\text{cell}}$$

After the passage of 9.65 ampere for 1 hr i.e.  $9.65 \times 60 \times 60$  Coulomb charge, during which the cell reactions are reversed, the Ag metal passes in solution state and  $\text{Cu}^{2+}$  ions are discharged. The reactions during the passage of current are:



$$\text{Thus, Ag}^+ \text{ formed} = \frac{9.65 \times 60 \times 60}{96500} = 0.36 \text{ eq.} = 0.36 \text{ mole}$$

$$\text{Cu}^{2+} \text{ discharged} = \frac{9.65 \times 60 \times 60}{96500} = 0.36 \text{ eq.} = 0.18 \text{ mole}$$

$$\text{Thus } [\text{Ag}^+] \text{ left} = 1 + 0.36 = 1.36 \text{ mole}$$

$$[\text{Cu}^{2+}] \text{ left} = 1 - 0.18 = 0.82 \text{ mole.}$$

Now e.m.f. can be given as:

$$E_{\text{cell}} = E^{\circ}_{\text{cell}} + \frac{0.059}{2} \log \frac{(1.36)^2}{0.82} = E^{\circ}_{\text{cell}} + 0.010 \text{ V}$$

Thus  $E_{\text{cell}}$  increases by **0.010 V**.

32.  $m = Zit$

$$Z \text{ for Cu} = \frac{63.5/2}{96500}; t = 16 \times 60 \text{ sec}$$

$$\therefore m = \frac{63.5}{2 \times 96500} \times 2 \times 10^{-3} \times 16 \times 60$$

$$= \frac{63.5 \times 16 \times 60 \times 10^{-3}}{96500} \text{ g}$$

Wt. of Cu at 50% electrolysis of  $\text{CuSO}_4$

$$= \frac{63.5 \times 16 \times 60 \times 10^{-3}}{96500} \text{ g}$$

Wt. of Cu at 100% electrolysis of  $\text{CuSO}_4$

$$= \frac{63.5 \times 2 \times 16 \times 60 \times 10^{-3}}{96500} \text{ g} = 0.198 \times 63.5 \times 10^{-4} \text{ g}$$

$$\text{CuSO}_4 \equiv \text{Cu} \quad = 0.198 \times 10^{-4} \text{ mol.}$$

$$\therefore \text{Conc. of } \text{CuSO}_4 = 0.198 \times 10^{-4} \times \frac{1000}{250} \\ = 7.95 \times 10^{-5} \text{ mol/L}$$

33. Given,  $E^{\circ}_{\text{Ce}^{4+}/\text{Ce}^{3+}} = 1.61\text{V}$ ;  $E^{\circ}_{\text{Fe}^{3+}/\text{Fe}^{2+}} = 0.77\text{V}$

Thus for  $E^{\circ}_{\text{cell}}$  to be positive, following reaction should occur



Hence  $\text{Ce}^{4+} / \text{Ce}^{3+}$  electrode will act as cathode and  $\text{Fe}^{3+} / \text{Fe}^{2+}$  electrode will act as anode.

Therefore **current will flow from Ce electrode to iron electrode.**

Current will **decrease** with time.

34. (i) The half cell reactions are

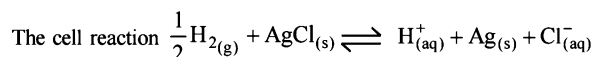
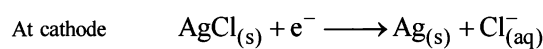
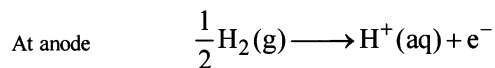

(ii) **TIPS/FORMULAE:**

$$\text{We know that } \Delta S = nF \frac{dE}{dT}$$

$n \rightarrow$  No. of transferred electrons = 1

$F \rightarrow$  faraday number = 96500 coulombs

$dE \rightarrow$  Difference of electrode potential at two different temperatures =  $(0.21 - 0.23) = -0.02\text{V}$

$dT \rightarrow$  Difference of two temperatures =  $(35^\circ\text{C} - 15^\circ\text{C}) = 20^\circ\text{C}$

$$\therefore \Delta S^\circ = 1 \times 96500 \times \frac{-0.02}{20} = -96.5 \text{ J/K mole ;}$$

$$\therefore E_{15}^\circ = 0.23 \text{ V ; } \Delta G^\circ = -nE^\circ F$$

$$\text{so } \Delta G^\circ_{15} = -1 \times 0.23 \times 96500 \text{ J} = -22195 \text{ J/mole}$$

$$\Delta H^\circ = \Delta G^\circ - T\Delta S^\circ = -22195 - 288 \times (-96.5) \\ = -49987 \text{ J/mole.}$$

(iii)  $E^{\circ}_{25^\circ\text{C}}$  of cell

$$= E_{15}^\circ - \frac{dE}{dT} \times \Delta T = \left( 0.23 - \frac{0.02}{20} \times 10 \right) \text{ V} = 0.22 \text{ V}$$

The corresponding cell is represented as :

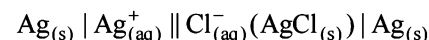

In form of oxidised electrode potential

$$E^{\circ}_{\text{cell}} = E^{\circ}_{\text{anode}} - E^{\circ}_{\text{Cathode}} = E^{\circ}_{\text{Ag}/\text{Ag}^+} - E^{\circ}_{\text{Ag}/\text{AgCl}/\text{Cl}^-} \\ = -0.80 - (0.22) = 0.58 \text{ V}$$

$$E^{\circ}_{\text{cell}} = \frac{0.0591}{n} \log_{10} K_{\text{eq}}$$

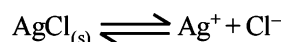

$$E^{\circ}_{\text{cell}} = \frac{0.0591}{n} \log_{10} [\text{Ag}^+][\text{Cl}^-] = \frac{0.0591}{n} \log_{10} K_{\text{sp}}$$

$$\text{Therefore } -0.58 = \frac{0.0591}{1} \log_{10} K_{\text{sp}}$$

$$\text{or } \log_{10} K_{\text{sp}} = -9.8139 = \overline{10}.1861; K_{\text{sp}} = 1.54 \times 10^{-10}$$

$$K_{\text{sp}} \text{ of } \text{AgCl} = 1.54 \times 10^{-10} \text{ (mole Litre}^{-1}\text{)}^2$$

Solubility of AgCl

$$= \sqrt{K_{\text{sp}}} = \sqrt{1.54 \times 10^{-10}} = 1.24 \times 10^{-5} \text{ mole/L}$$

35. Daniel cell is :  $\text{Zn} | \text{Zn}^{2+} || \text{Cu}^{2+} | \text{Cu}$   
Let there be two Daniel cells with their  $E_{\text{cell}}$  as given below:

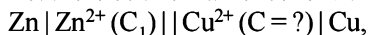

$$E_{\text{cell}} = E_1$$

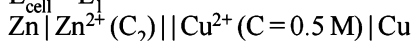

$$E_{\text{cell}} = E_2 \text{ where } E_2 > E_1$$

According to question,  $E_2 - E_1 = 0.03$  and  $C_2 = C_1$

The cell reaction is

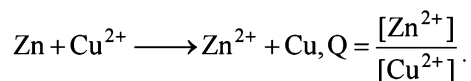

$$\text{So, } E_{\text{cell}} = E_{\text{cell}}^{\circ} - \frac{0.06}{2} \log \frac{[\text{Zn}^{2+}]}{[\text{Cu}^{2+}]}$$

$$\text{Thus, } E_1 = E_{\text{cell}}^{\circ} - \frac{0.06}{2} \log \frac{C_1}{C}$$

$$\text{and } E_2 = E_{\text{cell}}^{\circ} - \frac{0.06}{2} \log \frac{C_2}{0.5}$$

Since same  $\text{ZnSO}_4$  is used in both cells  $C_1 = C_2$

$$\text{So, } E_2 - E_1 = \frac{0.06}{2} \left[ \log \frac{C_1}{C} \times \frac{0.5}{C_1} \right]$$

$$\Rightarrow 0.03 = \frac{0.06}{2} \log \frac{0.5}{C} \Rightarrow \log \frac{0.5}{C} = 1 \text{ or } C = \mathbf{0.05 \text{ M}}$$

36. The required reaction can be obtained in the following way.

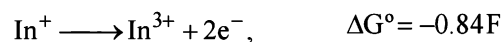
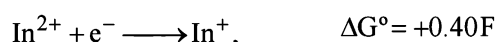
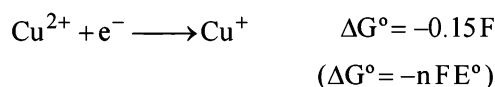

On adding,  $\text{Cu}^{2+} + \text{In}^{2+} \longrightarrow \text{In}^{3+} + \text{Cu}^{+}$ ,  $E^{\circ} = -0.59 \text{ F}$

Now we know that  $-nFE^{\circ} = -0.59 \text{ F}$

$$\text{or } -E_{\text{cell}}^{\circ} = -0.59 \text{ V or } E_{\text{cell}}^{\circ} = 0.59 \text{ V}$$

$$E_{\text{cell}} = E_{\text{cell}}^{\circ} - \frac{0.0591}{n} \log K_c ;$$

$$E_{\text{cell}}^{\circ} = 0, \text{ then } E_{\text{cell}}^{\circ} = \frac{0.0591}{n} \log K_c$$

$$0.59 = \frac{0.0591}{1} \log K_c$$

$$\log K_c = \frac{0.59}{0.0591} = 10 ; \quad K_c = \mathbf{10^{10}}$$

37. (a) From the given details, the reactions can be written as:

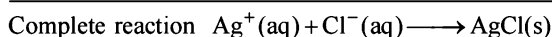
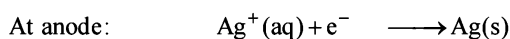
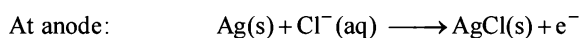

Hence cell representation is

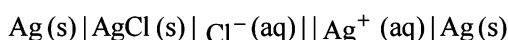

$$\Delta G^{\circ} = \Delta G_f^{\circ}(\text{AgCl}) - [\Delta G_f^{\circ}(\text{Ag}^{+}) + \Delta G_f^{\circ}(\text{Cl}^{-})]$$

$$= -109 - (-129 + 77) = -57 \text{ kJ/mol} = -57000 \text{ J/mol}$$

We know that,  $\Delta G^{\circ} = -nFE_{\text{cell}}^{\circ}$

$$-57000 = -1 \times 96500 \times E_{\text{cell}}^{\circ}$$

$$(\because n = \text{electron transferred} = 1)$$

$$E_{\text{cell}}^{\circ} = \frac{57000}{96500} = \mathbf{0.59 \text{ volts}}$$

$$\text{Again } E_{\text{cell}}^{\circ} = \frac{0.0591}{n} \log K_c$$

$$\text{or } E_{\text{cell}}^{\circ} = \frac{0.0591}{n} \log \frac{\text{AgCl}}{[\text{Ag}^{+}][\text{Cl}^{-}]}$$

$$E_{\text{cell}}^{\circ} = \frac{0.0591}{1} \log \left( \frac{1}{K_{\text{sp}}} \right)$$

$$(\because [\text{AgCl(s)}] = 1 \text{ and } K_{\text{sp}} = [\text{Ag}^{+}][\text{Cl}^{-}])$$

$$\text{or } 0.59 = -0.0591 \log K_{\text{sp}}$$

$$\text{or } \log K_{\text{sp}} = -10 \Rightarrow K_{\text{sp}} = \mathbf{10^{-10}}$$

- (b) When Zn is added to 100 ml of saturated AgCl solution.

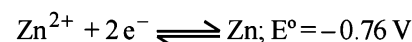
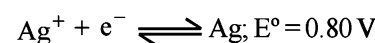

$$E_{\text{cell}}^{\circ} = E_{\text{Ag}^{+}|\text{Ag(s)}}^{\circ} - E_{\text{Zn}^{2+}|\text{Zn(s)}}^{\circ}$$

$$= 0.80 - (-0.76) = 1.56 \text{ V}$$

$$E_{\text{cell}}^{\circ} = \frac{0.059}{n} \log_{10} \frac{[\text{Zn}^{2+}]}{[\text{Ag}^{+}]^2}$$

$$\Rightarrow 1.56 = \frac{0.059}{2} \log_{10} \frac{[\text{Zn}^{2+}]}{[\text{Ag}^{+}]^2}$$

$$\Rightarrow \log_{10} \frac{[\text{Zn}^{2+}]}{[\text{Ag}^{+}]^2} = \mathbf{52.9}$$

**NOTE :** As the value of equilibrium constant is very high so the reaction moves in forward direction completely.

$$[\text{Ag}^{+}] \text{ from (a)} = \sqrt{10^{-10}} = 10^{-5}$$

$$[(\because K_{\text{sp}} = 10^{-10} = [\text{Ag}^{+}][\text{Cl}^{-}])]$$

$$\therefore \text{Ag}^{+} \text{ in 100 ml of solution} = \frac{10^{-5} \times 100}{1000} = \mathbf{10^{-6} \text{ mol.}}$$

38. Given :  $\wedge_m^{\infty}(\text{Ag}^{+}) = 6 \times 10^{-3}$ ;  $\wedge_m^{\infty}(\text{Br}^{-}) = 8 \times 10^{-3}$ ;

$$\wedge_m^{\infty}(\text{NO}_3^{-}) = 7 \times 10^{-3} \text{ and } K_{\text{sp}}(\text{AgBr}) = 12 \times 10^{-14}$$

**NOTE THIS STEP :** To find the specific conductivity ( $\kappa$ ) of the final solution of AgBr in which  $\text{AgNO}_3$  ( $10^{-7} \text{ M}$ ) is mixed we must find the individual  $\kappa$  of the ions.

$$\text{or } \kappa_{\text{soln}} = \kappa_{\text{Ag}^{+}} + \kappa_{\text{Br}^{-}} + \kappa_{\text{NO}_3^{-}}$$

$$\text{Again, } \kappa = \wedge_m^{\infty} \times \text{molar concentration}$$

**Calculation of molar concentration of ions :**

Concentration,

$$[\text{NO}_3^-] = 10^{-7} \text{ moles/l} \equiv 10^{-4} \text{ moles/m}^3$$

Let  $x$  be the molar concentration of  $\text{Ag}^+$  from  $\text{AgBr}$ 

$$\Rightarrow (x + 10^{-7})x = 12 \times 10^{-14}$$

$$\text{or } x^2 + 10^{-7}x - 12 \times 10^{-14} = 0$$

$$\text{or, } (x + 4 \times 10^{-7})(x - 3 \times 10^{-7}) = 0 \Rightarrow x = 3 \times 10^{-7} \text{ M}$$

$$\Rightarrow [\text{Br}^-] = 3 \times 10^{-7} \text{ M} \equiv 3 \times 10^{-4} \text{ moles/m}^3 \text{ and}$$

$$[\text{Ag}^+] = 3 \times 10^{-7} + 10^{-7} = 4 \times 10^{-7} \text{ M} = 4 \times 10^{-4} \text{ moles/m}^3$$

$$\kappa_{\text{Ag}^+} = 6 \times 10^{-3} \times 4 \times 10^{-4}$$

$$= 24 \times 10^{-7} (\text{Sm}^2 \text{mol}^{-1} \times \text{mol/m}^3) = 24 \times 10^{-7} \text{ S/m}$$

$$\text{Similarly, } \kappa_{\text{Br}^-} = 8 \times 10^{-3} \times 3 \times 10^{-4} = 24 \times 10^{-7} \text{ S/m and}$$

$$\kappa_{\text{NO}_3^-} = 7 \times 10^{-3} \times 10^{-4} = 7 \times 10^{-7} \text{ S/m}$$

$$\Rightarrow \kappa = (24 + 24 + 7) \times 10^{-7} \text{ S/m} = 55 \times 10^{-7} \text{ S/m}$$

So the correct answer is 55.

**F. Match the Following**

1. (A - p, s); (B - r); (C - p, q); (D - p).

A  $\rightarrow$  p, s; The reaction is redox reaction because the O.N. of O in  $\text{O}_2^-$  is  $-0.5$  and that in  $\text{O}_2$  is zero. In  $\text{O}_2^{2-}$  is  $-1.0$ . It involves reduction oxidation reaction. Since here a part of molecule is oxidised and a part is reduced so it is disproportionation.

B  $\rightarrow$  r; The structure of  $\text{Cr}_2\text{O}_7^{2-}$  is given below

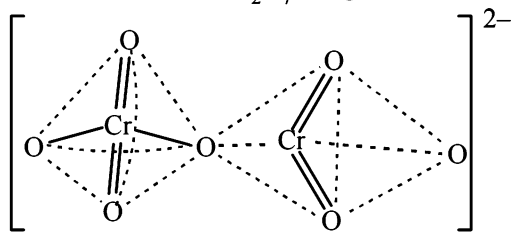

[NOTE : In any solution dichromate ions and chromate ions exist in equilibrium. In alkali solution, dichromate ions are converted into chromate ions and on acidification chromate ions are converted back into dichromate ion.]

C  $\rightarrow$  p, q; The reaction is

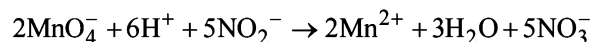

It involves change in O.N of Mn (from  $+7$  in  $\text{MnO}_4^-$  to  $+2$  in  $\text{Mn}^{2+}$ ), So Mn is reduced and  $\text{NO}_2^-$  is oxidised to  $\text{NO}_3^-$  it is a redox reaction.

The structure of  $\text{NO}_3^-$  (one of the products is trigonal planar)

D  $\rightarrow$  p, It is a redox reaction.

2. (a) (P)
- $(\text{C}_2\text{H}_5)_3\text{N} + \text{CH}_3\text{COOH} \longrightarrow$



Initially conductivity increases because on neutralisation ions are created. After that it becomes practically constant because X alone can not form ions.

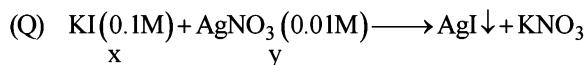

Number of ions in the solution remains constant as only  $\text{AgNO}_3$  precipitated as  $\text{AgI}$ . Thereafter conductance increases due to increase in number of ions.

- (R) Initially conductance decreases due to the decrease in the number of  $\text{OH}^-$  ions as  $\text{OH}^-$  is getting replaced by  $\text{CH}_3\text{COO}^-$  which has poorer conductivity thereafter it slowly increases due to the increase in number of  $\text{H}^+$  ions.
- (S) Initially it decreases due to decrease in  $\text{H}^+$  ions and then increases due to the increase in  $\text{OH}^-$  ions.

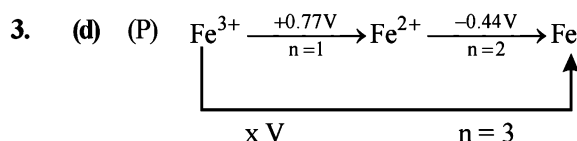

$$\Delta G_{\text{Fe}^{3+}/\text{Fe}}^{\circ} = \Delta G_{\text{Fe}^{3+}/\text{Fe}^{2+}}^{\circ} + \Delta G_{\text{Fe}^{2+}/\text{Fe}}^{\circ}$$

$$\Rightarrow -3 \times \text{FE}_{(\text{Fe}^{3+}/\text{Fe})}^{\circ} = -1 \times \text{FE}_{(\text{Fe}^{3+}/\text{Fe}^{2+})}^{\circ} + (-2 \times \text{FE}_{(\text{Fe}^{2+}/\text{Fe})}^{\circ})$$

$$\Rightarrow 3 \times x = 1 \times 0.77 + 2 \times (-0.44)$$

$$\Rightarrow x = -\frac{0.11}{3} \text{ V} \approx -0.04 \text{ V.}$$

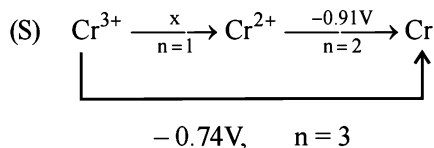
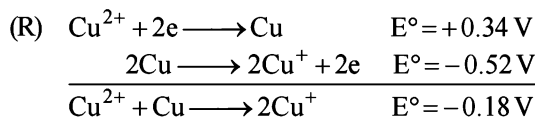
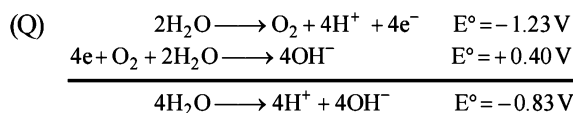

$$x \times 1 + 2 \times (-0.91) = 3 \times (-0.74)$$

$$x - 1.82 = -2.22 \Rightarrow x = -0.4 \text{ V}$$

**G. Comprehension Based Questions**

1. (d) In the given reaction, Ag ions are reduced to Ag and Glucose is oxidised to gluconic acid as per the given reactions,
- $$\text{Ag}^+ + \text{e}^- \longrightarrow \text{Ag}; E_{\text{red}}^{\circ} = +0.800 \text{ V and}$$
- $$\text{C}_6\text{H}_{12}\text{O}_6 + \text{H}_2\text{O} \longrightarrow \text{C}_6\text{H}_{12}\text{O}_7 + 2\text{H}^+ + 2\text{e}^-;$$
- Gluconic acid



$$E_{\text{ox}}^{\circ} = -0.05 \text{ V}$$

$$\text{Hence, } E_{\text{cell}}^{\circ} = 0.8 - 0.05 = 0.75 \text{ V}$$

$$\Delta G_{\text{cell}}^{\circ} = -nFE = -2F \times 0.75 = -RT \ln K$$

$$\Rightarrow \ln K = \frac{2F}{RT} (0.75) = 2 \times 38.92 \times 0.75 = 58.38$$

2. (a) For the reaction,

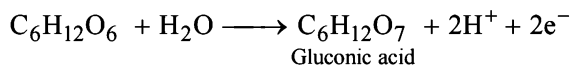

$$E = E^{\circ} - \frac{0.0591}{n} \ln \frac{[\text{P}]}{[\text{R}]} = E^{\circ} - \frac{0.0591}{2} \ln [\text{H}^+]^2$$

$$E - E^{\circ} = -\frac{0.0591}{2} \times 2 \ln(-\text{pH}) = 0.0591 \times 11 = 0.65$$

So,  $E_{\text{oxidation}}$  increases over  $E_{\text{oxidation}}^{\circ}$  by 0.65 V.

3. (b) During Tollen's test, oxidation of silver ion requires an alkaline medium. Under these conditions it forms insoluble silver oxide, hence to dissolve this oxide a complexing agent, ammonia is added, which brings silver ion as diamminesilver (I) ion,  $[\text{Ag}(\text{NH}_3)_2]^+$ . It is a soluble complex.

4. (b) Reaction at anode:  $2\text{Cl}^- \longrightarrow \text{Cl}_2 + 2\text{e}^-$   
moles of  $\text{Cl}^- = 4 \times 500 \times 10^{-3} = 2$

$$\text{moles } \text{Cl}_2 = \frac{1}{2} \times 2 = 1$$

5. (d) 500 ml of 4.0 molar NaCl has 2 mole of NaCl. By electrolysis we can get a maximum of 2 moles of sodium which can combine with exactly 2 moles of mercury to give amalgam.  
 $\therefore$  The maximum weight of amalgam which can be formed from this solution  
= weight of 2 mole of sodium + weight of 2 mole of mercury  
=  $2 \times 23 + 2 \times 200 = 446 \text{ g}$

6. (d)  $\text{Na}^+ + \text{e}^- \longrightarrow \text{Na}$   
Total number of moles of  $\text{Na}^+$  discharged at cathode = 2 mole  
 $\therefore$  The number of electron required for this purpose = 2 mole  
 $\therefore$  Total charge required  
= 2 faraday =  $2 \times 96500 = 193000$  coulombs.

7. (c)  $2\text{I}^- + \text{Cl}_2 \longrightarrow \text{I}_2 + 2\text{Cl}^-$   
 $E^{\circ} = E_{\text{I}^-/\text{I}_2}^{\circ} + E_{\text{Cl}_2/\text{Cl}^-}^{\circ} = -0.54 + 1.36; E^{\circ} = 0.82 \text{ V}$   
 $E^{\circ}$  is positive hence, iodide ion is oxidized by chlorine.

8. (d)  $4\text{Mn}^{3+} + 2\text{H}_2\text{O} \longrightarrow 4\text{Mn}^{2+} + \text{O}_2 + 4\text{H}^+$   
 $E_{\text{Mn}^{3+}/\text{Mn}^{2+}}^{\circ} + E_{\text{H}_2\text{O}/\text{O}_2}^{\circ} = 1.50 + (-1.23) = 0.27 \text{ V}$

Reaction is feasible. [ $\therefore E^{\circ}$  is positive]

9. (a) The precipitate formed in this reaction is of  $\text{Fe}_4[\text{Fe}(\text{CN})_6]_3$

10. (b)  $\text{M}_{(\text{s})} + \text{M}^+_{(\text{aq})1\text{M}} \longrightarrow \text{M}^+_{(\text{aq})0.05\text{M}} + \text{M}_{(\text{s})}$

According to Nernst equation,

$$E_{\text{cell}} = 0 - \frac{2.303RT}{F} \log \frac{\text{M}^+_{0.05\text{M}}}{\text{M}^+_{1\text{M}}}$$

$$= 0 - \frac{2.303RT}{F} \log(5 \times 10^{-2}) = +ve$$

Hence,  $|E_{\text{cell}}| = E_{\text{cell}} = 0.70 \text{ V}$  and  $\Delta G < 0$  for the feasibility

of the reaction.

11. (c) From above equation  $\frac{2.303RT}{F} = 0.0538$

$$\text{So, } E_{\text{cell}} = E_{\text{cell}}^{\circ} - \frac{0.0538}{1} \log 0.0025$$

$$= 0 - \frac{0.0538}{1} \log 0.0025 \approx 0.13988 \text{ V} \approx 140 \text{ mV}$$

12. (d) At anode:  $\text{M}(\text{s}) + 2\text{X}^- (\text{aq}) \longrightarrow \text{MX}_2(\text{aq}) + 2\text{e}^-$

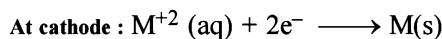

Thus, here  $n = 2$

$$\Delta G = -nFE_{\text{cell}}^{\circ} = -2 \times 96500 \times 0.059 \times 10^{-3} \text{ kJ/mole} = -11.4 \text{ kJ/mole}$$

13. (b)  $\text{M}|\text{M}^{2+} (\text{aq}) || \text{M}^{2+} (\text{aq}) |\text{M}$   
0.001 M

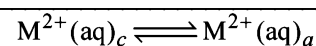
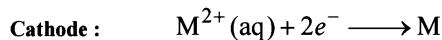
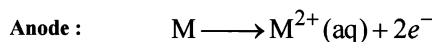

$$E_{\text{cell}} = 0 - \frac{0.059}{2} \log \left\{ \frac{\text{M}^{2+} (\text{aq})_{\text{a}}}{10^{-3}} \right\}$$

$$\Rightarrow 0.059 = -\frac{0.059}{2} \log \left\{ \frac{\text{M}^{2+} (\text{aq})_{\text{a}}}{10^{-3}} \right\}$$

$$-2 = \log \left\{ \frac{\text{M}^{2+} (\text{aq})_{\text{a}}}{10^{-3}} \right\}$$

$$\Rightarrow 10^{-2} \times 10^{-3} = \text{M}^{2+} (\text{aq})_{\text{a}} = \text{solubility} = s$$

$$\Rightarrow K_{\text{sp}} = 4s^3 = 4 \times (10^{-5})^3 = 4 \times 10^{-15}$$

### I. Integer Value Correct Type

1. (4)  $\text{X} \longrightarrow \text{Y}; \quad \Delta G^{\circ} = -193 \text{ kJ mol}^{-1}$

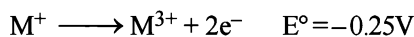

Hence  $\Delta G^{\circ}$  for oxidation will be

$$\Delta G^{\circ} = -nFE^{\circ} = -2 \times 96500 \times (-0.25) = 48250 \text{ J} = 48.25 \text{ kJ}$$

48.25 kJ energy oxidises one mole  $\text{M}^+$

$$\therefore 193 \text{ kJ energy oxidises } \frac{193}{48.25} \text{ mole } \text{M}^+ = 4 \text{ mole } \text{M}^+$$

2. (3)  $1 \rightarrow \text{HX}$

$$\alpha_1 = \frac{(\lambda_m)_{\text{HX}}}{\lambda_m^{\circ}}$$

$$\alpha_2 = \frac{(\lambda_m)_{\text{HY}}}{\lambda_m^{\circ}}$$

$$K_{\text{a1}} = C_1 \alpha_1^2$$

$$K_{\text{a2}} = C_2 \alpha_2^2$$

$$= 0.01 \frac{(\lambda_m)_{\text{HX}}^2}{(\lambda_m^{\circ})^2}$$

$$= 0.1 \frac{(\lambda_m)_{\text{HY}}^2}{(\lambda_m^{\circ})^2}$$

$$\therefore \frac{K_{\text{a1}}}{K_{\text{a2}}} = \frac{0.01 (\lambda_m)_{\text{HX}}^2}{0.1 (\lambda_m)_{\text{HY}}^2} = 0.1 \left( \frac{(\lambda_m)_{\text{HX}}}{(\lambda_m)_{\text{HY}}} \right)^2$$

$$= 0.1 \left( \frac{1}{10} \right)^2 = 10^{-3}$$

$$\text{p}K_{\text{a}}(\text{HX}) - \text{p}K_{\text{a}}(\text{HY}) = -\log \frac{K_{\text{a1}}}{K_{\text{a2}}} = -\log 10^{-3} = 3$$

## Section-B

# JEE Main/ AIEEE

1. (b) given  $S \propto \frac{\text{area} \times \text{conc}}{\ell} = \frac{\text{km}^2 \text{mol}}{\text{m} \times \text{m}^3} \therefore \kappa = \text{Sm}^2 \text{mol}^{-1}$

2. (c)  $E_{\text{cell}} = \text{Reduction potential of cathode (right)} - \text{Reduction potential of anode (left)}$

$$= E_{\text{right}} - E_{\text{left}}$$

3. (b) Oxidation half cell:-

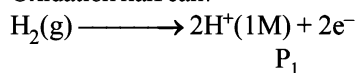

Reduction half cell

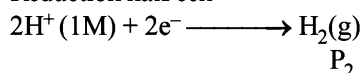

The net cell reaction

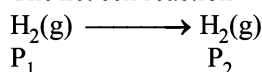

$$E_{\text{cell}}^{\circ} = 0.00 \text{ V} \qquad n = 2$$

$$\therefore E_{\text{cell}} = E_{\text{cell}}^{\circ} - \frac{RT}{nF} \log_e K = 0 - \frac{RT}{nF} \log_e \frac{P_2}{P_1}$$

$$\text{or } E_{\text{cell}} = \frac{RT}{2F} \log_e \frac{P_2}{P_1}$$

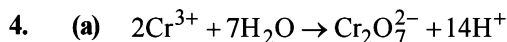

O.S. of Cr changes from +3 to +6 by loss of electrons. At anode oxidation takes place.

5. (d) Pure metal always deposits at cathode.

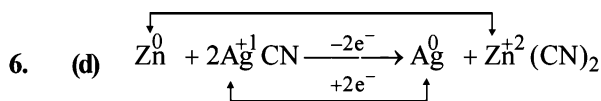

The oxidation state shows a change only in (d)

7. (c) The equilibrium constant is related to the standard emf of cell by the expression

$$\log K = E_{\text{cell}}^{\circ} \times \frac{n}{0.059} = 0.295 \times \frac{2}{0.059}$$

$$\log K = \frac{590}{59} = 10 \text{ or } K = 1 \times 10^{10}$$

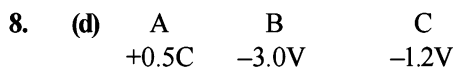

**NOTE :** The higher the negative value of reduction potential, the more is the reducing power.

Hence  $B > C > A$ .

9. (a) When 96500 coulomb of electricity is passed through the electroplating bath the amount of Ag deposited = 108g

$\therefore$  when 9650 coulomb of electricity is passed deposited Ag.

$$= \frac{108}{96500} \times 9650 = 10.8 \text{ g}$$

10. (b)  $E_{\text{cell}} = E_{\text{cell}}^{\circ} + \frac{0.059}{n} \log \frac{[\text{Cu}^{+2}]}{[\text{Zn}^{+2}]}$

$$= 1.10 + \frac{0.059}{2} \log [0.1] = 1.10 - 0.0295 = 1.07 \text{ V}$$

11. (b) Magnesium provides cathodic protection and prevent rusting or corrosion.

12. (b) In  $\text{H}_2 - \text{O}_2$  fuel cell, the combustion of  $\text{H}_2$  occurs to create potential difference between the two electrodes

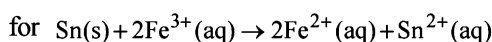
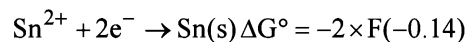
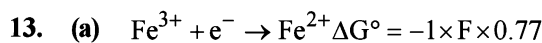

$\therefore$  Standard potential for the given reaction

$$\text{or } E_{\text{cell}}^{\circ} = E_{\text{Sn}/\text{Sn}^{2+}}^{\circ} + E_{\text{Fe}^{3+}/\text{Fe}^{2+}}^{\circ} = 0.14 + 0.77 = 0.91 \text{ V}$$

14. (a)  $E_{\text{cell}}^{\circ} = E_{\text{cell}}^{\circ} - \frac{0.059}{n} \log K_c$

$$\text{or } 0 = 0.591 - \frac{0.0591}{1} \log K_c$$

$$\text{or } \log K_c = \frac{0.591}{0.0591} = 10 \text{ or } K_c = 1 \times 10^{10}$$

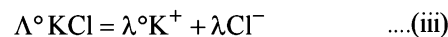
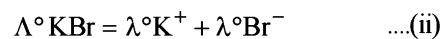

operating (i) + (ii) - (iii)



$$= 126 + 152 - 150 = 128 \text{ S cm}^2 \text{ mol}^{-1}$$

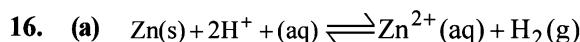

$$E_{\text{cell}} = E_{\text{cell}}^{\circ} - \frac{0.059}{2} \log \frac{[\text{Zn}^{2+}][\text{H}_2]}{[\text{H}^+]^2}$$

Addition of  $\text{H}_2\text{SO}_4$  will increase  $[\text{H}^+]$  and  $E_{\text{cell}}$  will also increase and the equilibrium will shift towards RHS

17. (c) The given values show that Cr has maximum oxidation potential, therefore its oxidation will be easiest. (Change the sign to get the oxidation values)

18. (d) **NOTE :** For spontaneous reaction  $\Delta G$  should be negative. Equilibrium constant should be more than one

( $\Delta G = -2.303 \text{ RT} \log K_c$ , If  $K_c = 1$  then  $\Delta G = 0$ ; If  $K_c < 1$  then  $\Delta G = +ve$ ). Again  $\Delta G = -nFE_{\text{cell}}^{\circ}$ .

$E_{\text{cell}}^{\circ}$  must be +ve to have  $\Delta G -ve$ .

19. (a) Thus difluoro acetic acid being strongest acid will furnish maximum number of ions showing highest electrical conductivity. The decreasing acidic strength of the carboxylic acids given is difluoro acetic acid > fluoro acetic acid > chloro acetic acid > acetic acid.

20. (d) 1 mole of  $e^- = 1F = 96500\text{ C}$   
27g of Al is deposited by  $3 \times 96500\text{ C}$   
5120 g of Al will be deposited by

$$= \frac{3 \times 96500 \times 5120}{27} = 5.49 \times 10^7\text{ C}$$

21. (b)  $\Lambda_{\text{HCl}}^\infty = 426.2$  (i)

$\Lambda_{\text{AcONa}}^\infty = 91.0$  (ii)

$\Lambda_{\text{NaCl}}^\infty = 126.5$  (iii)

$$\Lambda_{\text{AcOH}}^\infty = (\text{i}) + (\text{ii}) - (\text{iii}) = [426.2 + 91.0 - 126.5] = 390.7$$

22. (c)  $2\text{HI}^{-1} + \text{H}_2\text{SO}_4^{+6} \longrightarrow \text{I}_2^0 + \text{SO}_2^{+4} + 2\text{H}_2\text{O}$  in this reaction oxidation number of S is decreasing from +6 to +4 hence undergoing reduction and for HI oxidation number of I is increasing from -1 to 0 hence undergoing oxidation therefore  $\text{H}_2\text{SO}_4$  is acting as oxidising agent.

23. (b)  $\Lambda_{\text{CH}_3\text{COOH}}^\circ$  is given by the following equation

$$\Lambda_{\text{CH}_3\text{COOH}}^\circ = (\Lambda_{\text{CH}_3\text{COONa}}^\circ + \Lambda_{\text{HCl}}^\circ) - (\Lambda_{\text{NaCl}}^\circ)$$

Hence  $\Lambda_{\text{NaCl}}^\circ$  is required.

24. (b)  $R = 100\ \Omega$ ,  $\kappa = \frac{1}{R} \left( \frac{l}{a} \right)$ ,  $\frac{l}{a}$  (cell constant) =  $1.29 \times 100\text{ m}^{-1}$

Given,  $R = 520\ \Omega$ ,  $C = 0.2\text{ M}$ ,  $\mu$  (molar conductivity) = ?

$$\mu = \kappa \times V \quad (\kappa \text{ can be calculated as } \kappa = \frac{1}{R} \left( \frac{l}{a} \right))$$

now cell constant is known.)

Hence,

$$\mu = \frac{1}{520} \times 129 \times \frac{1000}{0.2} \times 10^{-6}\text{ m}^3 = 12.4 \times 10^{-4}\text{ Sm}^2\text{ mol}^{-1}$$

25. (b) NOTE : According to Kohlrausch's law, molar conductivity of weak electrolyte acetic acid ( $\text{CH}_3\text{COOH}$ ) can be calculated as follows:

$$\Lambda_{\text{CH}_3\text{COOH}}^\circ = (\Lambda_{\text{CH}_3\text{COONa}}^\circ + \Lambda_{\text{HCl}}^\circ) - \Lambda_{\text{NaCl}}^\circ$$

$\therefore$  Value of  $\Lambda_{\text{NaCl}}^\circ$  should also be known for calculating value of  $\Lambda_{\text{CH}_3\text{COOH}}^\circ$ .

26. (d)  $E_{\text{cell}} = 0$ ; when cell is completely discharged.

$$E_{\text{cell}} = E_{\text{cell}}^\circ - \frac{0.059}{2} \log \left( \frac{[\text{Zn}^{2+}]}{[\text{Cu}^{2+}]} \right)$$

$$\text{or } 0 = 1.1 - \frac{0.059}{2} \log \left( \frac{[\text{Zn}^{2+}]}{[\text{Cu}^{2+}]} \right)$$

$$\log \left( \frac{[\text{Zn}^{2+}]}{[\text{Cu}^{2+}]} \right) = \frac{2 \times 1.1}{0.059} = 37.3 \quad \therefore \left( \frac{[\text{Zn}^{2+}]}{[\text{Cu}^{2+}]} \right) = 10^{37.3}$$

27. (d) From the given representation of the cell,  $E_{\text{cell}}$  can be found as follows.

$$E_{\text{cell}} = E_{\text{Fe}^{2+}/\text{Fe}}^\circ - E_{\text{Cr}^{3+}/\text{Cr}}^\circ - \frac{0.059}{6} \log \frac{[\text{Cr}^{3+}]^2}{[\text{Fe}^{2+}]^3}$$

[Nernst -Equ.]

$$= -0.42 - (-0.72) - \frac{0.059}{6} \log \frac{(0.1)^2}{(0.01)^3}$$

$$= -0.42 + 0.72 - \frac{0.059}{6} \log \frac{0.1 \times 0.1}{0.01 \times 0.01 \times 0.01}$$

$$= 0.3 - \frac{0.059}{6} \log \frac{10^{-2}}{10^{-6}} = 0.3 - \frac{0.059}{6} \times 4$$

$$= 0.30 - 0.0393 = 0.26\text{ V}$$

Hence option (d) is correct answer.

28. (c)  $\text{CH}_3\text{OH}(l) + \frac{3}{2}\text{O}_2(g) \rightarrow \text{CO}_2(g) + 2\text{H}_2\text{O}(l)$

$$\Delta G_r = \Delta G_f(\text{CO}_2, g) + 2\Delta G_f(\text{H}_2\text{O}, l) -$$

$$\Delta G_f(\text{CH}_3\text{OH}, l) - \frac{3}{2}\Delta G_f(\text{O}_2, g)$$

$$= -394.4 + 2(-237.2) - (-166.2) - 0$$

$$= -394.4 - 474.4 + 166.2 = -702.6\text{ kJ}$$

$$\% \text{ efficiency} = \frac{702.6}{726} \times 100 = 97\%$$

29. (b) Given

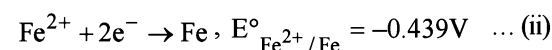
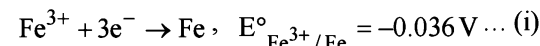

we have to calculate

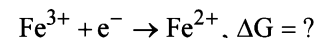

To obtain this equation subtract equ (ii) from (i) we get

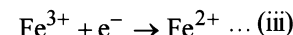

As we know that  $\Delta G = -nFE$

Thus for reaction (iii)

$$\Delta G = \Delta G_1 - \Delta G_2; \quad -nFE^\circ = -nFE_1 - (-nFE_2)$$

$$-nFE^\circ = nFE_2 - nFE_1$$

$$-1FE^\circ = 2 \times 0.439F - 3 \times 0.036F$$

$$-1FE^\circ = 0.770F \quad \therefore E^\circ = -0.770\text{ V}$$

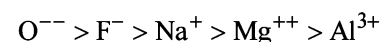

30. (c)  $\Delta G = -nFE$

$$\text{or } E = \frac{\Delta G}{-nF} = \frac{966 \times 10^3}{4 \times 96500} = -2.5 \text{ V}$$

$\therefore$  The potential difference needed for the reduction = 2.5 V.

31. (a) The value of  $E_{M^{2+}/M}^\circ$  for given metal ions are

$$E_{Mn^{2+}/Mn}^\circ = -1.18 \text{ V}, E_{Cr^{2+}/Cr}^\circ = -0.9 \text{ V},$$

$$E_{Fe^{2+}/Fe}^\circ = -0.44 \text{ V} \text{ and } E_{Co^{2+}/Co}^\circ = -0.28 \text{ V}.$$

The correct order of  $E_{M^{2+}/M}^\circ$  values without considering negative sign would be

$$Mn^{2+} > Cr^{2+} > Fe^{2+} > Co^{2+}.$$

32. (c)  $H^+ + e^- \longrightarrow \frac{1}{2}H_2$ ;  $E = E^\circ - \frac{0.059}{1} \log \frac{P_{H_2}^{1/2}}{[H^+]}$

Now if  $P_{H_2} = 2$  atm and  $[H^+] = 1M$

$$\text{then } E = 0 - \frac{0.059}{1} \log \frac{2^{1/2}}{1} = -2$$

33. (d) For a spontaneous reaction  $\Delta G$  must be -ve  
Since  $\Delta G = -nFE^\circ$

Hence for  $\Delta G$  to be -ve  $\Delta E^\circ$  has to be positive. Which is possible when  $X = Zn$ ,  $Y = Ni$

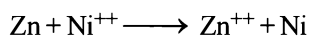

$$E_{Zn/Zn^{2+}}^\circ + E_{Ni^{2+}/Ni}^\circ = 0.76 + (-0.23) = +0.53$$

(positive)

34. (d) higher the value of standard reduction potential stronger will be the oxidising agent, hence  $MnO_4^-$  is the strongest oxidising agent.

35. (a) Given for 0.2 M solution

$$R = 50 \Omega$$

$$\kappa = 1.4 \text{ S m}^{-1} = 1.4 \times 10^{-2} \text{ S cm}^{-1}$$

$$\text{Now, } R = \rho \frac{\ell}{a} = \frac{1}{\kappa} \times \frac{\ell}{a}$$

$$\Rightarrow \frac{\ell}{a} = R \times \kappa = 50 \times 1.4 \times 10^{-2}$$

For 0.5 M solution

$$R = 280 \Omega ; \kappa = ?$$

$$\frac{\ell}{a} = 50 \times 1.4 \times 10^{-2} \Rightarrow R = \rho \frac{\ell}{a} = \frac{1}{\kappa} \times \frac{\ell}{a}$$

$$\Rightarrow \kappa = \frac{1}{280} \times 50 \times 1.4 \times 10^{-2}$$

$$= \frac{1}{280} \times 70 \times 10^{-2} = 2.5 \times 10^{-3} \text{ S cm}^{-1}$$

$$\text{Now, } \Lambda_m = \frac{\kappa \times 1000}{M} = \frac{2.5 \times 10^{-3} \times 1000}{0.5}$$

$$= 5 \text{ S cm}^2 \text{ mol}^{-1} = 5 \times 10^{-4} \text{ S m}^2 \text{ mol}^{-1}$$

36. (a) (a)  $Mn^{2+} + 2e^- \rightarrow Mn$ ;  $E^\circ = -1.18V$ ; ... (i)

(b)  $Mn^{3+} + e^- \rightarrow Mn^{2+}$ ;  $E^\circ = -1.51V$ ; ... (ii)

Now multiplying equation (ii) by two and subtracting from equation (i)



$$E^\circ = E_{Ox.} + E_{Red.} = -1.18 + (-1.51) = -2.69 \text{ V}$$

[-ve value of EMF (i.e.,  $\Delta G = +ve$ ) shows that the reaction is non-spontaneous]

37. (c) According to Debye Huckle onsager equation,

$$\lambda_C = \lambda_\infty - B\sqrt{C}$$

38. (d)  $Cu^{2+} + 2e^- \longrightarrow Cu$

2F i.e.  $2 \times 96500$  C deposit  $Cu = 1 \text{ mol} = 63.5 \text{ g}$

39. (b) **Galvanization** is the process by which zinc is coated over corrosive (easily rusted) metals to prevent them from corrosion.

14

# Chemical Kinetics & Nuclear Chemistry

## Section-A : JEE Advanced/ IIT-JEE

- A** 1.  $A^{-4}_Z M$       2. Product of active masses of reactants at that temperature  
 3. 8      4. acidic, first (or basic, second)      5. isotope  
 6.  $1.765 \times 10^{-4}$  kg/hr      7. very high temperature or zero activation energy
- B** 1. T    2. F    3. F    4. F    5. F
- C** 1. (b)    2. (a)    3. (d)    4. (c)    5. (d)    6. (d)    7. (b)    8. (b)    9. (d)    10. (d)  
 11. (b)    12. (a)    13. (c)    14. (a)    15. (c)    16. (d)    17. (b)    18. (d)    19. (c)    20. (a)  
 21. (d)    22. (a)    23. (a)    24. (d)    25. (b)
- D** 1. (b, c)    2. (b, c)    3. (a, d)    4. (a, d)    5. (a, b, d)    6. (a, b, d)    7. (a, b)    8. (b, c, d)    9. (b, d)
- E** 1. 1, 0, 1.386 min    2.  $1.2 \times 10^{-4}$  yrs $^{-1}$ , 1/4    3. first order  
 4. 7, 6    5. 5.2%, 128.33 hours    6.  $0.0231 \text{ min}^{-1}$ ,  $43.848 \text{ kJ mol}^{-1}$     7.  $3.451 \times 10^{-18}$  mol  
 8. 311.35 K    9.  $5.2 \times 10^{-3} \text{ min}^{-1}$     10.  $3.267 \times 10^{-2} \text{ min}^{-1}$     11.  $5.624 \times 10^5$  atoms  
 12. 67.17%    13. 0.749 atm    14. (i) 2, (ii) 1.2 M, (iii) 0.1 mol//hr  
 15. (i) 2, 1; (ii)  $2.66 \times 10^8 \text{ mol}^{-2} \text{ l}^2 \text{ s}^{-1}$ ; (iii)  $5.54 \times 10^4 \text{ J}$ ; (iv)  $1.175 \times 10^{18} \text{ l}^2 \text{ mol}^{-2} \text{ sec}$     16. 0.061  $\mu\text{g}$   
 17. 20.34 min    18.  $3.81 \times 10^{-4} \text{ yr}^{-1}$ ,  $3.14 \times 10^{-2} \text{ yr}^{-1}$     19.  $6.07 \times 10^5$   
 20. (i)  $239 \text{ kJ mol}^{-1}$ , (ii) 669 K    22.  $5.42 \times 10^{10} \text{ sec}^{-1}$ ,  $2.2 \times 10^4 \text{ mol}^{-1}$   
 23.  $3.4354 \times 10^{-3} \text{ M min}^{-1}$     24.  $7.097 \times 10^8 \text{ yrs}$     25.  $100 \text{ kJ mol}^{-1}$   
 26. 24.14 min    27.  $1.005 \times 10^{-4} \text{ min}^{-1}$     29. (a)  $R_0 = k[A_0]$ ; (b)  $0.5 \text{ sec}^{-1}$   
 31. (i) 1, (ii)  $6.93 \times 10^{-3} \text{ min}^{-1}$ , (iii) 200 min, (iv) 950 mm Hg
- G** 1. (c)      2. (b)      3. (a)
- H** 1. (a)
- I** 1. 8      2. 5      3. 3      4. 9      5. 8      6. 9      7. 8

## Section-B : JEE Main/ AIEEE

1. (a)    2. (b)    3. (d)    4. (d)    5. (a)    6. (c)    7. (b)  
 8. (d)    9. (b)    10. (c)    11. (b)    12. (c)    13. (d)    14. (b)  
 15. (a)    16. (b)    17. (d)    18. (d)    19. (b)    20. (c)    21. (a)  
 22. (c)    23. (c)    24. (b)    25. (a)    26. (b)    27. (a)    28. (b)  
 29. (b)    30. (b)    31. (c)    32. (d)    33. (c)    34. (b)    35. (a)  
 36. (d)    37. (c)    38. (d)

## Section-A JEE Advanced/ IIT-JEE

### A. Fill in the Blanks

1. A-4

#### TIPS/Formulae :

When an element emits  $\alpha$ -particle atomic mass decreases by four and atomic number decreases by two. Loss of  $\beta$ -particle results in increase in atomic number by 1 and no change in atomic mass.

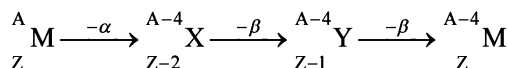

2. Product of active masses of reactants at that time

3. 8;  ${}^{14}_6\text{C} \rightarrow {}^{14}_7\text{N} + {}^0_{-1}\text{e}$ . 2 particles.

NOTE : Due to emission of the  $\beta$  particle atomic number increases by 1.

4. acidic, first (or basic, second).

5. Isotope; (because new atom has same atomic number but different atomic mass). [Refer to Q. 1 above]

6.  $1.765 \times 10^{-4}$  kg/hr;

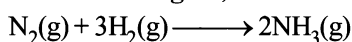

Here Rate of reaction =  $\frac{1}{3}$  [Rate of disappearance of  $\text{H}_2$ ] =

$\frac{1}{2}$  [Rate of appearance of  $\text{NH}_3$ ]

$$\text{or } \frac{1}{3} \frac{d[\text{H}_2]}{dt} = \frac{1}{2} \frac{d[\text{NH}_3]}{dt} \Rightarrow \frac{d[\text{H}_2]}{dt} = \frac{3}{2} \frac{d[\text{NH}_3]}{dt}$$

$$\frac{d[\text{NH}_3]}{dt} = 0.01 \text{ kg/hr} = \frac{0.001}{17} \times 1000 = \frac{1}{17} \text{ mole/hr}$$

$$\therefore \frac{d[\text{H}_2]}{dt} = \frac{1}{17} \times \frac{3}{2} = \frac{3}{34} \text{ mole/hr} = \frac{3}{34} \times \frac{2}{1000} \text{ kg/hr} \\ = 1.765 \times 10^{-4} \text{ kg/hr.}$$

7. very high temperature ( $T=\infty$ ) or zero activation energy.

### B. True/False

- True : The rate of reaction of first order is directly proportional to the concentration of reacting substance.
- False : Catalyst does not make a reaction more exothermic, but decreases the activation energy and hence increase the rate of reaction.
- False : Catalyst lowers the energy of activation and therefore influences the rate as well as rate constant of the reaction.
- False : In  $\beta$ -emission ( ${}_{-1}^0\text{e}$ ) the atomic number of the daughter nuclei increases by 1.
- True : The rate of a reaction increases with increase in temperature because at higher temperature more number of molecules attain the activation energy.

### C. MCQs with One Correct Answer

- (b)  ${}_{92}\text{U}^{238} \rightarrow {}_{90}\text{U}^{234} + {}^4_2\text{He}$   
( $\alpha$ -particle)
- (a) It is a constant of a particular reaction at a given temperature. It does not depend upon initial concentration of the reactants, time of reaction and extent of reaction.
- (d) It is a characteristic constant of a particular reaction at a given temperature. It does not depend upon initial concentration of the reactants, time of reaction and extent of reaction.
- (c) A catalyst decreases the activation energy of the reactants and thus shortens time of reaction. So (c) is the correct option.
- (d) NOTE :  $\alpha$ - and  $\beta$ -rays, made up of positively & negatively charged particles and are deflected by a magnetic field in opposite directions;  $\gamma$ -rays remain undeflected. (as they do not have charge).
- (d) TIPS/Formulae :

$$N = N_0 \left(\frac{1}{2}\right)^n$$

where,  $N$  = Amount of radioactive substance which is left after certain number of half-life periods ( $n$ )

$N_0$  = Initial amount of radioactive substance.

$$\text{No. of half-lives} = \frac{\text{total time}}{\text{half life period}} = \frac{560}{140} = 4$$

In ' $n$ ' half-lives, the element will reduce to

$$\left(\frac{1}{2}\right)^n \times \text{Initial wt.} = \left(\frac{1}{2}\right)^4 \times 1 = \frac{1}{16} \text{ g}$$

- (b) The Arrhenius equation is :  $k = A \exp(-E_a/RT)$   
As  $T \rightarrow \infty$ ,  $\exp(-E_a/RT) \rightarrow 1$ . Hence,  $k = A$   
where  $A$ , the Arrhenius parameter, is  $6.0 \times 10^{14} \text{ s}^{-1}$   
[NOTE : ' $A$ ' is also known as frequency factor]
- (b) The species  ${}_{13}\text{Al}^{29}$  (No. of neutrons = 16) contains more neutrons than the stable isotope  ${}_{13}\text{Al}^{27}$  (No. of neutrons = 14).

Neutron on decomposition shows  $\beta$ -emission.

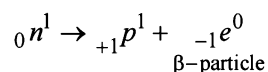

- (d) TIPS/Formulae :  
The sum of mass number and atomic numbers of reactants = The sum of mass number and atomic no. of products in a nuclear reaction.  
The given nuclear fission reaction is  
$${}^{235}_{92}\text{U} + {}^1_0n \rightarrow {}^{139}_{54}\text{Xe} + {}^{94}_{38}\text{Sr} + 3{}^1_0n$$

**10. (d) TIPS/Formulae :**

Find the order of reaction and then use appropriate equation.

As unit of  $k$  is  $\text{sec}^{-1}$ , reaction is of **first order**,

$$r = k[\text{N}_2\text{O}_5]; \therefore [\text{N}_2\text{O}_5] = \frac{2.4 \times 10^{-5}}{3 \times 10^{-5}} = 0.8 \text{ mol/L}$$

**11. (b) NOTE :** The rate of photochemical process varies with the intensity of absorption.

Since greater the intensity of absorbed light more photons will fall at a point, and further each photon causes one molecule to undergo reaction.

**12. (a) NOTE :** Individual rates of reactants and products become equal when each of these is divided by their respective stoichiometric coefficient. With time concentration of reactants decreases and is represented by negative sign whereas concentration of products increases and is represented by positive sign.

The given reaction is

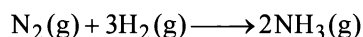

$\therefore$  Correct relationship amongst the rate expression is shown in (a)

**13. (c) TIPS/Formulae :**

$$k = \frac{2.303}{t} \log \frac{[A]_0}{[A]_t}$$

$$\therefore k = \frac{2.303}{2 \times 10^4} \log \frac{800}{50} = 1.386 \times 10^{-4} \text{ s}^{-1}$$

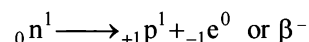
**14. (a)  $n/p$  ratio of  $^{24}\text{Na}$  nuclide is 13/11 i.e. greater than unity and hence  $^{24}\text{Na}$  is radioactive. To achieve stability, it would tend to adjust its  $n/p$  ratio to the proper value of unity. This can be done by breaking a neutron into proton and electron.**

**NOTE :** The proton will stay inside the nucleus whereas electron which cannot exist in the nucleus, will be emitted out as  $\beta$ -ray.

**15. (c) TIPS/Formulae :**

For first order reaction,

$$\text{Rate} = k [\text{conc. of reactant}]$$

Since 0.1 M of  $X$  changes to 0.025 M in 40 minutes,

$$t_{1/2} \text{ of reaction} = 40/2 = 20 \text{ minutes}$$

Rate of reaction of

$$\begin{aligned} X = k[X] &= \frac{0.693}{t_{1/2}} \times [X] = \frac{0.693}{20} \times 0.01 \\ &= 3.47 \times 10^{-4} \text{ M min}^{-1} \end{aligned}$$

**16. (d) Order of a reaction can be fractional. Rest of all are true.**

[NOTE : Order of a reaction can be determined experimentally]

**17. (b) The required reaction is**

From the given equations, we have

$$k_1 = \frac{[\text{Ag}(\text{NH}_3)]^+}{[\text{Ag}^+][\text{NH}_3]}; k_2 = \frac{[\text{Ag}(\text{NH}_3)_2]^+}{[\text{Ag}(\text{NH}_3)]^+[\text{NH}_3]}$$

$\therefore$  The value of  $K$  is given by

$$K = k_1 \times k_2 = 6.8 \times 10^{-3} \times 1.6 \times 10^{-3} = 1.08 \times 10^{-5}$$

**18. (d) TIPS/Formulae :**

Overall order = sum of orders w.r.t each reactant.

Let the order be  $x$  and  $y$  for G and H respectively

Exp.No.	[G]mole litre <sup>-1</sup>	[H]mole litre <sup>-1</sup>	rate(mole litre <sup>-1</sup> time <sup>-1</sup> )
1	$a$	$b$	$r$
2	$2a$	$2b$	$8r$
3	$2a$	$b$	$2r$

Applying  $r = k [\text{G}]^x [\text{H}]^y$  we get,  $x = 1, y = 2$

$\therefore$  For (1) and (3), the rate is doubled when conc. of G is doubled keeping that of H constant i.e.,  $\text{rate} \propto [\text{G}]$

$\therefore x = 1$

From (2) and (3),  $y = 2 \therefore$  Overall order is 3.

**19. (c)  $^{23}_{11}\text{Na} \longrightarrow ^{23}_{10}\text{X} + ^0_1\beta$** 
**20. (a) The values of rate constants  $k_0, k_1$  for zero order and first order reaction, respectively, are given by the following equation:**

$$k_0 = \frac{A_0}{2 \times t_{1/2}} \quad [\text{where } A_0 = \text{initial concentration, and } t_{1/2} = \text{half-life period}]$$

$$\text{and } k_1 = \frac{0.693}{t_{1/2}}$$

substituting various given values, we get

$$k_0 = \frac{1.386 \text{ mol litre}^{-1}}{2 \times 20 \text{ sec}} \quad \dots \text{(i)}$$

$$\text{and } k_1 = \frac{0.693}{40 \text{ sec}} \quad \dots \text{(ii)}$$

Dividing (ii) by (i), we get

$$\frac{k_1}{k_0} = \frac{0.693}{40} \times \frac{2 \times 20}{1.386} \text{ mol}^{-1} \text{ litre}$$

$$= \frac{0.693}{1.386} \text{ mol}^{-1} \text{ litre} = 0.5 \text{ mol}^{-1} \text{ litre}$$

$$= 0.5 \text{ mol}^{-1} \text{ dm}^3 \quad [1 \text{ litre} = 1 \text{ dm}^3]$$

Thus the correct answer is (a).

**21. (d)  $\log k = \log A - \frac{E_a}{2.303RT}$  ... (1)**

$$\text{Also given } \log k = 6.0 - (2000) \frac{1}{T} \quad \dots(2)$$

On comparing equations, (1) and (2)

$$\log A = 6.0 \Rightarrow A = 10^6 \text{ s}^{-1}$$

$$\text{and } \frac{E_a}{2.303 R} = 2000 ;$$

$$\Rightarrow E_a = 2000 \times 2.303 \times 8.314 = 38.29 \text{ kJ mol}^{-1}$$

22. (a) As per Arrhenius equation ( $k = Ae^{-E_a/RT}$ ), the rate constant increases exponentially with temperature.

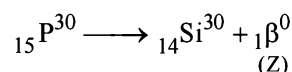
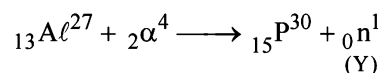
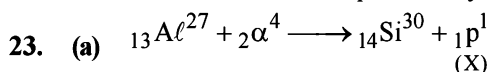

24. (d) For P, if  $t_{50\%} = x$  then  $t_{75\%} = 2x$

This is true only for first order reaction.

So, order with respect to P is 1.

Further the graph shows that concentration of Q decreases with time. So rate, with respect to Q, remains constant. Hence, it is zero order wrt Q.

So, overall order is  $1 + 0 = 1$

25. (b)  $M \rightarrow N$

$$r = k [M]^x$$

when  $M = 2M$ ;  $r = 8r$ , thus

$$8r = k[2M]^x$$

$$8 = (2)^x$$

$$x = 3$$

#### D. MCQs with One or More Than One Correct

1. (b, c) A catalyst provides a new path of lower activation energy. The catalyst reacts with the reactants to form an intermediate of low activation energy. The intermediate then decomposes to form the products along with regeneration of catalyst. Thus the reaction mechanism changes completely.

2. (b, c) As rate  $= k [RCl]$ , so it is first order reaction. On decreasing the concentration of RCl to half, the rate will also be halved. Rate will also increase with temperature.

3. (a, d) TIPS/Formulae :

Balance various given nuclear reactions.

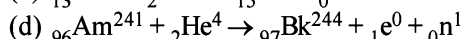
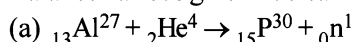

4. (a, d) In first order reaction, if  $\alpha$  is the degree of dissociation then

$$kt = \log_e \frac{1}{(1-\alpha)} = -\log_e (1-\alpha) \text{ or } e^{-kt} = 1-\alpha$$

$$\therefore \alpha = 1 - e^{-kt}$$

The Arrhenius equation is,  $k = Ae^{-E_a/RT}$

Plot of reciprocal concentration of the reactant vs time is linear. Dimensions of pre-exponential factor 'A' are equivalent to dimensions of  $k$ , which is  $T^{-1}$  for a first order reaction.

5. (a, b, d) The relevant expressions are as follows.

$$\text{Choice (a)} \quad \log K_p = -\frac{\Delta H}{R} \frac{1}{T} + I$$

$$\text{Choice (b)} \quad \log [X] = \log [X]_0 + kt$$

$$\text{Choice (c)} \quad P/T = \text{constant} \quad (V \text{ constant})$$

$$\text{Choice (d)} \quad PV = \text{constant} \quad (T \text{ constant}).$$

6. (a, b, d)

For first order reaction

$$[A] = [A]_0 e^{-kt}$$

Hence concentration of  $[\text{NO}_2]$  decreases exponentially.

Also,  $t_{1/2} = \frac{0.693}{K}$ . Which is independent of concentration and  $t_{1/2}$  decreases with the increase of temperature.

$$t_{99.6} = \frac{2.303}{K} \log \left( \frac{100}{0.4} \right)$$

$$t_{99.6} = \frac{2.303}{K} (2.4) = 8 \times \frac{0.693}{K} = 8t_{1/2}$$

7. (a, b) The reaction can occur by following two ways.

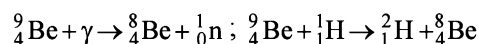

8. (b, c, d)

(A) High activation energy usually implies a **slow reaction**.

(B) Rate constant of a reaction increases with increase in temperature due to increase in number of collisions whose energy exceeds the activation energy.

$$(C) \quad k = P \times Z \times e^{-E_a/RT}$$

(D) So, pre-exponential factor ( $A$ ) =  $P \times Z$  and it is independent of activation energy or energy of molecules.

9. (b, d) When N/P ratio is less than one, then proton changes into neutron.

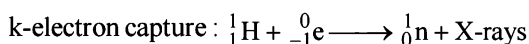
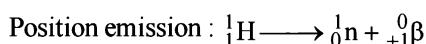

#### E. Subjective Problems

1. From data (i) and (ii) it is obvious that when the concentration of B is kept constant ( $0.01 \text{ mol litre}^{-1}$ ) and the concentration of A is doubled ( $0.01$  to  $0.02 \text{ mol litre}^{-1}$ ), the rate of reaction is also doubled ( $0.005$  to  $0.010 \text{ mol litre}^{-1} \text{ min}^{-1}$ ). This shows that the rate of reaction varies directly as the first power of the concentration. Hence **the order of reaction with respect to A is 1**.

Similarly, from data (i) and (iii) it is obvious that when the concentration of A is kept constant ( $0.01 \text{ mol litre}^{-1}$ ) and the concentration of B doubled ( $0.01$  to  $0.02 \text{ mol litre}^{-1}$ ), the rate of reaction remains constant ( $0.005 \text{ mol litre}^{-1} \text{ min}^{-1}$ ). This shows that the **order of reaction with respect to B is zero**. Now we know that the rate of reaction,  $A + B \rightarrow \text{Products}$ , is given by

$$\text{Rate } r = k [A]^1 [B]^0 \Rightarrow r = k [A]$$



$$\therefore k = \frac{r}{[A]} = \frac{0.005}{0.01} = 0.5 \text{ min}^{-1}$$

$$[\because r = 0.005 \text{ mol/l/m and } [A] = 0.01 \text{ mol/l}]$$

$$\text{We know that } t_{1/2} = \frac{0.693}{k} = \frac{0.693}{0.5} \quad [\because k = 0.5 \text{ min}^{-1}]$$

$$= 1.386 \text{ minutes}$$

## 2. TIPS/Formulae :

$$N = N_0 \left(\frac{1}{2}\right)^n$$

Half life,  $t_{1/2} = 5770$  years

Let the original sample be 1 gram.

$\therefore$  After every 5770 years one-half of radioactive carbon would decay or disintegrate.

Thus, 1 g sample becomes  $\frac{1}{2}$  g after 5770 years and

$$\frac{1}{2} \times \frac{1}{2} = \frac{1}{4} \text{ left after 11,540 years.}$$

$\therefore$  25% of radioactive carbon remains after 11540 years.

Rate constant,  $k$  for first order reaction,

$$k = \frac{0.693}{t_{1/2}} = \frac{0.693}{5770} = 1.2 \times 10^{-4} \text{ year}^{-1}.$$

## 3. Assuming that the decomposition of $\text{N}_2\text{O}_5$ is a first order reaction, then

$$k = \frac{2.303}{t} \log \frac{a}{(a-x)} = \frac{2.303}{t} \log \frac{P_0}{P}$$

$$\text{or } \log P = \frac{-kt}{2.303} + \log P_0$$

Thus  $\log P$  vs time graph is linear with slope =  $\frac{-k}{2.303}$  if the

given reaction is of first order which is in accordance with the given statement. Thus the reaction obeys first order reaction.

## 4. ${}_{90}^{234}\text{Th} \rightarrow {}_{82}^{206}\text{Pb}$

**NOTE :** For emission of one  $\alpha$ -particle, atomic mass decreases by 4 and atomic number by 2. Further for the emission of one  $\beta$ -particle, the atomic mass does not change but the atomic number increases by 1.

So we first find the  $\alpha$ -particles :

$$\text{Decrease in atomic mass} = 234 - 206 = 28$$

$$\text{No. of } \alpha\text{-particles emitted} = \frac{28}{4} = 7$$

Hence, atomic number should have decrease to  $90 - (7 \times 2) = 76$

Now, atomic number of Pb = 82, which is more by  $(82 - 76) = 6$

This increase is due to ionisation of  $\beta$ -particles.

Therefore,  $\beta$ -particles emitted = 6

## 5. TIPS/Formulae :

For a first order reaction we know that

$$k = \frac{2.303}{t} \log \frac{a}{(a-x)}$$

Here,  $t = 10 \times 60 \times 60$  sec. and let  $a = 1$ , then substituting the values, we get

$$1.5 \times 10^{-6} = \frac{2.303}{10 \times 3600} \log \frac{1}{(1-x)}$$

$$\frac{1.5 \times 10^{-6} \times 10 \times 3600}{2.303} = \log \frac{1}{(1-x)}$$

$$0.0234 = \log \frac{1}{(1-x)}$$

$$\text{Taking antilog, } 1.055 = \frac{1}{(1-x)}$$

$$\text{or } 1.055 - 1.055x = 1 \Rightarrow x = \frac{(1.055 - 1)}{1.055} = 0.052$$

Thus, 5.2% of the initial concentration has changed into product.

Again we know that

$$t_{1/2} = \frac{0.693}{k} = \frac{0.693}{1.5 \times 10^{-6}} = 462000 \text{ second} = 128.33 \text{ hours}$$

## 6. TIPS/Formulae :

$$k = \frac{0.693}{t_{1/2}}; \quad \frac{k_1}{k_2} = \frac{E_a}{2.303R} \left[ \frac{T_2 - T_1}{T_1 T_2} \right]$$

Substituting the value at the two given conditions

$$k_{27^\circ} = \frac{0.693}{30} = 0.0231 \text{ min}^{-1}; \quad k_{47^\circ} = \frac{0.693}{10} = 0.0693 \text{ min}^{-1}$$

$$\text{We also know that } \log \frac{k_{47}}{k_{27}} = \frac{E_a}{2.303R} \times \frac{T_2 - T_1}{T_1 \times T_2}$$

$$\text{or } E_a = \frac{2.303R \times T_1 \times T_2}{T_2 - T_1} \log \frac{k_{47}}{k_{27}}$$

$$= \frac{2.303 \times 8.314 \times 10^{-3} \times 300 \times 320}{320 - 300} \times \log \frac{0.0693}{0.0231}$$

$$= 43.848 \text{ kJ mol}^{-1}$$

## 7. Minimum number of $\beta$ -particles required in one minute = 346

No. of  $\beta$ -particles required for carrying out the experiment for  $6.909 \times 60$  minutes =  $346 \times 6.909 \times 60 = 143431$

$\therefore$  Amount of  $\beta$ -particles required

$$= \frac{143431}{6.023 \times 10^{23}} = 2.3814 \times 10^{-19} \text{ mol}$$

$$\text{Now we know that, } \lambda = \frac{0.693}{t_{1/2}} = \frac{0.693}{66.6} = 0.0104 \text{ hr}^{-1}$$

$$\text{Further we know that, } \lambda = \frac{2.303}{t} \log \frac{a}{a-x}$$

where  $a$  = Initial concentration of  $\beta$ -particles

$x$  = Consumed concentration of  $\beta$ -particles

$$\log \frac{a-x}{a} = -\frac{\lambda t}{2.303} = -\frac{0.0104 \times 6.909}{2.303} = -0.0312$$

$$= \bar{1}.9688$$

$$\text{or } \frac{a-x}{a} = 0.931 \quad [\text{Taking antilog}]$$

$$\text{or } \frac{a - 2.3814 \times 10^{-19}}{a} = 0.931 \quad [\because x = 2.3814 \times 10^{-19}]$$

On usual calculations,  $a = 3.451 \times 10^{-18} \text{ mol}$

### 8. TIPS/Formulae :

According to Arrhenius equation

$$\log k = \log A - \frac{E_a}{2.303 RT}$$

$$\text{We know that } k = \frac{0.693}{t_{1/2}} = \frac{0.693}{10 \times 60} \quad (t_{1/2} = 10 \times 60 \text{ sec.})$$

$$= 1.155 \times 10^{-3}$$

Substituting the various values in the above equation, we get

$$\log 1.155 \times 10^{-3} = \log 4 \times 10^{13} - \frac{98.6}{2.303 \times 8.314 \times 10^{-3} \times T}$$

On usual calculations,  $T = 311.35 \text{ K}$

### 9. $2\text{N}_2\text{O}_5(\text{g}) \rightarrow 4\text{NO}_2(\text{g}) + \text{O}_2(\text{g})$

2 mol of gaseous nitrogen pentoxide on complete decomposition gives 5 mol of gaseous products.

$$\text{Therefore, initial pressure of } \text{N}_2\text{O}_5 = 584.5 \times \frac{2}{5}$$

$$= 233.8 \text{ mm Hg.}$$

Let  $x$  be the amount of  $\text{N}_2\text{O}_5$  decomposed after 30 min.

$\therefore$  After 30 min.

Pressure due to  $\text{N}_2\text{O}_5 = 233.8 - x$ ; Pressure due to  $\text{NO}_2 = 2x$

$$\text{and pressure due to } \text{O}_2 = \frac{x}{2}$$

Total pressure after 30 min

$$= 284.5 \text{ mm Hg} = 233.8 - x + 2x + \frac{x}{2}$$

$$\text{or } 233.8 + \frac{3x}{2} = 284.5 \quad \text{or } x = 33.8 \text{ mm Hg}$$

Hence pressure of  $\text{N}_2\text{O}_5$  after 30 min.

$$= 233.8 - 33.8 = 200 \text{ mm Hg}$$

$$k = \frac{2.303}{t} \log \frac{a}{(a-x)} = \frac{2.303}{30} \log \frac{233.8}{200}$$

$$k = \frac{2.303}{30} \times 0.0679 = 5.2 \times 10^{-3} \text{ min}^{-1}$$

10.  $A \rightarrow \text{Products}$  ... (i)

$B \rightarrow \text{Product}$  ... (ii)

Half-life of (i) reaction at 310  $k = 30 \text{ min.}$

$$\therefore {}_A k_{310} = \frac{0.693}{30} \text{ min}^{-1} \quad \dots (1)$$

$$\text{Also given, } \frac{{}_A k_{310}}{{}_A k_{300}} = 2 \quad \dots (2)$$

$$\text{Also at 310 } k, {}_B k_{310} = 2 {}_A k_{310} \quad \dots (3)$$

$$\text{Also } E_B = \frac{1}{2} E_A$$

According to Arrhenius equation,  $k = A e^{-E/RT}$  ... (4)

$$\text{or } \log \frac{k_2}{k_1} = \frac{E}{2.303 R} \left[ \frac{T_2 - T_1}{T_1 T_2} \right]$$

For reaction (i),

$$\log \frac{{}_A k_{310}}{{}_A k_{300}} = \frac{E_A}{2.303 R} \left[ \frac{10}{300 \times 310} \right] \quad \dots (5)$$

For reaction (ii),

$$\log \frac{{}_B k_{310}}{{}_B k_{300}} = \frac{E_B}{2.303 R} \left[ \frac{10}{300 \times 310} \right] \quad \dots (6)$$

Dividing (6) by (5),

$$\frac{\log \frac{{}_B k_{310}}{{}_B k_{300}}}{\log \frac{{}_A k_{310}}{{}_A k_{300}}} = \frac{E_B}{E_A} = \frac{1}{2} \quad \left( \because E_B = \frac{1}{2} E_A \right)$$

$$\text{or } \log \frac{{}_A k_{310}}{{}_A k_{300}} = 2 \log \frac{{}_B k_{310}}{{}_B k_{300}} = \log \left( \frac{{}_B k_{310}}{{}_B k_{300}} \right)^2$$

$$\text{or } \frac{{}_A k_{310}}{{}_A k_{300}} = \left( \frac{{}_B k_{310}}{{}_B k_{300}} \right)^2 \quad \dots (7)$$

Combining (7), (2) and (3), we get

$$\left( \frac{2 {}_A k_{310}}{{}_B k_{300}} \right)^2 = 2$$

$$2 {}_A k_{310} = \sqrt{2} \times {}_B k_{300}; \quad {}_B k_{300} = \sqrt{2} \times {}_A k_{310}$$

$${}_B k_{300} = 1.414 \times \frac{0.693}{30} = 3.267 \times 10^{-2} \text{ min}^{-1}$$

11. The ratio of  $\text{H}^3 : \text{H}^1 :: 8 \times 10^{-18} : 1$   
 $\therefore$  No. of H atoms in 18 g  $\text{H}_2\text{O} = 2N$   
 $\therefore$  No. of  $\text{H}^3$  atoms in 18 g of  $\text{H}_2\text{O}$   
 $= 2N \times 8 \times 10^{-18} = 2 \times 6.023 \times 10^{23} \times 8 \times 10^{-18}$  atoms  
 $\therefore$  No. of  $\text{H}^3$  atoms in 10 g  $\text{H}_2\text{O}$

$$= \frac{2 \times 6.023 \times 10^{23} \times 8 \times 10^{-18} \times 10}{18} \text{ atoms}$$

$$= 5.354 \times 10^6 \text{ atoms}$$

No. of atoms left after 40 years are derived as follows using the relation

$$t = \frac{2.303}{\lambda} \log \frac{N_0}{N}$$

$$40 = \frac{2.303 \times 12.3}{0.693} \log \frac{5.354 \times 10^6}{N} \therefore N = 5.624 \times 10^5 \text{ atoms}$$

## 12. TIPS/Formulae :

According to Arrhenius equation

$$\log \frac{k_2}{k_1} = \frac{E_a}{2.303 R} \left( \frac{1}{T_1} - \frac{1}{T_2} \right)$$

Calculation of  $k$  at  $25^\circ\text{C}$  (298 K), i.e.  $k_1$

Here  $a = 100$ ,  $a - x = 100 - 25$ ,  $t = 20$  mts.

$$\text{Thus } k_1 = \frac{2.303}{20} \log \frac{100}{75} = 0.014386 \text{ min}^{-1}$$

Calculation of  $k$  at  $40^\circ\text{C}$  (313 K) i.e.,  $k_2$

Substituting various values, we get

$$\begin{aligned} \log \frac{k_2}{0.014386} &= \frac{70 \times 10^3}{2.303 \times 8.314} \times \left( \frac{1}{298} - \frac{1}{313} \right) \\ &= \frac{70 \times 10^3 \times 15}{2.303 \times 8.314 \times 298 \times 313} = 0.587 \end{aligned}$$

$$\log k_2 = 0.014386 \times 0.587; k_2 = 0.05570 \text{ min}^{-1}$$

Calculation of % decomposition at  $40^\circ\text{C}$

Thus here  $a = 100$ ,  $a - x = 100 - x$ ,  $t = 20$  mts.,  $k_2 = 0.05570$

Substituting the values in the first order reaction equation :

$$k_2 = 0.05570 = \frac{2.303}{20} \log \frac{100}{100 - x}$$

On usual calculations,  $x = 67.169 = 67.17\%$

13.  $\text{CH}_3 - \text{O} - \text{CH}_3(\text{g}) \rightarrow \text{CH}_4(\text{g}) + \text{CO}(\text{g}) + \text{H}_2(\text{g})$

Given  $t_{1/2} = 14.5$  min, initial pressure = 0.40 atm,  $t = 12$  min.

$$\text{Now, } k = \frac{0.693}{14.5} = 4.78 \times 10^{-2} \text{ min}^{-1}$$

Writing first order equation and substituting the given values, we get

$$4.78 \times 10^{-2} = \frac{2.303}{12 \text{ min.}} \log \frac{0.4}{0.4 - x}$$

which gives  $x = 0.175$  atm

Since volume and temp. are constant, final pressure :

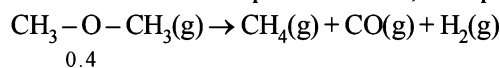

$$\begin{array}{ccccccc} & & 0.4 & & & & \\ & & 0.4 - 0.175 & & 0.175 & & 0.175 & & 0.175 \end{array}$$

Hence total pressure =  $0.4 - 0.175 + 3 \times 0.175 = 0.749$  atm

14. (i) According to Fig. in the given time of 4 hours (1 to 5) concentration of  $A$  falls from 0.5 to 0.3 M, while in the same time concentration of  $B$  increases from 0.2 M to 0.6 M.

Decrease in concentration of  $A$  in 4 hours

$$= 0.5 - 0.3 = 0.2 \text{ M}$$

Increase in concentration of  $B$  in 4 hours

$$= 0.6 - 0.2 = 0.4 \text{ M}$$

Thus increase in concentration of  $B$  in a given time is twice the decrease in concentration of  $A$ . Thus  $n = 2$ .

$$(ii) K = \frac{[B^2]_{\text{eq.}}}{[A]_{\text{eq.}}} = \frac{(0.6)^2}{0.3} = 1.2 \text{ M}$$

- (iii) Initial rate of conversion of  $A$

= Change in conc. of  $A$  during 1 hour

$$= \frac{0.6 - 0.5}{1} = 0.1 \text{ mole litre}^{-1} \text{ hour}^{-1}$$

15. Let the order with respect to  $A$  is  $x$  and the order with respect to  $B$  is  $y$

Then, Rate =  $k[A]^x[B]^y$

$$5.0 \times 10^{-4} = k[2.5 \times 10^{-4}]^x [3.0 \times 10^{-5}]^y \dots (i)$$

$$4.0 \times 10^{-3} = k[5.0 \times 10^{-4}]^x [6.0 \times 10^{-5}]^y \dots (ii)$$

$$1.6 \times 10^{-2} = k[1.0 \times 10^{-3}]^x [6.0 \times 10^{-5}]^y \dots (iii)$$

From (ii) and (iii), we get  $2^x = 4$ ;  $x = 2$

From (i) and (ii), we get  $2^{x+y} = 8$ ;  $x + y = 3$ ;  $y = 1$

$\therefore$  The rate equation for the reaction is

$$\text{Rate} = k[A]^2[B]$$

- (i) Thus **order of reaction with respect to  $A = 2$  and order of reaction with respect to  $B = 1$ .**

- (ii) Rate constant ( $k_1$ ) at 300 K

$$\begin{aligned} k_1 &= \frac{\text{Rate}}{[A]^2[B]} \\ &= \frac{5.0 \times 10^{-4} \text{ mol l}^{-1} \text{ s}^{-1}}{(2.5 \times 10^{-4} \text{ mol l}^{-1})^2 (3.0 \times 10^{-5} \text{ mol l}^{-1})} \\ &= 2.66 \times 10^8 \text{ mol}^{-2} \text{ l}^2 \text{ s}^{-1} \end{aligned}$$

- (iii) Determination of energy of activation :

Rate constant ( $k_2$ ) at 320 K

$$\begin{aligned} k_2 &= \frac{\text{Rate}}{[A]^2[B]} \\ k_2 &= \frac{2.0 \times 10^{-3} \text{ mol l}^{-1} \text{ s}^{-1}}{(2.5 \times 10^{-4} \text{ mol l}^{-1})^2 (3.0 \times 10^{-5} \text{ mol l}^{-1})} \\ &= 1.066 \times 10^9 \text{ mol}^{-2} \text{ l}^2 \text{ s}^{-1} \end{aligned}$$

$$\log \frac{k_2}{k_1} = \frac{E_a}{2.303 R} \left[ \frac{T_2 - T_1}{T_1 T_2} \right]$$

$$\text{or } E_a = 2.303 R \left[ \log \frac{k_2}{k_1} \right] \left[ \frac{T_1 T_2}{T_2 - T_1} \right]$$

$$= 2.303 \times 8.314 \left[ \log \frac{1.066 \times 10^9}{2.66 \times 10^8} \right] \left[ \frac{320 \times 300}{20} \right]$$

$$= 5.54 \times 10^4 \text{ J}$$

(iv) Determination of the pre-exponential factor

$$\log k = -\frac{E_a}{2.303 R} \times \frac{1}{T} + \log A$$

$$\log 2.66 \times 10^8 = \frac{5.54 \times 10^4}{2.303 \times 8.314} \times \frac{1}{300} + \log A$$

$$\text{or } 8.425 + 9.645 = \log A; \log A = 18.07$$

$$\therefore A = 1.175 \times 10^{18} \text{ l}^2 \text{ mol}^{-2} \text{ sec}$$

16. Wt. of  $^{90}\text{Sr}$  at start,  $N_0 = 1\text{mg}$ , Wt. of  $^{90}\text{Sr}$  after 20 years,  $N_t = ?$ , Time  $t = 20$  years  
Half-life of  $^{90}\text{Sr}$ ,  $T_{1/2} = 28.1$  years  
Calculation of decay constant,

$$\lambda = \frac{0.693}{T_{1/2}} = \frac{0.693}{28.1} = 0.0247 \text{ years}^{-1}$$

Substituting the values in the relation  
 $N_t = N_0 e^{-\lambda t} = 1 e^{-0.0247 \times 20} = 0.061 \mu\text{g}$

17.  $k_{653\text{K}} = \frac{0.693}{360} = 1.925 \times 10^{-3} \text{ min}^{-1}$

Calculation of  $k_{723\text{K}}$   
 $E_a = 200 \text{ kJ mol}^{-1} = 200 \times 10^3 \text{ J mol}^{-1}$   
 $T_2 = 723 \text{ K}$ ,  $T_1 = 653 \text{ K}$   
 $k_{653\text{K}} = 1.925 \times 10^{-3} \text{ min}^{-1}$

We know that,  $\frac{k_2}{k_1} = e^{-\frac{E_a}{R} \left( \frac{1}{T_2} - \frac{1}{T_1} \right)}$

$$\text{or } \frac{k_{723\text{K}}}{1.925 \times 10^{-3}} = e^{-\frac{200 \times 10^3}{8.314} \left[ \frac{1}{723} - \frac{1}{653} \right]}$$

On usual calculations,  $k_{723\text{K}} = 6.81 \times 10^{-2} \text{ min}^{-1}$   
Calculation of time for 75% decomposition at 723 K  
Let the initial amount of  $\text{H}_2\text{O}_2$ ,  $a = 1$   
 $\therefore$  Amount at the required time,  $(a-x) = 0.25$   
Substituting the values in the given relation,

$$t = \frac{2.303}{k_{723\text{K}}} \log \frac{a}{a-x} = \frac{2.303}{6.81 \times 10^{-2}} \log \frac{1}{0.25} = 20.34 \text{ min}$$

18.  $\lambda_{\text{Ac}} = \frac{0.693}{21.8} = 3.18 \times 10^{-2} \text{ year}^{-1}$

Since the decay involves two parallel paths

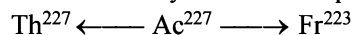

$$\lambda_{\text{Ac}} = \lambda_{\text{Th}} + \lambda_{\text{Fr}}$$

Thus, Fractional yield of Th =  $\frac{\lambda_{\text{Th}}}{\lambda_{\text{Ac}}}$

$$\text{or } \lambda_{\text{Th}} = 3.18 \times 10^{-2} \times \frac{1.2}{100} = 3.81 \times 10^{-4} \text{ yr}^{-1}$$

Similarly, Fractional yield of Fr =  $\frac{\lambda_{\text{Fr}}}{\lambda_{\text{Ac}}}$

$$\therefore \lambda_{\text{Fr}} = 3.18 \times 10^{-2} \times \frac{98.8}{100} = 3.14 \times 10^{-2} \text{ yr}^{-1}$$

19.  $\text{NH}_3 + \text{H}_2\text{O} \xrightleftharpoons[K_b]{K_f} \text{NH}_4^+ + \text{OH}^-; K_b = 3.4 \times 10^{10}$



$$K_{\text{base}} = \frac{K_f}{K_b} = \frac{K_w}{K_{\text{acid}}} \text{ or } \frac{K_f}{3.4 \times 10^{10}} = \frac{10^{-14}}{5.6 \times 10^{-10}}$$

$$\therefore K_f = 6.07 \times 10^5$$

20. (i) The Arrhenius equation is

$$k = A \exp(-E_a/RT)$$

Taking natural logarithm, we get

$$\ln k = \ln A - E_a/RT$$

$$\text{Thus } \log k = \log A - \frac{E_a}{2.303 R} \cdot \frac{1}{T}$$

Comparing this expression with the given one, we get

$$\frac{E_a}{2.303 R} = 1.25 \times 10^4 \text{ K}$$

$$\text{Hence, } E_a = (1.25 \times 10^4 \text{ K})(2.303)(8.314 \text{ JK}^{-1} \text{ mol}^{-1})$$

$$= 2.39 \times 10^5 \text{ J mol}^{-1} = 239 \text{ kJ mol}^{-1}$$

- (ii) The reaction is first order as the unit of rate constant is  $\text{s}^{-1}$ . For a first order reaction,

$$t_{1/2} = \frac{0.693}{k}$$

$$\text{Hence, } k = \frac{0.693}{256 \times 60 \text{ s}} = 4.51 \times 10^{-5} \text{ s}^{-1}$$

Substituting this in the given expression, we get

$$\log (4.51 \times 10^{-5}) = 14.34 - \frac{1.25 \times 10^{-5} \text{ K}}{T}$$

$$\text{or } -4.346 = 14.34 - \frac{1.25 \times 10^{-4} \text{ K}}{T}$$

$$\text{or } T = \frac{1.25 \times 10^{-4} \text{ K}}{18.686} = 669 \text{ K}$$

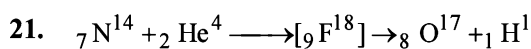

22. 
$$\log \frac{k_2}{k_1} = \frac{E_a}{2.303 \times R} \left[ \frac{T_2 - T_1}{T_1 T_2} \right]$$

$$\therefore \log \frac{4.5 \times 10^7}{1.5 \times 10^7} = \frac{E_a}{8.314 \times 2.303} \left[ \frac{373 - 323}{373 \times 323} \right]$$

$$\therefore E_a = 2.2 \times 10^4 \text{ J mol}^{-1}$$

Now  $k = Ae^{-E_a/RT}$

$$\therefore 4.5 \times 10^7 \text{ J mol}^{-1} = Ae^{-\frac{2.2 \times 10^4}{8.314 \times 373}} \therefore A = 5.42 \times 10^{10} \text{ sec}^{-1}$$

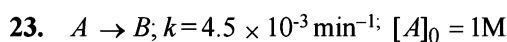

For first order reaction,  $k = \frac{2.303}{t} \log \frac{a}{(a-x)}$

 Find  $(a-x)$  at  $t = 60$  min.

$$4.5 \times 10^{-3} = \frac{2.303}{60} \log \frac{1}{(a-x)} \therefore (a-x) = 0.7634$$

$$\text{Thus rate after 60 minute} = k(a-x) = 4.5 \times 10^{-3} \times 0.7634 = 3.4354 \times 10^{-3} \text{ M min}^{-1}$$

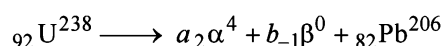
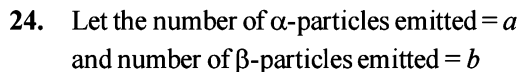

Thus  $4a + 206 = 238$ ; Therefore  $a = 8$

Further  $2a - b + 82 = 92$ ; Therefore  $b = 6$

 Composition of the ore indicates that it has 1 gm of U and 0.1 gm of Pb; thus here  $N_t = 1$  gm

 Determination of  $N_0$ 

206 g Pb is obtained from 238 g of U

$$0.1 \text{ g Pb is obtained from} = \frac{238}{206} \times 0.1 \text{ g} = 0.1155 \text{ g}$$

Therefore initial amount of U ( $N_0$ ) =  $1 + 0.1155 = 1.1155$

Now we know that

$$t = \frac{2.303}{k} \log \frac{N_0}{N_t} = \frac{2.303}{0.693/4.5 \times 10^9} \log \frac{1.1155}{1}$$

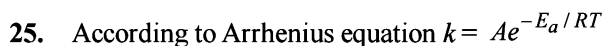
 By usual calculations,  $t = 7.097 \times 10^8$  years.

 Let  $E_a$  of the reaction in absence of catalyst =  $x \text{ kJ mol}^{-1}$ 

 Therefore  $E_a$  of the reaction in presence of catalyst =  $x - 20 \text{ kJ mol}^{-1}$ 

The Arrhenius equations in the two conditions can thus be written as

$$k = Ae^{-\frac{x}{R \times 500}} \dots (i)$$

$$k = Ae^{-\frac{x-20}{R \times 400}} \dots (ii)$$

Dividing equation (i) by (ii), we get

$$e^{-\frac{x}{500R}} = e^{-\frac{x-20}{400R}} \Rightarrow \frac{x}{500} = \frac{x-20}{400} \text{ or } x = 100 \text{ kJ mol}^{-1}$$

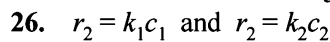

Since rate of first order reaction is directly proportional to the concentration of its reactant,

$$\therefore \frac{r_1}{r_2} = \frac{c_1}{c_2} = \frac{0.04}{0.03}$$

According to first order reaction

$$k = \frac{2.303}{t_{20} - t_{10}} \log \frac{c_1}{c_2}$$

On substituting the various values

$$k = 0.0287 \text{ min}^{-1}$$

$$t_{1/2} = \frac{0.693}{k} = \frac{0.693}{0.0287} = 24.14 \text{ min}$$

 Total number of moles after 100 min =  $x + 12 + 0.525$ 

$$P_{\text{mix}} = P_A + P_B$$

$$= \left( \frac{x}{12+x} \times 300 \right) + \left( \frac{12}{12+x} \times 500 \right) = \frac{6000 + 300x}{12+x}$$

According to Raoult's law

$$\frac{\left( \frac{6000 + 300x}{12+x} \right) - 400}{6000 + 300x} = \frac{0.525}{x + 12 + 0.525}$$

 On solving we get,  $x = 9.9$ 

Now according to first order kinetics,

$$k = \frac{2.303}{100} \log \frac{10}{9.9} = 1.005 \times 10^{-4} \text{ min}^{-1}$$

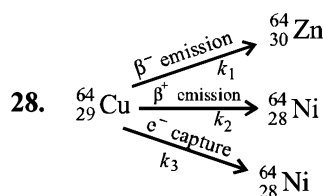
 Let the rate constants of the above emission processes be  $k_1$ ,  $k_2$  and  $k_3$  respectively and the overall rate constant be  $k$ . Then

$$k = k_1 + k_2 + k_3 = \frac{0.693}{t_{1/2}} = \frac{0.693}{12.8} \text{ h}^{-1}$$

$$\text{Also, } k_1 = 0.38 k = 0.38 \times \frac{0.693}{12.8} \text{ h}^{-1}$$

$$t_1 = \frac{0.693 \times 12.8}{0.38 \times 0.693} = 33.68 \text{ h}$$

Similarly,

$$t_2 = \frac{0.693}{k_2} = \frac{0.693}{0.19k} = \frac{0.693}{0.19 \times 0.693} \times 12.8 = \mathbf{67.36h},$$

$$t_3 = \frac{0.693}{k_3} = \frac{0.693}{0.43k} = \frac{12.8}{0.43} = \mathbf{29.76h}$$

where  $t_1$ ,  $t_2$  and  $t_3$  are the partial half-lives for  $\beta^-$  emission,  $\beta^+$  emission and electron capture processes, respectively.

29. (a) From the rate law expression,  $R_0 = k[A_0]^a[B_0]^b$  and from the table it is clear that :
- when the concentration of  $[A_0]$  is doubled, keeping  $[B_0]$  constant (see readings 1 and 2), the rate also doubles i.e. rate is directly proportional to  $[A_0]$  or  $a=1$ .
  - when the concentration of  $[B_0]$  is reduced, keeping  $[A_0]$  constant (see readings 1 and 3), the rate remains constant. i.e. rate is independent of  $[B_0]$  or  $b=0$

Thus, rate equation becomes  $R_0 = k[A_0]$

(b)  $k = \frac{R_0}{[A_0]} = \frac{0.05}{0.10} = \mathbf{0.5 \text{ sec}^{-1}}$

### 30. TIPS/Formulae :

- Sum of atomic masses of reactant = sum of atomic masses of products
- Sum of atomic numbers of reactant = sum of atomic numbers of products
- The atomic number of the final stable product =  $90 - 7 \times 2 + 1 \times 6 = 82$  & the mass number of the final stable product =  $234 - 7 \times 4 + 0 = 206$ . Thus the element  $X$  should be  ${}_{82}\text{Pb}^{206}$ .

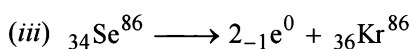
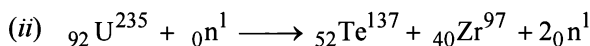

31. (i) From the given data, it is evident that the  $t_{1/2}$  (half-life period) for the decomposition of  $X(g)$  is constant (100 minutes) therefore the order of reaction is **one**.

(ii) Rate constant,  $k = \frac{0.693}{t_{1/2}}$

$$= \frac{0.693}{100} = \mathbf{6.93 \times 10^{-3} \text{ min}^{-1}}$$

- (iii) Time taken for 75% completion of reaction =  $2 t_{1/2} = 2 \times 100 = 200$  minutes

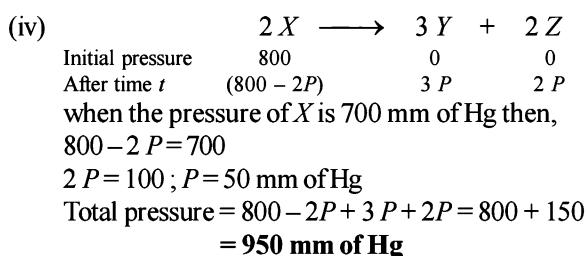

## G. Comprehension Based Questions

- (c) It is clear from the 3rd paragraph, which states that in living organisms a dynamic equilibrium is established whereby the ratio of  $\text{C}^{14}$  to  $\text{C}^{12}$  remains constant. The  $\text{C}^{14}$  which decays into  $\text{N}^{14}$  is replenished by the production of new isotopes.
- (b) As the half-life of  $\text{C}^{14}$  is 5760 years, so a 6 year old fossil's age can't be determined. Further this technique cannot be used to date objects older than 30,000 years. After this length of time the radioactivity is too low to be measured.

3. (a)  $T_1 = \frac{1}{\lambda} \ln C_1, T_2 = \frac{1}{\lambda} \ln C_2$

Let the concentration of  $\text{C}^{14}$  in the fossil be  $C$ . In nearby areas concentration of  $\text{C}^{14}$  in living beings will be  $C_1$  and in far off places  $C_2$ , obviously  $C_1 > C_2$ . Hence, age of fossil in nearby areas,

$$T_1 = \frac{1}{\lambda} \ln \frac{C_1}{C} \quad \dots\dots (i)$$

And age in far off places,  $T_2 = \frac{1}{\lambda} \ln \frac{C_2}{C} \quad \dots\dots (ii)$

From (i) and (ii),  $T_1 - T_2 = \frac{1}{\lambda} \ln \frac{C_1}{C_2}$

Since,  $C_1 > C_2$ , R.H.S. is positive i.e.,  $T_1 > T_2$ .

## H. Assertion & Reason Type Questions

- (a) Assertion is correct as for every  $10^\circ\text{C}$  raise in temperature, the specific rate constant,  $K$  nearly doubles. (Although it is not correct for all reactions. For some reactions  $K$  even gets tripled for  $10^\circ\text{C}$  raise). [NOTE : The value of temperature coefficient is the ratio of rate constants at two different temperature (which differ by  $10^\circ\text{C}$ ) generally lies between 2 and 3] The statement is clearly true and it explains the assertion, as the rate of collision among the molecules doubles for  $10^\circ$  rise in temperature.

### I. Integer Value Correct Type

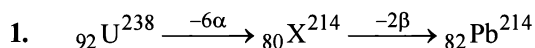

Hence total number of particles emitted are  $2 + 6 = 8$

2. The integrated form of a zero-order reaction is  $[A_0] - [A_t] = k_0 t$ ;  $1.0 - 0.75 = k_0 \times 0.05$ ,  $k_0 = 5$   
 Again,  $1.0 - 0.4 = k_0 \times 0.12$ ,  $k_0 = 5$

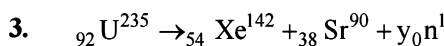

$$235 = 142 + 90 + y \Rightarrow y = 3.$$

The number of neutrons emitted are 3.

4. 9

$$t_{1/8} = \frac{2.303 \log 8}{k} = \frac{2.303 \times 3 \log 2}{k}$$

$$t_{1/10} = \frac{2.303}{k} \log 10 = \frac{2.303}{k}$$

$$\left[ \frac{t_{1/8}}{t_{1/10}} \right] \times 10 = \frac{\left( \frac{2.303 \times 3 \log 2}{k} \right)}{\left( \frac{2.303}{k} \right)} \times 10 = 9$$

5. 8

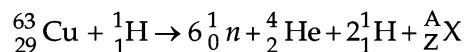

Balancing the atomic mass and atomic number

$$63 + 1 = (6 \times 1) + 4 + 2 + A \Rightarrow A = 52$$

$$29 + 1 = (6 \times 0) + 2 + 2 + Z \Rightarrow Z = 26$$

$$\text{Thus } \frac{A}{Z}X = \frac{52}{26}X \text{ or } \frac{52}{26}\text{Fe}$$

Hence, X belongs to group 8 in the periodic table.

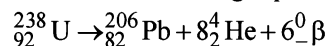
6. (9) Number of moles in gas phase, at start ( $n_i$ ) = 1Now number of moles in gas phase, after decomposition ( $n_F$ )

$$= 1 + 8 = 9 \text{ mole}$$

at constant temperature and pressure

$$\frac{P_F}{P_{in}} = \frac{n_F}{n_{in}} = \frac{9}{1} = 9$$

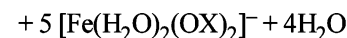
7. (8)  $8\text{H}^+ + 5[\text{Fe}(\text{H}_2\text{O})_2(\text{OX})_2]^{2-} + \text{MnO}_4^- \rightarrow \text{Mn}^{2+} +$ 

$$\text{Rate} = \frac{1}{8} \frac{d[\text{H}^+]}{dt} = -\frac{d[\text{MnO}_4^-]}{dt}$$

$$\text{Hence, } \frac{\text{rate of } [\text{H}^+] \text{ decay}}{\text{rate of } [\text{MnO}_4^-] \text{ decay}} = 8$$

## Section-B JEE Main/ AIEEE

1. (a) For a zero order reaction.

$$\text{rate} = k[A]^0 \text{ i.e. rate} = k$$

$$\text{hence unit of } k = \text{M} \cdot \text{sec}^{-1}$$

For a first order reaction.

$$\text{rate} = k[A]$$

$$k = \text{M} \cdot \text{sec}^{-1} / \text{M} = \text{sec}^{-1}$$

2. (a) NOTE : Order is the sum of the power of the concentrations terms in rate law expression.

Hence the order of reaction is = 1 + 2 = 3

3. (d) rate of appearance of HI =  $\frac{1}{2} \frac{d[\text{HI}]}{dt}$ 

$$\text{rate of formation of } \text{H}_2 = \frac{-d[\text{H}_2]}{dt}$$

$$\text{rate of formation of } \text{I}_2 = \frac{-d[\text{I}_2]}{dt}$$

$$\text{hence } \frac{-d[\text{H}_2]}{dt} = -\frac{d[\text{I}_2]}{dt} = \frac{1}{2} \frac{d[\text{HI}]}{dt}$$

$$\text{or } -\frac{2d[\text{H}_2]}{dt} = -\frac{2d[\text{I}_2]}{dt} = \frac{d[\text{HI}]}{dt}$$

4. (d)  $t_{1/2} = 5$  years,  $T = 15$  years hence total number of half

$$\text{life periods} = \frac{15}{5} = 3.$$

$$\therefore \text{Amount left} = \frac{64}{(2)^3} = 8\text{g}$$

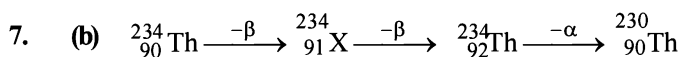
5. (a)  $Rt = \log C_o - \log C_t$ It is clear from the equation that if we plot a graph between  $\log C_t$  and time, a straight line with a slopeequal to  $-\frac{k}{2.303}$  and intercept equal to  $\log [A_o]$  will be obtained.6. (c)  ${}_0n^1 \rightarrow {}_{+1}p^1 + {}_{-1}e^0$ 8. (d)  $t_{1/2} = 3$  hrs.  $T = 18$  hours  $\therefore T = n \times t_{1/2}$ 

$$\therefore n = \frac{18}{3} = 6$$

Initial mass ( $C_o$ ) = 256 g

$$\therefore C_n = \frac{C_o}{2^n} = \frac{256}{(2)^6} = \frac{256}{64} = 4\text{g}$$

9. (b) In equation  $K = Ae^{-E_a/RT}$ ;  $A$  = Frequency factor  
 $K$  = velocity constant,  $R$  = gas constant and  $E_a$  = energy of activation10. (c)  $\text{Rate}_1 = k[A]^n[B]^m$ ;  $\text{Rate}_2 = k[2A]^n[1/2B]^m$ 

$$\therefore \frac{\text{Rate}_2}{\text{Rate}_1} = \frac{k[2A]^n[1/2B]^m}{k[A]^n[B]^m} = [2]^n[1/2]^m = 2^n \cdot 2^{-m} = 2^{n-m}$$

11. (b)  $r = k[\text{O}_2][\text{NO}]^2$ . When the volume is reduced to 1/2, the conc. will double

$$\therefore \text{Newrate} = k[2\text{O}_2][2\text{NO}]^2 = 8k[\text{O}_2][\text{NO}]^2$$

The new rate increases to eight times of its initial.

12. (c) As the concentration of reactant decreases from 0.8 to 0.4 in 15 minutes hence the  $t_{1/2}$  is 15 minutes. To fall the concentration from 0.1 to 0.025 we need two half lives i.e., 30 minutes.

13. (d) The velocity constant depends on temperature only. It is independent of concentration of reactants.

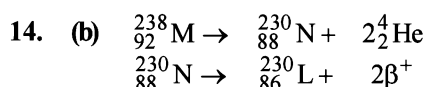
The number of neutrons in element L =  $230 - 86 = 144$

15. (a)  $N_t = N_0 \left(\frac{1}{2}\right)^n$  where n is number of half life periods.

$$n = \frac{\text{Total time}}{\text{half life}} = \frac{24}{4} = 6$$

$$\therefore N_t = 200 \left(\frac{1}{2}\right)^6 = 3.125\text{g.}$$

16. (b) Such reaction in which two lighter nucleus are fused together to form a heavier nuclei is called nuclear fusion.

**NOTE :** In hydrogen bomb, a mixture of deuterium oxide ( $\text{H}_2\text{O}$ ) and tritium Oxide ( $\text{T}_2\text{O}$ ) is enclosed in a space surrounding an ordinary atomic bomb. The temperature produced by the atomic bomb initiates the fusion reaction between  ${}_1\text{H}^3$  and  ${}_1\text{H}^2$  releasing a large amount of energy.

17. (d) The molecularity of a reaction is the number of reactant molecules taking part in a single step of the reaction.

**NOTE :** The reaction involving two different reactant can never be unimolecular.

18. (d) The graph show that reaction is exothermic.

$$\log k = \frac{-\Delta H}{RT} + I$$

For exothermic reaction  $\Delta H < 0$

$\therefore \log k$  Vs  $\frac{1}{T}$  would be negative straight line with positive slope.

19. (b)  ${}_{12}\text{Mg}^{24} \longrightarrow {}_{11}\text{Na}^{23} + {}_1\text{H}^1.$

20. (c)  $t_{1/4} = \frac{2.303}{K} \log \frac{1}{3/4} = \frac{2.303}{K} \log \frac{4}{3}$

$$= \frac{2.303}{K} (\log 4 - \log 3) = \frac{2.303}{K} (2 \log 2 - \log 3)$$

$$= \frac{2.303}{K} (2 \times 0.301 - 0.4771) = \frac{0.29}{K}$$

21. (a) Since the reaction is 2nd order w.r.t CO. Thus, rate law is given as.

$$r = k[\text{CO}]^2$$

Let initial concentration of CO is a i.e.  $[\text{CO}] = a$

$$\therefore r_1 = k(a)^2 = ka^2$$

when concentration becomes doubled, i.e.  $[\text{CO}] = 2a$

$$\therefore r_2 = k(2a)^2 = 4ka^2 \quad \therefore r_2 = 4r_1$$

So, the rate of reaction becomes 4 times.

22. (c) In Arrhenius equation  $K = A e^{-E/RT}$ , E is the energy of activation, which is required by the colliding molecules to react resulting in the formation of products.

23. (c)  ${}_{92}^{238}\text{U} \xrightarrow{-\alpha} {}_{90}^{234}\text{Th} \xrightarrow{-2\beta} {}_{92}^{234}\text{U}$

24. (b) (i)  $\text{NO}(\text{g}) + \text{Br}_2(\text{g}) \rightleftharpoons \text{NOBr}_2(\text{g})$

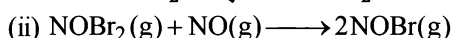

Rate law equation =  $k[\text{NOBr}_2][\text{NO}]$

But  $\text{NOBr}_2$  is intermediate and must not appear in the rate law equation

$$\text{from 1st step } K_C = \frac{[\text{NOBr}_2]}{[\text{NO}][\text{Br}_2]}$$

$$\therefore [\text{NOBr}_2] = K_C [\text{NO}][\text{Br}_2]$$

$$\therefore \text{Rate law equation} = k \cdot K_C [\text{NO}]^2 [\text{Br}_2]$$

hence order of reaction is 2 w.r.t. NO.

25. (a)  $\Delta H_R = E_f - E_b = 180 - 200 = -20 \text{ kJ/mol}$

The nearest correct answer given in choices may be obtained by neglecting sign.

26. (b) For a first order reaction  $t_{1/2} = \frac{0.693}{K}$  i.e. for a first

order reaction  $t_{1/2}$  does not depend up on the concentration. From the given data, we can say that order of reaction with respect to B = 1 because change in concentration of B does not change half life.

Order of reaction with respect to A = 1 because rate of reaction doubles when concentration of B is doubled keeping concentration of A constant.

$\therefore$  Order of reaction = 1 + 1 = 2 and units of second order reaction are  $\text{L mol}^{-1} \text{sec}^{-1}$ .

27. (a) Suppose activity of safe working = A

Given  $A_0 = 10A$

$$\lambda = \frac{0.693}{t_{1/2}} = \frac{0.693}{30}$$

$$t_{1/2} = \frac{2.303}{\lambda} \log \frac{A_0}{A} = \frac{2.303}{0.693/30} \log \frac{10A}{A}$$

$$= \frac{2.303 \times 30}{0.693} \times \log 10 = 100 \text{ days.}$$

28. (b) **NOTE :** Isotopes are atoms of same element having same atomic number but different atomic masses. Neutron has atomic number 0 and atomic mass 1. So loss of neutron will generate isotope. e.g.,

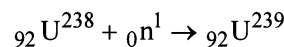

29. (b) The rates of reactions for the reaction

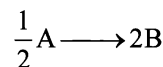

can be written either as

$$-2 \frac{d}{dt}[\text{A}] \quad \text{with respect to 'A'}$$

$$\text{or } \frac{1}{2} \frac{d}{dt}[\text{B}] \quad \text{with respect to 'B'}$$

From the above, we have

$$-2 \frac{d}{dt}[\text{A}] = \frac{1}{2} \frac{d}{dt}[\text{B}] \quad \text{or} \quad -\frac{d}{dt}[\text{A}] = \frac{1}{4} \frac{d}{dt}[\text{B}]$$

i.e., correct answer is (b)



30. (b) For first order reaction,

$$k = \frac{2.303}{t} \log \frac{100}{100-99}$$

$$\frac{0.693}{6.93} = \frac{2.303}{t} \log \frac{100}{1}$$

$$\frac{0.693}{6.93} = \frac{2.303 \times 2}{t} \Rightarrow t = 46.06 \text{ min}$$

31. (c) For the reaction

A → Product, given  $t_{1/2} = 1$  hour  
for a zero order reaction

$$t_{\text{completion}} = \frac{[A_0]}{k} = \frac{\text{initial conc.}}{\text{rate constant}}$$

$$\therefore t_{1/2} = \frac{[A_0]}{2k} \text{ or } k = \frac{[A_0]}{2t_{1/2}} = \frac{2}{2 \times 1} = 1 \text{ mol lit}^{-1} \text{ hr}^{-1}$$

Further for a zero order reaction

$$k = \frac{dx}{dt} = \frac{\text{change in concentration}}{\text{time}}$$

$$1 = \frac{0.50 - 0.25}{\text{time}} \quad \therefore \text{time} = 0.25 \text{ hr.}$$

32. (d) Since the slow step is the rate determining step hence if we consider option (1) we find

$$\text{Rate} = k[\text{Cl}_2][\text{H}_2\text{S}]$$

Now if we consider option (2) we find

$$\text{Rate} = k[\text{Cl}_2][\text{HS}^-] \quad \dots(1)$$

From equation (i)

$$k = \frac{[\text{H}^+][\text{HS}^-]}{\text{H}_2\text{S}} \text{ or } [\text{HS}^-] = \frac{k[\text{H}_2\text{S}]}{\text{H}^+}$$

Substituting this value in equation (1) we find

$$\text{Rate} = k[\text{Cl}_2]K \frac{[\text{H}_2\text{S}]}{\text{H}^+} = k' \frac{[\text{Cl}_2][\text{H}_2\text{S}]}{[\text{H}^+]}$$

hence only, mechanism (1) is consistent with the given rate equation.

33. (c) Since for every 10°C rise in temperature rate doubles for 50°C rise in temp increase in reaction rate =  $2^5 = 32$  times

34. (b) For a first order reaction

$$k = \frac{2.303}{t} \log \frac{a}{a-x} = \frac{2.303}{40} \log \frac{0.1}{0.025}$$

$$= \frac{2.303}{40} \log 4 = \frac{2.303 \times 0.6020}{40} = 3.47 \times 10^{-2}$$

$$R = K(A)^1 = 3.47 \times 10^{-2} \times 0.01 = 3.47 \times 10^{-4}$$

35. (a) Activation energy can be calculated from the equation

$$\frac{\log k_2}{\log k_1} = \frac{E_a}{2.303R} \left( \frac{1}{T_1} - \frac{1}{T_2} \right)$$

$$\text{given } \frac{k_2}{k_1} = 2 \quad T_2 = 310 \text{ K} \quad T_1 = 300 \text{ K}$$

$$= \log 2 = \frac{-E_a}{2.303 \times 8.314} \left( \frac{1}{310} - \frac{1}{300} \right)$$

$$E_a = 53598.6 \text{ J/mol} = 53.6 \text{ kJ/mol.}$$

36. (d) Let rate of reaction =  $\frac{d[C]}{t} = k[A]^x[B]^y$

Now from the given data

$$1.2 \times 10^{-3} = k[0.1]^x[0.1]^y \quad \dots(i)$$

$$1.2 \times 10^{-3} = k[0.1]^x[0.2]^y \quad \dots(ii)$$

$$2.4 \times 10^{-3} = k[0.2]^x[0.1]^y \quad \dots(iii)$$

Dividing equation (i) by (ii)

$$\Rightarrow \frac{1.2 \times 10^{-3}}{1.2 \times 10^{-3}} = \frac{k[0.1]^x[0.1]^y}{k[0.1]^x[0.2]^y}$$

We find,  $y = 0$

Now dividing equation (i) by (iii)

$$\Rightarrow \frac{1.2 \times 10^{-3}}{2.4 \times 10^{-3}} = \frac{k[0.1]^x[0.1]^y}{k[0.2]^x[0.1]^y}$$

We find,  $x = 1$

$$\text{Hence } \frac{d[C]}{dt} = k[A]^1[B]^0$$

37. (c) Reactions of higher order (>3) are very rare due to very less chances of many molecules to undergo effective collisions.

38. (d)  $\text{H}_2\text{O}_2(\text{aq}) \rightarrow \text{H}_2\text{O}(\text{aq}) + \frac{1}{2} \text{O}_2(\text{g})$

For a first order reaction

$$k = \frac{2.303}{t} \log \frac{a}{(a-x)}$$

Given  $a = 0.5$ ,  $(a-x) = 0.125$ ,  $t = 50$  min

$$\therefore k = \frac{2.303}{50} \log \frac{0.5}{0.125}$$

$$= 2.78 \times 10^{-2} \text{ min}^{-1}$$

$$r = k[\text{H}_2\text{O}_2] = 2.78 \times 10^{-2} \times 0.05$$

$$= 1.386 \times 10^{-3} \text{ mol min}^{-1}$$

Now

$$-\frac{d[\text{H}_2\text{O}_2]}{dt} = \frac{d[\text{H}_2\text{O}]}{dt} = \frac{2d[\text{O}_2]}{dt}$$

$$\therefore \frac{2d[\text{O}_2]}{dt} = -\frac{d[\text{H}_2\text{O}_2]}{dt}$$

$$\therefore \frac{d[\text{O}_2]}{dt} = \frac{1}{2} \times \frac{d[\text{H}_2\text{O}_2]}{dt}$$

$$= \frac{1.386 \times 10^{-3}}{2} = 6.93 \times 10^{-4} \text{ mol min}^{-1}$$

## Section-A : JEE Advanced/ IIT-JEE

- A** 1. Tin      2. Aluminium      3. Magnesia and lime; Calcium silicate      4. sintering, smelting
- C** 1. (c)      2. (c)      3. (b)      4. (a)      5. (c)      6. (b)
7. (d)      8. (b)      9. (a)
- D** 1. (b, d)      2. (a, c, d)      3. (c, d)      4. (b,c,d)      5. (b,c,d)      6. (a, b, c)
- F** 1. (A)- p, r; (B) - p, r; (C) - q; (D) - s      2. (A) - p; (B) - q; (C) - p, r; (D) - p, s
3. (A)- p,q,s, (B)- t, (C)- q, r, (D)- r

## Section-B : JEE Main/ AIEEE

1. (c)      2. (b)      3. (c)      4. (b)      5. (c)      6. (c)      7. (d)      8. (b)
9. (b)      10. (a)

## Section-A JEE Advanced/ IIT-JEE

### A. Fill in the Blanks

1. **Tin.** It is  $\text{SnO}_2$ . [The formula of Cassiterite ore is  $\text{SnO}_2$ ]
2. **Aluminium**

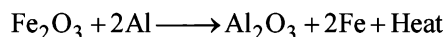

[Thermite reaction]

3. **Magnesia and lime; calcium silicate**

**NOTE :** The lining of converter is made of magnesia & lime. Slag formed consists of  $\text{CaSiO}_3$ .

4. **sintering, smelting.**

### C. MCQs with One Correct Answer

1. (c) Malachite is  $\text{CuCO}_3 \cdot \text{Cu}(\text{OH})_2$  it is ore of copper.
2. (c) Al reduces  $\text{Fe}_2\text{O}_3$  or  $\text{Cr}_2\text{O}_3$  to respective metals and acts as a reducing agent.
- $$\text{Fe}_2\text{O}_3 + 2\text{Al} \rightarrow \text{Al}_2\text{O}_3 + 2\text{Fe}$$
3. (b) **NOTE :** During the extraction of copper, iron is present in the ore as impurity (FeS). The ore together with a little coke and silica is smelted; FeS present as impurity in the ore is oxidized to iron oxide, which then reacts with silica to form fusible ferrous silicate which is removed as slag.

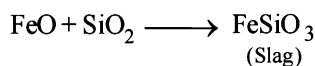
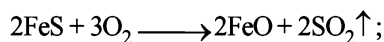

4. (a)  $\text{MgCl}_2 \rightarrow \text{Mg}^{+2} + 2\text{Cl}^-$   
(fused anhydrous)

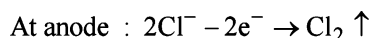
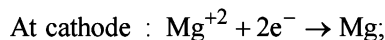

5. (c) Cuprite :  $\text{Cu}_2\text{O}$ ; Chalcocite :  $\text{Cu}_2\text{S}$ ; Chalcopyrite :  $\text{CuFeS}_2$ ; Malachite :  $\text{Cu}(\text{OH})_2 \cdot \text{CuCO}_3$ . We see that  $\text{CuFeS}_2$  contains both Cu and Fe.
6. (b) **NOTE :** Extraction of Zn from ZnS (Zinc blende) is achieved by roasting followed by reduction with carbon.
- $$2\text{ZnS} + 3\text{O}_2 \longrightarrow 2\text{ZnO} + 2\text{SO}_2$$
- $$\text{ZnO} + \text{C} \longrightarrow \text{Zn} + \text{CO}$$
7. (d) (i) Haematite is  $\text{Fe}_2\text{O}_3$  in which Fe is present in III oxidation state.  
(ii) Magnetite ( $\text{Fe}_3\text{O}_4$ ) is an equimolar mixture of FeO and  $\text{Fe}_2\text{O}_3$ .  
Oxidation state of Fe in FeO is II.  
Oxidation state of Fe in  $\text{Fe}_2\text{O}_3$  is III.
8. (b) The reactions involved in cyanide extraction process are :

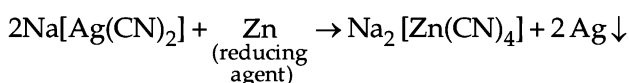
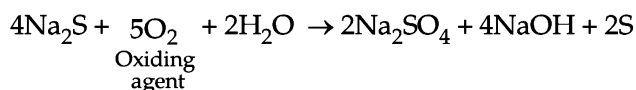
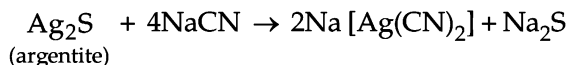

## General Principles and Processes of Isolation of Elements

9. (a) Silver, copper and lead are commonly found in earth's crust as  $\text{Ag}_2\text{S}$  (silver glance),  $\text{CuFeS}_2$  (copper pyrites) and  $\text{PbS}$  (galena)

### D. MCQs with One or More Than One Correct

- (b, d) Both Mg and Al have their reduction potentials less than that of water [ $E^\circ = -0.83 \text{ V}$ ]. Hence, their ions in the aqueous solution can not be reduced. Instead water will be reduced :  $2\text{H}_2\text{O} + 2e^- \rightarrow \text{H}_2 + 2\text{OH}^-$
- (a, c, d)
- (c, d) Al from  $\text{Al}_2\text{O}_3$  and Mg from  $\text{MgCO}_3 \cdot \text{CaCO}_3$  are separately extracted by electrolytic reduction.
- (b, c, d)  $\text{Cu}_2\text{S} + 2\text{Cu}_2\text{O} \rightarrow 6\text{Cu} + \text{SO}_2$   
 $\text{Cu}_2\text{S} + 2\text{CuO} \rightarrow 4\text{Cu} + \text{SO}_2$   
 $\text{Cu}_2\text{S} + \text{CuSO}_4 \rightarrow 3\text{Cu} + 2\text{SO}_2$
- (b, c, d) In electrolytic refining of blister Cu, acidified  $\text{CuSO}_4$  is used as electrolyte, pure Cu deposits at cathode and impurities settle as anode mud.
- (a, b, c)

Copper pyrite [ $\text{CuFeS}_2$ ]

↓  
Crushing into fine powder

Concentrated by froth floatation process

↓

Roasting take place in reverberatory furnace

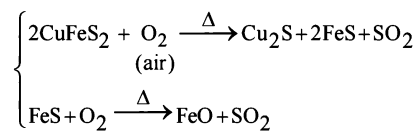

↓ Smelting  $\left[ \begin{array}{l} \text{Iron is removed as slag of } \text{FeSiO}_3 \\ \text{FeO} + \text{SiO}_2 (\text{flux}) \xrightarrow{\Delta} \text{FeSiO}_3 (\ell) (\text{slag}) \end{array} \right]$

Copper matte ( $\text{Cu}_2\text{S} + \text{FeS}$ )

↓ Self reduction  $\left[ \begin{array}{l} \text{Self reduction occurs in Bessemer converter} \\ 2\text{Cu}_2\text{S} + 3\text{O}_2 \longrightarrow 2\text{Cu}_2\text{S} + 2\text{SO}_2 (\uparrow) \\ \text{Cu}_2\text{S} + 2\text{Cu}_2\text{O} \longrightarrow 6\text{Cu} + \text{SO}_2 (\uparrow) \end{array} \right]$

(Blister copper)

↓

Refining of blister copper is done by poling followed by electrorefining but not by carbon reduction method.

### E. Subjective Problems

- (a) Galena is roasted in excess of air in a reverberatory furnace

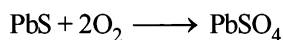
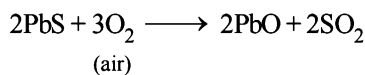

It is followed by self reduction

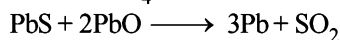
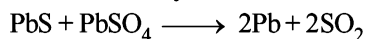

- (b) (i) Silver  $\longrightarrow$  (D) Amalgamation  
(ii) Calcium  $\longrightarrow$  (A) Fused salt electrolysis  
(iii) Zinc  $\longrightarrow$  (B) Carbon reduction  
(iv) Iron  $\longrightarrow$  (C) Carbon monoxide reduction  
(v) Copper  $\longrightarrow$  (E) Self reduction
- Bleaching agent  $\longrightarrow$  Chlorine  
Smelling salt  $\longrightarrow$  Ammonium carbonate  
Cryolite  $\longrightarrow$  Aluminium  
Bell metal  $\longrightarrow$  Tin  
Fluorspar  $\longrightarrow$  Calcium  
Fertilizer  $\longrightarrow$  Ammonium phosphate  
Anthracite  $\longrightarrow$  Carbon
  - (i) because they occur as oxides, carbonates, sulphides which have to be calcined or roasted.  
(ii) **NOTE** : *Zone refining* is based on the difference in solubility of impurities in molten and solid state of the metal. This method is used for obtaining metals of very high purity.  
Ge, Si and Ga used as semi-conductors are refined in this manner. These metals can be easily melted and can easily crystallise out from the melt form.  
(iii) Excess of Air (used during roasting) is necessary for converting chalcocite (a sulphide ore) to oxide. Calcination does not convert it to oxide.

### 4. Recovery of Pb from galena :

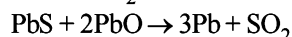
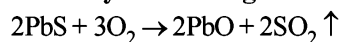

### F. Match the Following

- (A)- p, r; (B) - p, r; (C) - q; (D) - s

**NOTE** : The oxides and sulphides of less active metals like Hg, Cu & Pb are unstable to heat and hence no reducing agent is required. They undergo self reduction.

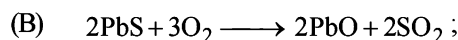
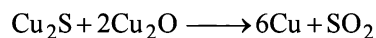
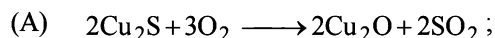

Hence (A)  $\rightarrow$  (p), (r)

**NOTE** : The oxides of less electropositive metals like Pb, Zn, Fe, Sn, Cu, etc. are reduced by strongly heating them with coke or coal.

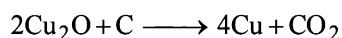
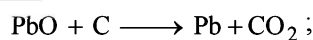

Hence (B)  $\rightarrow$  (p), (r)

Extraction from argentite ( $\text{Ag}_2\text{S}$ )

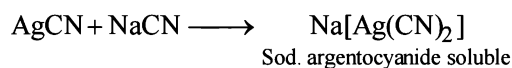
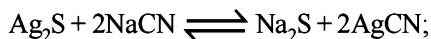

Zn, being more electropositive than Ag, displaces Ag from the complex.

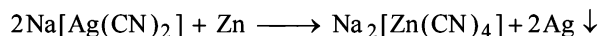

Hence (C)  $\rightarrow$  (q)

Among the halides of boron,  $\text{BI}_3$  is unstable because of the large size of Iodine and small size of boron atom. Hence it decomposes to give boron. Thus, (D)  $\rightarrow$  (s).

2. (A) - p; (B) - q; (C) - p, r; (D) - p, s

3. A-(p, q, s), B-(t), C-(q, r), D-(r)

Siderite	$\rightarrow$	$\text{FeCO}_3$
Malachite	$\rightarrow$	$\text{CuCO}_3 \cdot \text{Cu}(\text{OH})_2$
Bauxite	$\rightarrow$	$\text{Al}_2\text{O}_3 \cdot x\text{H}_2\text{O}$ or $\text{AlO}_x(\text{OH})_{3-2x} \quad 0 < x < 1$
Calamine	$\rightarrow$	$\text{ZnCO}_3$
Argentite	$\rightarrow$	$\text{Ag}_2\text{S}$

## Section-B JEE Main/ AIEEE

1. (c) Pure aluminium can be obtained by electrolysis of a mixture containing alumina, cryolite and fluorspar in the ratio 20 : 24 : 20. The fusion temperature of this mixture is  $900^\circ\text{C}$  and it is a good conductor of electricity.
2. (b) Silver ore forms a soluble complex with NaCN from which silver is precipitated using scrap zinc.
 
$$\text{Ag}_2\text{S} + 2\text{NaCN} \rightarrow \text{Na}[\text{Ag}(\text{CN})_2] \xrightarrow{\text{Zn}} \text{Na}_2[\text{Zn}(\text{CN})_4] + \text{Ag} \downarrow$$

sodargentocyanide  
(soluble)
3. (c) **NOTE :** Galena is  $\text{PbS}$  and thus purified by froth floatation method.  
Froth floatation method is used to concentrate sulphide ores. This method is based on the preferential wetting properties with the frothing agent and water.
4. (b) During the process of electrolytic refining Ag and Au are obtained as anode mud.
5. (c) **NOTE :** The reduction of metal sulphides by carbon reduction process is not spontaneous because  $\Delta G$  for such a process is positive. The reduction of metal oxide by carbon reduction process is spontaneous as  $\Delta G$  for such a process is negative.  
From this we find that on thermodynamic considerations  $\text{CO}_2$  is more stable than  $\text{CS}_2$  and the metal sulphides are more stable than corresponding oxides.  
In view of above the factor listed in choice (c) is incorrect and so is of no significance.  
Hence the correct answer is (c)
6. (c) Moles of HCl taken =  $20 \times 0.1 \times 10^{-3} = 2 \times 10^{-3}$   
Moles of HCl neutralised by NaOH solution =  $15 \times 0.1 \times 10^{-3} = 1.5 \times 10^{-3}$   
Moles of HCl neutralised by ammonia =  $2 \times 10^{-3} - 1.5 \times 10^{-3} = 0.5 \times 10^{-3}$   

$$\% \text{ of nitrogen} = \frac{1.4 \times N \times V}{\text{w.t. of Substance}} \times 100$$

$$= \frac{1.4 \times 0.5 \times 10^{-3}}{29.5 \times 10^{-3}} \times 100 = 23.7\%$$
7. (d) Van Arkel is a method in which heat treatment is used to purify metal in this process metals are converted into other metal compound for loosely coupled like as iodine to make metal iodide which are easily decomposed and give pure metal.  
The process is known as Van Arkel method.
8. (b) On electrolysis of aqueous solution of s-block elements  $\text{H}_2$  gas discharge at cathode.  

$$\text{At cathode: } \text{H}_2\text{O} + e^- \rightarrow \frac{1}{2}\text{H}_2 + \text{OH}^-$$
9. (b) In the metallurgy of aluminium, purified  $\text{Al}_2\text{O}_3$  is mixed with  $\text{Na}_3\text{AlF}_6$  or  $\text{CaF}_2$  which lowers the melting point of the mix and brings conductivity.
10. (a) Froth floatation method is mainly applicable for sulphide ores.
  - (1) Malachite ore :  $\text{Cu}(\text{OH})_2 \cdot \text{CuCO}_3$
  - (2) Magnetite ore :  $\text{Fe}_3\text{O}_4$
  - (3) Siderite ore :  $\text{FeCO}_3$
  - (4) Galena ore :  $\text{PbS}$  (Sulphide Ore)

## 16

## The p-Block Elements

**Section-A : JEE Advanced/ IIT-JEE**

- A** 1. -3      2.  $\text{NaIO}_3$       3. HF      4.  $\text{KI}_3$       5. sodium hydroxide  
6. white/yellow      7. hypobromous, bromide      8. cross-linking      9. two  
10. silicones      11. 4      12. Nitric oxide      13. trialkylchlorosilanol      14. fullerene  
15.  $\text{I}_3$  complex ion      16. glass      17. inert-pair effect
- B** 1. F      2. F      3. F      4. T      5. F      6. T      7. F      8. T      9. F      10. T  
11. T      12. T      13. F
- C** 1. (c)      2. (b)      3. (a)      4. (c)      5. (a)      6. (d)      7. (c)      8. (d)      9. (d)      10. (c)  
11. (b)      12. (b)      13. (a)      14. (c)      15. (b)      16. (b)      17. (d)      18. (a)      19. (b)      20. (d)  
21. (c)      22. (b)      23. (d)      24. (c)      25. (c)      26. (b)      27. (d)      28. (a)      29. (b)      30. (c)  
31. (d)      32. (c)      33. (b)      34. (c)      35. (c)      36. (c)      37. (d)      38. (c)      39. (a)      40. (a)  
41. (c)      42. (b)      43. (c)      44. (b)      45. (b)      46. (c)      47. (c)      48. (b)      49. (b)      50. (b)  
51. (d)      52. (b)      53. (b)      54. (d)      55. (b)      56. (c)      57. (d)      58. (b)      59. (a)      60. (c)  
61. (b)      62. (a)
- D** 1. (a, b)      2. (a, d)      3. (a, d)      4. (b, c)      5. (b)      6. (a, b, d)      7. (a, c, d)      8. (c)      9. (a, b)      10. (a, b, c)  
11. (a, c, d)      12. (b, d)      13. (a, c, d)      14. (a, b, c)      15. (b, d)      16. (b, c)      17. (b)      18. (a, c, d)      19. (b, d)
- E** 14. (i)  $\text{HI} < \text{HBr} < \text{HCl} < \text{HF}$ ,  
(ii)  $\text{HOCl} < \text{HOClO} < \text{HOClO}_2 < \text{HOClO}_3$   
(iii)  $\text{SiO}_2 < \text{CO}_2 < \text{N}_2\text{O}_5 < \text{SO}_3$ ,  
(iv)  $\text{CCl}_4 < \text{MgCl}_2 < \text{AlCl}_3 < \text{SiCl}_4 < \text{PCl}_5$   
17. [A]- $\text{PbO}$ , [B]-heat in the absence of air      19. 12, 4      22.  $\text{M} = \text{As}, \text{N} = \text{AsH}_3$   
27. vanadium pentoxide  
28.  $\text{Ca(OH)}_2, \text{NH}_4\text{HCO}_3, \text{Na}_2\text{CO}_3, \text{NH}_4\text{Cl}, \text{CaCl}_2$       32.  $\text{BCl}_3$  or  $\text{BBr}_3, \text{B}_2\text{H}_6$   
A      B      C      D      E  
36. O.N. of Pb in  $\text{PbO}$  is +2  
37.  $\text{NaHSO}_3$  (OS = +4),  $\text{Na}_2\text{SO}_3$  (OS = +4),  $\text{Na}_2\text{S}_2\text{O}_3$  (OS = -2),  $\text{Na}_2\text{S}_4\text{O}_6$  (OS = +2.5)      39. 1008 g  
A      B      C      D  
41. Conc.  $\text{H}_2\text{SO}_4, \text{Br}_2, \text{NO}_2^+, \text{TNT}$   
A      B      C      D
- F** 1. (A)-t; (B)-s; (C)-v; (D)-u      2. (A)-q; (B)-s; (C)-p; (D)-r  
3. (A)-p, r, t; (B)-s, t; (C)-p, q, r; (D)-p, r, s      4. (d)
- G** 1. (a)      2. (c)      3. (a)      4. (c)      5. (c)      6. (b)      7. (a)      8. (c)      9. (a)      10. (a)
- H** 1. (b)      2. (c)      3. (a)      4. (c)      5. (c)      6. (a)      7. (c)
- I** 1. 6      2. 3      3. 5      4. 4      5. 8      6. 6

**Section-B : JEE Main/ AIEEE**

1. (c)      2. (d)      3. (a)      4. (c)      5. (d)      6. (d)      7. (d)      8. (a)      9. (c)      10. (a)  
11. (b)      12. (d)      13. (d)      14. (c)      15. (c)      16. (b)      17. (b)      18. (c)      19. (c)      20. (b)  
21. (d)      22. (d)      23. (b)      24. (b)      25. (b)      26. (d)      27. (a)      28. (c)      29. (d)      30. (a)  
31. (d)      32. (a)      33. (c)      34. (c)      35. (a)      36. (b)      37. (b)      38. (c)      39. (b)      40. (c)      41. (c)

# Section-A JEE Advanced/ IIT-JEE

## A. Fill in the Blanks

- 3;
- $\text{NaIO}_3$   

$$3\text{I}_2 + 6\text{NaOH} \xrightarrow{\text{(hot)}} 5\text{NaI} + \text{NaIO}_3 + 3\text{H}_2\text{O}$$
- HF;** HF is the weakest of the three, because the ionisation (*i.e.* acidic character) of HX is a multistep process and when its  $\Delta H$ , heat of ionisation, is calculated it comes out to be the minimum. This is due to the strong H–F bond, large heat of hydration (because of H-bonding) and low value of electron affinity of F-atom.
- $\text{KI}_3$ ;** complexes are more soluble in water as compared to normal salts.  $[\text{KI} + \text{I}_2 \longrightarrow \text{KI}_3]$
- sodium hydroxide;**  

$$\text{Al} + 2\text{NaOH} + 2\text{H}_2\text{O} \longrightarrow 2\text{NaAlO}_2 + 3\text{H}_2$$
- white/ yellow; NOTE :** In white phosphorus, each phosphorus atom is linked to the other three atoms by covalent bonds. PPP bond angle is  $60^\circ$ , due to which the molecule remains under strain and hence is active in nature.

- Hypobromous; bromite.**  $\text{HBrO} \rightleftharpoons \text{H}^+ + \text{BrO}^-$
- cross-linking;**

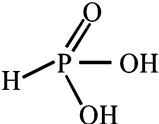
- two;**  [It contains two replaceable hydrogens.]

- Silicones;**

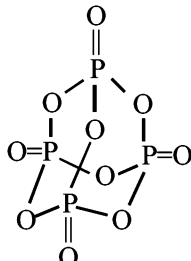
- four.** 

In each P atom is linked to 4 oxygen atoms

- Nitric oxide. [NO]**  
The mixture containing  $\text{SO}_2$ , air and nitric oxide, when treated with steam, sulphuric acid is formed.  

$$2\text{SO}_2 + \underbrace{\text{O}_2 + 2\text{H}_2\text{O}}_{\text{Air}} + [\text{NO}] \xrightarrow{\text{(Catalyst)}} 2\text{H}_2\text{SO}_4 + [\text{NO}]$$
- Trialkylchlorosilanol;** The hydrolysis of  $\text{R}_3\text{SiCl}$ , yields  $\text{R}_3\text{Si}(\text{OH})$  which condenses to give  $\text{R}_3\text{Si}-\text{O}-\text{SiR}_3$   

$$\text{R}_3\text{Si}-\text{O}-\boxed{\text{H}+\text{H}-\text{O}}-\text{SiR}_3 \longrightarrow \text{R}_3-\text{Si}-\text{O}-\text{Si}-\text{R}_3$$
- Fullerene**
- $\text{I}_3^-$  complex ion;**  $\text{I}_2 + \text{I}^- \longrightarrow \text{I}_3^-$

- glass**
- inert-pair effect ;** When  $ns^2$  electrons of outermost shell do not participate in bonding it is called inert pair and the effect is called inert pair effect.

## B. True/False

- False :** Red phosphorus is **polymeric substance**. It exist as chains of  $\text{P}_4$  tetrahedra linked together. Therefore, it is less volatile than white phosphorus.
- False :**  $\text{PbO}_2$  is a dioxide and it **does not** give hydrogen peroxide when it reacts with a dilute acid.  

$$\text{PbO}_2 + 4\text{HCl} \rightarrow \text{PbCl}_2 + \text{Cl}_2 + 2\text{H}_2\text{O}$$
- False :**  $\text{CCl}_4$  gives phosgene with superheated steam  

$$\text{CCl}_4 + \text{H}_2\text{O} \rightarrow \text{COCl}_2 + 2\text{HCl}$$
- True :**  $\text{Fe} + 2\text{HCl} \rightarrow \text{FeCl}_2 + \text{H}_2$  [In  $\text{FeCl}_2$ , Fe is in +2 state.]
- False :** Since halogens have high electron affinities, they easily pick up electrons from other substances. Hence halogens are **oxidising agents**. The oxidising power decreases from fluorine to iodine. Since fluorine is the strongest oxidising agent it will oxidise any of the other halide ions in solution or when dry. Similarly,  $\text{Cl}_2$  will displace  $\text{Br}^-$  and  $\text{I}^-$  ions from their solutions and  $\text{Br}_2$  will displace  $\text{I}^-$  ions.

**NOTE :** In general, a halogen of low atomic number will oxidise the halide ion of higher atomic number.

- True :**  
**NOTE :** The central element in the metal hydrides of group 15 elements is although in  $sp^3$  hybrid state, the H–M–H bond angle is less than the normal tetrahedral bond angle of  $109^\circ 28'$ ; *e.g.* the bond angle, H–N–H in  $\text{NH}_3$  is  $106^\circ 45'$ . This is due to greater repulsion between a lone pair and a bond pair of electrons than between the two bond pairs of electrons.

The decrease in bond angle from  $106^\circ 45'$  in ammonia to about  $90^\circ$  in  $\text{AsH}_3$  can be explained by the fact that in the latter case  $sp^3$  hybridisation becomes less and less distinct with the increasing size of their electron clouds, *i.e.*, pure  $p$  orbitals (instead of  $sp^3$  hybrid orbitals) are used for M–H bonding and the lone pair of electrons is present in spherical  $s$ -orbital.

- False :** because of its high thermal stability.  $\text{CCl}_4$  is most stable as compared to other tetrachlorides of the group.
- True :** Graphite is better lubricant on the moon than on the earth because of lack of gravitation pull on the moon, where friction is already less than earth.
- False :** The structure of  $\text{Al}_2\text{Cl}_6$  is as under :

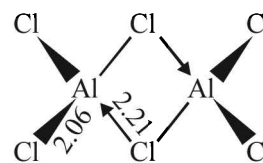

Structure of  $\text{Al}_2\text{Cl}_6$

Bond distance between aluminium-chlorine bond forming bridge is greater (2.21 Å) than the distance between aluminium-chlorine bond present in the end (2.06 Å).

10. **True** : The molecule of NO has eleven valence electrons (5 due to N and 6 due to O). It is impossible for all of them to be paired, hence the nitric oxide molecule contains an *odd electron* which makes gaseous nitric oxide *paramagnetic*.



**NOTE** : In the liquid and solid states, nitric oxide is polymerised to a dimer which is *diamagnetic*.

11. **True** : In diamond, each carbon atom is in  $sp^3$  hybridised state and is linked to four other neighbouring carbon atoms held at the corners of a regular tetrahedron by covalent bonds. Owing to very strong covalent bonds by which the atoms are held together, **diamond is the hardest substance known**. Graphite has a two dimensional sheet like structure and carbon in  $sp^2$  hybridised state is attached to three other carbon atoms by three  $\sigma$  bonds forming a hexagonal planar structure. Due to wide separation and weak interlayer bonds, the two adjacent layers can easily slide over each other; hence **graphite is soft**.
12. **True** : The property of catenation in carbon is due to the fact that in carbon atom, the number of valence electrons (4) is equal to the number of valence orbitals (one  $2s$  + three  $2p$ ). Hence carbon in the tetravalent state is fully saturated, *i.e.*, it has neither any vacant orbital nor any lone pair of electrons on its atom due to which the C – C bond is extremely stable.
- NOTE** : The reason for greater tendency of carbon for catenation than silicon may further be explained by the fact that the C – C bond energy is approximately of the same magnitude as the energies of the bond between C and other elements. On the other hand, the Si – Si bond is weaker than the bonds between silicon and other elements.
13. **False** : None amongst, HBr and HI, HI exhibit hydrogen bonding. HI is a stronger acid than HBr because of its higher dissociation constant,  $K_a$ . HI has a stronger tendency to release protons to water molecules and hence is a stronger acid.

### C. MCQs with One Correct Answer

1. (c)  $\text{NO} + \text{O}_2 \longrightarrow \text{NO}_2$   
Nitric oxide (colourless)                      Nitrogen dioxide (reddish brown coloured)
2. (b) Temporary hardness of water is due to presence of bicarbonates of Ca and Mg and it is removed by adding  $\text{Ca}(\text{OH})_2$  to hard water and precipitating these soluble bicarbonates in the form of insoluble salts.
- $$\text{Ca}(\text{HCO}_3)_2 \xrightarrow{\Delta} \text{CaCO}_3 \downarrow + \text{CO}_2 \uparrow + \text{H}_2\text{O}$$
- $$\text{Mg}(\text{HCO}_3)_2 \xrightarrow{\Delta} \text{Mg}(\text{OH})_2 \downarrow + 2\text{CO}_2 \uparrow$$
3. (a) Due to highest bond dissociation energy.

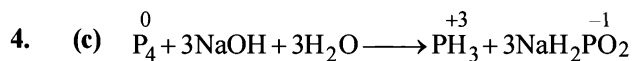

It is redox reaction.

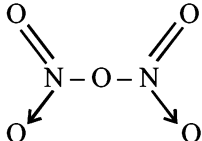
- (i) Oxidation number increases during oxidation reaction and decreases during reduction reaction.  
(ii) In a neutralisation reaction acids and bases reacts together to form salt and water.
5. (a)  $\therefore \text{Cl}_2$  is more reactive than bromine.  
6. (d) All are colourless gases.  
7. (c)  
8. (d) None; it reacts with all given compounds. It forms addition compounds with them. It can be dried over any metal oxide.  
9. (d) HI and HBr (in that order) are the strongest reducing hydracids and hence they reduce  $\text{H}_2\text{SO}_4$ . HCl is quite stable and hence is oxidised by strong oxidising agent like  $\text{KMnO}_4$ . HF is not a reducing agent. In the smallest  $\text{F}^-$  ion, the electron which is to be removed during oxidation is closest to the nucleus and therefore most difficult to be removed. Therefore, HF is a poor reducing agent.  
10. (c)  $\text{AlCl}_3$  exists as a dimer ( $\text{Al}_2\text{Cl}_6$ ). It is a strong Lewis acid as it has an incomplete octet and has a tendency to gain electrons.  $\text{AlCl}_3$  undergoes hydrolysis easily and forms an acidic solution.  
$$\text{AlCl}_3 + 3\text{H}_2\text{O} \rightarrow \text{Al}(\text{OH})_3 + 3\text{HCl}$$
  
Option (c) is true that  $\text{AlCl}_3$  sublimes at  $100^\circ\text{C}$  under vacuum.  
 $\text{AlCl}_3$  is a **Lewis acid**.  
11. (b) Graphite shows moderate electrical conductivity due to the presence of unpaired or free fourth valence electron on each carbon atom.  
12. (b) Bleaching action of chlorine is only in presence of moisture where nascent oxygen is displaced from  $\text{H}_2\text{O}$ .  
$$\text{Cl}_2 + \text{H}_2\text{O} \rightarrow \text{HCl} + \text{HClO} \text{ (unstable)}$$
  
$$\text{HClO} \rightarrow \text{HCl} + |\text{O}|$$
  
13. (a) Only nitrates of heavy metals and lithium decompose on heating to produce  $\text{NO}_2$ .  
14. (c)  $\text{SO}_2$  is highly soluble in water and therefore cannot be collected over water.  
15. (b)  $2\text{HgO} \xrightarrow{\Delta} 2\text{Hg} + \text{O}_2$
16. (b) 
- The structure clearly shows the presence of covalent and co-ordinate bonds.
17. (d)  $\text{NO}_2$  is reddish brown coloured gas. Rest of the oxides are colourless.  
18. (a) Least basic trihalogen of nitrogen is  $\text{NF}_3$  because of the highest electronegativity of fluorine.  
19. (b) Chlorine is stronger oxidising agent than bromine therefore, chlorine water will liberate bromine from KBr solution.  
$$2\text{KBr} + \text{Cl}_2 \rightarrow 2\text{KCl} + \text{Br}_2$$

20. (d) In  $S_2O_7^{2-}$  there is an S–O–S bond unlike in other. So S–S bond is absent as can be seen from the structure drawn.

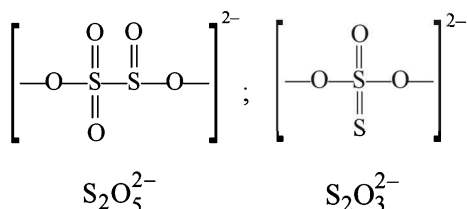
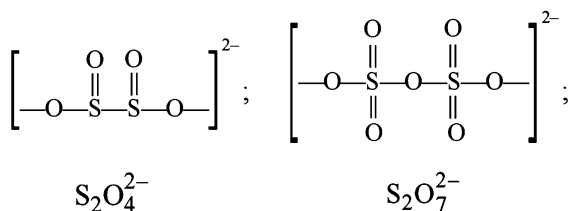

21. (c) In  $P_4O_{10}$ , each P atom is linked to 4 oxygen atoms as can be confirmed by its structure. It is linked to three oxygen atoms by single bond and with one oxygen atom by double bond. [For structure refer to Q. 11 of Section A]

22. (b) HBr is not prepared by heating NaBr with conc.  $H_2SO_4$  because HBr is a strong reducing agent and reduce  $H_2SO_4$  to  $SO_2$  and is itself oxidised to bromine.
- $$\text{NaBr} + \text{H}_2\text{SO}_4 \longrightarrow \text{NaHSO}_4 + \text{HBr}$$
- $$\text{H}_2\text{SO}_4 + 2\text{HBr} \longrightarrow \text{SO}_2 + \text{Br}_2 + 2\text{H}_2\text{O}$$

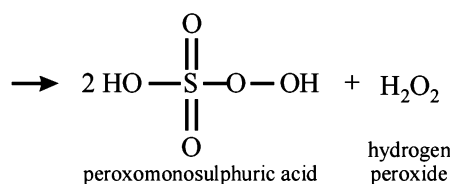
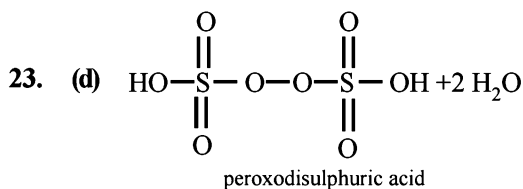

24. (c)  $\text{CsBr}_3$  may be represented as  $\text{Cs}^+\text{Br}_3^-$

25. (c)  $\text{KF} + \text{HF} \rightarrow \text{KHF}_2 \rightleftharpoons \text{K}^+ + (\text{HF}_2)^-$

26. (b)  $\text{Na}_2\text{SO}_3 + \text{S} \xrightarrow[\text{medium}]{\text{In alkaline}} \text{Na}_2\text{S}_2\text{O}_3$

27. (d) Due to inert pair effect.

28. (a) CO is an example of neutral oxide.

29. (b) The species called as pseudohalide ions are these are monovalent and made by electronegative atoms. They possess properties similar to halide ion. The corresponding dimers of these pseudohalide ions are called pseudohalogens.  $\text{RCOO}^-$  is **not** pseudohalide.

30. (c)  $\text{Ca}_3\text{P}_2 + 6\text{H}_2\text{O} \rightarrow 3\text{Ca}(\text{OH})_2 + 2\text{PH}_3$ ; i.e 2 moles of phosphine are produced.

31. (d)  $(\text{NH}_4)_2\text{Cr}_2\text{O}_7 \rightarrow \text{N}_2 + \text{Cr}_2\text{O}_3 + 4\text{H}_2\text{O}$

32. (c)  $\text{Al}_2\text{O}_3$  is electrolyte, while  $\text{Na}_3\text{AlF}_6$  is used to decrease the melting point of  $\text{Al}_2\text{O}_3$  and to increase the conductivity.

33. (b) In  $\text{BCl}_3$ ,  $H = \frac{1}{2}(3 + 3 + 0 - 0) = 3$ ;  $sp^2$  hybridization

(bond angle =  $120^\circ$ ) similarly  $\text{PCl}_3$ ,  $\text{AsCl}_3$  and  $\text{BiCl}_3$  are found to have  $sp^3$  hybridized central atom with one lone pair of electrons on the central atom. The bond angle  $\leq 109^\circ 28'$ , since the central atoms belong to the same group, the bond angle of the chlorides decreases as we go down the group. Thus the order of bond angle is,  $\text{BCl}_3 > \text{PCl}_3 > \text{AsCl}_3 > \text{BiCl}_3$ .

34. (c) Cryolite reduces the melting temperature.

35. (c) In cyclic metaphosphoric acid number of P–O–P bonds is three.

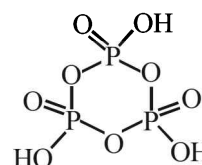

36. (c)  $\text{NH}_3$  does not react with CaO while other reacts with  $\text{NH}_3$

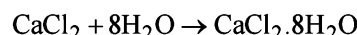
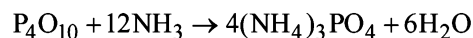
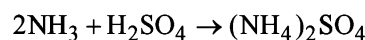

37. (d) In sulphur trioxide trimer  $\text{S}_3\text{O}_9$  (also called  $\gamma$ -sulphur trioxide) two sulphur atoms are linked to each other via O atoms, hence there is no S–S bond.

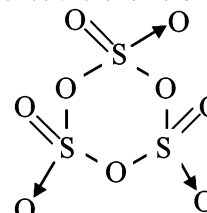

38. (c)  $2\text{Ca}^{2+} + \text{Na}_2[\text{Na}_4(\text{PO}_3)_6]$

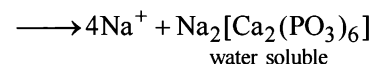

39. (a) The structure of  $\text{H}_3\text{PO}_3$  is as follows: There are only two –OH groups and hence **dibasic**. The oxidation number of P in this acid is +3. Whereas P can have +5 oxidation state also. Therefore,  $\text{H}_3\text{PO}_3$  can be oxidised which means  $\text{H}_3\text{PO}_3$  is a **reducing agent**.

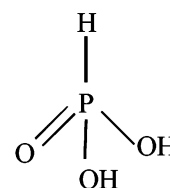

40. (a) The central boron atom in boric acid,  $\text{H}_3\text{BO}_3$  is electron-deficient.

**NOTE : Boric acid is a Lewis acid with one p-orbital vacant. There is no d-orbital of suitable energy in boron atom. So, it can accommodate only**



one additional electron pair in its outermost shell.

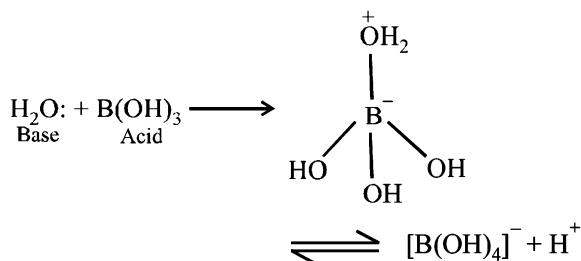

41. (c) TIPS/FORMULAE:

It appears at the first sight that  $\text{Me}_2\text{SiCl}_2$  on hydrolysis will produce  $\text{Me}_2\text{Si(OH)}_2$  which ultimately upon loss of water, will form  $\text{Me}_2\text{Si=O}$ .

But silicon atom, because of its very large size in comparison to oxygen, is unable to form  $\pi$ -bond. Thus, the product of hydrolysis is polymeric in nature.

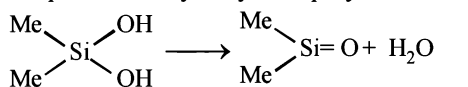

↓ Polymerisation

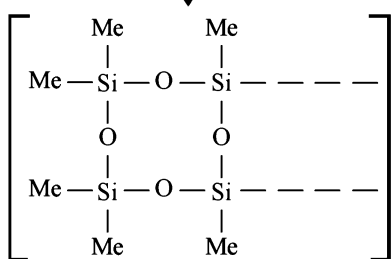

42. (b) In  $\text{XeOF}_4$ , Xenon is  $sp^3d^2$  hybridised and has one lone pair.  
 43. (c) Among oxyacids of sulphur, only Caro's acid ( $\text{H}_2\text{SO}_5$ ) and Marshall's acid ( $\text{H}_2\text{S}_2\text{O}_8$ ) have the O—O linkage.  
 44. (b) Tin can be extracted only by carbon reduction method, while lead can be extracted by self as well as carbon reduction method.

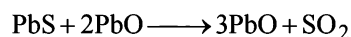
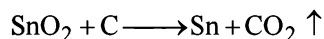

45. (b) Two dimensional sheet structures are formed when three oxygen atoms of each  $[\text{SiO}_4]^{4-}$  tetrahedral are shared.  
 46. (c) The ignition temperature of black phosphorus is highest among all its allotropes, hence is most stable.  
 47. (c) In  $\text{KMnO}_4$  manganese is already present in its highest possible oxidation state i.e. +7. So no further oxidation is possible.

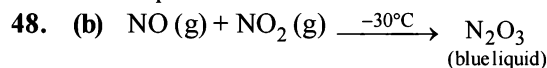

49. (b)  $\text{PbO}_2$  is a powerful oxidizing agent and liberate  $\text{O}_2$  when treated with acids.



50. (b) *cis*-1,2-diol forms chelated complex ion with the product,  $[\text{B(OH)}_4]^-$  causing the reaction to proceed in forward direction.

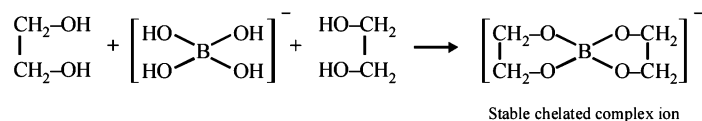

51. (d) In  $\text{P}_4$ , the P—P linkage is formed by  $sp^3-sp^3$  hybridised orbital overlapping. So the percentage of  $\pi$ -character will be 75%.

52. (b) The following reaction occurs

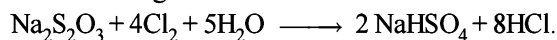

53. (b)  $\text{P}_4 + 3\text{O}_2 \xrightarrow{\text{in presence of N}_2} \text{P}_4\text{O}_6$

Here  $\text{N}_2$  acts as a diluent and thus retards further oxidation. Reaction of  $\text{P}_4$  under other three conditions.

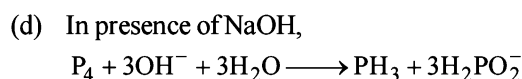
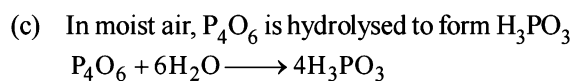
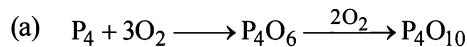

54. (d)  $\text{Ba(N}_3)_2 \longrightarrow \text{Ba} + 3\text{N}_2$

55. (b)  $\text{HNO}_3$ ,  $\text{NO}$ ,  $\text{N}_2$ ,  $\text{NH}_4\text{Cl}$

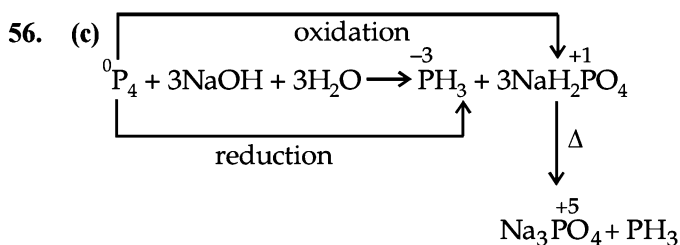

57. (d)  $\text{XeO}_2\text{F}_2$  has trigonal bipyramidal geometry, due to presence of lone pair of electrons on equatorial position, its shape is *see-saw*.

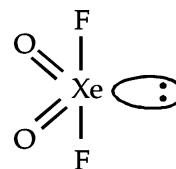

58. (b) The slow decomposition of  $\text{HNO}_3$  is represented by the eqn.

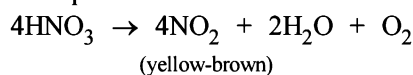

59. (a)  $\text{P}_4 + 8\text{SOCl}_2 \longrightarrow 4\text{PCl}_3 + 4\text{SO}_2 + 2\text{S}_2\text{Cl}_2$   
white phosphorus

60. (c)

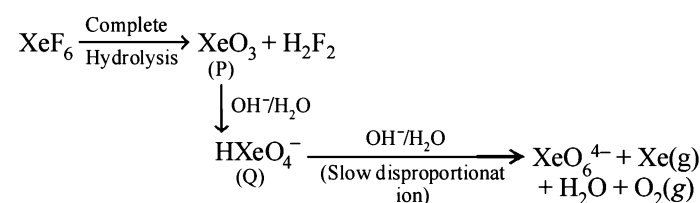

61. (b) Atomic radii increases on moving down a group. However due to poor shielding effect of  $d$  orbit, atomic radius of Ga is smaller than Al (**anomaly**). Thus the correct order is  $\text{Ga} < \text{Al} < \text{In} < \text{Tl}$

62. (a)

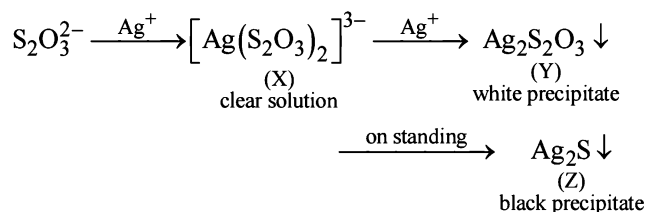

So, X, Y and Z are  $[\text{Ag}(\text{S}_2\text{O}_3)_2]^{3-}$ ,  $\text{Ag}_2\text{S}_2\text{O}_3$  and  $\text{Ag}_2\text{S}$  respectively.

#### D. MCQs with One or More Than One Correct

1. (a, b) Because of high melting point ( $2050^\circ\text{C}$ ), pure alumina cannot be electrolysed. Hence a mixture of alumina, cryolite (m.p.  $1000^\circ\text{C}$ ) and calcium fluoride (to lower the temperature of the melt) is electrolysed at about  $900^\circ\text{C}$ .

**NOTE :** The function of cryolite is to increase the electrical conductivity of the electrolyte, and to lower the temperature of the melt.

2. (a, d)  $\text{NH}_4\text{NO}_3 \longrightarrow \text{N}_2\text{O} + 2\text{H}_2\text{O}$   
 $\text{NH}_2\text{OH} \cdot \text{HCl} + \text{NaNO}_2 \longrightarrow \text{N}_2\text{O} + \text{NaCl} + 2\text{H}_2\text{O}$
3. (a, d)  $\text{NH}_3$  and  $\text{CF}_2\text{Cl}_2$  (freon-12) are used as refrigerants.
4. (b, c) To make the fused mixture very conducting and to reduce the temperature of the melt.
5. (b) Silicon is used in solar cells.
6. (a, b, d) Sodium nitrate on decomposition upto  $500^\circ\text{C}$  gives  $\text{NaNO}_2$  and oxygen.

$$2\text{NaNO}_3 \xrightarrow{\Delta} 2\text{NaNO}_2 + \text{O}_2 \uparrow$$

While at higher temperature (i.e. above to  $800^\circ\text{C}$ ),  $\text{NaNO}_2$  further decomposes into  $\text{Na}_2\text{O}$ ,  $\text{N}_2$  and  $\text{O}_2$ .

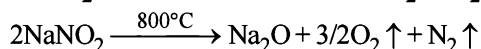

7. (a, c, d) The four atoms in a  $\text{P}_4$  molecule are situated at the corners of a tetrahedron. There are six P - P single bonds with PPP bond angle equal to  $60^\circ$ . Each phosphorus has a lone pair of electrons.
8. (c)  $2\text{NH}_3 + \text{OCI}^- \rightarrow \text{NH}_2\text{NH}_2 + \text{H}_2\text{O} + \text{Cl}^-$
9. (a, b) When ammonium salt  $\text{NH}_4\text{NO}_3$  or  $\text{NH}_4\text{NO}_2$  (ammonium salts are colourless) is boiled with excess of  $\text{NaOH}$ , ammonia ( $\text{NH}_3$ ) gas is evolved as follows:  
 $\text{NH}_4\text{NO}_2 + \text{NaOH} \longrightarrow \text{NaNO}_2 + \text{NH}_3 + \text{H}_2\text{O}$   
 $\text{NH}_4\text{NO}_3 + \text{NaOH} \longrightarrow \text{NaNO}_3 + \text{NH}_3 + \text{H}_2\text{O}$   
 The  $\text{NH}_3$  gas evolved is non-flammable gas.  
 When the gas evolution ceases we are left with  $\text{NaNO}_2$  or  $\text{NaNO}_3$  in solution.  
 These salts get reduced when Zn is added to this solution containing salt ( $\text{NaNO}_2$  or  $\text{NaNO}_3$ ) and excess  $\text{NaOH}$  and  $\text{NH}_3$  gas is evolve.

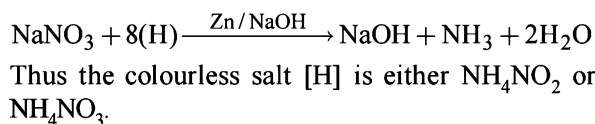
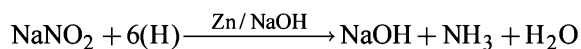

Thus (a) and (b) are correct answers.

[NOTE :  $\text{NaCl}$  formed has no reaction with  $\text{NaOH}$ ]

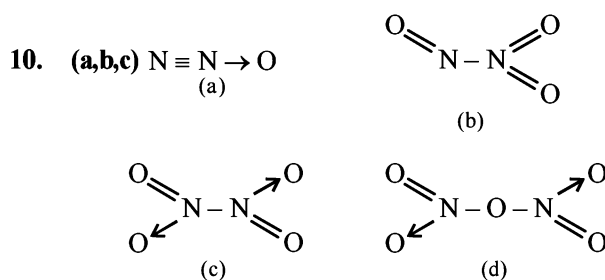

11. (a, c, d)

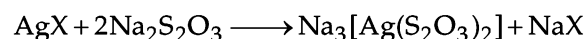
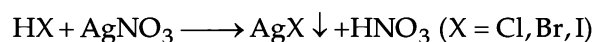

12. (b, d)

- (a) Diamond is harder than graphite.
- (b) Graphite is good conductor of electricity as each carbon is attached to three C-atoms leaving one valency free, which is responsible for electrical conduction, while in diamond, all the four valencies of carbon are satisfied, hence insulator.
- (c) Diamond is better thermal conductor than graphite. Whereas electrical conduction is due to availability of free electrons; thermal conduction is due to transfer of thermal vibrations from atom to atom. A compact and precisely aligned crystal like diamond thus facilitates fast movement of heat.
- (d) In graphite, C - C bond acquires double bond character, hence higher bond order than in diamond.

13. (a, c, d)

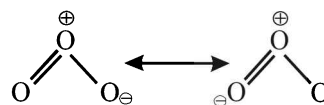

Ozone is diamagnetic in nature (due to presence of paired electron) and both the O - O bond length are equal. It has a bent structure.

14. (a, b, d) Balanced chemical equation is

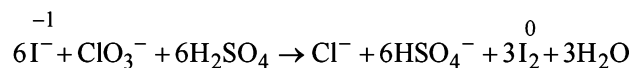

15. (b, d)  $\text{H}_3\text{BO}_3$  does not undergo self ionization. However, it acts as a weak acid in water (hence it is a weak electrolyte in water).

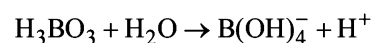

Addition of *cis*-diols (e.g., ethylene glycol) to aqueous solution of orthoboric acid leads to complex formation, thus acidity of aqueous solution of orthoboric acid is increased.

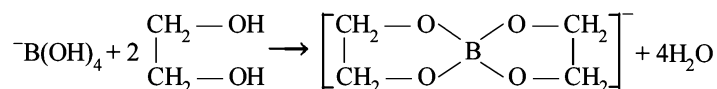

It arranges to planner sheets due to H-bonding.

16. (b, c)

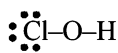

(i)

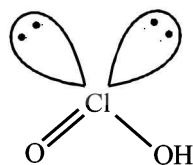

(ii)

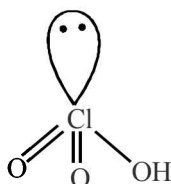

(iii)

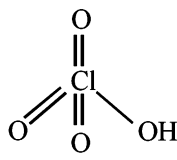

(iv)

Number of Cl=O bonds in (ii) and (iii) together is 3  
Number of lone pairs on Cl in (ii) and (iii) together is 3  
Hybridisation of Cl in all the four is  $sp^3$   
Strongest acid is  $\text{HClO}_4$  (iv)

17. (b)  $(\text{CH}_3)_2\text{SiCl}_2$  form linear polymer on hydrolysis and  $(\text{CH}_3)_3\text{SiCl}$  is a chain terminator.

18. (a, c, d) Structure of borax

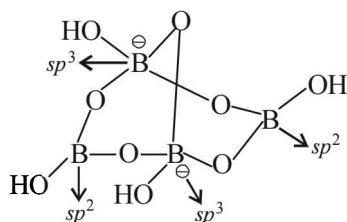

Correct formula of borax is  $\text{Na}_2[\text{B}_4\text{O}_5(\text{OH})_4] \cdot 8\text{H}_2\text{O}$

- (A) Borax has tetranuclear.  $[\text{B}_4\text{O}_5(\text{OH})_4]^{2-}$  unit  
(B) Only two 'B' atom lie in same plane  
(C) two Boron are  $sp^2$  and two are  $sp^3$  hybridised.  
(D) one terminal hydroxide per boron atom.

19. (b, d)

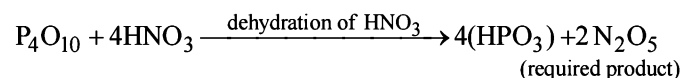

- (A)  $\text{P}_4 + 20\text{HNO}_3 \longrightarrow 4\text{H}_3\text{PO}_4 + 20\text{NO}_2\uparrow + 4\text{H}_2\text{O}$   
(B)  $\text{N}_2\text{O}_5$  is diamagnetic in nature

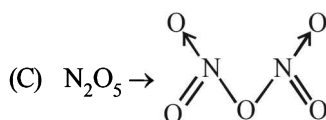

$\text{N}_2\text{O}_5$  contains one N—O—N bond not N—N bond.

- (D)  $\text{Na} + \text{N}_2\text{O}_5 \rightarrow \text{NaNO}_3 + \text{NO}_2\uparrow$   
(Brown gas)

### E. Subjective Problems

- (i) HBr is a reducing agent and it reduces  $\text{H}_2\text{SO}_4$  to  $\text{SO}_2$ .  
(ii) Acids turn blue litmus red, so HClO also turns blue litmus red. The colour of litmus is decolourised because HClO is also a strong oxidising agent.
- (i)  $\text{Al}_2\text{O}_3 + 3\text{C} + 3\text{Cl}_2 \longrightarrow 2\text{AlCl}_3 + 3\text{CO}$   
Alumina Aluminium chloride  
(ii)  $\text{Ca(OH)}_2 + \text{Cl}_2 \longrightarrow \text{CaOCl}_2 + \text{H}_2\text{O}$   
Slaked lime bleaching powder  
(iii)  $\text{SnO}_2 + 2\text{C} \longrightarrow \text{Sn} + 2\text{CO}$   
Cassiterite Tin  
(iv)  $2\text{NaCl} + \text{MnO}_2 + 2\text{H}_2\text{SO}_4 \xrightarrow{\Delta} \text{Na}_2\text{SO}_4 + \text{MnSO}_4 + 2\text{H}_2\text{O} + \text{Cl}_2$   
Sodium chloride Nitric acid Nitric oxide  
(v)  $3\text{Cu} + 8\text{HNO}_3 \longrightarrow 2\text{NO} + 3\text{Cu(NO}_3)_2 + 4\text{H}_2\text{O}$   
Nitric acid Nitric oxide
- (i)  $\text{Sn} + 4\text{HNO}_3 \longrightarrow \text{H}_2\text{SnO}_3 + 4\text{NO}_2 + \text{H}_2\text{O}$   
Metastannic acid  
(ii)  $2\text{Al} + 2\text{NaOH} + 2\text{H}_2\text{O} \longrightarrow 2\text{NaAlO}_2 + 3\text{H}_2$   
Sod. aluminate
- (i)  $\text{HO}-\overset{\text{H}}{\underset{\text{O}}{\text{P}}}-\text{OH}$  (ii)  $\text{O}=\overset{\text{OH}}{\text{P}}-\text{O}-\overset{\text{OH}}{\text{P}}=\text{O}$
- (i)  $\text{HCO}_3^- + \text{Al}^{3+} \rightarrow \text{Al(OH)}_3 + \text{CO}_3^{2-}$   
(ii)  $\text{AlBr}_3 + \text{K}_2\text{Cr}_2\text{O}_7 + \text{H}_3\text{PO}_4 \rightarrow \text{K}_3\text{PO}_4 + \text{AlPO}_4 + \text{H}_2\text{O} + \text{Br}_2 + \text{Cr}^{3+}$
- (i) Carbon exists in various allotropic forms like diamond, graphite, coal, etc. Diamond consists of a three-dimensional structure of  $sp^3$  hybridised carbon atoms bonded through very strong covalent bonds. It makes it hard and useful as an abrasive.  
Graphite, on the other hand, is made up of a two dimensional sheet like structure made of  $sp^2$  hybridised carbon atoms. These layers of carbon atoms are held together by relatively weak van der Waal's forces and can, therefore, slip over one another imparting lubricating properties to graphite.  
(ii) Sulphur consists of  $\text{S}_8$  rings held together by weak van der Waal's forces. As sulphur melts at  $119^\circ\text{C}$ , these van der Waal's forces are overcome and  $\text{S}_8$  rings slip and roll over one another giving rise to a clear mobile liquid. Above  $160^\circ\text{C}$ , the  $\text{S}_8$  rings begin to open up and form long chains which gets tangled with each other, thereby gradually increasing the viscosity.  
(iii) **NOTE** : HI cannot be prepared by heating hydrogen iodide with conc.  $\text{H}_2\text{SO}_4$  because it is a strong reducing agent and reduces  $\text{H}_2\text{SO}_4$  to  $\text{SO}_2$  and is itself oxidised to iodine.

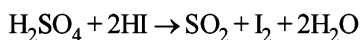

Hence HI is prepared by heating iodides with conc. phosphoric acid.

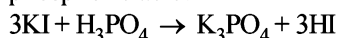

- (iv) In  $\text{H}_3\text{PO}_4$  and  $\text{H}_3\text{PO}_3$  the P atom is attached to 3 and 2 OH groups respectively. The H atom of these P–OH bonds are ionisable. This clearly shows that  $\text{H}_3\text{PO}_4$  is tribasic and  $\text{H}_3\text{PO}_3$  is dibasic.
- (v) Liquor ammonia possesses high vapour pressure at room temperature and thus before opening a bottle of liquor ammonia, it should be cooled to lower the pressure of  $\text{NH}_3$  inside the bottle, otherwise  $\text{NH}_3$  will bump out of the bottle.
- (vi) Solid  $\text{CO}_2$  is technically known as **dry ice** because it sublimates without leaving any stain on surface.
- (vii) Anhydrous HCl, being a non-polar covalent compound, is a bad conductor however an aqueous solution of HCl is ionised (Fajan's rule) to give  $\text{H}^+$  and  $\text{Cl}^-$  ions and is a good conductor.
- (viii) In graphite, out of four valence electrons, only three form covalent bonds ( $sp^2$  hybridisation) with three other carbon atoms. This forms hexagonal rings as sheets of one atom thickness. These sheets are held together by weak attractive forces. One electron of each carbon atom is free and this enables these thin sheets to slide over one another. For this reason graphite is a soft material with lubricating properties.
- (ix) The standard reduction potential of fluorine is highest and thus it cannot be oxidized by any reagent.

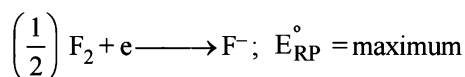

- (x) The mixture of  $\text{N}_2\text{H}_4$  and  $\text{H}_2\text{O}_2$  (in presence of Cu(II) catalyst) is used as a rocket propellant because the reaction is highly exothermic and large volume of gases are evolved, which can propel a rocket.

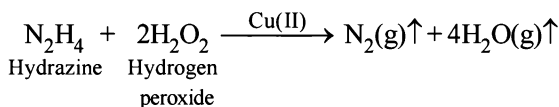

- (xi) Orthophosphorus acid is a dibasic acid as it has 2–OH groups in its formula :

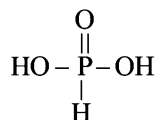

- (xii) In  $\text{MgCl}_2$ , Mg is  $sp$  hybridised while in  $\text{SnCl}_2$ , Sn is  $sp^2$  hybridised (hence the molecule is angular).
- (xiii) **NOTE** : Oxygen is the 2nd most electronegative element after the fluorine and thus invariably show negative oxidation state. Further more, it has  $2s^2 2p^4$  configuration and thus requires only two electrons to complete its octet to show  $-2$  oxidation state. Although sulphur also possess  $ns^2 np^4$  configuration but due to availability of d-orbitals in their outer most shell  $-2, +2, +4, +6$

oxidation state are also shown. Oxygen, however, shows only  $-2$  oxidation state due to non-availability of d-orbitals in its outermost shell.

- (xiv) **NOTE** :  $\text{H}_3\text{PO}_3$  is a dibasic acid because it contains two OH groups in its molecule. In the two P–OH bonds, the hydrogen is ionisable. [For structure see part (xi)]
- (xv) **NOTE** : As compared to P, N atom has higher electronegativity and small size and shows H-bonding. Thus ammonia molecule show association where as phosphine does not.
- (xvi) It is due to self ionization of  $\text{NH}_3$ , the reaction is



Thus on addition of  $\text{NH}_4\text{Cl}$  the concentration of  $\text{NH}_4^+$  radical increases and therefore  $\text{NH}_4\text{Cl}$  acts as an acid in liquid  $\text{NH}_3$ .

- (xvii) In excess of NaOH the hydroxide of Al becomes soluble due to the formation of meta-aluminate.
- (xviii) The repulsive forces between fluorine atoms are high due to its small size and high electronegativity. It makes dissociation of F–F bond easy. So bond dissociation energy of  $\text{F}_2$  is less than  $\text{Cl}_2$
- (xix) The reducing nature of  $\text{SO}_2$  is represented as

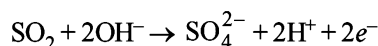

Hence with the increase of  $\text{OH}^-$  (alkalinity) the forward reaction is favoured.

- (xx) Nitrogen and fluorine both are small and have high electron density, they repel the bonded pair of electrons leading to larger bond length than expected.
- (xxi)  $\text{N}^{3-}$  being smaller in size and high charge present on it make it more susceptible to hydrolysis :

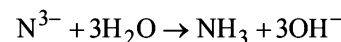

$\text{Cl}^-$  being a weak conjugate base does not undergo hydrolysis.  $\text{MgCl}_2$  is stronger electrolyte and so it is not hydrolysed

- (xxii) In  $(\text{SiH}_3)_3\text{N}$ , lone pair of electrons on nitrogen is involved in  $p\pi-d\pi$  back bonding, while in  $(\text{CH}_3)_3\text{N}$  no such  $p\pi-d\pi$  back bonding is possible because of absence of d orbitals in carbon so  $(\text{CH}_3)_3\text{N}$  is more basic than  $(\text{SiH}_3)_3\text{N}$ .
7. (i) Phosphine gas ( $\text{PH}_3$ ) is evolved when white phosphorous is boiled with aqueous NaOH or alcoholic solution of potassium hydroxide.
- $$\text{P}_4 + 3\text{NaOH} + 3\text{H}_2\text{O} \rightarrow \text{NaH}_2\text{PO}_2 + \text{PH}_3\uparrow$$
- Sod. Hypophosphite
- (ii) This is a method used to prepare  $\text{I}_2$ .
- $$5\text{NaHSO}_3 + 2\text{NaIO}_3 \rightarrow 3\text{NaHSO}_4 + 2\text{Na}_2\text{SO}_4 + \text{I}_2 + \text{H}_2\text{O}$$
- (iii)  $4\text{Sn} + 10\text{HNO}_3 \rightarrow 4\text{Sn}(\text{NO}_3)_2 + \text{NH}_4\text{NO}_3 + 3\text{H}_2\text{O}$   
(dilute)

## The p-Block Elements

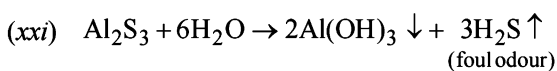
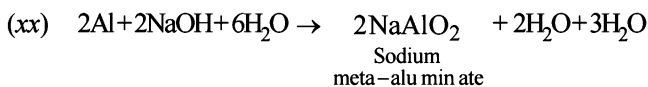
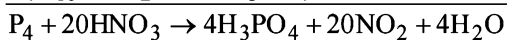
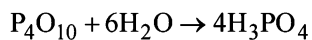
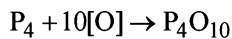
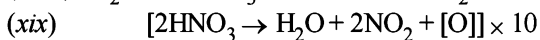
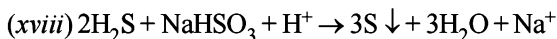
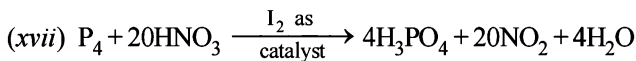
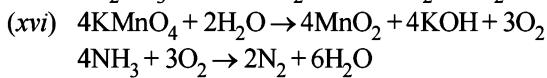
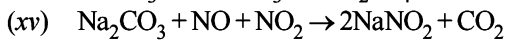
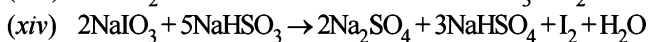
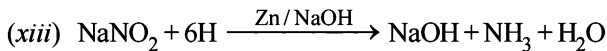
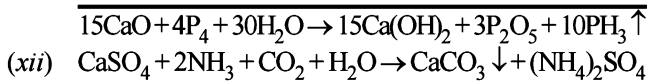
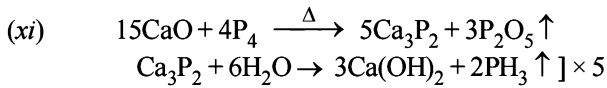
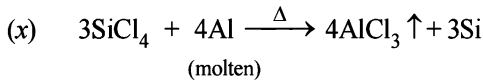
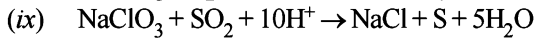
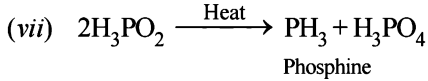
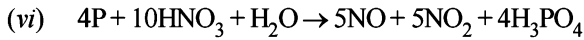
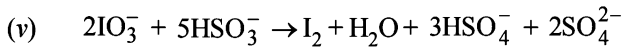
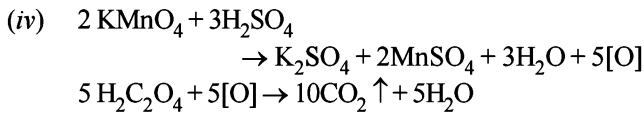

Foul odour, on damping of  $\text{Al}_2\text{S}_3$  is due to formation of  $\text{H}_2\text{S}$  gas, which smells like rotten eggs.

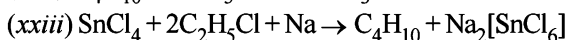

8. By boiling  $\text{Na}_2\text{SO}_3$  solution with powder of sulphur in absence of air sodium thiosulphate is prepared. Unreacted S is removed, filtrate is evaporated to give crystals of sod. thiosulphate.

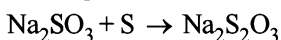

9. Extraction of aluminium from bauxite :

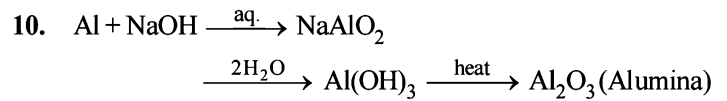
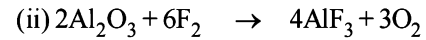
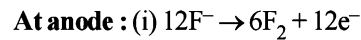
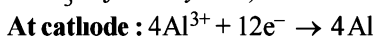

11.  $\text{N}_2\text{O}$  has two principal resonance structures :

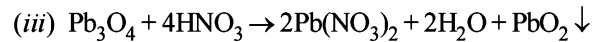
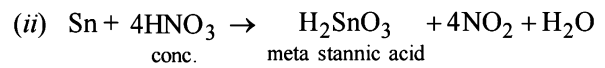
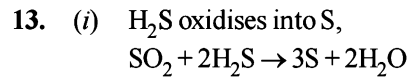
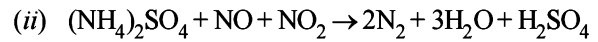
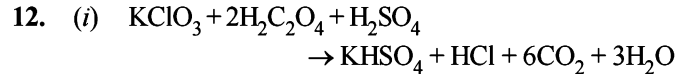
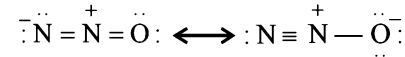

14. (i)  $\text{HI} < \text{HBr} < \text{HCl} < \text{HF}$

The strength of H-X bond decreases from HF to HI. The larger is H-X bond length, lower is the bond energy, lesser is the bond strength.

- (ii)  $\text{HOCl} < \text{HOClO} < \text{HOClO}_2 < \text{HOClO}_3$

As the number of oxygen atoms increase, the -ve charge dispersal becomes more and more from Cl atom due to more electronegativity of oxygen atom and thus lesser is the charge on Cl atom, more will be its stability.

- (iii)  $\text{SiO}_2 < \text{CO}_2 < \text{N}_2\text{O}_5 < \text{SO}_3$ .

Among oxides of the non-metals, the acidic strength increases with oxidation state. Hence  $\text{SO}_3$  (O.S. of S = +6) is most acidic followed by  $\text{N}_2\text{O}_5$  (O.S. of N = +5) and  $\text{CO}_2$  and  $\text{SiO}_2$  (O.S. of C and Si = +4). Further  $\text{CO}_2$  is more acidic than  $\text{SiO}_2$  because of small size of C-atom.

- (iv) Since carbon has no d-orbital, it cannot extend its coordination number beyond four, its halides are not attacked (hydrolysed) by water. On the other hand, silicon have vacant d-orbitals to which water molecules can coordinate and hence their halides are hydrolysed by water.

**NOTE :** Increasing order of extent of hydrolysis

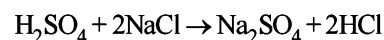
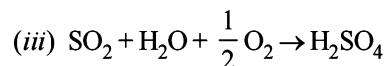
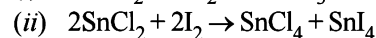
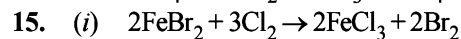

16. The two resonating structures of ozone are :

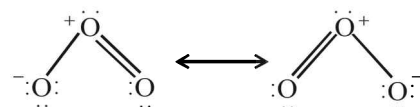

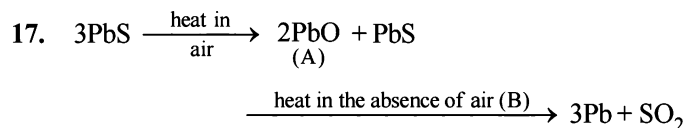

18. (i)  $2\text{P} + 3\text{I}_2 + 6\text{H}_2\text{O} \rightarrow 2\text{H}_3\text{PO}_4 + 6\text{HI}$   
(ii)  $2\text{KNO}_3 + 10\text{K} \rightarrow 6\text{K}_2\text{O} + \text{N}_2$   
(iii)  $2\text{NH}_3 + \text{NaOCl} \rightarrow \text{H}_2\text{N.NH}_2 + \text{NaCl} + \text{H}_2\text{O}$   
Hydrazine  
(iv)  $\text{Sn} + 2\text{KOH} + 4\text{H}_2\text{O} \rightarrow \text{K}_2\text{Sn(OH)}_6 + 2\text{H}_2$

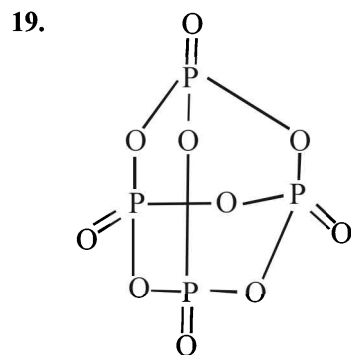

Number of P–O single bonds = 12

Number of P–O double bonds = 4

20. At first  $\text{Bi(NO}_3)_3$  hydrolyses to give nitric acid which, being an oxidising agent, oxidises potassium iodide liberating free iodine responsible for dark brown precipitate. Iodine dissolves in excess of potassium iodide forming soluble  $\text{KI}_3$  imparting yellow colour to solution

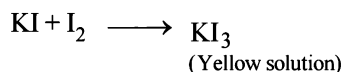
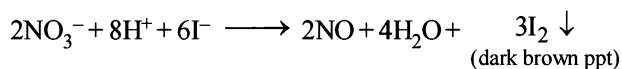
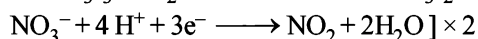
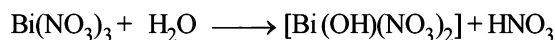

21. (a)  $2\text{KI} + \text{Cl}_2 \rightarrow 2\text{KCl} + \text{I}_2$   
Since  $\text{Cl}_2$  is more powerful oxidising agent than  $\text{I}_2$ ,  $\text{Cl}_2$  is able to displace  $\text{I}^-$  to form  $\text{I}_2$ .

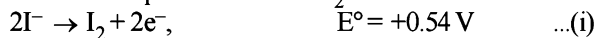

On subtracting eq. (i) from eq. (ii), we get

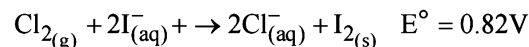

- (b)  $2\text{KClO}_3 + \text{I}_2 \rightarrow 2\text{KIO}_3 + \text{Cl}_2$ .

Here  $\text{ClO}_3^-$  is more powerful oxidising agent than  $\text{IO}_3^-$ , so  $\text{Cl}$  is displaced by  $\text{I}$ .

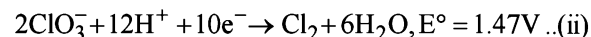
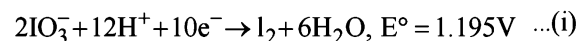

On subtracting eq. (i) from eq. (ii), we get

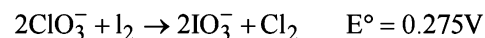

22. The poisonous element M may be As. So on the basis of the given facts,

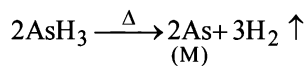
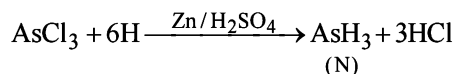

Hence  $\text{M} = \text{As}$ ;  $\text{N} = \text{AsH}_3$

23. In cyclic  $\text{Si}_3\text{O}_9^{6-}$ , three tetrahedra of  $\text{SiO}_4^{2-}$  are joined together sharing two oxygen atoms per tetrahedron.

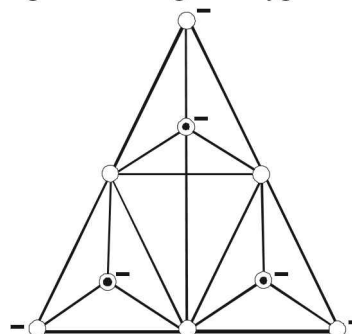

Structure of  $\text{Si}_3\text{O}_9^{6-}$ ;

Dark circle represents Si and

open circle represents oxygen atom/ion

24.  $\text{SO}_2 + \text{PCl}_5 \rightarrow \text{SOCl}_2 + \text{POCl}_3$

Thionyl chloride

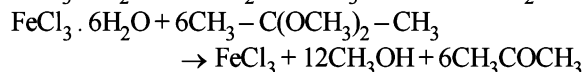
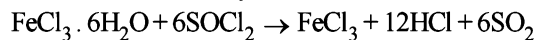

25.  $7\text{H}_3\text{PO}_4 + \text{Ca}_5(\text{PO}_4)_3\text{F} \rightarrow 5\text{Ca}(\text{H}_2\text{PO}_4)_2 + \text{HF}$

Triple superphosphate

26. The reaction is

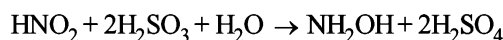

(A) (B) (C) (D)

The structures of A, B, C and D are as follows.

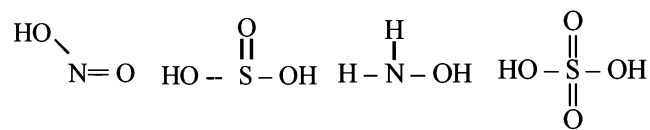

(A) (B) (C) (D)

27. Sulphur trioxide produced in the contact process is absorbed by sulphuric acid forming  $\text{H}_2\text{S}_2\text{O}_7$ . It is not dissolved in water as it gives a dense fog of sulphuric acid particles.

The catalyst used in the contact process is vanadium pentoxide.

28. In such a case

$\text{A} = \text{Ca(OH)}_2$ ,  $\text{B} = \text{NH}_4\text{HCO}_3$ ,  $\text{C} = \text{Na}_2\text{CO}_3$ ,  $\text{D} = \text{NH}_4\text{Cl}$  and  $\text{E} = \text{CaCl}_2$

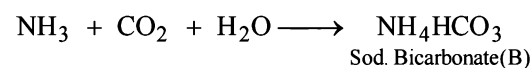
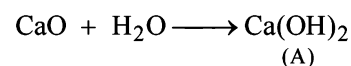

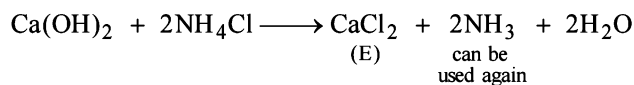
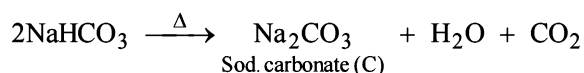
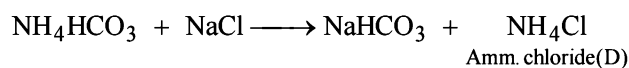

29. More electronegative halogen displaces lesser electronegative halogen from its halide. Thus,

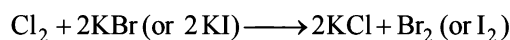

30. TIPS/Formulae :

Use the formula

$H$  (hybridisation),  $H = \frac{1}{2}(V + M - C + A)$  where

$V$  = number of electron in valence shell of central atom

$M$  = number of monovalent atoms surrounding the central atom

$C$  = Charge on cation

$A$  = Charge on anion

$\text{XeF}_2$ :  $H = \frac{1}{2}(8 + 2 - 0 + 0) = 5$  Hence hybridisation is  $sp^3d$ , and thus its structure is linear.

$\text{XeF}_4$ :  $H = \frac{1}{2}(8 + 4 - 0 + 0) = 6$ , Hence hybridisation is  $sp^3d^2$ , and thus its structure is square planar.

$\text{XeO}_2\text{F}_2$ :  $H = \frac{1}{2}(8 + 2 - 0 + 0) = 5$ , Hence hybridisation is  $sp^3d$ , and shape is see saw.

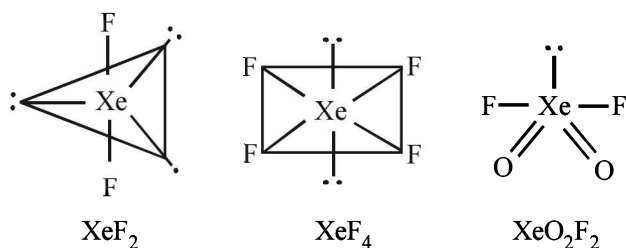

31. Elemental nitrogen exists as a diatomic molecule because nitrogen can form  $p\pi - p\pi$  multiple bonds which is not possible in case of phosphorus due to repulsion between non-bonded electrons of the inner core. There is no such repulsion in case of smaller nitrogen atoms as they have only  $1s^2$  electrons in their inner core.

32. Since  $\text{B}_2\text{O}_3$  is formed by reaction of (Y) with air, (Y) therefore should be  $\text{B}_2\text{H}_6$  in which % of hydrogen is 21.72. The compound (X) on reduction with  $\text{LiAlH}_4$  gives  $\text{B}_2\text{H}_6$ . Thus it is boron trihalide. The reactions are shown as:

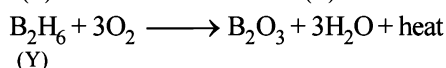
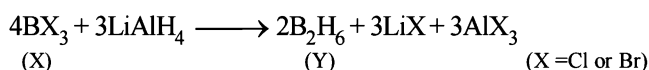

Structure of  $\text{B}_2\text{H}_6$  is as follows:

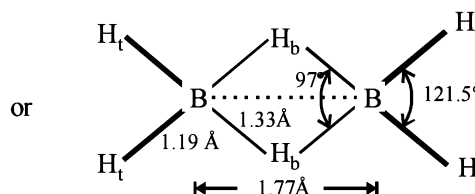
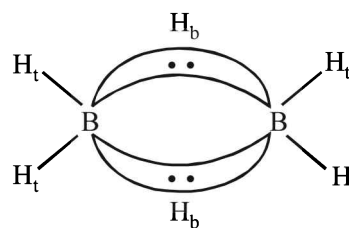

Thus the diborane molecule has **four** two-centre- two -electron bonds ( $2c - 2e$  bonds) also called usual bonds and **two** three-centre-two -electron bonds ( $3c - 2e$ ) also called **banana bonds**. Hydrogen attached to usual and banana bonds are called  $H_t$  (terminal  $H$ ) and  $H_b$  (bridged  $H$ ) respectively.

33. (i)  $\text{SiCl}_4 + 2\text{Mg (or Zn)} \longrightarrow \text{Si} + 2\text{MgCl}_2 \text{ (or ZnCl}_2\text{)}$   
 (ii)  $\text{SiCl}_4 + 2\text{CH}_3\text{MgCl} \longrightarrow (\text{CH}_3)_2\text{SiCl}_2 + 2\text{MgCl}_2$

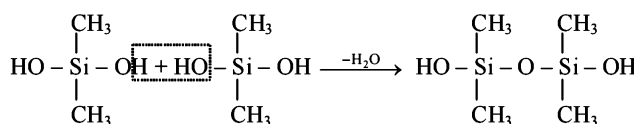
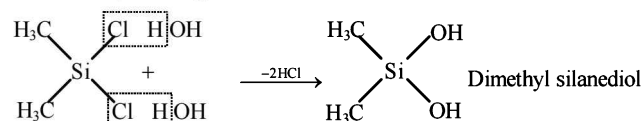

Polymerisation continues on both ends to give linear silicone.

- (iii)  $\text{SiCl}_4 + 2\text{Mg} \longrightarrow \text{Si} + 2\text{MgCl}_2$

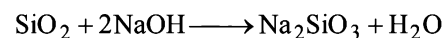
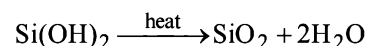
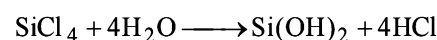

34. (i)  $\text{Al}_4\text{C}_3 + 12\text{H}_2\text{O} \longrightarrow 4\text{Al}(\text{OH})_3 + 3\text{CH}_4 \uparrow$

- (ii)  $\text{CaNCN} + 3\text{H}_2\text{O} \longrightarrow \text{CaCO}_3 \downarrow + 2\text{NH}_3$

Ammonia formed dissolves in water to form  $\text{NH}_4\text{OH}$

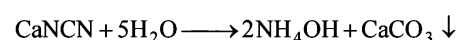

- (iii)  $4\text{BF}_3 + 3\text{H}_2\text{O} \longrightarrow 3\text{HBF}_4 + \text{B}(\text{OH})_3$

- (iv)  $\text{NCl}_3 + 3\text{H}_2\text{O} \longrightarrow \text{NH}_3 + 3\text{HOCl}$

- (v)  $3\text{XeF}_4 + 6\text{H}_2\text{O} \longrightarrow \text{XeO}_3 + 2\text{Xe} + \frac{3}{2}\text{O}_2 + 12\text{HF}$

35. **NOTE** : When hot concentrated  $\text{HCl}$  is added to borax ( $\text{Na}_2\text{B}_4\text{O}_7 \cdot 10\text{H}_2\text{O}$ ) the sparingly soluble  $\text{H}_3\text{BO}_3$  is formed which on subsequent heating gives  $\text{B}_2\text{O}_3$  which is reduced to boron on heating with  $\text{Mg}$ ,  $\text{Na}$  or  $\text{K}$ .

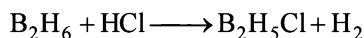
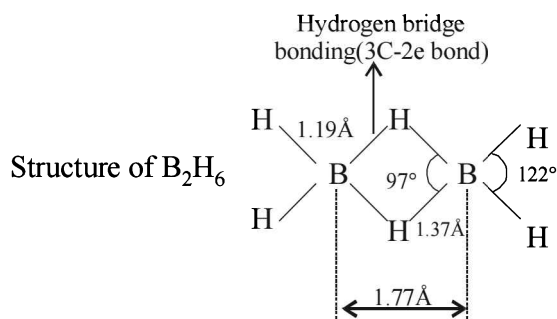
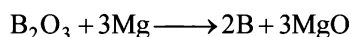
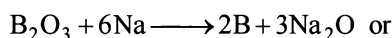
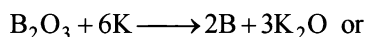
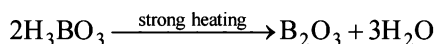
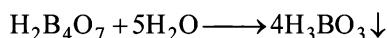
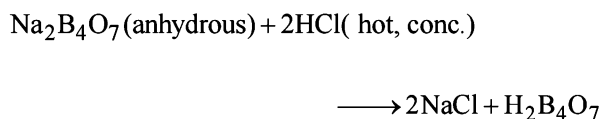

[NOTE : Normally this reaction takes place in the presence of Lewis acid ( $\text{AlCl}_3$ )]

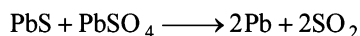
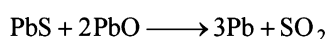
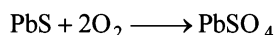
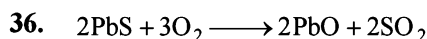

Oxidation number of Pb in litharge ( $\text{PbO}$ ) is +2

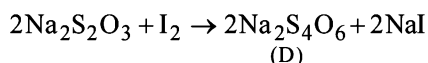
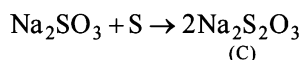
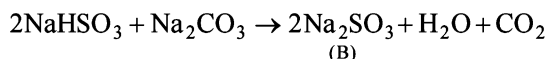
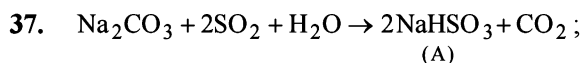

Oxidation states of 'S' are: +4 in (A), (+6) in B and +2 in (C), +2.5 in (D)

38. HF is weakly dissociated, while KF is highly dissociated giving a high concentration of  $\text{F}^-$  which leads to the formation of soluble  $\text{AlF}_6^{3-}$ .

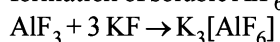

Since  $\text{BF}_3$  is more acidic than  $\text{AlF}_3$ , it pulls out  $\text{F}^-$  from  $\text{AlF}_6^{3-}$  precipitating  $\text{AlF}_3$ .

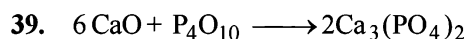
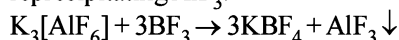

$$\text{Moles of } \text{P}_4\text{O}_{10} = \frac{852}{284} = 3$$

$$\text{Moles of CaO} = 3 \times 6 = 18; \text{ wt. of CaO} = 18 \times 56 = 1008 \text{ g}$$

For structure of  $\text{P}_4\text{O}_{10}$  : See question 20 of this section.

40.  $(\text{CH}_3)_3\text{N}$  and  $(\text{Me}_3\text{Si})_3\text{N}$  are not isostructural, the former is pyramidal while the latter is trigonal planar. Silicon has vacant  $d$  orbitals which can accommodate lone pair of electrons from N (back bonding) leading to planar shape.

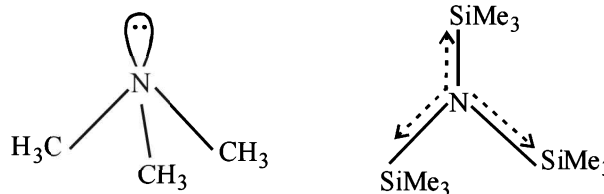

41. A. Conc.  $\text{H}_2\text{SO}_4$

B.  $\text{Br}_2$

C.  $\text{NO}_2^+$

D.

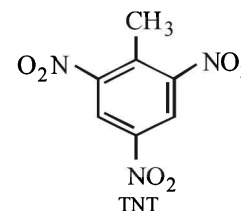

Reactions involved are

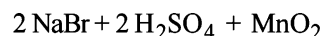

[A]



[B]

Brown fumes  
and pungent smell

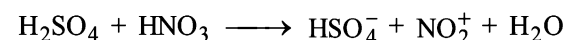

[C]

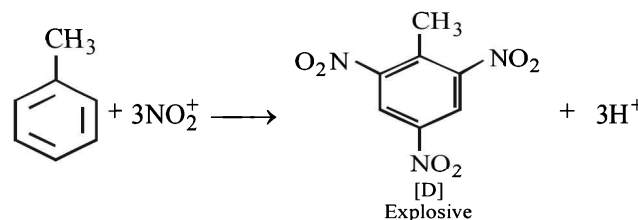

### F. Match the Following

- (A)-(t),  $\text{Pb}(\text{N}_3)_2$  is an explosive  
(B)-(s),  $\text{Al}_2\text{O}_3$  is used to prepare artificial gun  
(C)-(v), Extraction of copper involves self-reduction process.  
(D)-(u),  $\text{Fe}_2\text{O}_3$  is a magnetic material.
- (A)-(q),  $\text{Bi}^{3+}$  hydrolyses to yield  $\text{BiO}^+$  ion  
(B)-(s),  $\text{AlO}_2^-$  on dilution yields a white ppt. of  $\text{Al}(\text{OH})_3$   
(C)-(p), When heated  $(\text{SiO}_4)^{4-}$  changes to  $(\text{Si}_2\text{O}_7)^{6-}$   
(D)-(r), When acidified  $(\text{B}_4\text{O}_7)^{2-}$  gives  $\text{B}(\text{OH})_3$  (or  $\text{H}_3\text{BO}_3$ )



## The p-Block Elements

3. (A) -p, r, t; (B) -s, t; (C) -p, q, r; (D) -p, r, s

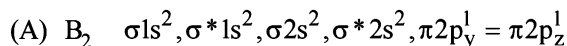

Bond order = 1 Paramagnetic

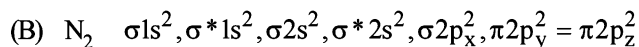

Bond order = 3 Diamagnetic

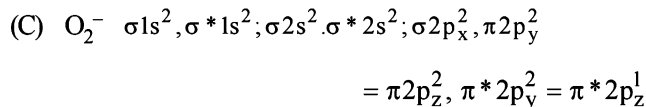

Bond order = 1.5 Paramagnetic

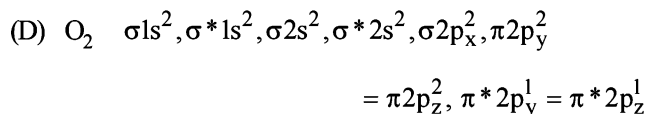

Bond order = 2 Paramagnetic

4. (d) (P)

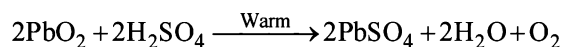

(Q)

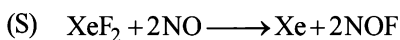
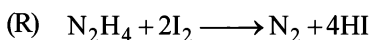
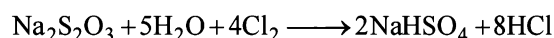

## G. Comprehension Based Questions

- (a) Argon, being a noble gas, will not react with the metals, thus, can be used in arc welding.
- (c) In  $XeO_3$  there are total of 4 electron pairs around central atom. Out of which 3 are bonding electron pair and one is non-bonding electron pair. This combination provides  $sp^3$ -hybridization and pyramidal shape.

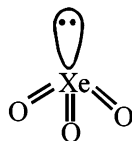

- (a) All xenon fluorides are strongly oxidizing,  $XeF_4$  can act as reducing agent (with  $F_2$ ) as well as oxidizing agent but  $XeF_6$  can only function as an oxidizing agent.

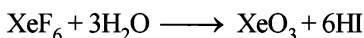
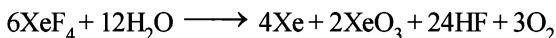

- (c) We know that phosphates have a biological significance in human, therefore statement (a) is not correct. Since nitrates are more soluble in water so they are less abundant in earth's crust where as phosphates are less soluble in water and so they are more abundant in earth's crust. Thus statement (b) is False and statement (c) is correct.

**NOTE :** In nitrates ( $NO_3^-$ ) nitrogen is in + 5 oxidation state which is the highest oxidation state exhibited by

nitrogen. Because of this nitrates can not be oxidized (oxidation means increase in oxidation state). Hence statement (d) is not correct.

The correct answer is (c).

- (c) In case of group 15 (nitrogen group), on moving down the group there occurs a decrease in bond angle of metal hydrides. This decrease in bond angle of metal hydrides of this group may be attributed to the increased p-character in the bond pair which results in more s-character in lone pair orbital.

**NOTE :** The directional character is more for  $sp^3$  hybrid orbital than a s-orbital.

Thus the correct answer is (c).

- (b) The reaction between NaOH and white phosphorus ( $P_4$ ) can be represented as follows:

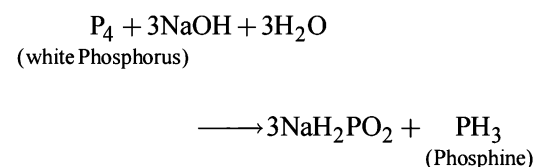

**NOTE :** In this reaction Phosphorus is oxidised as well as reduced so it is a disproportionation reaction.

$\therefore$  The correct answer is (b).

- (a)  $Ca(OCl)Cl \longrightarrow Ca^{2+} + ^-OCl + Cl^-$   
 $^-OCl$  (Hypochlorite ion) is anion of the acid  $HOCl$  which on dehydration gives  $Cl_2O$ .

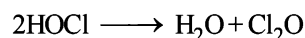

- (c) Number of millimole of hypo =  $0.25 \times 48 = 2 \times$  millimole of  $Cl_2$

$$\therefore \text{Number of millimole of } Cl_2 = \frac{0.25 \times 48}{2} = 6$$

millimole of  $Cl_2 =$  millimole of  $CaOCl_2$

Molarity of bleaching solution

$$= \frac{\text{Millimoles of } CaOCl_2}{\text{Vol. (in mL) of } CaOCl_2} = \frac{6}{25} = 0.24$$

- (a)  $Cl_2 + 2NaOH(\text{dil.}) \xrightarrow{\text{cold}} NaOCl + NaCl + H_2O$   
(P)

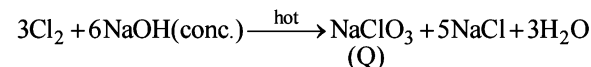

(P) and (Q) are salts of  $HOCl$  and  $HClO_3$  respectively.

- (a)  $SO_2 + Cl_2 \xrightarrow[\text{Catalyst}]{\text{Charcoal}} SO_2Cl_2$   
(R)

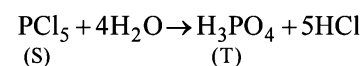
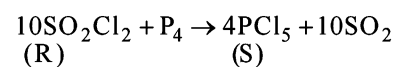

### H. Assertion & Reason Type Questions

- (b) Nitrogen cannot form pentahalides because it cannot expand its octet due to non-availability of d-orbitals. So E is not correct explanation of S.
- (c) F has slightly less electron affinity than chlorine because F has very small atomic size (only two shells). Hence there is a tendency of electron-electron repulsion, which results in less evolution of energy in the formation of  $F^-$  ion. Assertion is correct but reason incorrect.
- (a) Both assertion and reason are correct and reason explains assertion.
- (c)  $SiCl_4$  undergoes hydrolysis due to the presence of empty *d* orbitals in the valence shell of Si, while C has no vacant *d* orbitals to accommodate electron pairs donated by water molecules during hydrolysis.
- (c) Statement-1 is correct but statement-2 incorrect. Orthoboric acid ( $H_3BO_3$ ) is soluble in water and behaves as weak monobasic acid. It does not donate protons like most acids, but rather it accepts  $OH^-$  ions. It is, therefore, Lewis acid, and is better written as  $B(OH)_3$ .  

$$B(OH)_3 + 2H_2O \rightleftharpoons H_3O^+ + [B(OH)_4]^-; pK_a = 9.25$$
- (a) Both statements are true. Boron forms only covalent compounds (bonds) because small sized B ion polarizes the corresponding anion largely.
- (c) **NOTE** : In group 14 elements, the lower (and not higher) oxidation states are more stable for heavier members of

the group due to inert pair effect.

Thus  $Pb^{4+}$  is less stable as compared to  $Sn^{4+}$  (lead is heavier than Tin). Therefore  $Pb^{4+}$  acts as a strong oxidising agent than  $Sn^{4+}$ . Hence statement 1 is false and statement 2 is true. Thus the correct answer is option (c).

### I. Integer Value Correct Type

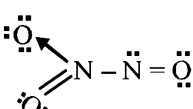
- Coordination number of Al is 6. It exists in *ccp* lattice with 6 coordinate layer structure.
- Total cationic charge = Total anionic charge  
 $2n + 6 + 24 = 36 \Rightarrow n = 3$
- 5  
 $3Br_2 + 3Na_2CO_3 \longrightarrow 5NaBr + NaBrO_3 + 3CO_2$
- 4  
 $PCl_5 + SO_2 \longrightarrow POCl_3 + SOCl_2$   
 $PCl_5 + H_2O \longrightarrow POCl_3 + 2HCl$   
 $PCl_5 + H_2SO_4 \longrightarrow POCl_3 + SO_2Cl_2 + 2HCl$   
 $6PCl_5 + P_4O_{10} \longrightarrow 10POCl_3$
- (8)   
 Number of lone pairs = 8
- (6)  $3B_2H_6 + 18CH_3OH \rightarrow 6B(OCH_3)_3 + 18H_2$

## Section-B JEE Main/AIEEE

- (c) Alum furnishes  $Al^{3+}$  ions which bring about coagulation of negatively charged clay particles, bacteria etc.
- (d) In the formation of  $XeF_2$ ,  $sp^3d$  hybridisation occurs which gives the molecule a trigonal bipyramidal structure.

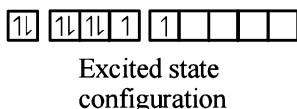
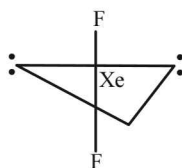
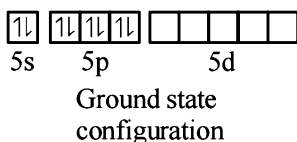

In the formation of  $XeF_4$ ,  $sp^3d^2$  hybridization occurs which gives the molecule an octahedral structure.

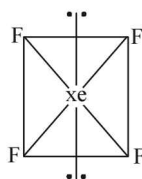
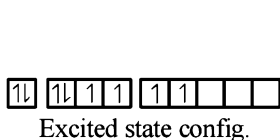

In the formation of  $XeF_6$ ,  $sp^3d^3$  hybridization occurs which gives the molecule a pentagonal bipyramidal structure.

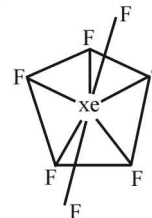

- (a)  ${}^7N = 1s^2 2s^2 2p^3$ ,  ${}^{15}P = 1s^2 2s^2 2p^6 3s^2 3p^3$   
**NOTE** : In phosphorous the 3d-orbitals are available. Hence phosphorous can form pentahalides also but nitrogen can not form pentahalide due to absence of d-orbitals
- (c)
- (d)

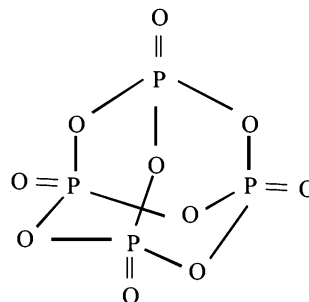

6. (d)  $\text{CaOCl}_2$  — or it can also be written as

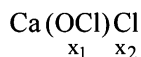

hence oxidation no. of Cl in  $\text{OCl}^-$  is

$$\begin{aligned} -2 + x_2 &= -1 \\ x_2 &= 2 - 1 = +1 \end{aligned}$$

now oxidation no. of another Cl is  $-1$  as it is present as  $\text{Cl}^-$ .

7. (d) On mixing phosphine with chlorine gas  $\text{PCl}_5$  and  $\text{HCl}$  forms. The mixture cools down.

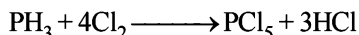

8. (a)  $4\text{HCl} + \text{O}_2 \rightarrow 2\text{Cl}_2 + 2\text{H}_2\text{O}$

air                      cloud of white fumes

9. (c) In graphite, carbon is  $\text{sp}^2$  hybridized. Each carbon is thus linked to three other carbon atoms forming hexagonal rings. Since only three electrons of each carbon are used in making hexagonal ring, fourth electron of each carbon is free to move. This makes graphite a good conductor of heat and electricity.

Further graphite has a two dimensional sheet like structure. These various sheets are held together by weak van der Waal's force of attraction. due to these weak forces of attraction, one layer can slip over the other. This makes graphite soft and a good lubricating agent.

10. (a) Glass is a translucent or transparent amorphous supercooled solid solution or we can say super cooled liquid of silicates and borates having a general formula  $\text{R}_2\text{O} \cdot \text{MO} \cdot 6\text{SiO}_2$ , where  $\text{R} = \text{Na}$  or  $\text{K}$  and  $\text{M} = \text{Ca}$ ,  $\text{Ba}$ ,  $\text{Zn}$  or  $\text{Pb}$ .

11. (b) Among the given compounds, the  $\text{NH}_3$  is most basic. Hence has highest proton affinity

12. (d) It is mercury because it exists as liquid at room temperature.

13. (d) The fluorine has low dissociation energy of  $\text{F}-\text{F}$  bond and reaction of atomic fluorine is exothermic in nature

14. (c) Helium is heavier than hydrogen although it is non-inflammable

15. (c) The maximum valency of beryllium is  $+2$  while that of aluminium is  $+3$ .

16. (b)  $\text{Al}_2\text{Cl}_6 + 12\text{H}_2\text{O} \rightleftharpoons 2[\text{Al}(\text{H}_2\text{O})_6]^{3+} + 6\text{Cl}^-$

17. (b)  $4\text{KI} + 2\text{CuSO}_4 \rightarrow \text{I}_2 + \text{Cu}_2\text{I}_2 + 2\text{K}_2\text{SO}_4$

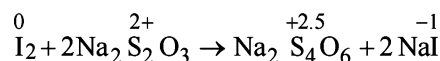

In this  $\text{CuI}_2$  is **not** formed.

18. (c) Hypophosphorous acid  $\text{H}-\text{O}-\overset{\text{H}}{\underset{\text{H}}{\text{P}}}-\text{O}-\text{H}$

Two H-atoms are attached to P atom.

19. (c) The  $\text{H}-\text{X}$  bond strength decreases from  $\text{HF}$  to  $\text{HI}$ . i.e.  $\text{HF} > \text{HCl} > \text{HBr} > \text{HI}$ . Thus  $\text{HF}$  is most stable while  $\text{HI}$  is least stable. This is evident from their decomposition reaction:  $\text{HF}$  and  $\text{HCl}$  are stable upto  $1473\text{K}$ ,  $\text{HBr}$

decreases slightly and  $\text{HI}$  dissociates considerably at  $713\text{K}$ . The decreasing stability of the hydrogen halide is also reflected in the values of dissociation energy of the  $\text{H}-\text{X}$  bond

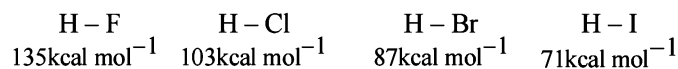

20. (b) The solution of aluminium chloride in water is acidic due to hydrolysis.

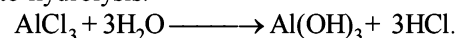

On heating it till dryness  $\text{Al}(\text{OH})_3$  is converted into  $\text{Al}_2\text{O}_3$

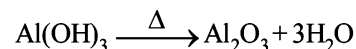

21. (d) In  $\text{SiO}_2$  (quartz), each of O-atom is shared between two  $\text{SiO}_4^{4-}$  tetrahedra.

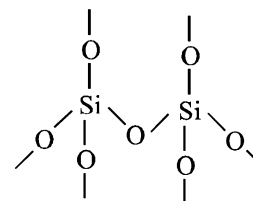

22. (d) In diborane structure  $\text{B}_2\text{H}_6$  there are two  $2\text{c}-2\text{e}$  bonds and two  $3\text{c}-2\text{e}$  bonds (see structure of diborane).

Structure of  $\text{B}_2\text{H}_6$ :

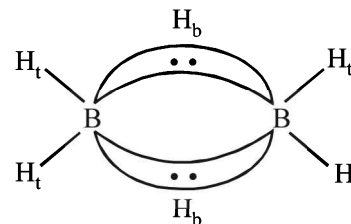

23. (b) The  $\text{HNO}_3$  is stronger than  $\text{HNO}_2$ . The more the oxidation state of N, the more is the acid character.

24. (b) The correct order of ionisation enthalpies is

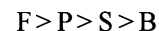

**NOTE:** On moving along a period ionization enthalpy increases from left to right and decreases from top to bottom in a group. But this trend breaks up in case of atom having fully or half filled stable orbitals.

In this case P has a stable half filled electronic configuration hence its ionisation enthalpy is greater in comparison to S. Hence the correct order is

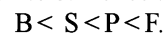

25. (b) During disproportionation same compound undergo simultaneous oxidation and reduction.

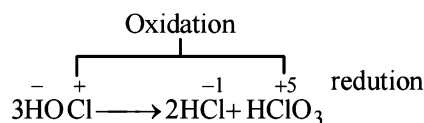

26. (d) Chlorine reacts with excess of ammonia to produce ammonium chloride and nitrogen.

27. (a)  $(\text{NH}_4)_2\text{SO}_4 + 2\text{H}_2\text{O} \longrightarrow 2\text{H}_2\text{SO}_4 + \text{NH}_4\text{OH}$

$\text{H}_2\text{SO}_4$  is strong acid and increases the acidity of soil.

28. (c) The correct formula of inorganic benzene is  $B_3N_3H_6$  so (d) is incorrect statement

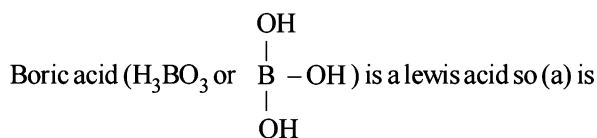

incorrect statement.

The coordination number exhibited by beryllium is 4 and not 6 so statement (b) is incorrect.

Both  $BeCl_2$  and  $AlCl_3$  exhibit bridged structures in solid state so (c) is correct statement.

29. (d) The products of the concerned reaction react each other forming back the reactants.

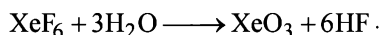

30. (a) The ease of formation and stability of hydrides decreases rapidly from  $NH_3$  to  $BiH_3$ . This is evident from their dissociation temperature which decreases from  $NH_3$  to  $BiH_3$ . As we go down the group the size of central atom increases and thus metal-hydrogen bond becomes weaker due to decreased overlap between the large central atom and small hydrogen atom.

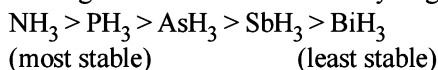

31. (d) Oxidation of sulphur varies from -2 to +6 in its various compounds.
32. (a) Boron cannot form  $BF_6^{3-}$  due to non-availability of d-orbitals.
33. (c) All the members form volatile halides of the type  $AX_3$ . All halides are pyramidal in shape. The bond angle decreases on moving down the group due to decrease in bond pair-bond pair repulsion.
- |             |            |            |
|-------------|------------|------------|
| $NCl_3$     | $PCl_3$    | $AsCl_3$   |
| $107^\circ$ | $94^\circ$ | $92^\circ$ |

34. (c) Acidic strength increases as the oxidation number of central atom increases.

Hence acidic strength order is

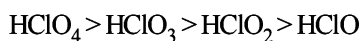

35. (a) Nitric oxide is paramagnetic in the gaseous state because of the presence of one unpaired electron in its outermost shell.

The electronic configuration of NO is

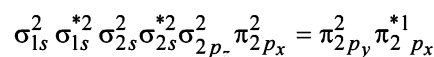

36. (b)  $CsI_3$  dissociates as

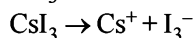

37. (b) ICl  
Order of reactivity of halogens



But, the interhalogen compounds are generally more reactive than halogens (except  $F_2$ ), since the bond between two dissimilar electronegative elements is weaker than the bond between two similar atoms i.e.  $X-X$

38. (c) Nitrogen and oxygen in air do not react to form oxides of nitrogen in atmosphere because the reaction between nitrogen and oxygen requires high temperature.

39. (b) Xe. As we move down the group, the melting and boiling points show a regular increase due to corresponding increase in the magnitude of their van der Waals forces of attraction as the size of the atom increases.

40. (c) Phosphorous acids contain P in +3 oxidation state.

Acid	Formula	Oxidation state of Phosphorous
Pyrophosphorous acid	$H_4P_2O_5$	+3
Pyrophosphoric acid	$H_4P_2O_7$	+5
Orthophosphorous acid	$H_3PO_3$	+3
Hypophosphoric acid	$H_4P_2O_6$	+4

41. (c) Reaction of Zn with dil.  $HNO_3$
- $$4Zn + 10HNO_3(\text{dil}) \longrightarrow 4Zn(NO_3)_2 + 5H_2O + N_2O$$
- (Zn reacts differently with very dilute  $HNO_3$ )

Reaction of Zn with conc.  $HNO_3$

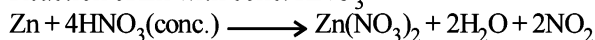



# Section-A JEE Advanced/ IIT-JEE

## A. Fill in the Blanks

1.  $\text{K}[\text{Ag}(\text{CN})_2]$
2.  $\text{PbO}_2$ ;
3. Zinc;
4. **Hydration/solvation**; [A substance dissolves when its  $\Delta H_{\text{hydration}} > \text{lattice energy}$ ].
5.  $\text{FeSO}_4 \cdot 7\text{H}_2\text{O}$ ,  $\text{ZnSO}_4 \cdot 7\text{H}_2\text{O}$ ;
6. **Paramagnetism**;  
[ $\text{Mn}(\text{H}_2\text{O})_6^{2+}$  shows paramagnetism because of presence of 5 unpaired electrons in the outer most orbital ( $3d^5$ ) of  $\text{Mn}^{2+}$ ].
7. **Hexammine cobalt (III) chloride**
8. **zero**
9.  $\text{H}_2\text{S}$ ; It is due to formation of sulphide of silver ( $\text{Ag}_2\text{S}$ ) which is black.

## B. True/False

1. **False** : Copper metal does not reduce  $\text{Fe}^{2+}$  in an acidic medium.
2. **True** : Hydration energy of  $\text{AgF}$  is appreciably higher than its lattice energy because of smaller  $\text{F}^-$  ion and thus  $\text{AgF}$  is soluble in water. In rest of the halides, lattice energy is more than hydration energy to make them insoluble.
3. **True** : Insolubility of  $\text{AgCl}$  in  $\text{H}_2\text{O}$  is due to its high lattice energy on account of strong van der Waals attraction between silver and chloride ions in addition to electrostatic attraction between them. Further  $\text{AgCl}$  forms a complex with conc.  $\text{NaCl}$  solution and is therefore soluble.
4. **False** : Divalent zinc exhibits diamagnetism (and not paramagnetism) because it has no unpaired electron.
5. **False** : Octahedral complexes of  $\text{Fe}(\text{III})$  like  $[\text{Fe}(\text{CN})_6]^{3-}$  are low spin ( $d^2sp^3$  hybridization) with one unpaired electron and have magnetic moment of about 1.9 BM. On the other hand, complexes of  $\text{Fe}(\text{II})$  like  $[\text{Fe}(\text{CN})_6]^{2-}$  are low spin complex ( $d^2sp^3$ ) has no unpaired electron and thus diamagnetic.
6. **True** :  $\text{Cu}^+$  is the intermediate oxidation state between  $\text{Cu}^{++}$  and  $\text{Cu}$ . If the reduction potential from the intermediate oxidation state to the lower one is more positive than from the higher to the intermediate, then the intermediate state will undergo disproportionation.



## C. MCQs with One Correct Answer

1. (a)  $\text{Zn} + \text{H}_2\text{SO}_4 \longrightarrow \text{ZnSO}_4 + \text{H}_2$   
 $\text{Zn} + 2\text{NaOH} \longrightarrow \text{Na}_2[\text{ZnO}_2] + \text{H}_2$   
 $\therefore$  Ratio of  $\text{H}_2$  evolved is 1 : 1.
2. (d)  $\therefore$  Basicity of hydroxides decreases on moving left to right in a period.
3. (b) German silver is alloy of  $\text{Cu} + \text{Zn} + \text{Ni}$

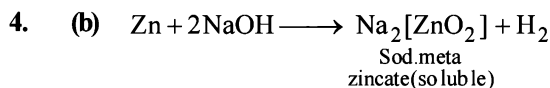

5. (b)  $\uparrow\downarrow \uparrow\downarrow \uparrow\downarrow \uparrow \uparrow$ . It has 2 unpaired electrons.  
 $3d$  orbital of  $\text{Ni}^{2+}$  ion. At No. of  $\text{Ni} = 28$ .

6. (c) Hypo solution ( $\text{Na}_2\text{S}_2\text{O}_3$ ) is used in photography to remove the unaffected  $\text{AgBr}$  in the form of soluble complex.

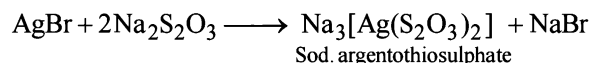

7. (d) Conc.  $\text{HNO}_3$  renders iron passive by forming a thin protective film of  $\text{Fe}_3\text{O}_4$  on its surface.

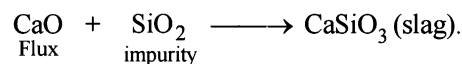
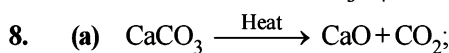

9. (a) Zinc-copper couple is obtained by mixing zinc dust with copper gauze.

10. (b)  $\text{Mn}^{2+}$  in  $\text{MnSO}_4 \cdot 4\text{H}_2\text{O}$  has  $d^5$  configuration (five unpaired electrons);  $\text{Cu}^{2+}$  in  $\text{CuSO}_4 \cdot 5\text{H}_2\text{O}$  has  $d^9$  configuration (one unpaired electron);  $\text{Fe}^{2+}$  in  $\text{FeSO}_4 \cdot 6\text{H}_2\text{O}$  has  $d^6$  configuration (four unpaired electron); and  $\text{Ni}^{2+}$  in  $\text{NiSO}_4 \cdot 6\text{H}_2\text{O}$  has  $d^8$  configuration (two unpaired electron). Thus  $\text{CuSO}_4 \cdot 5\text{H}_2\text{O}$  has lowest degree of paramagnetism.

11. (c)

Atom/Ion Complex	Configuration	No. of unpaired electrons	Magnetic nature
$\text{Ni}^{2+} (d^8)$ $[\text{NiCl}_4]^{2-}$	$3d$ $4s$ $4p$ $\uparrow\downarrow \uparrow\downarrow \uparrow\downarrow \uparrow \uparrow$ $\square$ $\square$ $\square$ $\uparrow\downarrow \uparrow\downarrow \uparrow\downarrow \uparrow \uparrow$ :      :      :      :	2	Paramagnetic
$[\text{Ni}(\text{CN})_4]^{2-}$	$sp^3$ $\uparrow\downarrow \uparrow\downarrow \uparrow\downarrow \uparrow\downarrow$ :      :      :      : Rearrangement $dsp^2$	0	Diamagnetic
$\text{Ni} (d^8 s^2)$ $[\text{Ni}(\text{CO})_4]$	$\uparrow\downarrow \uparrow\downarrow \uparrow\downarrow \uparrow \uparrow$ $\uparrow\downarrow$ $\square$ $\square$ $\uparrow\downarrow \uparrow\downarrow \uparrow\downarrow \uparrow\downarrow \uparrow\downarrow$ :      :      :      : Rearrangement $sp^3$	2	Paramagnetic
		0	Diamagnetic

12. (c) Solder is an alloy containing  $\text{Sn} - 67\%$  and  $\text{Pb} - 33\%$ .

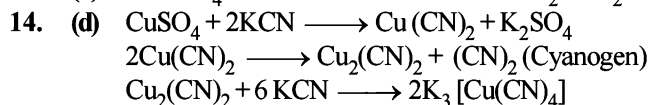
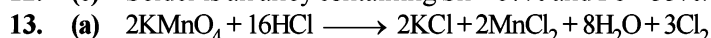

15. (a)  $\text{HgS}$  does not dissolve in hot dil.  $\text{HNO}_3$

16. (c) **TIPS/FORMULAE:**

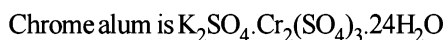

The filtrate is yellow due to  $\text{CrO}_4^{2-}$  ion and residue is brown due to  $\text{Fe}(\text{OH})_3$ .

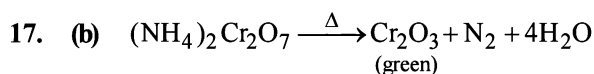

Hence green coloured powder blown in the air is  $\text{Cr}_2\text{O}_3$ .

18. (a) The reaction of  $\text{MnO}_4^-$  and  $\text{SO}_3^{2-}$  in acidic medium is derived as follows:

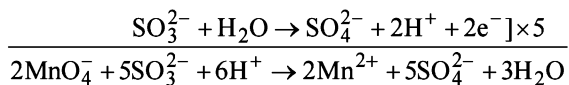
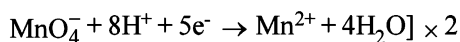

Hence, 2 mole  $2\text{MnO}_4^- \equiv 5 \text{ mol SO}_3^{2-}$

i.e.,  $\frac{2}{5} \text{ mol MnO}_4^- \equiv 1 \text{ mol SO}_3^{2-}$

19. (d) Organometallic compounds are those compounds in which metal atom is directly bonded with C-atom.  $\text{H}_3\text{C}-\text{Li}$ .
20. (b) The electronic configurations of cations in the given salts are  
 $\text{Ag}^+ (4d^{10}), \text{Cu}^{2+} (3d^9), \text{Mg}^{2+} (2s^2, 2p^6), \text{Cu}^+ (3d^{10})$   
 Only  $\text{Cu}^{2+}$  ion has one unpaired electron in 3d orbital and so, its salt is expected to be coloured.
21. (b) The structure of  $\text{Cr}_2\text{O}_7^{2-}$

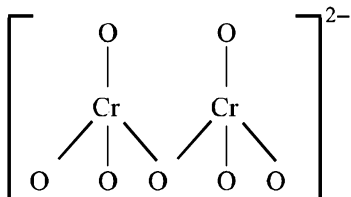

There are six normal Cr – O bonds and two bridged Cr – O bonds.

The six normal Cr – O bonds are expected to be equivalent and different from those of the bridged Cr – O bonds.

22. (c) **NOTE :** In metal carbonyl the metal is in **zero** oxidation state.

In  $\text{Ni}(\text{CO})_4$ , O.N. of Ni = 0

For Ni (Z = 28)

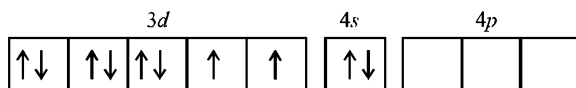

In presence of CO two 4s electrons pair up, thus

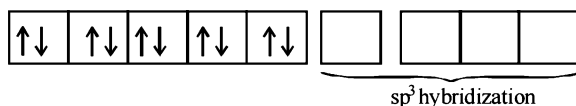

In  $\text{Ni}(\text{PPh}_3)_2\text{Cl}_2$ , O.N. of Ni = +2

For  $\text{Ni}^{2+}$

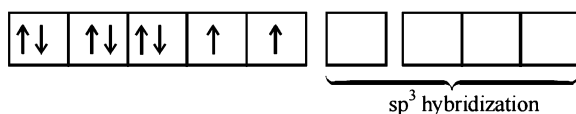

$\text{PPh}_3$  and  $\text{Cl}^-$  can't pair up d-electrons, leading to  $sp^3$  hybridization leading to tetrahedral geometry.

23. (c) Haematite ore ( $\text{Fe}_2\text{O}_3$ ) is first reduced to cast iron which is then oxidised for removing carbon (impurity) as  $\text{CO}_2$ .

24. (a) In  $[\text{MnO}_4]^-$ , Mn is in +7 oxidation state.

Electronic configuration of Mn (Z = 25) :  $[\text{Ar}] 3d^5 4s^2$

Electronic configuration of  $\text{Mn}^{7+}$  :  $[\text{Ar}] 3d^0 4s^0$

Central atom in other ions have definite number of d electrons

No. of electrons

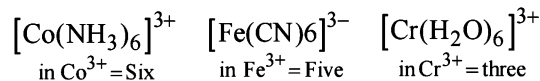

25. (b)  $2\text{Fe} + 3\text{Cl}_2$  (dry)  $\rightarrow 2\text{FeCl}_3$  (anhydrous)

26. (a) Stable oxidation state of Mn in alkaline medium is +6. So,  $\text{MnO}_2$  is oxidised to  $\text{K}_2\text{MnO}_4$  (purple green) by atmospheric oxygen in KOH medium.

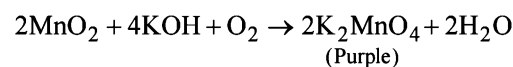

27. (a)  $2\text{Au} + 4\text{CN}^- + \text{H}_2\text{O} + \frac{1}{2}\text{O}_2 \rightarrow 2[\text{Au}(\text{CN})_2]^- + 2\text{OH}^-$

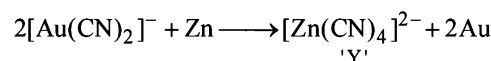

28. (b) The configuration of  $\text{Ni}^{2+}$  is  $3d^8$ . For the elements of the first transition series,  $\text{Cl}^-$  behaves as a weak field/high spin ligand. Hence Ni in  $[\text{NiCl}_4]^{2-}$  is  $sp^3$  hybridised leading to tetrahedral shape.

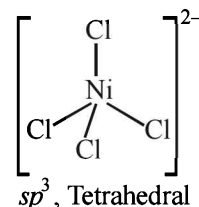

29. (c) **TIPS/FORMULAE :**

$$\mu = \sqrt{n(n+2)} \text{ BM} \quad (\mu = \text{spin magnetic moment})$$

Here Co is present as  $\text{Co}^{2+}$  ion which has 3 unpaired electrons. So the spin magnetic moment will be

$$\sqrt{3(3+2)}, \text{ i.e. } \sqrt{15} \text{ BM.}$$

30. (a)  $6\text{MnO}_4^- + \text{I}^- + 6\text{OH}^- \rightarrow 6\text{MnO}_4^{2-} + \text{IO}_3^- + 3\text{H}_2\text{O}$

31. (a)  $(\text{NH}_4)_2\text{Cr}_2\text{O}_7 \xrightarrow{\text{heat}} \text{N}_2 + \text{Cr}_2\text{O}_3 + 4\text{H}_2\text{O}$

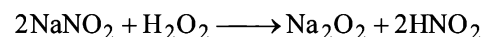
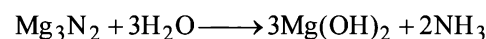
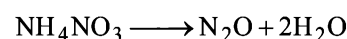
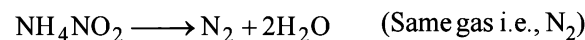

32. (b) Colour of transition metal ion salt is due to d-d transition of unpaired electrons of d-orbital. Metal ion salt having similar number of unpaired electrons in d-orbitals

shows similar colour in aqueous medium.

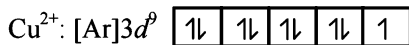
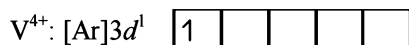

Number of unpaired electrons = 1

33. (a)  $Co(NH_3)_4Br_2Cl$  will show both geometrical and ionization isomerism.

$[Co(NH_3)_4Br_2]Cl$  and  $[Co(NH_3)_4BrCl]Br$  are ionization isomers and geometrical isomers are

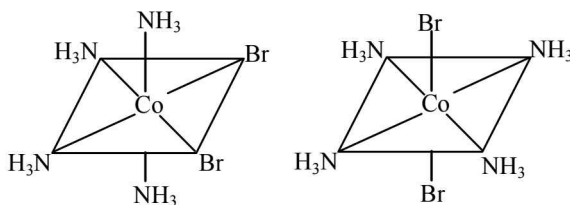

*cis*

*trans*

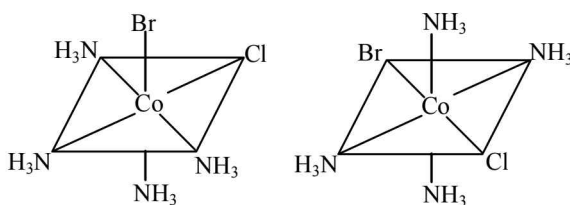

*cis*

*trans*

34. (a)  $CuSO_4 + 2KCN \longrightarrow Cu(CN)_2 + K_2SO_4$

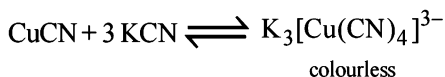
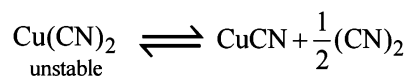

35. (d) An anionic carbonyl complex can delocalise more electron density to antibonding pi-orbital of CO and hence, lowers the bond order.
36. (b) In the presence of oxygen, Ag metal forms a water soluble complex  $Na[Ag(CN)_2]$  with dilute solution of NaCN

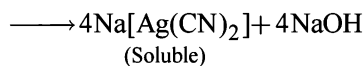
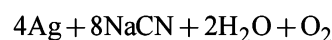

37. (c) **NOTE** : Colour is due to d – d transitions. Coloured compounds contain partly filled d-orbital.

The oxidation state of copper in various compounds is + 1 and + 2. In  $CuF_2$  it is in + 2 oxidation state. In + 2 state its configuration is

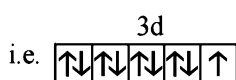
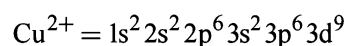

It has one unpaired electron due to this it is coloured.

The colour is due to d-d transitions.

(**NOTE** :  $CuF_2$  possesses blue colour in crystalline form)

38. (c) The correct IUPAC name of the given compound is tetramminenickel (II) - tetrachloronickelate (II) thus (c) is the correct answer.

39. (b) **NOTE** : : In carbonyls O.S. of metal is zero  
In  $[Ni(CO)_4]$ , the oxidation state of nickel is zero. Its configuration in  $Ni(CO)_4$  is

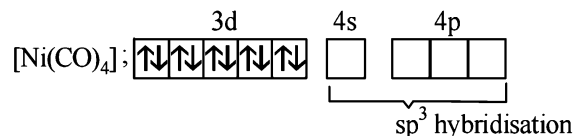

In  $[Ni(CN)_4]^{2-}$  the oxidation state of Ni is 2+ and its configuration is

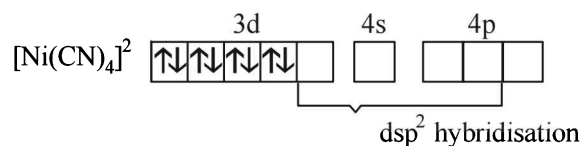

Thus the hybridisations of nickel in these compounds are  $sp^3$  and  $dsp^2$  respectively.

Hence (b) is the correct answer.

40. (a) Chromium in  $Cr(CO)_6$  is in zero oxidation state and has  $[Ar]^{18} 3d^5 4s^1$  as the electronic configuration. However, CO is a strong ligand, hence pairing up of electrons takes place leading to following configuration in  $Cr(CO)_6$ .

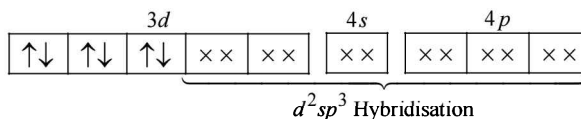

Since the complex has no unpaired electron, its magnetic moment is zero.

41. (b) Ionisation isomer of  $[Cr(H_2O)_4Cl(NO_2)]Cl$  is  $[Cr(H_2O)_4Cl_2]NO_2$ .

42. (c) The correct structure of EDTA is

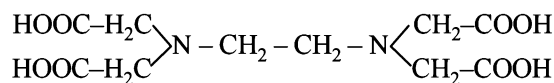

43. (b)  $[NiCl_4]^{2-}$ , O.S. of Ni = +2

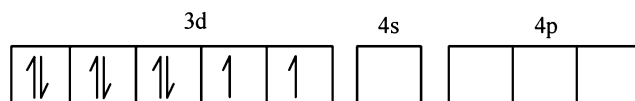
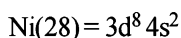

$Cl^-$  being weak ligand it cannot pair up the two electrons present in 3d orbital

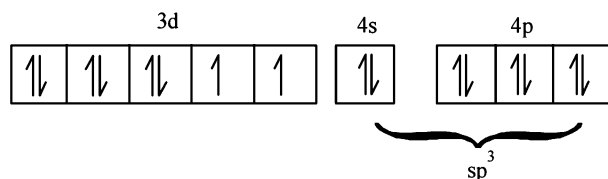

No. of unpaired electrons = 2

Magnetic moment,  $\mu = 2.82 \text{ BM}$ .



44. (c)

Complex	No. of electrons in outer <i>d</i> orbital	No. of unpaired electron (s)
[Fe(CN) <sub>6</sub> ] <sup>3-</sup>	3 <i>d</i> <sup>5</sup>	1 (CN <sup>-</sup> causes pairing of electrons)
[Co(NH <sub>3</sub> ) <sub>6</sub> ] <sup>3+</sup>	3 <i>d</i> <sup>6</sup>	—
[Co(oxal.) <sub>3</sub> ] <sup>3-</sup>	3 <i>d</i> <sup>6</sup>	—
[Ni(H <sub>2</sub> O) <sub>6</sub> ] <sup>2+</sup>	3 <i>d</i> <sup>8</sup>	2
[Pt(CN) <sub>4</sub> ] <sup>2-</sup>	5 <i>d</i> <sup>8</sup>	D (CN <sup>-</sup> causes pairing of electrons)
[Zn(H <sub>2</sub> O) <sub>6</sub> ] <sup>2+</sup>	3 <i>d</i> <sup>10</sup>	—

Thus L, M, O and P are diamagnetic.

45. (d) [Co(H<sub>2</sub>O)<sub>4</sub>(NH<sub>3</sub>)<sub>2</sub>]Cl<sub>3</sub>  
= Diamminetetraaquacobalt (III) chloride.
46. (a) CuSO<sub>4</sub> will be absorbing orange-red colour and hence will be of blue colour.
47. (c) In both states (paramagnetic and diamagnetic) of the given complex, Ni exists as Ni<sup>2+</sup> whose electronic configuration is [Ar] 3*d*<sup>8</sup>4*s*<sup>0</sup>.

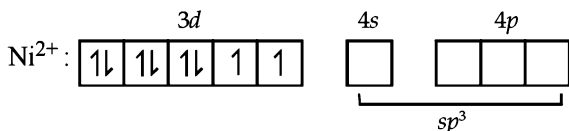

In the above paramagnetic state the geometry of the complex is *sp*<sup>3</sup> giving tetrahedral geometry. The diamagnetic state is achieved by pairing of electrons in 3*d* orbital.

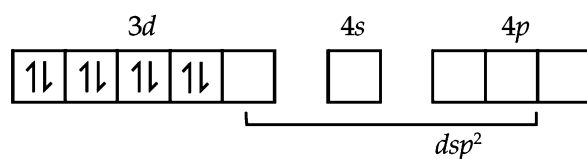

Thus the geometry of the complex will be *dsp*<sup>2</sup> giving square planar geometry.

48. (b) The electronic configuration of central metal ion in complex ions P, Q and R are

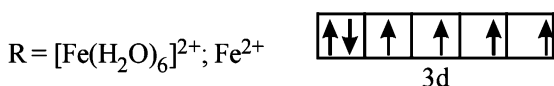
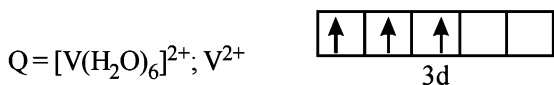

Higher the no. of unpaired electron(s), higher will be magnetic moment.

Thus the correct order of spin only magnetic moment is Q < R < P

49. (b)
- |    | Compound/Ion   | Magnetic nature of compound |
|----|--|-----------------------------|
| 1. | [Ni(CO) <sub>4</sub> ]                                 | Diamagnetic                 |
| 2. | [NiCl <sub>4</sub> ] <sup>2-</sup>                     | Paramagnetic                |
| 3. | [Co(NH <sub>3</sub> ) <sub>4</sub> Cl <sub>2</sub> ]Cl | Diamagnetic                 |
| 4. | Na <sub>3</sub> [CoF <sub>6</sub> ]                    | Paramagnetic                |
| 5. | Na <sub>2</sub> O <sub>2</sub>                         | Diamagnetic                 |
| 6. | CsO <sub>2</sub>                                       | Paramagnetic                |

So total number of paramagnetic compounds is 3.

#### D. MCQs with One or More Than One Correct

1. (b, c)  $2\text{MnO}_2 + 4\text{KOH} + \text{O}_2 \xrightarrow{\text{heat}} 2\text{K}_2\text{MnO}_4 + 2\text{H}_2\text{O}$ ;  
 $2\text{KOH} + \text{HCHO} + 2\text{KMnO}_4 \longrightarrow \text{K}_2\text{MnO}_4 + \text{H}_2\text{O} + \text{HCOOH}$
2. (c, d) Aqueous solution of Co(NO<sub>3</sub>)<sub>2</sub> and CrCl<sub>3</sub> in which Co<sup>2+</sup> (*d*<sup>7</sup>) and Cr<sup>3+</sup> (*d*<sup>3</sup>) contains incompletely filled *d*-orbitals are coloured.
3. (b) Highest paramagnetic character will be shown by the ion having maximum number of unpaired electrons in their *d*-subshells.

<sup>25</sup>Cr<sup>3+</sup> has 3 unpaired electrons ;

<sup>26</sup>Fe<sup>2+</sup> has 4 unpaired electrons

<sup>29</sup>Cu<sup>2+</sup> has 1 unpaired electrons ;

<sup>30</sup>Zn<sup>2+</sup> has no unpaired electrons

So (a), (b) & (c) show paramagnetism. Out of which (b) has the highest paramagnetism.

4. (b, c) Brass : Cu (60-80%), Zn (40-20%); Gun Metal : Cu (87%), Sn (10%), Zn (3%).
5. (c) The magnetic moment ( $\mu$ ) of a species is related to its number of unpaired electrons (*n*) in form of following expressions.

$$\mu = \sqrt{n(n+2)} \text{ B.M}$$

The number of unpaired electrons in the given pairs are as follows:

$$\text{Fe}^{2+} = 1s^2, 2s^2 2p^6, 3s^2 3p^6 3d^6$$

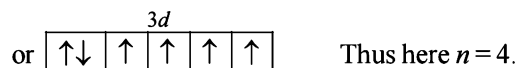

$$\text{Fe}^{3+} = 1s^2, 2s^2 2p^6, 3s^2 3p^6 3d^5$$

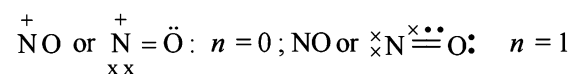

The given combinations differ in the number of unpaired electrons. Hence these can be differentiated by the measurement on the solid state magnetic moment of nitroprusside ion.

6. (a, c) Mn makes steel harder and increases its elasticity and tensile strength. Further Mn acts as deoxidiser. MnO reacts with S present in cast iron, gets oxidised and then combine to form slag.

7. (d) The metal to ligand bonding creates a synergic effect which strengthens the bond between CO and the metal (Fe) leading to contraction of bond between C and O of CO.

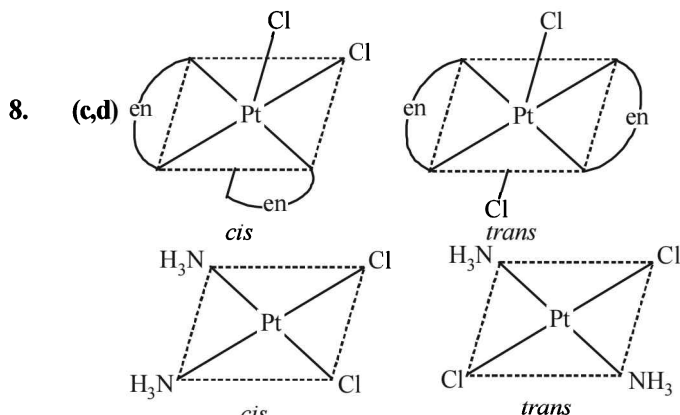

9. (a,d) In acidic medium  
 $\text{MnO}_4^- \longrightarrow \text{Mn}^{2+}$   
 Change in oxidation state of Mn = 7 - 2 = 5  
 Thus electrons lost = 5  
 In neutral medium

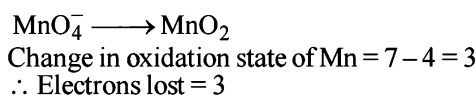

10. (b,c,d)  $\text{Cu}^{2+}$  ions will react with  $\text{CN}^-$  and  $\text{SCN}^-$  forming  $[\text{Cu}(\text{CN})_4]^{3-}$  and  $[\text{Cu}(\text{SCN})_4]^{3-}$  leading the reaction in the backward direction.

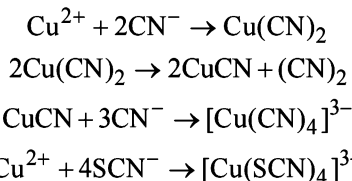

$\text{Cu}^{2+}$  also combines with  $\text{CuCl}_2$  which reacts with Cu to produce  $\text{CuCl}$  pushing the reaction in the backward direction.

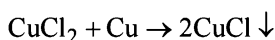

11. (a, c, d)

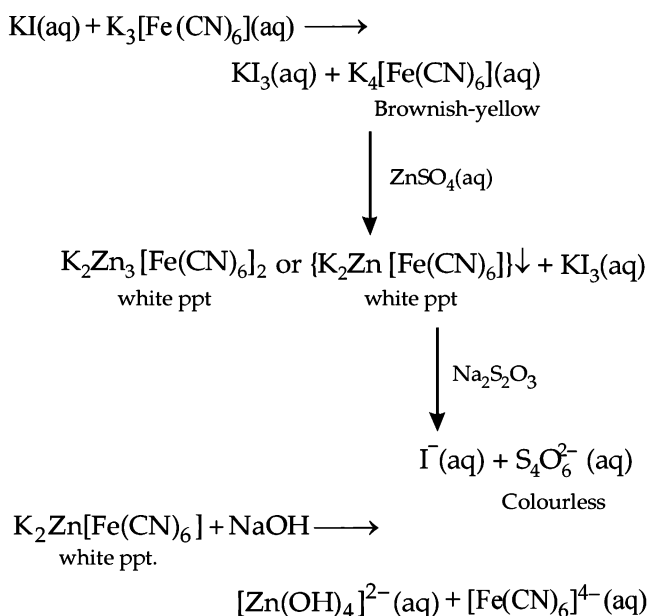

12. (b,d) The pair of complex ions  $[\text{Co}(\text{NH}_3)_4\text{Cl}_2]^+$  and  $[\text{Pt}(\text{NH}_3)_2(\text{H}_2\text{O})\text{Cl}]^+$  show geometrical isomerism. The pair of complexes  $[\text{Pt}(\text{NH}_3)_3(\text{NO}_3)]\text{Cl}$  and  $[\text{Pt}(\text{NH}_3)_3\text{Cl}]\text{Br}$  show ionisation isomerism. The other pairs given do not have same type of isomerism.
13. (a, b, c)  $\text{Na} + \text{NH}_3$  (excess)  $\rightarrow$  Dilute solution of Na in liq.  $\text{NH}_3 \rightarrow$  Paramagnetic  
 $\text{K} + \text{O}_2$  (excess)  $\rightarrow \text{KO}_2$  ( $\text{O}_2^-$  is paramagnetic)  
 $\text{Cu} + \text{HNO}_3$  (dil.)  $\rightarrow \text{Cu}(\text{NO}_3)_2 + \text{NO}$   
 (NO is paramagnetic)

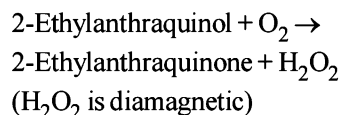

14. (a, b, c)  $\text{Cr}^{2+}$  is a reducing agent and  $\text{Mn}^{3+}$  is an oxidizing agent and both have electronic configuration  $d^4$ .

$$E^\circ_{\text{Cr}^{3+}/\text{Cr}^{2+}} = -0.41\text{V} \quad E^\circ_{\text{Mn}^{3+}/\text{Mn}^{2+}} = 1.51\text{V}$$

Above  $E^\circ$  values explains reducing nature of  $\text{Cr}^{2+}$  and oxidizing behaviour of  $\text{Mn}^{3+}$ .

15. (a, b)

### E. Subjective Problems

1. (i) Since the compound (A) on strong heating gives two oxides of sulphur (C and D) which might be  $\text{SO}_2$  and  $\text{SO}_3$ , it must be a **sulphate**.  
 (ii) The reaction of compound (E) with thiocyanate to give blood red coloured compound (H) indicates that (E) must have  **$\text{Fe}^{3+}$  ion**.  
 Thus the compound (A) must be ferrous sulphate,  $\text{FeSO}_4 \cdot 7\text{H}_2\text{O}$ , which explains all given reactions as below ( $\text{Fe}^{2+}$  ion of  $\text{FeSO}_4$  is changed to  $\text{Fe}^{3+}$  during heating).

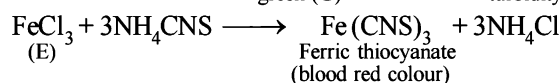
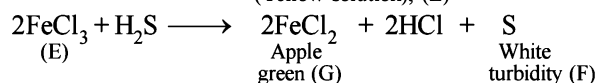
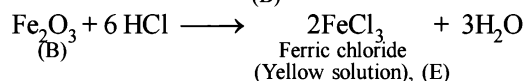
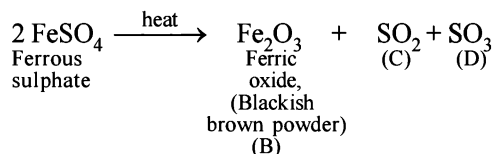
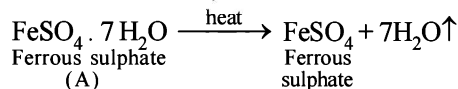

2. (i)  $\text{ZnCO}_3 \xrightarrow{\Delta} \text{ZnO} + \text{CO}_2$   
 (A)                      (C)                      (B)  
 (ii)  $\text{ZnO} + 2\text{HCl} \longrightarrow \text{H}_2\text{O} + \text{ZnCl}_2$   
 (C)                      (soluble)  
 (iii)  $2\text{ZnCl}_2 + \text{K}_4[\text{Fe}(\text{CN})_6] \longrightarrow 4\text{KCl} + \text{Zn}_2[\text{Fe}(\text{CN})_6] \downarrow$   
 (white ppt)  
 (iv)  $\text{ZnCO}_3 + \text{HCl} \longrightarrow \text{CO}_2 + \text{ZnCl}_2$   
 (A)                      (soluble)  
 (v)  $\text{CO}_2 + \text{Ca}(\text{OH})_2 \longrightarrow \text{CaCO}_3 + \text{H}_2\text{O}$   
 (B)                      (Milky)  
 (vi)  $\text{CaCO}_3 + \text{CO}_2 + \text{H}_2\text{O} \longrightarrow \text{Ca}(\text{HCO}_3)_2$   
 (soluble)

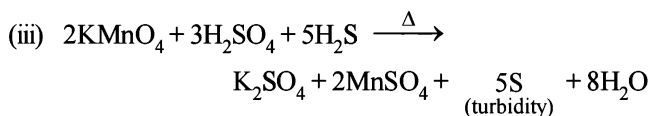
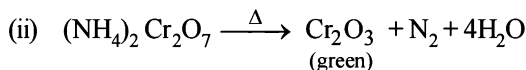
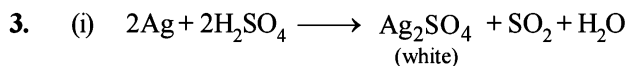
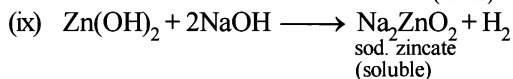
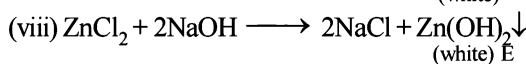
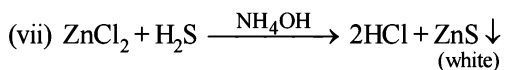

4. On standing  $\text{FeCl}_3$  is hydrolysed and produces colloidal solution of  $\text{Fe(OH)}_3$  which is in form of brown precipitate.

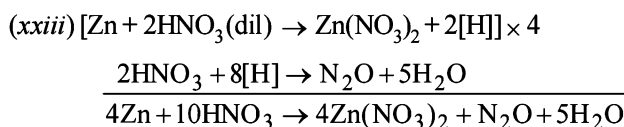
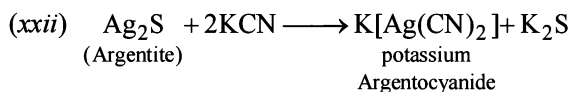
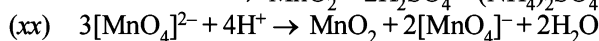
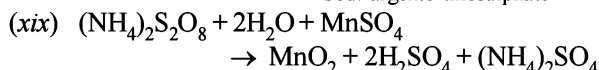
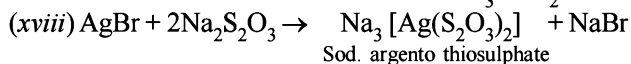
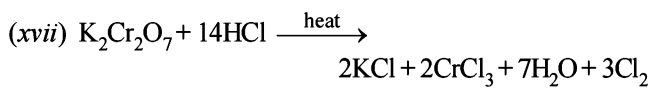
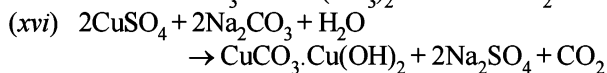
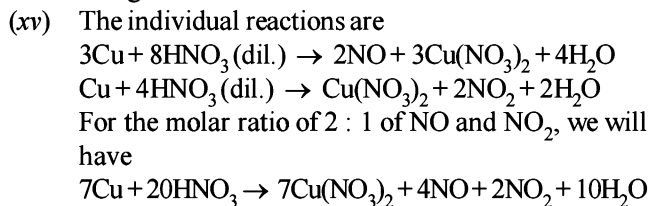
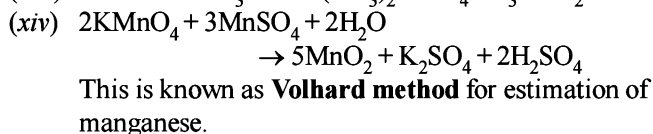
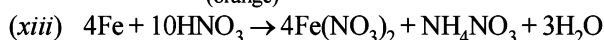
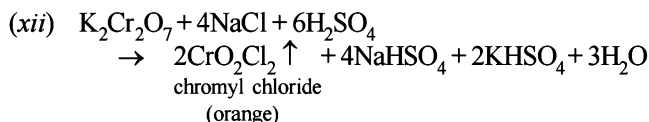
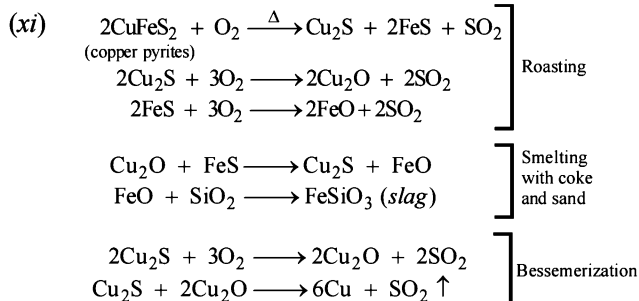
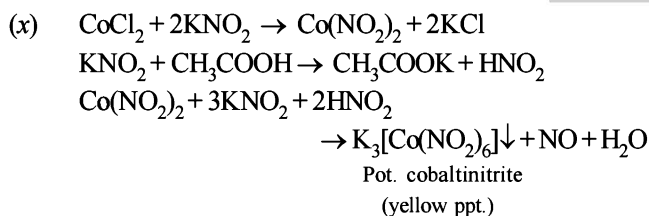
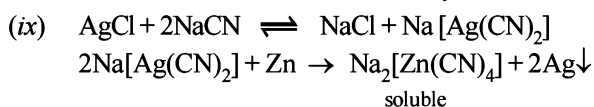
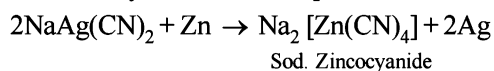
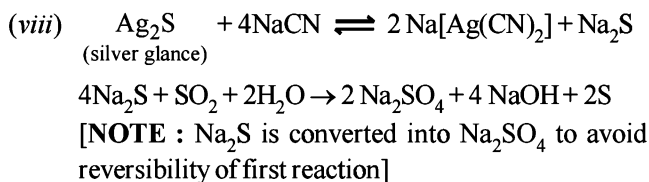
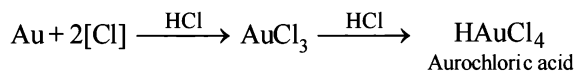
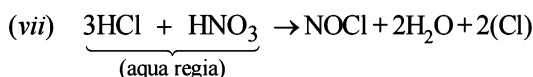
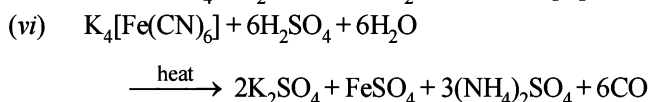
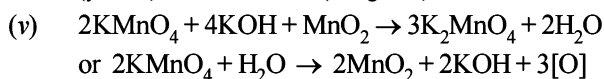
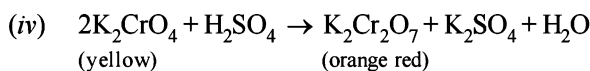
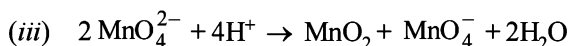
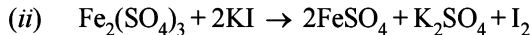
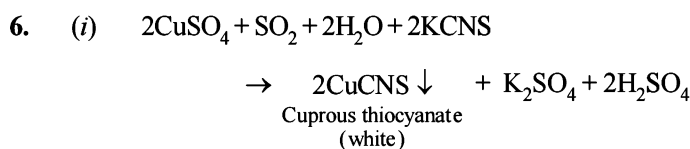
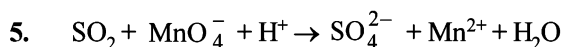
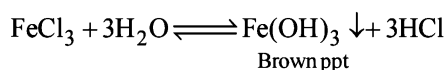

7. Equations for extraction of silver from its sulphide ore.

**Cyanide Process :**

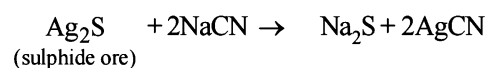



22.  $[\text{Co}(\text{NH}_3)_6]^{3+}$

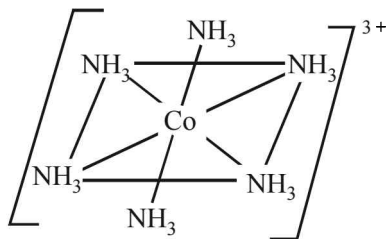
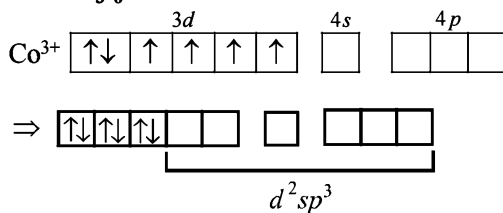

Octahedral complex, d<sup>2</sup>sp<sup>3</sup> hybridisation

$[\text{Ni}(\text{CN})_4]^{2-}$

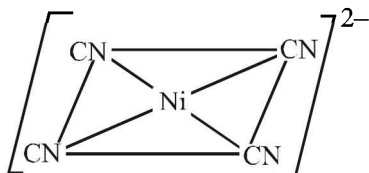
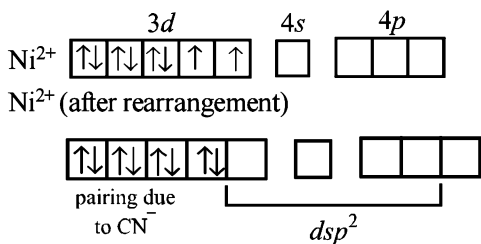

Square planar dsp<sup>2</sup> hybridisation

$[\text{Ni}(\text{CO})_4]$

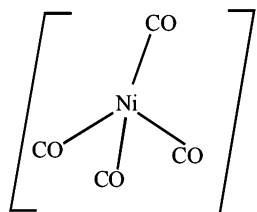
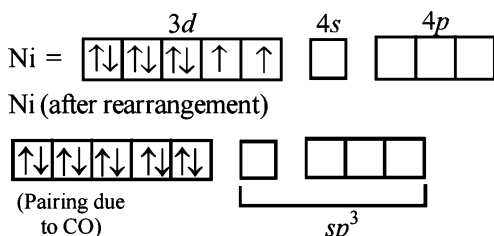

Tetrahedral (sp<sup>3</sup> hybridisation)

23. (i) Argentite is Ag<sub>2</sub>S. Silver is extracted from its ore argentite (silver glance, Ag<sub>2</sub>S) as follows :

- (1) Silver glance is concentrated by froth flotation.
- (2) Leaching : The concentrated ore is ground to fine powder and dissolved in dilute solution of sodium cyanide.

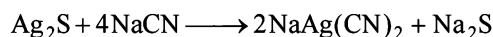

Oxygen of air converts Na<sub>2</sub>S to Na<sub>2</sub>SO<sub>4</sub> thereby preventing reaction to take place in the reversible direction.

(3) Recovery of silver.

Silver is precipitated out by adding electropositive metal, Zn.

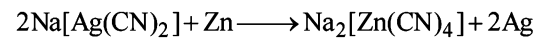

(ii) For development, activated grains are preferentially reduced by mild reducing agents like hydroquinone

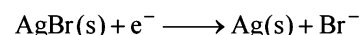
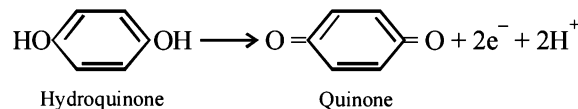

(Reduction of activated AgBr to elemental silver.)

The photographic film is permanently fixed by immediately washing out any non activated AgBr grains in hypo emulsion.

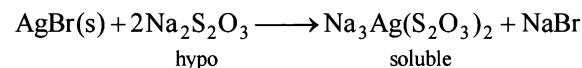

24. Compound (A) on treatment with AgNO<sub>3</sub> gives white precipitate of AgCl, which is readily soluble in dil. aq. NH<sub>3</sub>. Therefore it has at least one Cl<sup>-</sup> ion in the ionization sphere furthermore chromium has coordination number equal to 6. So its formula is  $[\text{Cr}(\text{NH}_3)_4\text{BrCl}]\text{Cl}$ .

Compound (B) on treatment with AgNO<sub>3</sub> gives pale yellow precipitate of AgBr soluble in conc. NH<sub>3</sub>. Therefore it has Br<sup>-</sup> in the ionization sphere. So its formula is  $[\text{Cr}(\text{NH}_3)_4\text{Cl}_2]\text{Br}$ .

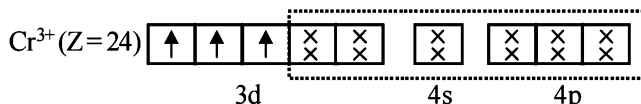

State of hybridization of chromium in both (A) and (B) is d<sup>2</sup>sp<sup>3</sup>.

Spin magnetic moment of (A) or (B),

$$\mu_{\text{spin}} = \sqrt{n(n+2)} = \sqrt{3(3+2)} = \sqrt{15} = 3.87 \text{ BM}$$

25. Cl<sup>-</sup> is a weak ligand which is unable to pair the electrons of Ni<sup>2+</sup>. Therefore, here hybridisation is sp<sup>3</sup> and shape will be tetrahedral.

Electronic configuration of Ni<sup>2+</sup> (No. of electrons = 26) in presence of Cl<sup>-</sup> ion, a weak ligand.

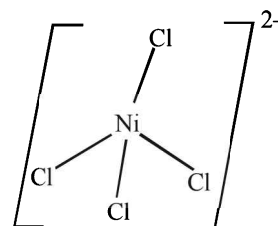
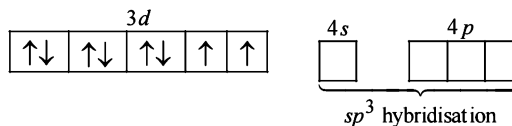

$$\text{Magnetic moment of } [\text{NiCl}_4]^{2-} = \sqrt{2(2+2)} = 2.82 \text{ BM}$$

On the other hand, CN<sup>-</sup> is a strong ligand which pairs up the

electrons of  $\text{Ni}^{2+}$ . Therefore, here hybridisation is  $dsp^2$  and shape will be square planar.

Electronic configuration of  $\text{Ni}^{2+}$  in presence of  $\text{CN}^-$  ion, a strong ligand.

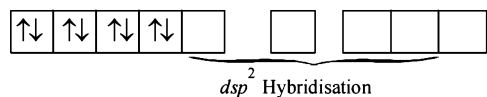

For structure of  $[\text{Ni}(\text{CN})_4]^{2-}$ , refer question 24 in Section (E).

Magnetic moment of  $[\text{Ni}(\text{CN})_4]^{2-} = \sqrt{0(0+2)} = 0.0 \text{ BM}$

26. The spin magnetic moment,  $\mu$  of the complex is 1.73 BM.

$$\mu = \sqrt{n(n+2)} = 1.73 \Rightarrow n = 1$$

It means that nucleus of the complex, chromium ion **has one unpaired electron**. So the ligand NO is **unit positively charged**.

**IUPAC name :**

Potassium amminetetracyanonitrosochromate (I).

- (a) Electronic configuration of  $\text{Cr}^+$  :

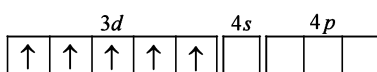

- (b) Electronic configuration of  $\text{Cr}^+$  under the influence of strong field ligand  $\text{CN}^-$

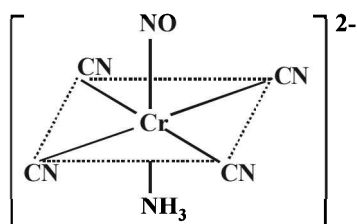
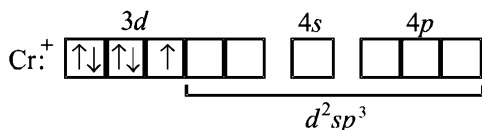

So, Hybridization :  $d^2sp^3$ ; Shape : Octahedral

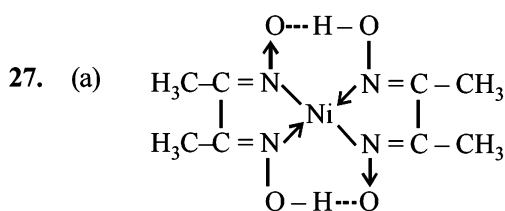

Bis(dimethylglyoximate) nickel (II)

- (b) Charge on Ni in the complex is +2 and it is  $dsp^2$  hybridised
- (c) Since number of unpaired electrons in  $\text{Ni}^{2+}$  is zero, the complex is diamagnetic.
28. Calcination of the ore  $A_1$  to form  $\text{CO}_2$  indicates that  $A_1$  should be a carbonate. Further, reaction of  $A_1$  with  $\text{HCl}$  and  $\text{KI}$  to evolve  $\text{I}_2$  indicates that  $A_1$  would also be hydroxide. So the possible formula for the ore, should be  $\text{CuCO}_3 \cdot \text{Cu}(\text{OH})_2$  which explains all the given reactions

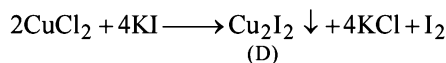
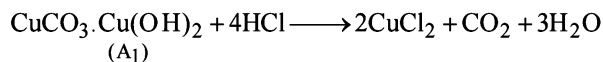
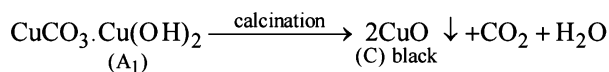

Roasting of  $A_2$  gives gas  $G$  whose nature is identified as  $\text{SO}_2$  as it gives green colour with acidified  $\text{K}_2\text{Cr}_2\text{O}_7$ . So  $A_2$  should be sulphide of copper.

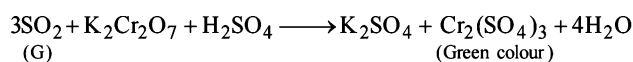
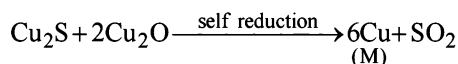
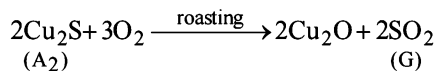

29.  $\text{Fe}^{3+} + \text{SCN}^- \longrightarrow [\text{Fe}(\text{SCN})(\text{H}_2\text{O})_5]^{2+}$
- (excess)  (blood red)   
 (A)

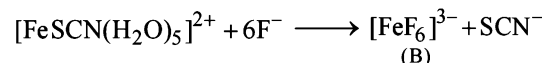

IUPAC name of A is pentaquathiocyanatoferrate (III) ion

IUPAC name of B is hexafluoroferrate (III)

In  $[\text{FeF}_6]^{3-}$  coordination no. of Fe = 6

In  $[\text{FeF}_6]^{3-}$  oxidation state of Fe = + 3

$\therefore$  It has 5 unpaired electrons,  $n = 5$ ,  $\text{Fe}^{3+}$  is  $3d^5$

Magnetic moment ( $\mu$ ) =  $\sqrt{n(n+2)}$  (B.M.)

$$\sqrt{5(5+2)} = \sqrt{35} = 5.92 \text{ B.M.}$$

30. Reaction involved in developing of a black and white photographic film.

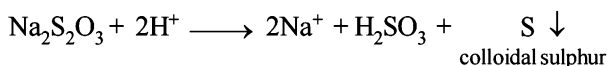
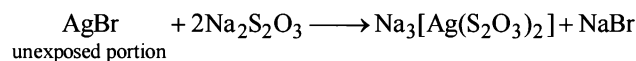
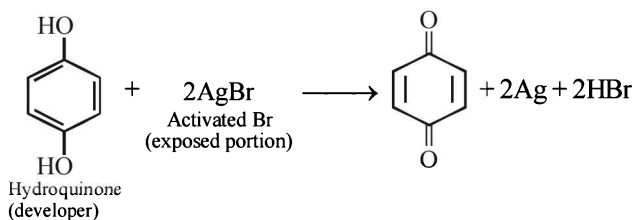

31.  $[\text{A}] = [\text{Ti}(\text{H}_2\text{O})_6]\text{Cl}_3$   $[\text{B}] = \text{HCl}$

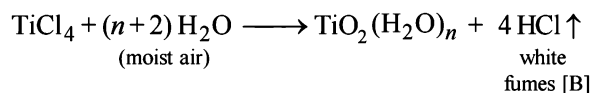
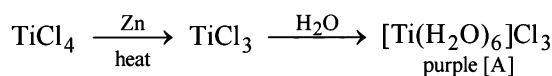

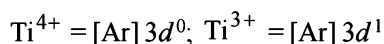

$\text{TiCl}_4$  is colourless since  $\text{Ti}^{4+}$  has no d electrons, hence *d-d* transition is impossible. On the other hand,  $\text{Ti}^{3+}$  is coloured due to *d-d* transition.  $\text{Ti}^{3+}$  absorbs greenish yellow compound of white light, hence its aqueous solution is purple which is complementary colour of greenish yellow in white light.

### F. Match the Following

#### 1. (A): (p), (q) and (s)

In  $[\text{Co}(\text{NH}_3)_4(\text{H}_2\text{O})_2]^{2+}$ , Co is in + 2 state having  $3d^7$  configuration, which makes it paramagnetic due to odd electrons. Moreover, it is an octahedral complex showing *cis-trans* isomerism w.r.t.,  $\text{H}_2\text{O}$ .

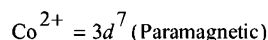
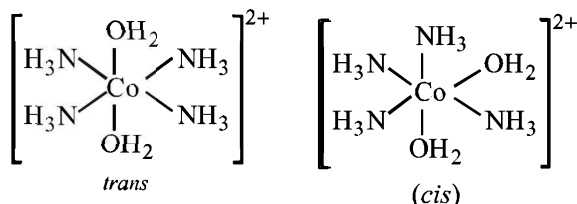

#### (B): (p), (r) and (s)

In  $[\text{Pt}(\text{NH}_3)\text{Cl}_2]$ , Pt is in + 2 state with configuration  $5d^8$ . Since  $\text{NH}_3$  is a strong field ligand, it will pair all the electrons making the complex diamagnetic. Moreover, it is a square planar complex showing *cis-trans* isomerism.

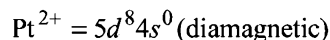
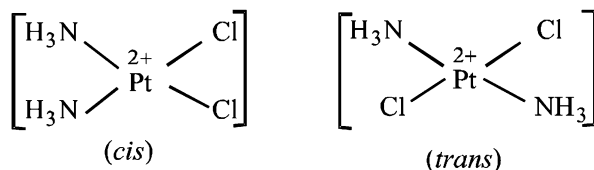

(C): (q) and (s) In  $[\text{Co}(\text{H}_2\text{O})_5\text{Cl}]\text{Cl}$ , Co is in + 2 state with  $3d^7$  configuration making it paramagnetic.

(D): (q) and (s) In  $[\text{Ni}(\text{H}_2\text{O})_6]\text{Cl}_2$ , Ni is in + 2 state with  $3d^8$  configuration. It is attached with weak field ligands, therefore it is paramagnetic.

#### 2. (A) -p, s; (B) -q, s; (C) -r, t; (D) -q, t

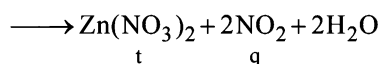
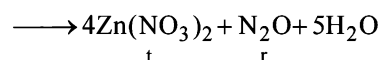
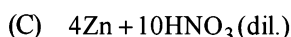
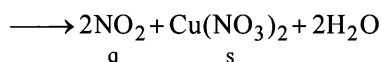
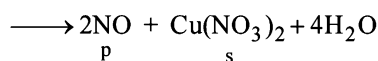
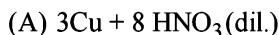

#### 3. (b)

Complex	Magnetic character	Isomerism
P, $[\text{Cr}(\text{NH}_3)_4\text{Cl}_2]\text{Cl}$	$\text{Cr}^{3+}$ is $d^3$ , hence paramagnetic	<i>cis-trans</i>
Q, $[\text{Ti}(\text{H}_2\text{O})_5\text{Cl}](\text{NO}_3)_2$	$\text{Ti}^{3+}$ is $d^1$ , hence paramagnetic.	ionization
R, $[\text{Pt}(\text{en})(\text{NH}_3)\text{Cl}]\text{NO}_3$	$\text{Pt}^{2+}$ is $d^8$ , complex is square planar, all electrons are paired, hence diamagnetic	ionization
S, $[\text{Co}(\text{NH}_3)_4(\text{NO}_3)_2]\text{NO}_3$	$\text{Co}^{3+}$ is $d^6$ , all electrons are paired due to strong ligands, hence diamagnetic	<i>cis-trans</i>

### G. Comprehension Based Questions

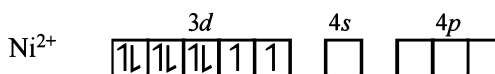
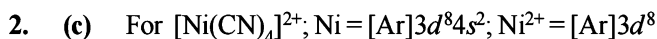

However,  $\text{CN}^-$  is a strong field ligand so it forces the 3d electrons to pair up and hence the effective configuration in this case will be

$\text{Ni}^{2+}$  in presence of  $\text{CN}^-$

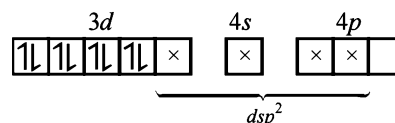

Thus  $[\text{Ni}(\text{CN})_4]^{2-}$  exhibits  $dsp^2$  hybridization and square planar shape. Since here number of unpaired electrons is zero the complex will be *diamagnetic*.

In case of  $[\text{NiCl}_4]^{2-}$ ,  $\text{Cl}^-$  is a weak field ligand, so the effective configuration of  $\text{Ni}^{2+}$  in this complex will be as follows :

$\text{Ni}^{2+}$  in presence of  $\text{Cl}^-$

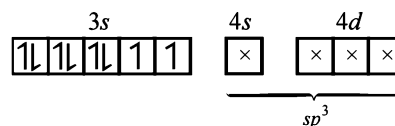

So here  $\text{Ni}^{2+}$  is  $sp^3$  hybridised and thus tetrahedral in shape. Since the complex has two unpaired electrons, it will be *paramagnetic*.

3. (a) Discussed above.

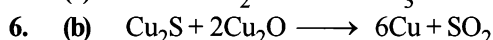
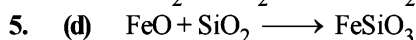
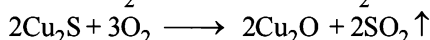
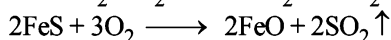
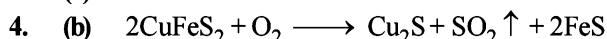

The reducing species is the one which gets oxidised. So, it is  $\text{S}^{2-}$  ion getting oxidised to  $\text{S}^{4+}$ .

7. (b) 8. (a)

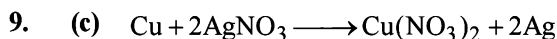

(M) (N) Blue





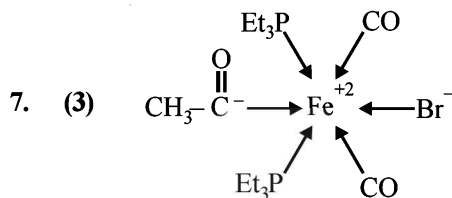
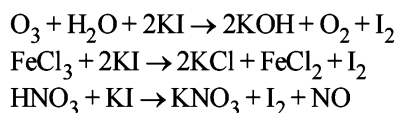

8. (6) All the complexes given show cis-trans isomerism  
 $[\text{Co}(\text{NH}_2-\text{CH}_2-\text{CH}_2-\text{NH}_2)_2\text{Cl}_2]^+ [\text{CrCl}_2(\text{C}_2\text{O}_4)_2]^{3-}$

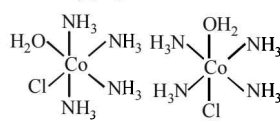
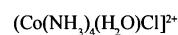
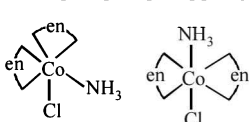
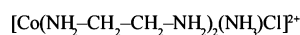
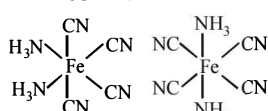
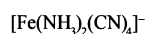
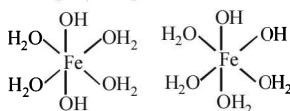
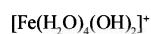
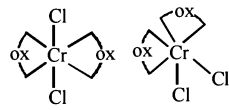
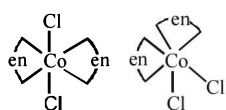

9. (4)  $\text{Fe}(26) \rightarrow [\text{Ar}]_{18} 3d^6 4s^2$

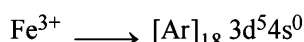

$\text{SCN}^-$  is weak field ligand hence pairing will not occur.

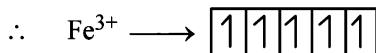

Unpaired electrons = 5

Magnetic moment =  $\sqrt{5(5+2)}$  B.M.

=  $\sqrt{35}$  B.M. = 5.92 B.M.

$\text{CN}^-$  is strong field ligand hence pairing will take place.

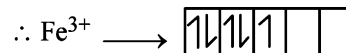

Unpaired electrons = 1

Magnetic moment =  $\sqrt{1(1+2)}$  B.M. =  $\sqrt{3}$  B.M. = 1.732

Difference = 5.92 - 1.732 = 4.188

Hence answer is (4).

10. (6)  $8\text{MnO}_4^- + 3\text{S}_2\text{O}_3^{2-} + \text{H}_2\text{O} \rightarrow$



$\therefore$  8 moles of  $\text{MnO}_4^-$  form 6 moles of  $\text{SO}_4^{2-}$

11. (5)  $[\text{CoL}_2\text{Cl}_2]^-$  (L =  $\text{H}_2\text{NCH}_2\text{CH}_2\text{O}^-$ )

L is unsymmetrical didentate ligand.

So the complete is equivalent to  $[\text{M}(\text{AB})_2\text{a}_2]$  Possible G.I. are

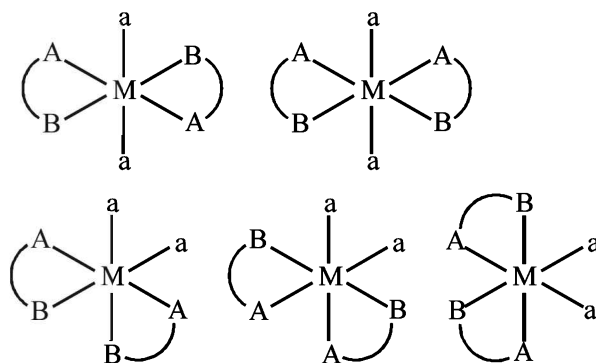

## Section-B JEE Main/ AIEEE

1. (b) A square planar complex is formed by hybridisation of  $s, p_x, p_y$  and  $d_{x^2-y^2}$  atomic orbitals

2. (b) The chemical formula of nitropentammine chromium (III) chloride is

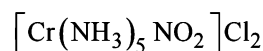

It can exist in following two structures

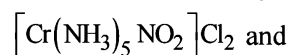

nitropentammine chromium (III) chloride

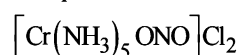

Nitropentammine chromium (III) chloride

Therefore the type of isomerism found in this compound is linkage isomerism as nitro group is linked through N as  $-\text{NO}_2$  or through O as  $-\text{ONO}$ .

3. (b) Compounds that contain at least one carbon metal bond are known as organometallic compounds. In  $\text{CH}_3\text{-Mg-Br}$  (Grignard's reagent) a bond is present

between carbon and Mg (Metal) hence it is an organometallic compound.

4. (c) Common oxidation states of Ce (Cerium) are +3 and +4

5. (a) In lanthanides there is a regular decrease in the atomic radii as well as ionic radii of trivalent ions as the atomic number increases from Ce to Lu. This decrease in size of atoms and ions is known as **lanthanide contraction**. Although the atomic radii do show some irregularities but ionic radii decreases from La to Lu. Thus the correct order is.

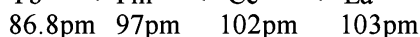
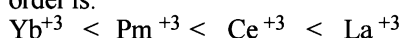

6. (a)  $\text{Mn}^{2+}$  - 5 unpaired electrons

$\text{Fe}^{2+}$  - 4 unpaired electrons

$\text{Ti}^{2+}$  - 2 unpaired electrons

$\text{Cr}^{2+}$  - 4 unpaired electrons

hence maximum no. of unpaired electron is present in  $\text{Mn}^{2+}$ .

**NOTE :** Magnetic moment  $\propto$  number of unpaired electrons

7. (c) The cyano and hydroxo complexes are far more stable than those formed by halide ion. This is due to the fact that  $\text{CN}^-$  and  $\text{OH}^-$  are strong Lewis bases (nucleophiles). Further  $[\text{Fe}(\text{OH})_5]^{3-}$  is not formed. Hence most stable ion is  $[\text{Fe}(\text{CN})_6]^{3-}$

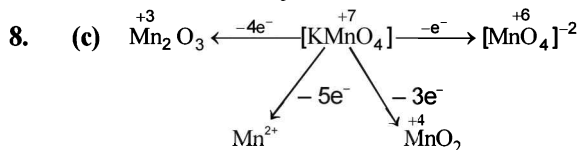

9. (c) Ionic radii  $\propto \frac{1}{Z}$

$$\text{Thus, } \frac{z_2}{z_1} \Rightarrow \frac{1.06}{(\text{Ionic radii of Lu}^{3+})} = \frac{71}{57}$$

$$\Rightarrow \text{Ionic radii of Lu}^{3+} = 0.85 \text{ \AA}$$

10. (a)  $\ddot{\text{N}}\text{H}_3 + \text{H}^+ (\text{acid medium}) \rightleftharpoons \overset{+}{\text{N}}\text{H}_4$

11. (d)  $\text{Co}(\text{NH}_3)_5\text{Cl}_3 \rightleftharpoons [\text{Co}(\text{NH}_3)_5\text{Cl}]^{+2} + 2\text{Cl}^-$   
 $\therefore$  Structure is  $[\text{Co}(\text{NH}_3)_5\text{Cl}]\text{Cl}_2$ .

Now  $[\text{Co}(\text{NH}_3)_5\text{Cl}]\text{Cl}_2 + 2\text{AgNO}_3$

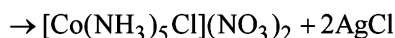

12. (a) Let the O. No of Ni in  $\text{K}_4[\text{Fe}(\text{CN})_6]$  be =  $x$  then  
 $4(+1) + x + (-1) \times 4 = 0 \Rightarrow 4 + x - 4 = 0$   
 $x = 0$

13. (a) When KI is added to mercuric iodide it dissolves in it and forms a complex.

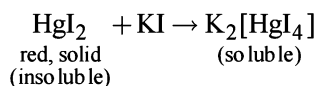

On heating  $\text{HgI}_2$  decomposes as

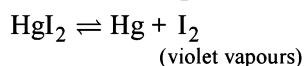

14. (b)  $f$ -block elements show a regular decrease in atomic size due to lanthanide/actinide contraction.

15. (a) When a solution of potassium chromate is treated with an excess of dilute nitric acid, potassium dichromate and  $\text{H}_2\text{O}$  are formed.

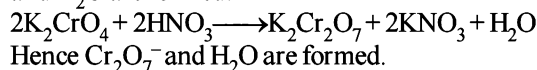

16. (c)  $\text{AgNO}_3$  on heating till red hot decomposes as follows:

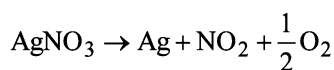

17. (d)  $(n-1)d^5ns^2$  attains the maximum O.S. of +7

18. (b) Grey tin  $\rightleftharpoons$  white tin

Grey tin is brittle and crumbles down to powder in very cold climate

The conversion of grey tin to white tin is accompanied by increase in volume. This is known as **tin plaque** or **tin disease**.

19. (a)  $\text{CN}^-$  ion acts as a good complexing as well as reducing agent.

20. (c) The coordination number of central metal atom in a complex is equal to the number of monovalent ligands, twice the number of bidentate ligands and so on, around the metal ion bonded by coordinate bonds. Hence coordination number = no. of  $\sigma$  bonds formed by metals with ligands

21. (d) Hybridisation

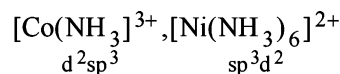
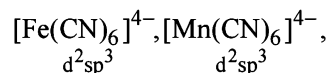

Hence  $[\text{Ni}(\text{NH}_3)_6]^{2+}$  is an outer orbital complex.

22. (c) The chlorophyll molecule plays an important role in photosynthesis, contains a porphyrin ring and the metal Mg not Ca.

23. (a) The +4 oxidation state of cerium is also known in solution.

24. (d) Isomers

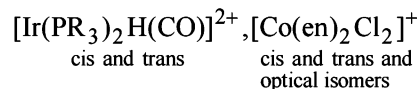
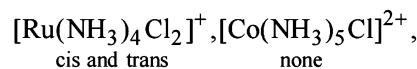

25. (c)  $[\text{Fe}(\text{CN})_6]^{4-} \rightarrow \boxed{\uparrow\downarrow}\boxed{\uparrow\downarrow}\boxed{\uparrow\downarrow} \boxed{:} \boxed{:} \boxed{:} \boxed{:}$   
 - no of unpaired electrons = 0

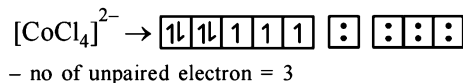
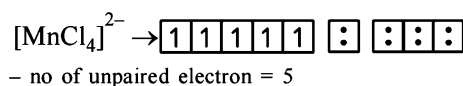

**NOTE :** The greater the number of unpaired electrons, the greater the magnitude of magnetic moment. Hence the correct order will be

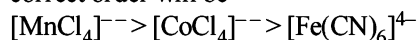

26. (d) Oxidation state of Cr in  $[\text{Cr}(\text{NH}_3)_4\text{Cl}_2]^+$ .

Let it be  $x$ ,  $1 \times x + 4 \times 0 + 2 \times (-1) = 1$  Therefore  $x = 3$ .

27. (d)  $2\text{Cu}_2\text{O} + \text{Cu}_2\text{S} \rightarrow 6\text{Cu} + \text{SO}_2$   
 self reduction.

28. (a)  $\text{Cr}_2\text{O}_7^{2-} + 6\text{I}^- + 14\text{H}^+ \rightarrow 3\text{I}_2 + 7\text{H}_2\text{O} + 2\text{Cr}^{3+}$   
 oxidation state of Cr is +3.

29. (d)  $\text{Hg}_2\text{Cl}_2 + 2\text{NH}_4\text{OH} \rightarrow \text{HgNH}_2\text{Cl} + \text{NH}_4\text{Cl} + 2\text{H}_2\text{O}$

30. (b) **NOTE :** In vertical columns of transition elements, there is an increase in size from the first member to the second member as expected but from the second member to the third member, there is a very small change in size and sometimes sizes are the same. This is due to lanthanide contraction. This is the reason for Zr and Hf to have the same radius.

31. (c)  $K_3[Fe(CN)_6]$  is potassium hexacyano ferrate (III).

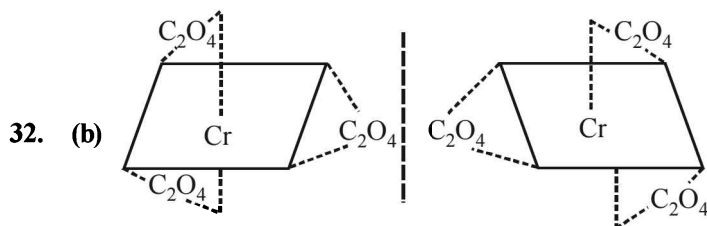

Non-superimposable mirror images, hence optical isomers.

33. (a)		No. of unpaired electron
a)	$Co^{3+}$	4
b)	$Fe^{3+}$	1
c)	$Mn^{3+}$	4
d)	$Cr^{3+}$	3

The effective magnetic moment is given by the number of unpaired electrons in a substance, the lesser the number of unpaired electrons lower is its magnetic moment in Bohr – Magnetron and lower shall be its paramagnetism

34. (d)  $d^5$  — strong ligand field



$$\mu = n\sqrt{n+2} = \sqrt{3} = 1.73\text{BM}$$

$d^3$  — in weak as well as in strong field



$$\mu = \sqrt{3(5)} = \sqrt{15} = 3.87\text{B.M.}$$

$d^4$  — in weak ligand field



$$\mu = \sqrt{4(8)} = \sqrt{24} = 4.89$$

$d^4$  — in strong ligand field



$$\mu = \sqrt{2(4)} = \sqrt{8} = 2.82.$$

35. (d) In lanthanides, there is poorer shielding of  $5d$  electrons by  $4f$  electrons resulting in greater attraction of the nucleus over  $5d$  electrons and contraction of the atomic radii.

36. (b)  $[Co(NO)_2(NH_3)_5]Cl_2$   
pentaammine nitrito-N-cobalt (III) chloride

37. (a) Metal atom in the lower oxidation state forms the ionic bond and in the higher oxidation state the covalent bond. because higher oxidation state means small size and great polarizing power and hence greater the covalent character. Hence  $MCl_2$  is more ionic than  $MCl_4$ .

38. (d)  $[NiX_4]^{2-}$ , the electronic configuration of  $Ni^{2+}$  is

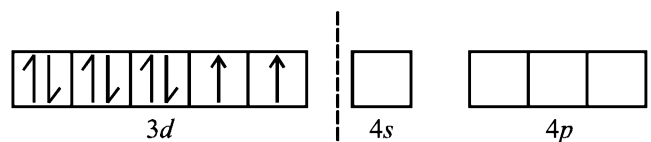

It contains two unpaired electrons and the hybridisation is  $sp^3$  (tetrahedral).

39. (d) Due to some backbonding by sidewise overlapping of between d-orbitals of metal and p-orbital of carbon, the Fe–C bond in  $Fe(CO)_5$  has both  $\sigma$  and  $\pi$  character.

40. (b) The configuration of Lanthanides show that the additional electron enters the  $4f$  subshell. The shielding of one  $4f$  electron by another is very little or imperfect. The imperfect shielding of  $f$  electrons is due to the shape of  $f$  orbitals which is very much diffused. Thus as the atomic number increases, the nuclear charge increases by unity at each step. While no comparable increase in the mutual shielding effect of  $4f$  occurs. This causes a contraction in the size of the  $4f$  subshell. as a result atomic and ionic radii decreases gradually from La to Lu.

41. (a) EDTA has hexadentate four donor O atoms and 2 donor N atoms and for the formation of octahedral complex one molecule is required

42. (c) The number of unpaired electrons in  $Ni^{2+}(aq) = 2$   
Water is weak ligand hence no pairing will take place  
spin magnetic moment =  $\sqrt{n(n+2)} = \sqrt{2(2+2)}$

$$= \sqrt{8} = 2.82$$

43. (d) Reluctance of valence shell electrons to participate in bonding is called inert pair effect. The stability of lower oxidation state (+2 for group 14 element) increases on going down the group. So the correct order is  $SiX_2 < GeX_2 < SnX_2 < PbX_2$

44. (a)  $4f$  orbital is nearer to nucleus as compared to  $5f$  orbital therefore, shielding of  $4f$  is more than  $5f$ .

45. (a) Complexes with  $dsp^2$  hybridisation are square planar. So  $[PtCl_4]^{2-}$  is square planar in shape.

46. (a) NOTE : More the distance between nucleus and outer orbitals, lesser will be force of attraction on them. Distance between nucleus and  $5f$  orbitals is more as compared to distance between  $4f$  orbital and nucleus. So actinoids exhibit more number of oxidation states in general than the lanthanoids.

47. (d) In the given complex we have two bidentate ligands (i.e en and  $C_2O_4$ ), so coordination number of E is 6 ( $2 \times 2 + 1 \times 2 = 6$ )

Let the oxidation state of E in complex be x, then

$$[x + (-2) = 1] \text{ or } x - 2 = 1$$

$$\text{or } x = +3, \text{ so its oxidation state is } +3$$

Thus option (d) is correct.

48. (b) NOTE : The main reason for exhibiting larger number of oxidation states by actinoids as compared to lanthanoids is lesser energy difference between  $5f$  and  $6d$  orbitals as compared to that between  $4f$  and  $5d$  orbitals.

In case of actinoids we can remove electrons from 5f as also from 6d and due to this actinoids exhibit larger number of oxidation state than lanthanoids. Thus the correct answer is option (b)

49. (a) In octahedral complex the magnitude of  $\Delta_o$  will be highest in a complex having strongest ligand. Of the given ligands  $\text{CN}^-$  is strongest so  $\Delta_o$  will be highest for  $(\text{Co}(\text{CN})_6)^{3-}$ . Thus option (a) is correct.
50. (c) The titration of oxalic acid with  $\text{KMnO}_4$  in presence of  $\text{HCl}$  gives unsatisfactory result because of the fact that  $\text{KMnO}_4$  can also oxidise  $\text{HCl}$  along with oxalic acid.  $\text{HCl}$  on oxidation gives  $\text{Cl}_2$  and  $\text{HCl}$  reduces  $\text{KMnO}_4$  to  $\text{Mn}^{2+}$  thus the correct answer is (c).

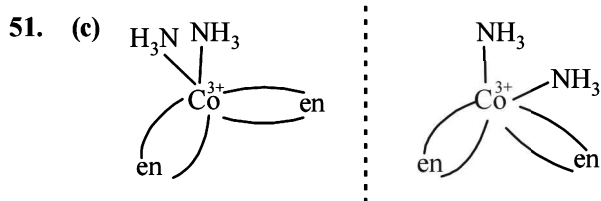

Enantiomers of  $\text{cis-}[\text{Co}(\text{en})_2(\text{NH}_3)_2]^{3+}$

52. (a) Lower oxidation state of an element forms more basic oxide and hydroxide, while the higher oxidation state will form more acidic oxide/hydroxide. For example,

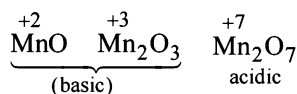

53. (a) The  $\text{SCN}^-$  ion can coordinate through S or N atom giving rise to linkage isomerism  
 $\text{M} \leftarrow \text{SCN}$  thiocyanato  
 $\text{M} \leftarrow \text{NCS}$  isothiocyanato.
54. (b) Most of the  $\text{Ln}^{3+}$  compounds except  $\text{La}^{3+}$  and  $\text{Lu}^{3+}$  are coloured due to the presence of  $f$ -electrons.
55. (a)  $\text{CoCl}_3 \cdot 6\text{NH}_3 \longrightarrow x\text{Cl}^-$

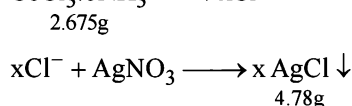

$$\text{Number of moles of the complex} = \frac{2.675}{267.5} = 0.01 \text{ moles}$$

$$\text{Number of moles of AgCl obtained} = \frac{4.78}{143.5} = 0.03 \text{ moles}$$

$\therefore$  No. of moles of  $\text{AgCl}$  obtained =  $3 \times$  No. of moles of complex

$$\therefore n = \frac{0.03}{0.01} = 3$$

56. (b) For a substance to be optical isomer following conditions should be fulfilled
- (a) A coordination compound which can rotate the plane of polarised light is said to be optically active.
- (b) When the coordination compounds have same formula but differ in their abilities to rotate directions of the plane of polarised light are said to exhibit optical isomerism and the molecules are optical isomers. The

optical isomers are pair of molecules which are non-superimposable mirror images of each other.

(c) This is due to the absence of elements of symmetry in the complex.

(d) Optical isomerism is expected in tetrahedral complexes of the type  $\text{Mabcd}$ .

Based on this only option (2) shows optical isomerism  $[\text{Co}(\text{en})_3]^{3+}$

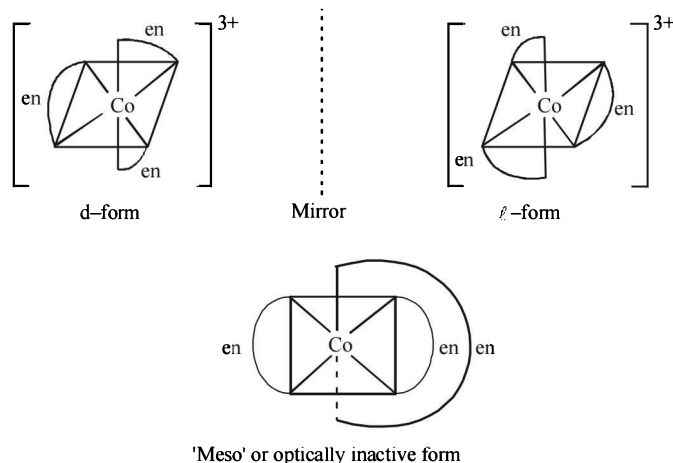

Complexes of  $\text{Zn}^{2+}$  cannot show optical isomerism as they are tetrahedral complexes with plane of symmetry.

$[\text{Co}(\text{H}_2\text{O})_4(\text{en})]^{3+}$  have two planes of symmetry hence it is also optically inactive.

57. (c) Hence the formula of the complex is  $[\text{Co}(\text{NH}_3)_6]\text{Cl}_3$   
 $[\text{Cr}(\text{NH}_3)_6]\text{Cl}_3$  is an inner orbital complex, because in this complex d-orbital used is of lower quantum number i.e.  $(n-1)$ . It results from  $d^2 sp^3$  (inner orbital) hybridization.

58. (d) The most stable oxidation states of lanthanides is +3.
59. (c)  $[\text{NiCl}_4]^{2-}$  ( $d^8$ )

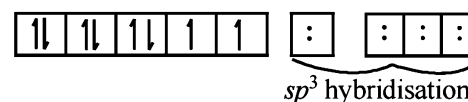

i.e. the number of unpaired electrons in  $[\text{NiCl}_4]^{2-}$  is 2.

$$n = \sqrt{n(n+2)} = \sqrt{2(4)} = 2\sqrt{2} = 2 \times 1.41 = 2.82 \text{ BM}$$

60. (d) The configuration of Gd is  $4f^7 5d^1 6s^2$ .
61. (b)  $[\text{Cr}(\text{en})_2\text{Br}_2]\text{Br}$  dibromidobis(ethylenediamine)chromium(III) Bromide.
62. (d)  $\text{Fe}^{3+}$  is easily hydrolysed than  $\text{Fe}^{2+}$  due to more positive charge.
63. (c) Octahedral coordination entities of the type  $\text{Ma}_3\text{b}_3$  exhibit Geometrical isomerism. The compound exists both as facial and meridional isomers.

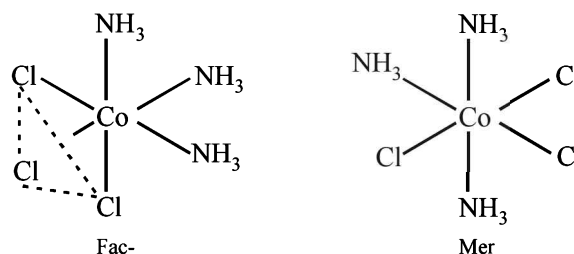

64. (a)

- (1)  $V = 3d^3 4s^2$      $V^{2+} = 3d^3 = 3$  unpaired electron  
 $Cr = 3d^5 4s^1$      $Cr^{2+} = 3d^4 = 4$  unpaired electron  
 $Mn = 3d^5 4s^2$      $Mn^{2+} = 3d^5 = 5$  unpaired electron  
 $Fe = 3d^6 4s^2$      $Fe^{2+} = 3d^6 = 4$  unpaired electron

hence the correct order of paramagnetic behaviour  
 $V^{2+} < Cr^{2+} = Fe^{2+} < Mn^{2+}$

- (2) For the same oxidation state, the ionic radii generally decreases as the atomic number increases in a particular transition series. hence the order is  
 $Mn^{++} > Fe^{++} > Co^{++} > Ni^{++}$

- (3) In solution, the stability of the compounds depends upon electrode potentials, SEP of the transition metal ions are given as

$$Co^{3+} / Co = +1.97, Fe^{3+} / Fe = +0.77;$$

$Cr^{3+} / Cr^{2+} = -0.41$ ,  $Sc^{3+}$  is highly stable as it does not show +2 O. S.

- (4) Sc-(+2), (+3)

Ti-(+2), (+3), (+4)

Cr-(+1), (+2), (+3), (+4), (+5), (+6)

Mn-(+2), (+3), (+4), (+5), (+6), (+7)

i.e.  $Sc < Ti < Cr = Mn$

$$E_a = 53598.6 \text{ J/mol} = 53.6 \text{ kJ/mol.}$$

65. (d)  $E^\circ_{Cr^{3+}/Cr^{2+}} = -0.41 \text{ V}$      $E^\circ_{Fe^{3+}/Fe^{2+}} = +0.77 \text{ V}$

$$E^\circ_{Mn^{3+}/Mn^{2+}} = +1.57 \text{ V}    E^\circ_{Co^{3+}/Co^{2+}} = +1.97 \text{ V}$$

66. (b)

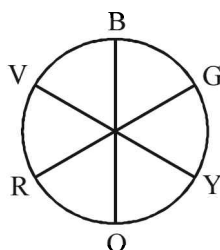

For a given metal ion, weak field ligands create a complex with smaller  $\Delta$ , which will absorb light of longer  $\lambda$  and thus lower frequency. Conversely, stronger field ligands create a larger  $\Delta$ , absorb light of shorter  $\lambda$  and thus higher  $\nu$  i.e. higher energy.

$$\text{Red} < \text{Yellow} < \text{Green} < \text{Blue}$$

$$\lambda = 650 \text{ nm} \quad 570 \text{ nm} \quad 490 \text{ nm} \quad 450 \text{ nm}$$

So order of ligand strength is

$$L_1 < L_3 < L_2 < L_4$$

67. (d) In equation (i)  $Fe_2(SO_4)_3$  and in equation (ii)  $Fe_2(SO_4)_3$  on decomposing will form oxide instead of Fe.

The correct sequence of reactions is

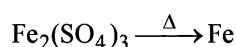
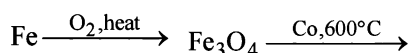

68. (c)

69. (d) (A) - (ii), (B) - (i), (C) - (iv), (D) - (iii)

70. (d) Square planar complexes of type  $M[ABCD]$  form three isomers. Their position may be obtained by fixing the position of one ligand and placing at the *trans* position any one of the remaining three ligands one by one.

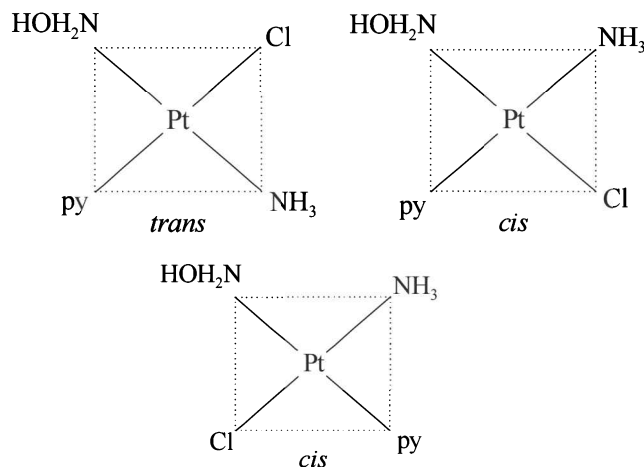

71. (a)  $L \rightarrow M$  charge transfer spectra.  $KMnO_4$  is colored because it absorbs light in the visible range of electromagnetic radiation. The permanganate ion is the source of color, as a ligand to metal, ( $L \rightarrow M$ ) charge transfer takes place between oxygen's  $p$  orbitals and the empty  $d$ -orbitals on the metal. This charge transfer takes place when a photon of light is absorbed, which leads to the purple color of the compound.

72. (d) Out of all the four given metallic oxides  $CrO_2$  is attracted by magnetic field very strongly. The effect persists even when the magnetic field is removed. Thus  $CrO_2$  is metallic and ferromagnetic in nature.

73. (c) Optical isomerism occurs when a molecule is non-superimposable with its mirror image hence the complex  $cis-[Co(en)_2Cl_2]Cl$  is optically active.

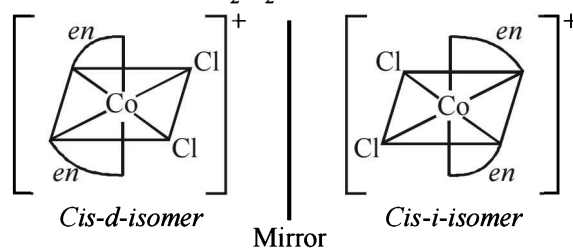

74. (d)

	Complex	Metal ion	Configuration	Magnetic moment $\mu = \sqrt{n(n+2)}$
(a)	$[Cr(H_2O)_6]^{2+}$	$Cr^{2+}$	$d^4$	$\sqrt{24}$
(b)	$[Fe(H_2O)_6]^{2+}$	$Fe^{2+}$	$d^6$	$\sqrt{24}$
(c)	$[CoCl_4]^{2-}$	$Co^{2+}$	$d^7$	$\sqrt{15}$
(d)	$[Mn(H_2O)_6]^{2+}$	$Mn^{2+}$	$d^5$	$\sqrt{35}$

Since (a) and (b), each has 4 unpaired electrons, they will have same magnetic moment.

## Section-A : JEE Advanced/ IIT-JEE

- A** 1. chlorine    2. Grignard    3. Thioalcohol    4. polyvinyl chloride  
**B** 1. F    2. F  
**C** 1. (d)    2. (d)    3. (a)    4. (b)    5. (b)    6. (a)    7. (b)  
 8. (b)    9. (a)    10. (d)    11. (b)    12. (d)    13. (d)    14. (a)  
 15. (b)    16. (a)  
**D** 1. (b, e)    2. (c)  
**E** 8.  $\text{CH}_2\text{Cl}$ ;  $\text{Y} : \text{CH}_2\text{ClCH}_2\text{Cl}$ ;  $\text{Z} : \text{CH}_3\text{CHCl}_2$

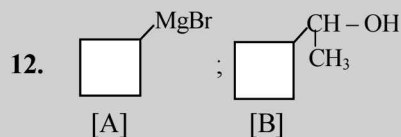
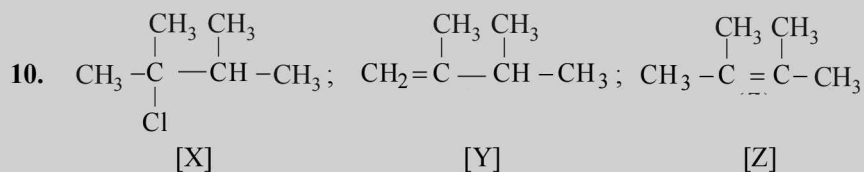
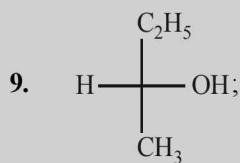

- H** 1. (c)  
**I** 1. 5    2. 5

## Section-B : JEE Main/ AIEEE

1. (d)    2. (b)    3. (b)    4. (b)    5. (c)    6. (d)    7. (d)  
 8. (a)    9. (b)    10. (c)    11. (d)    12. (a)    13. (c)    14. (d)  
 15. (d)    16. (b)    17. (c)    18. (b)

## Section-A JEE Advanced/ IIT-JEE

## A. Fill in the Blanks

1. **Chlorine**; because rate of formation of  $\cdot\text{CH}_3$  (one of the propagating steps) is high when  $\text{X}^\cdot$  is Cl.

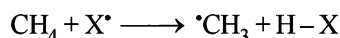

2. **Grignard (RMgX)**  
 3. **Thioalcohol**  
 4. **polyvinyl chloride.**

## B. True/False

1. **False** : *m*-Chlorobromobenzene and *m*-bromochlorobenzene is one and the same compound.

2. **False** :  $\text{CH}_2 = \text{CHCl} + \text{HI} \rightarrow \text{CH}_3\text{CHCl(I)}$   
 vinyl chloride                      1-chloro-1-iodoethane

This is an example of Markownikoff's rule as  $\text{I}^-$  is added at the C with less number. of H-atoms.

**NOTE** : *anti*-Markonikov's rule is applicable only to HBr, but not to HI and HCl.

## C. MCQs with One Correct Answer

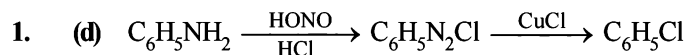

2. (d) **TIPS/Formulae :**

The given reaction is an example of electrophilic substitution. Further,  $\text{CH}_3$  group in toluene is *o*, *p*-directing

3. (a) Chlorination beyond monochlorination during the preparation of alkyl halides in presence of UV light can be suppressed by taking **alkane in excess**.

**NOTE :** For isomeric alkanes the one having largest straight chain has highest b.p. because of large surface area.

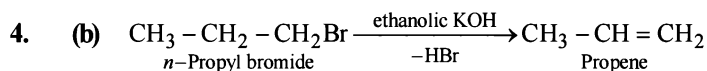

Further dehydrohalogenation of  $\text{CH}_3\text{CH} = \text{CH}_2$  can be done only by strong base like  $\text{NaNH}_2$ .

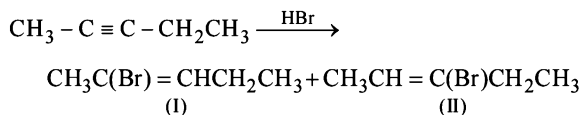
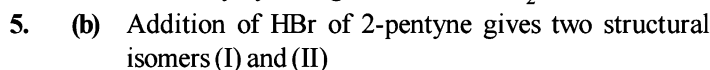

Each one of these will exist as a pair of geometrical isomers. Thus, there are two structural and four configurational isomers.

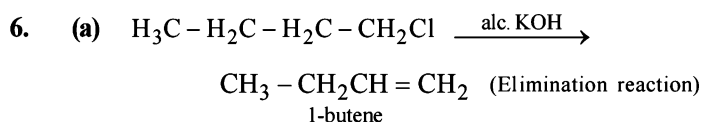

**NOTE :** Alkyl halides give alcohols with aq. KOH, which is a substitution reaction.



The reaction proceeds via free radical mechanism.

As 2° free radical is more stable than 1°, so  $\text{CH}_3\text{CH}_2\text{CH}(\text{Br})\text{CH}_3$  would be formed.

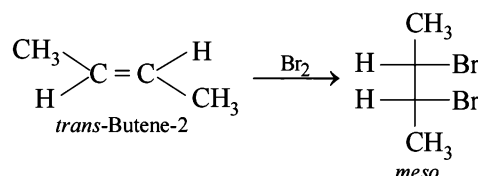
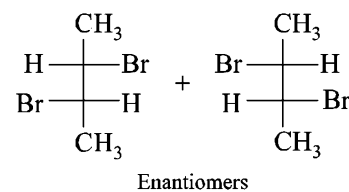
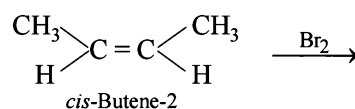
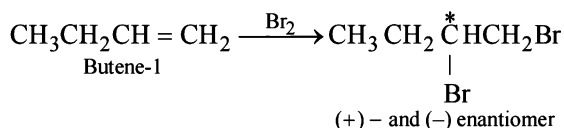
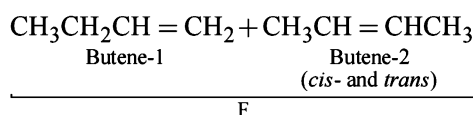
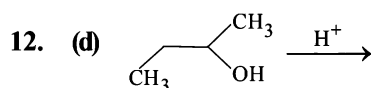
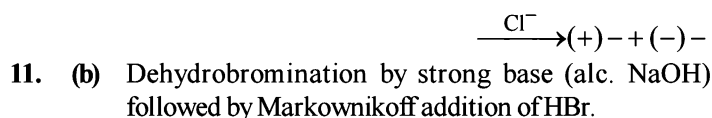
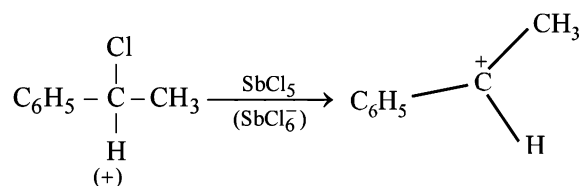
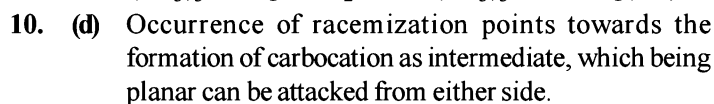
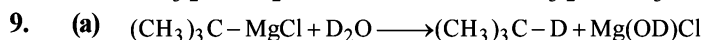

So F can have three possible structures



It is an example of intramolecular Wurtz reaction.

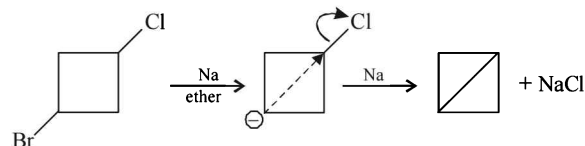

**NOTE :**  $\text{Br}^-$  is a better leaving group than chloride. In this reaction alkali metal (Na) is electron donor.

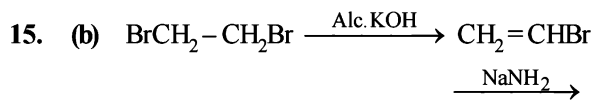
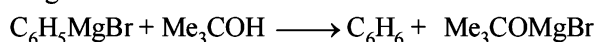
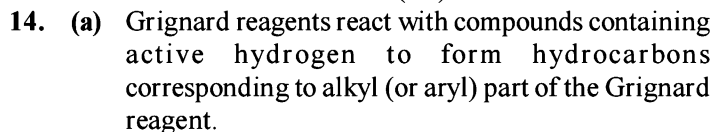

**NOTE :** Elimination of HBr from  $\text{CH}_2 = \text{CHBr}$  requires a stronger base because here, Br acquires partial double bond character due to resonance.

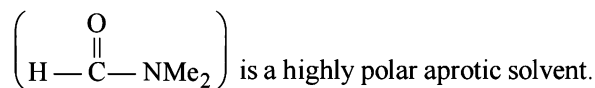
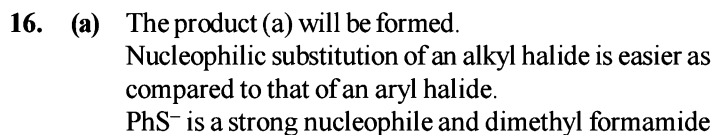

These reagent favour  $\text{S}_{\text{N}}2$  reactions at 2° benzylic carbon.

**NOTE :** In a  $\text{S}_{\text{N}}2$  reaction, the major product formed is inversion product.

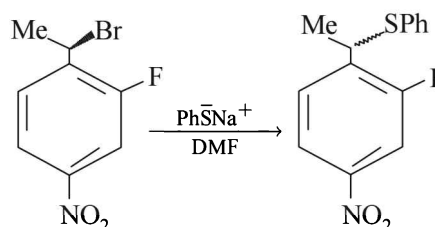

### D. MCQs with One or More Than One Correct

#### 1. (b, e) TIPS/Formulae :

Aryl halides are stable due to resonance stabilization.

The resonating structures

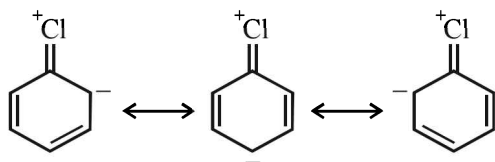

stabilise the aryl halide. These structures include a double bond between C and Cl which is shorter and thus stronger than the usual C-Cl single bond. The  $sp^2$  hybridised carbon, being electronegative, makes the C-Cl bond shorter and stronger.

2. (c) Chlorination of toluene to form benzyl chloride is a free radical substitution reaction; only  $Cl_2$  can give  $\dot{C}l$  in presence of light.

#### E. Subjective Problems

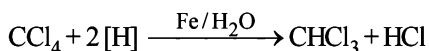
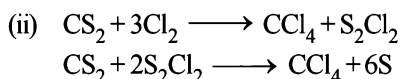
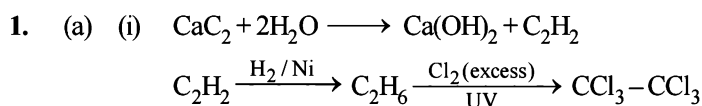

(b) Carbylamine test.

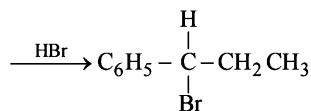
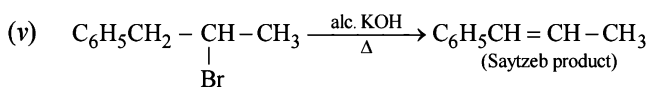
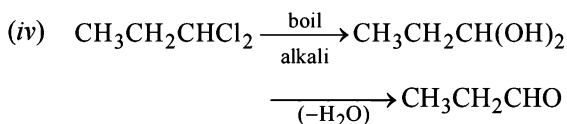
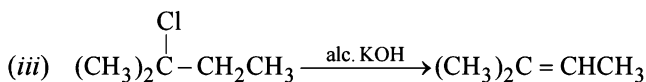
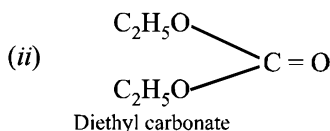
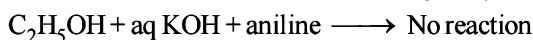
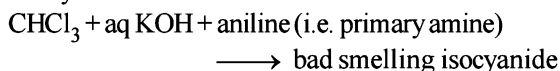

[NOTE :  $C_6H_5CH_2\overset{+}{C}HCH_3$  and  $C_6H_5\overset{+}{C}HCH_2CH_3$  carbocations are formed on addition of HBr on  $C_6H_5CH=CHCH_3$ , the latter being benzylic carbocation, is stabilised due to resonance and hence  $Br^-$  adds on it forming  $C_6H_5CHBr.CH_2CH_3$  as the final product.]

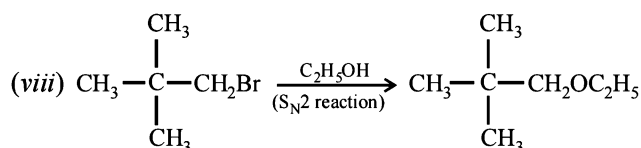
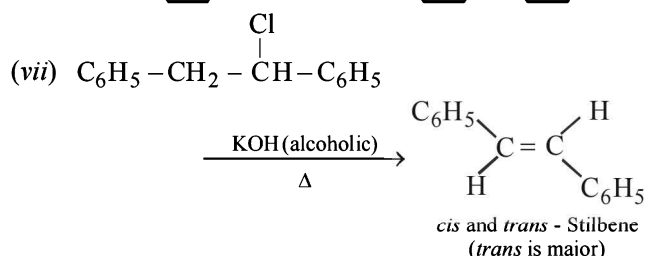
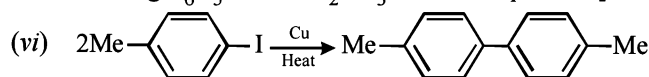

#### 3. (i) TIPS/Formulae :

7-Bromo-1,3,5-cycloheptatriene is aromatic whereas 5-Bromo-1,3-Cycloheptadiene is non aromatic.

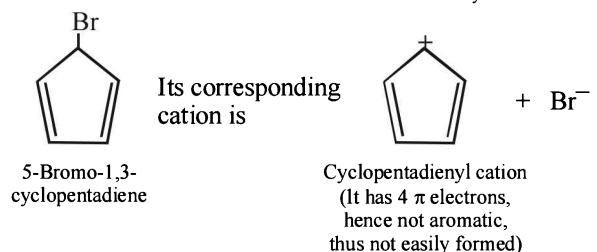
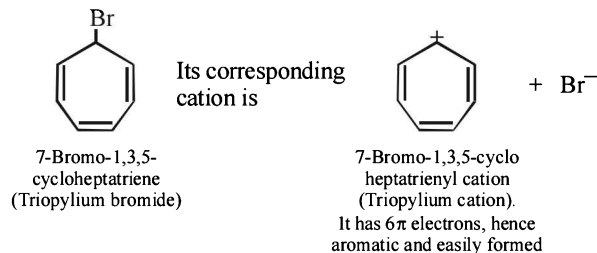

- (ii) NOTE : The former halide is a  $3^\circ$  halide, hence it undergoes  $S_N1$  reaction forming HBr, as one of the products, which make solution acidic.

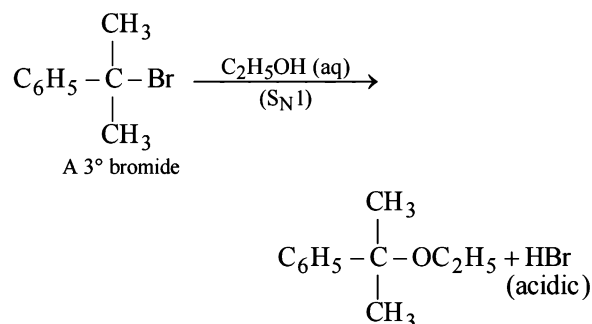

$Br-\text{C}_6\text{H}_4-\text{CH}(\text{CH}_3)_2$  is an aryl halide so it does not undergo nucleophilic substitution reactions. Hence the solution will remain neutral.



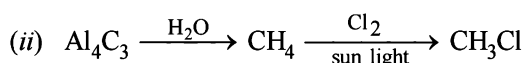
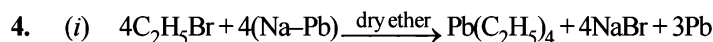

5. Dichloroethene exists in three isomeric forms.

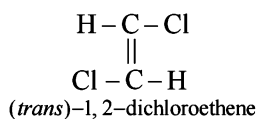
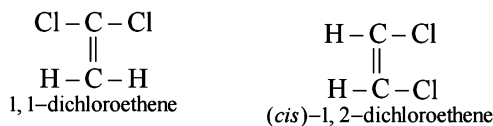

*trans*-1, 2-Dichloroethene has zero dipole moment.

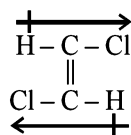

[NOTE : Dipole moment is a vector quantity]

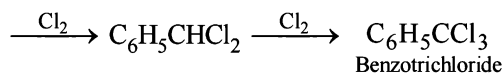
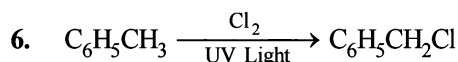

[NOTE : This follows free radical mechanism.]

7. **TIPS/Formulae :**

Resonance decreases the dipole moment of vinyl chloride ( $CH_2=CHCl$ ).

The positive charge on Cl and a negative charge on C (developed by resonance) oppose each other and hence diminish the electronegativity of Cl and thus polarity (and dipole moment) of the bond. The dipole moments of vinyl chloride and chlorobenzene are 1.4D and 1.7D respectively, while the dipole moment of alkyl halides is 2–2.2D.

8. % of Cl in X =  $\frac{35.5 \times 2.9}{143.5} \times 100 = 71.72\%$

Empirical formula of (X)

Element	%	Relative no. of atoms	Simplest ratio
C	24.24	2.02	1
H	4.04	4.04	2
Cl	71.72	2.02	1

∴ Empirical formula of (X) is  $CH_2Cl$

Since X has two isomers Y and Z, both react with KOH(aq).

Y  $\xrightarrow{KOH(aq)}$  dihydroxy compound *i.e.* 2Cl atoms on adjacent carbon

Z  $\xrightarrow{KOH(aq)}$   $CH_3CHO$  *i.e.* Z should have 2Cl atoms on one C atom

Thus Z should be  $CH_3CHCl_2$  (1, 1-dichloroethane) and Y should be  $CH_2ClCH_2Cl$  (1, 2-dichloroethane)

**Reactions :**

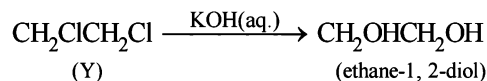
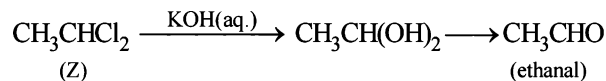

9.  $S_N2$  reaction leads to inversion in configuration.

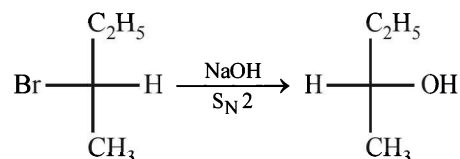

10. Summary of the given facts

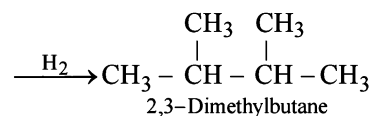
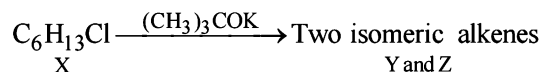

The two isomeric precursors (Y and Z) of 2, 3-dimethylbutane are



Hence the precursor of Y & Z should have following structure which explains all the given facts

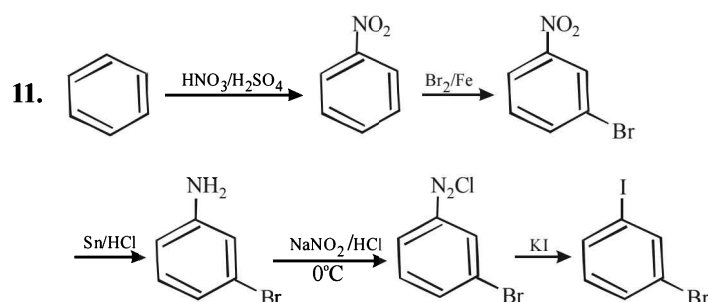
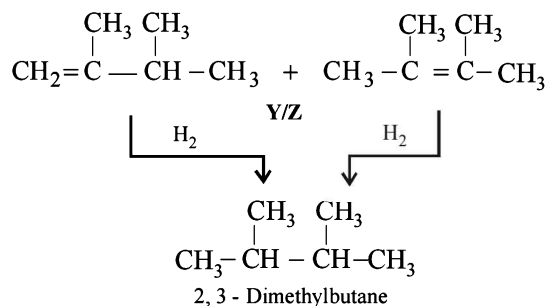
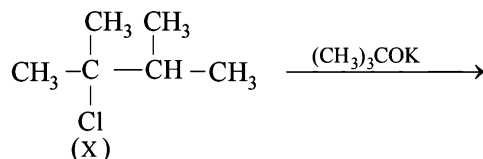

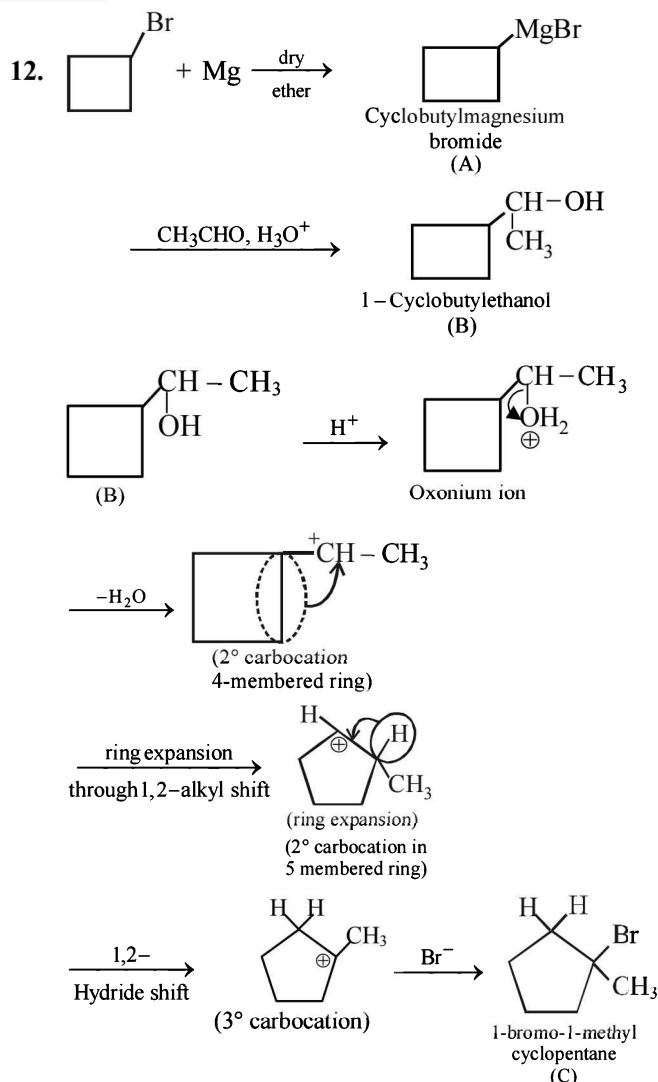

### H. Assertion & Reason Type Questions

1. (c) When halogen is present directly on the benzene nucleus it produces two opposing effects namely +M (activating effect) and -I (deactivating)

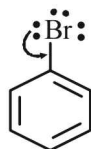

(-I effect, +M effect)

However, +M > -I hence halogens are said to be *o*, *p*-directing (due to +M effect) but deactivating group (due to -I effect) groups giving mainly *p*-substituted product.

### I. Integer Value Correct Type

1. 5  
Total no. of alkenes will be = 5

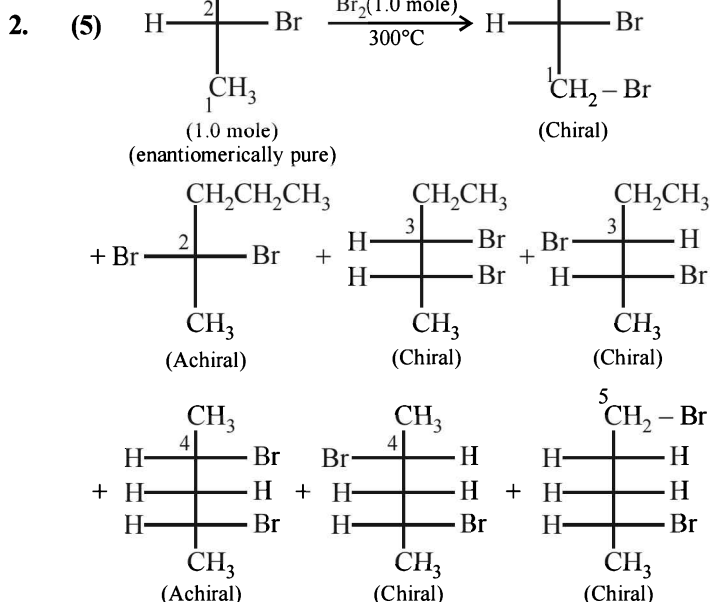
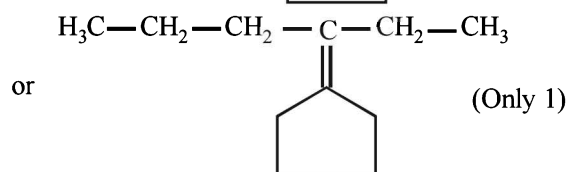
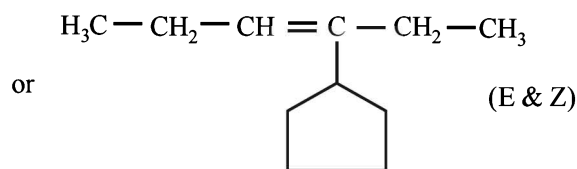
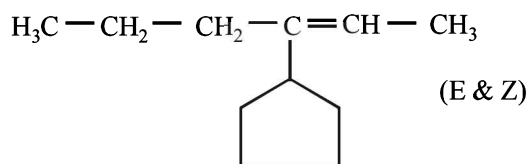
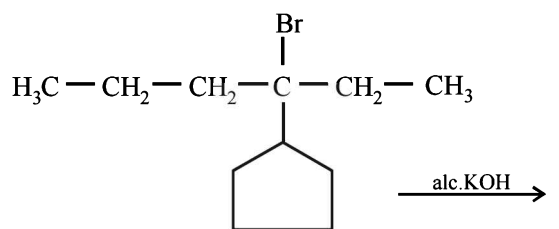

## Section-B JEE Main/AIEEE

1. (d)  $C_6H_5I \xrightarrow{NaOH} C_6H_5ONa \xrightarrow{HNO_3/H^+}$   
 $C_6H_5OH \xrightarrow{AgNO_3} \text{No yellow ppt.}$   
 $C_6H_5CH_2I \xrightarrow{NaOH} C_6H_5CH_2ONa \xrightarrow{HNO_3/H^+}$

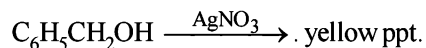

Since benzyl iodide gives yellow ppt. hence this is compound B and A was phenyl iodide ( $C_6H_5I$ ).

2. (b) DDT is prepared by heating chlorobenzene and chloral with concentrated sulphuric acid

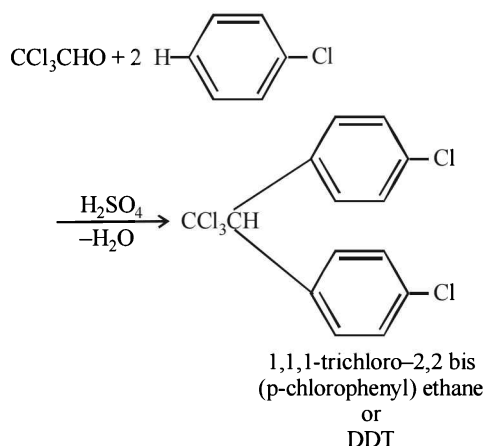

3. (b) Due to steric hindrance tertiary alkyl halide do not react by  $\text{S}_{\text{N}}2$  mechanism they react by  $\text{S}_{\text{N}}1$  mechanism.  $\text{S}_{\text{N}}2$  mechanism is followed in case of primary and secondary alkyl halides

The order is

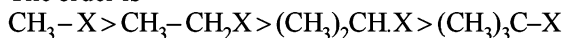

4. (b) In Corey House synthesis of alkanes alkyl halide react with lithium dialkyl cuprate

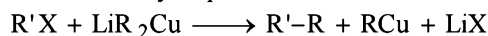

5. (c)  $\text{CH}_3-\overset{\text{Br}}{\text{CH}}-\text{CH}_2-\text{CH}_3 \xrightarrow{\text{alc. KOH}} \text{CH}_3-\text{CH}=\text{CH}-\text{CH}_3 + \text{HBr}$   
The formation of 2-butene is in accordance to **Saytzeff's rule**. The more substituted alkene is formed.

6. (d)  $\text{CH}_3\text{OH} + \text{C}_6\text{H}_5\text{MgBr} \longrightarrow \text{CH}_3\text{O}^-\text{Mg}^+\text{Br} + \text{C}_6\text{H}_6$

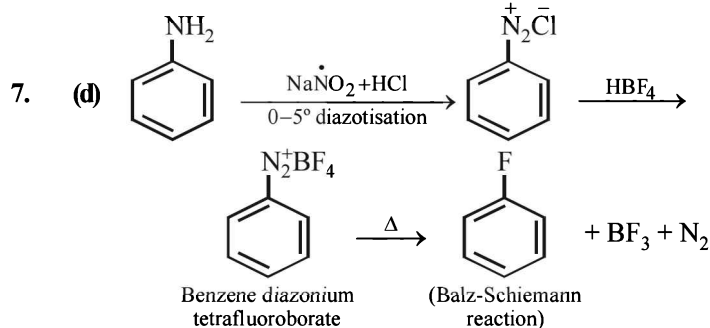

8. (a) The reaction is dehydrohalogenation

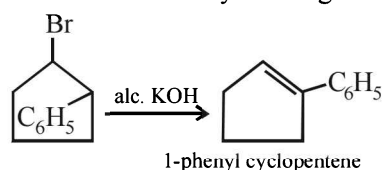

9. (b)
- Nuclear substitution will not take place.

10. (c) In  $\text{S}_{\text{N}}2$  mechanism transition state is pentavalent. For bulky alkyl group it will have sterical hindrance and smaller alkyl group will favour the  $\text{S}_{\text{N}}2$  mechanism. So the decreasing order of reactivity of alkyl halides is  $\text{RCH}_2\text{X} > \text{R}_2\text{CHX} > \text{R}_3\text{CX}$

11. (d)  $\text{S}_{\text{N}}2$  reaction is favoured by small groups on the carbon atom attached to halogen.

So, the order of reactivity is

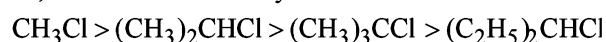

**NOTE :**  $\text{S}_{\text{N}}2$  reaction is shown to maximum extent by primary halides. The only primary halides given is  $\text{CH}_3\text{Cl}$  so the correct answer is (d).

12. (a)

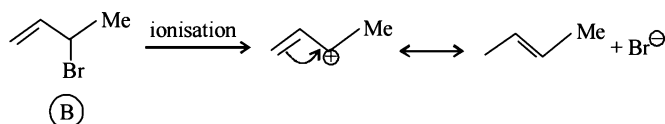
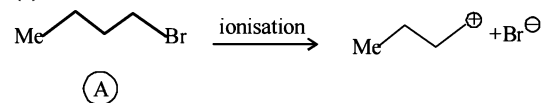

Since  $\text{S}_{\text{N}}1$  reactions involve the formation of carbocation as intermediate in the rate determining step, **more is the stability of carbocation higher will be reactivity of alkyl halides towards  $\text{S}_{\text{N}}1$  route**. Now we know that stability of carbocations follows the order :  $3^\circ > 2^\circ > 1^\circ$ , so  $\text{S}_{\text{N}}1$  reactivity should also follow the same order.

$3^\circ > 2^\circ > 1^\circ > \text{Methyl (S}_{\text{N}}1 \text{ reactivity)}$

13. (c)

14. (d) Four monochloro derivatives are chiral. DDT is a non-biodegradable pollutant.

15. (d)

16. (b) Steric congestion around the carbon atom undergoing the inversion process will slow down the  $\text{S}_{\text{N}}2$  reaction, hence less congestion faster will the reaction. So, the order is  $\text{CH}_3\text{Cl} > (\text{CH}_3)_2\text{CHCl} > (\text{CH}_3)_3\text{CCl}$

17. (c)  $2\text{Cl}-\overset{\text{Cl}}{\underset{\text{Cl}}{\text{C}}}-\text{CH}_3 + 6\text{Ag} \longrightarrow \text{CH}_3\text{C}\equiv\text{CCH}_3 + 6\text{AgCl}$

1, 1, 1-trichloroethane 2-butyne

18. (b) Alkyl fluorides are more conveniently prepared by heating suitable chloro- or bromo-alkanes with organic fluorides such as  $\text{AsF}_3$ ,  $\text{SbF}_3$ ,  $\text{CoF}_2$ ,  $\text{AgF}$ ,  $\text{Hg}_2\text{F}_2$  etc. This reaction is called **Swarts reaction**.

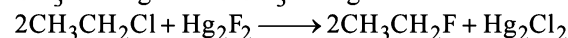
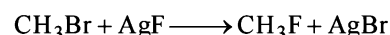

# Alcohols, Phenols and Ethers

## Section-A : JEE Advanced/ IIT-JEE

- A** 1. aldol ( $\beta$ -hydroxybutanal)      2. resonance stabilization      3. nucleophilic      4. phenoxide ion  
5. peroxides      6. secondary

**B** 1. F

- C** 1. (c)      2. (a)      3. (d)      4. (b)      5. (c)      6. (a)      7. (d)  
8. (a)      9. (c)      10. (b)      11. (d)      12. (d)      13. (a)      14. (c)  
15. (b)      16. (c)      17. (b)      18. (d)      19. (d)      20. (d)      21. (c)

- D** 1. (b)      2. (a, d)      3. (a, c)      4. (b)      5. (a, c, d)      6. (a, b, c)      7. (b)

- E** 1. A is  $C_2H_5OH$  and B is  $C_2H_4$       2.  $C_2H_5OC_2H_5, C_2H_5I, C_2H_5OH$   
X      Y      Z      A

7. *m*-cresol

10.  $HC \equiv C.CH_2.CH_2.CH_2OH$

11. *n*-butanol,  $MnO_2$

14.  $C_6H_5CH(OH)CH_3, C_6H_5COOH$       15.  $CH \equiv C - \overset{\overset{CH_3}{|}}{C} - OH; CH_3CH_2 - \overset{\overset{CH_3}{|}}{C} - OH$   
D      E      A      B

21.  $CH_3CH_2CH_2CH = CH - CH = CH.(CH_2)_8.CH_2OH$  (Bombykol)

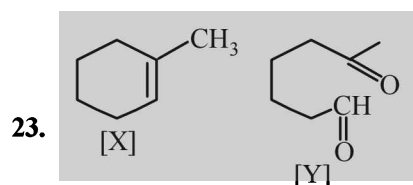

**F** 1. (a)

- G** 1. (c)      2. (c)      3. (b)      4. (b)      5. (a)      6. (d)

**H** 1. (c)

- I** 1. 9      2. 4

## Section-B : JEE Main/ AIEEE

1. (d)      2. (a)      3. (a)      4. (c)      5. (b)      6. (b)  
7. (c)      8. (d)      9. (d)      10. (b)      11. (b)      12. (b)  
13. (a)      14. (d)      15. (c)      16. (b)      17. (a)      18. (a)  
19. (d)      20. (a)

# Section-A JEE Advanced/ IIT-JEE

## A. Fill in the Blanks

1. **aldol ( $\beta$ -hydroxybutanal);**

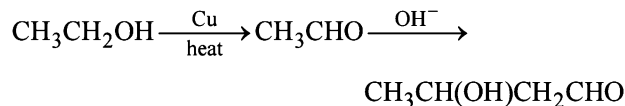

2. **resonance stabilization**

3. **nucleophilic**

4. **phenoxide ion**

5. **peroxides.** On standing in contact with air, ethers are converted into unstable peroxides ( $\text{R}_2\text{O} \rightarrow \text{O}$ ) which are highly explosive even in low concentrations. Hence ether is always purified before distillation. Purification (removal of peroxides) can be done by washing ether with a solution of ferrous salt (which reduces peroxides to alcohols) or by distillation with conc.  $\text{H}_2\text{SO}_4$  (which oxidises peroxides)

6. **Secondary.**

## B. True / False

1. **False :** Ethanol is not acidic enough to react with aq. NaOH. Thus sod. ethoxide ( $\text{C}_2\text{H}_5\text{ONa}$ ) is prepared by the reaction of Na metal with ethyl alcohol.

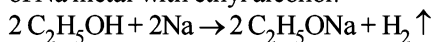

## C. MCQs with ONE Correct Answer

1. (c)  $2\text{C}_2\text{H}_5\text{OH} \xrightarrow[\Delta]{\text{H}_2\text{SO}_4} \text{C}_2\text{H}_4 + \text{H}_2\text{O}$

2. (a)

3. (d) **TIPS/Formulae :**

The order of reactivity of alcohol with Lucas reagent is *tert.* > *sec.* > *pri.*

**Lucas test** is based on the difference in the three types of alcohols (having 6 or less carbon) towards **Lucas reagent** (a mixture of conc. hydrochloric acid and anhydrous zinc chloride) at room temperature.

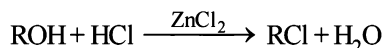

The tertiary alcohols produce turbidity immediately, the secondary alcohols give turbidity within 5 – 10 minutes, and the primary alcohols do not give turbidity at all, at room temperature.

Hence 2-methylpropan-2-ol (a  $3^\circ$  alcohol) reacts fastest.

4. (b) **TIPS/Formulae :**

Compounds having  $-\overset{\text{O}}{\parallel}{\text{C}}-\text{CH}_3$  groups show positive

iodoform test.

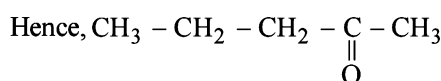

(pentanone-2) gives this test.

5. (c)  $\text{C}_2\text{H}_5\text{OC}_2\text{H}_5 + 2\text{HI} \xrightarrow{\Delta} 2\text{C}_2\text{H}_5\text{I} + \text{H}_2\text{O}$

6. (a)  $\underbrace{\text{CO} + \text{H}_2}_{\text{water gas}} + \text{H}_2 \xrightarrow[300^\circ\text{C}]{\text{Cr}_2\text{O}_3 - \text{ZnO}} \text{CH}_3\text{OH}$   
Methanol

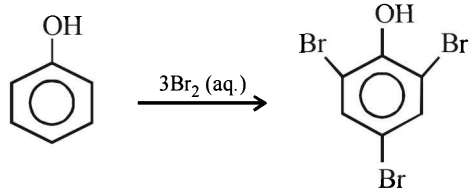
7. (d)    
2, 4, 6-Tribromophenol

## NOTE:

The  $-\text{OH}$  group in phenol, being activating group, facilitates substitution in the *o*- and *p*-positions.

8. (a) Reactions involving cleavage of carbon-oxygen bond, ( $\text{C}-\text{OH}$ ) follows the following order :  
Tertiary > Secondary > Primary

9. (c) **TIPS/Formulae :**

Secondary alcohols oxidise to produce ketone.

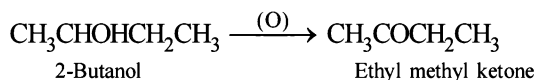

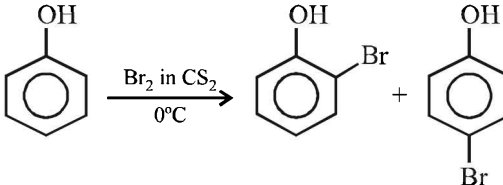
10. (b) 

**NOTE :** In absence of  $\text{CS}_2$ , polyhalogenation in *o*- and *p*-positions takes place.

11. (d)  $\text{C}_6\text{H}_5\text{CH}_3 + \text{Cl}_2(\text{exc.}) \xrightarrow{\text{light, heat}} \text{C}_6\text{H}_5\text{CCl}_3$

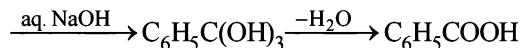

12. (d) **TIPS/Formulae :**

Riemer-Tiemann reaction involves electrophilic substitution on the highly reactive phenoxide ring.

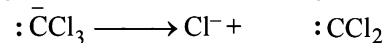
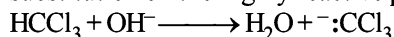

Note the C has only a sextet of electrons

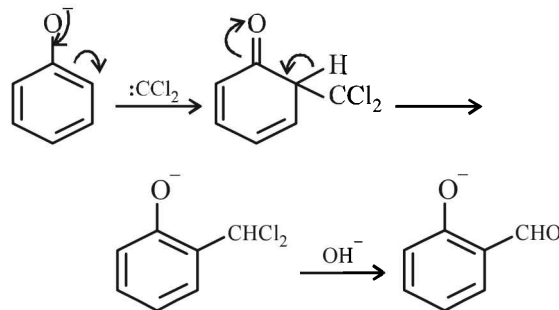

A benzal chloride

## 13. (a) TIPS/Formulae :

Compound  $(\text{CH}_3)_4\text{N}^+\text{I}^-$  is most reactive due to (i) better leaving group,  $\text{I}^-$  and (ii) due to the fact that the methyl group, with positive N, is more electron deficient. Hence this group is more reactive towards nucleophile,  $\text{OH}^-$

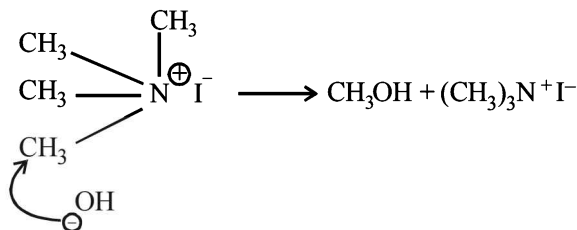

## 14. (c) NOTE:

Fehling solution is a weak oxidising agent which can oxidise aldehyde but not ketone.

Primary alcohols undergoes oxidation with alkaline  $\text{KMnO}_4$ , acidic dichromate and conc.  $\text{H}_2\text{SO}_4$  to give acids, whereas with Cu they give aldehydes.

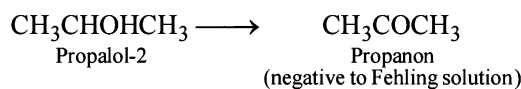
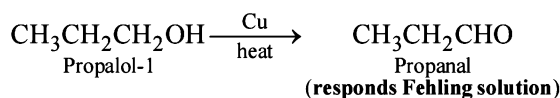

## 15. (b) NOTE : This reaction is an example of Williamson's synthesis.

$\text{C}_2\text{H}_5\text{O}^-$  will abstract proton from phenol converting the latter into phenoxide ion. This would then make nucleophilic attack on the methylene carbon of alkyl iodide forming  $\text{C}_6\text{H}_5\text{OC}_2\text{H}_5$ . But if  $\text{C}_2\text{H}_5\text{O}^-$  is in excess,  $\text{C}_2\text{H}_5\text{OC}_2\text{H}_5$  will be formed.  $\text{C}_2\text{H}_5\text{O}^-$  is a better nucleophile than  $\text{C}_6\text{H}_5\text{O}^-$  (phenoxide) ion because in the former the negative charge is localised over oxygen, while in the latter it is delocalised over the whole molecular framework. So, it is  $\text{C}_2\text{H}_5\text{O}^-$  ion that would make nucleophilic attack at ethyl iodide to give diethyl ether (Williamson's synthesis).

## 16. (c) NOTE : Addition of water to 2-phenylpropene follows Markownikov's rule.

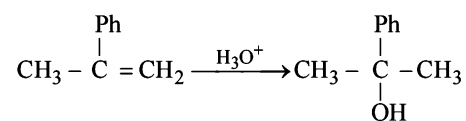

## 17. (b) TIPS/Formulae :

Conc. HCl, HBr and conc.  $\text{HCl} + \text{ZnCl}_2$  all are nucleophiles, thus convert alcohols to alkyl halides. However, conc.  $\text{H}_3\text{PO}_4$  is a good dehydrating agent which converts an alcohol to an alkene.

## 18. (d) Among the given compounds, hydroxybenzene (IV) has least molar mass and therefore possess least boiling point. Among the three isomeric dihydroxybenzenes, 1,2-dihydroxybenzene (I) forms intramolecular H-bonding with the result it will not form intermolecular

H-bonding leading to lowest boiling point. On the other hand 1,3-dihydroxybenzene (II) and 1,4-dihydroxybenzene (III) do not undergo chelation, hence they will involve extensive intermolecular H-bonding leading to higher boiling point. Further intermolecular hydrogen bonding is stronger in the *p*-isomer than the *m*-isomer hence former has highest b.p. Thus the decreasing order of boiling points is  $\text{III} > \text{II} > \text{I} > \text{IV}$ .

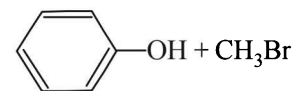
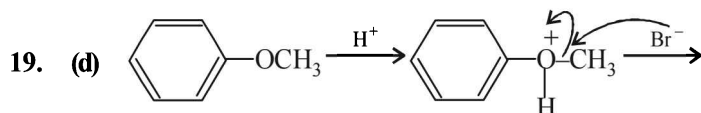
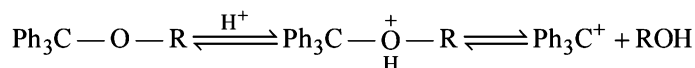
20. (d) In dye test, phenolic — OH group is converted to — O<sup>-</sup> which activates the ring towards electrophilic aromatic substitution21. (c) The given reaction proceeds through  $\text{S}_{\text{N}}1$  mechanism which involves carbocation as intermediate.

Thus, higher the stability of the carbocation, greater will be reactivity. Presence of electron releasing group (e.g.,  $-\text{OCH}_3$ ) in *p*-position of the phenyl group will disperse the positive charge of the carbocation by +M effect, hence stabilizes the carbocation.

## D. MCQs with ONE or More Than One Correct

## 1. (b) The mechanism of this reaction is represented as follows.

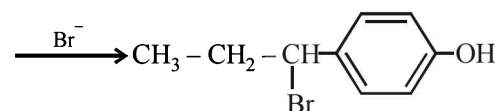
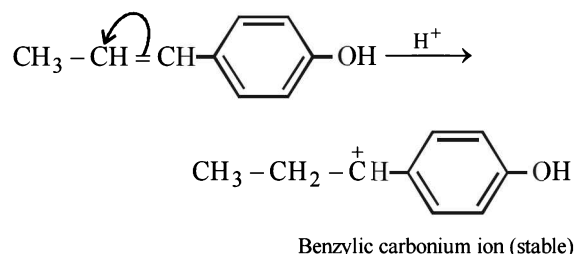

## 2. (a, d) TIPS/Formulae :

The aromatic ethers are cleaved to give phenol as one of the products.

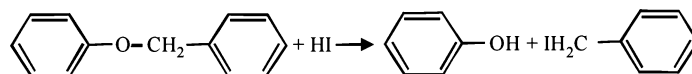

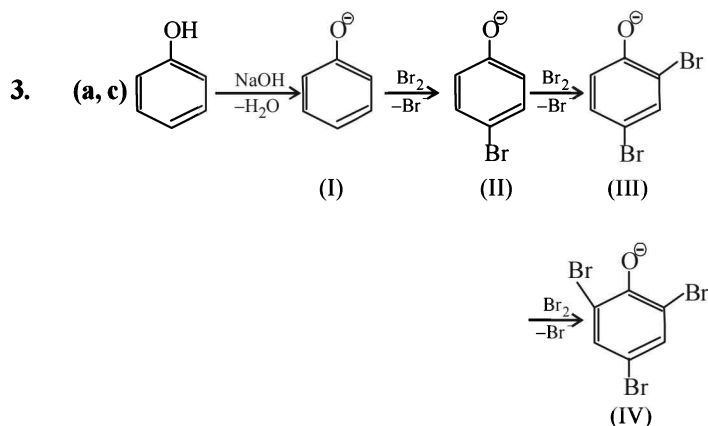

Product of reaction of phenol with NaOH/Br<sub>2</sub> is sodium salt of 2,4,6-tribromophenol. Hence, species (I), (II), (III) are formed as intermediate.

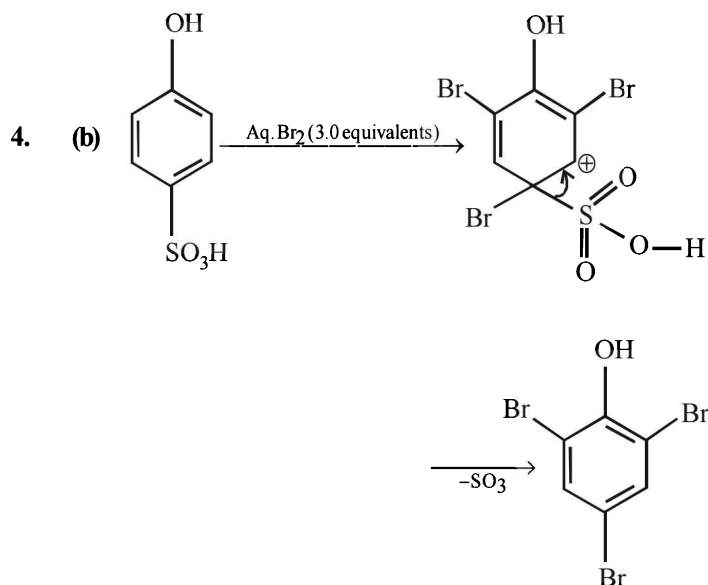

5. (a, c, d) Isomeric alcohols with molecular formula C<sub>4</sub>H<sub>10</sub>O are

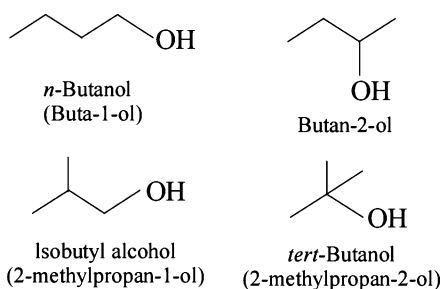

6. (a, b, c) —OH group is strongly activating and *o*, *p*-directing due to +M effect. Thus positions *a*, *b* and *c* are the sites for attack by an electrophile. However, sites *b* and *c* are not preferred by bulky electrophile due to steric crowding. Thus more bulky electrophile (like I<sub>2</sub>) can attack only site *a*, which is least sterically hindered, a bit smaller electrophile (Br<sub>2</sub>) can attack at sites *a* and also *b* (relatively less sterically hindered site) and the smallest electrophile (Cl<sub>2</sub>) can attack all the three sites,

viz., *a*, *b* and *c* (most sterically hindered site).

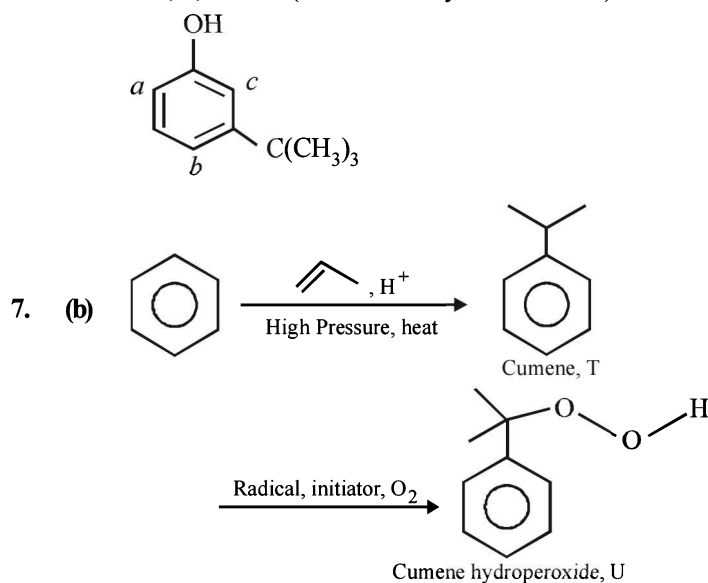

### E. Subjective Problems

1. 'A' is C<sub>2</sub>H<sub>5</sub>OH and 'B' is C<sub>2</sub>H<sub>4</sub>

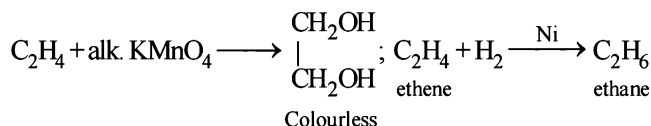
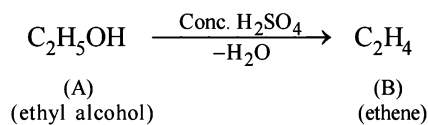

2. TIPS/Formulae :

The unreactivity of the compound (X) towards sodium indicates that it is neither an acid nor an alcohol, further its unreactivity towards Schiff's base indicates that it is not an aldehyde. The reaction of compound (X) with excess of HI to form only one product indicates that it should be an ether.

Hence its other reactions are sketched as below.

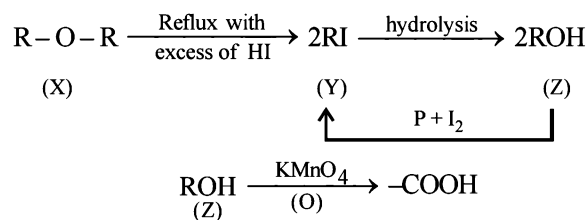

eq. wt. 60

Since the carboxylic acid has equivalent weight of 60, it must be acetic acid (CH<sub>3</sub>COOH), hence Z must be ethyl alcohol, (Y) ethyl iodide and (X) diethyl ether.

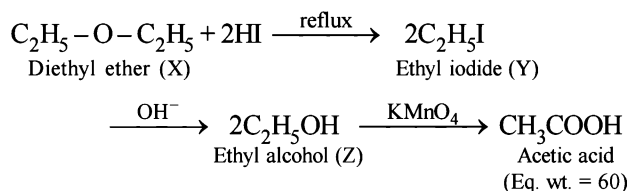

3. (i)  $\text{CH}_3\text{CH}(\text{OH})\text{CH}_3 \xrightarrow[\text{-H}_2\text{O}]{\text{Conc. H}_2\text{SO}_4} \text{CH}_3\text{CH}=\text{CH}_2$

2-propanol









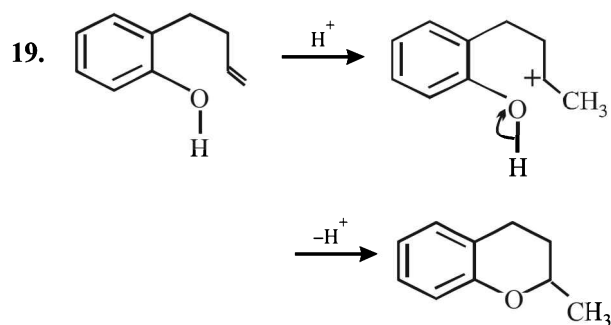

20. (i) **NOTE:**  
Since the large propenyl group is attached to the carbon atom bearing the hydroxyl group, so the reaction is likely to occur via  $S_N1$  mechanism.

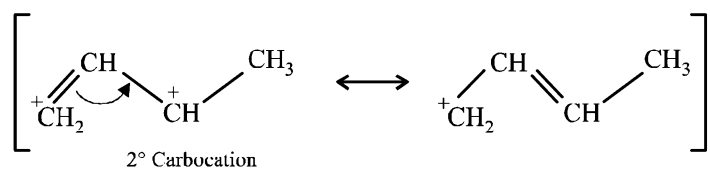
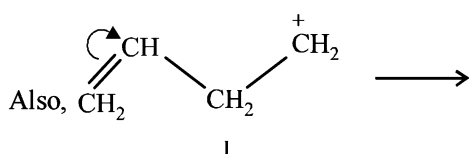
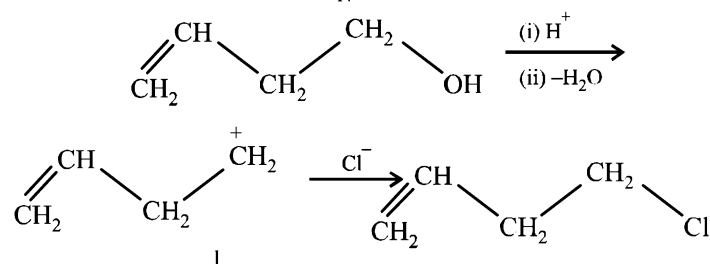

2° Carbocation

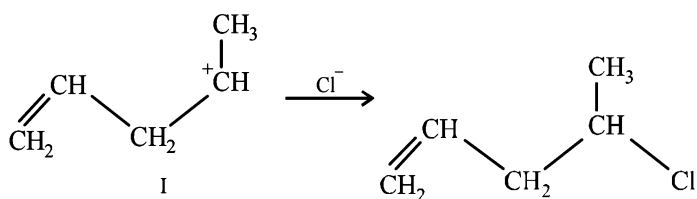
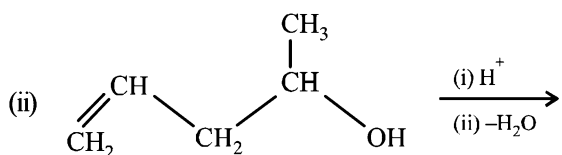
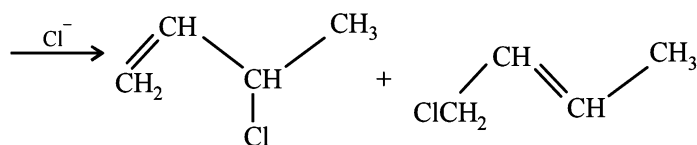

I' (2° Carbocation)

**NOTE:**

In the intermediate carbocation, I a carbon bearing positive charge has  $\text{CH}_3$  group which decreases the positive charge and hence prevents cyclisation of the compound.

## 21. TIPS/Formulae :

Let us summarise the given facts.

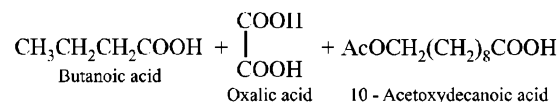
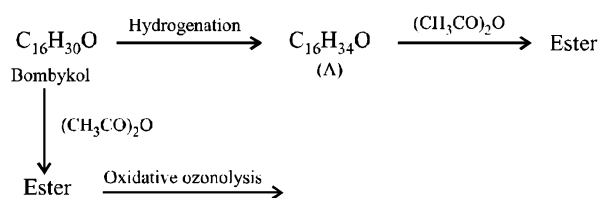

- (i) Hydrogenation of bombykol ( $\text{C}_{16}\text{H}_{30}\text{O}$ ) to  $\text{C}_{16}\text{H}_{34}\text{O}$  (A) indicates the presence of two double bonds in bombykol.  
(ii) Reaction of A with acetic anhydride to form ester indicates the presence of an alcoholic group in A and hence also in bombykol.  
(iii) Products of oxidative ozonolysis of bombykol ester suggests the structure of bombykol.

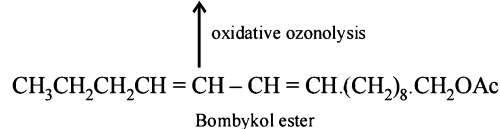
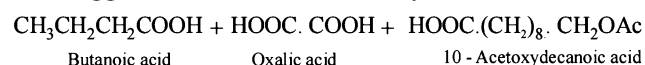

The structure of the bombykol ester suggests that bombykol has the following structure :

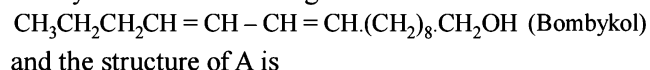

and the structure of A is  $\text{CH}_3\text{CH}_2\text{CH}_2\text{CH}_2\text{CH}_2\text{CH}_2\text{CH}_2(\text{CH}_2)_8\cdot\text{CH}_2\text{OH}$  or  $\text{C}_{16}\text{H}_{33}\text{OH}$ . Four geometrical isomers are possible for the above bombykol structure (as it has two double bonds).

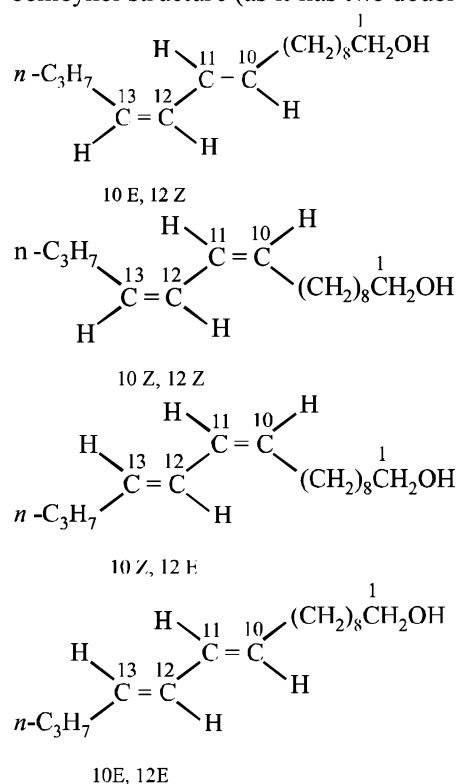

10E, 12E

22. (i) Molecular formula of P,  $C_5H_{10}O$  indicates  $1^\circ$  of unsaturation. So it should have double bond.

(ii) Acidic hydrolysis of P to Q and R, both of which responds iodoform test, indicates that Q and R should have following structure.



The only possible linkage that can explain such hydrolysis is ether. Hence P should have following type of structure.

$C_2$  - Component - O -  $C_3$  - Component

Further either the  $C_2$  - or the  $C_3$  - component should have double bond, thus the possible structure for P should be either of the following two structures which explains all the given reactions.

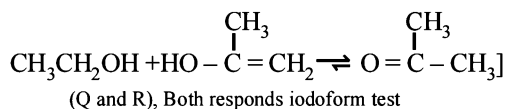
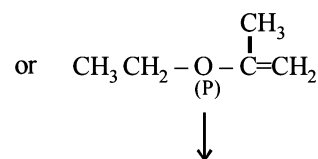
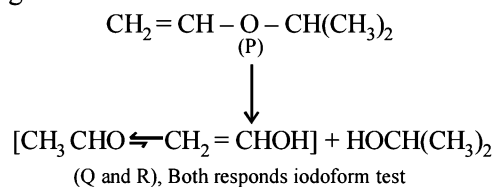

Extra reactivity of P toward dil.  $H_2SO_4$  than ethylene is due to formation of highly stable carbocation

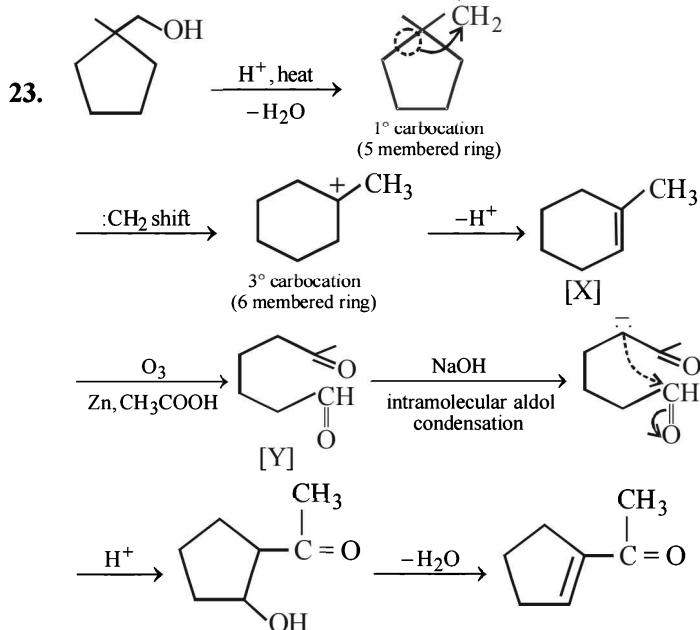
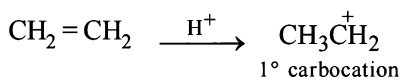
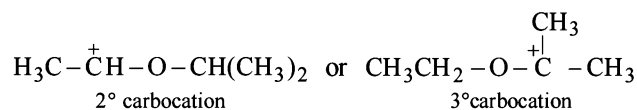

## F. Match the Following

1. (a)
- (P)
- (Q)
- (R)
- (S)
- (Antimarkovnikov addition)

## G. Comprehension Based Questions

1. (c) Reagents for Reimer - Tiemann reaction are aq.  $NaOH + CHCl_3$ .
2. (c)  $OH^- + CHCl_3 \rightleftharpoons :C^-Cl_3 + H_2O$   
 $CCl_3 \longrightarrow Cl^- + :CCl_2$  (Dichlorocarbene)
3. (b)

For 4-6. Before answering these question let us complete the sequence of reactions given in data.

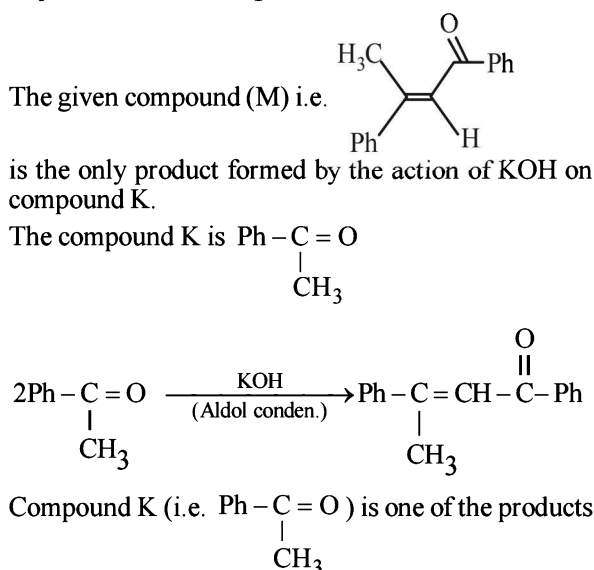

of ozonolysis of compound I. Therefore the compound I may be

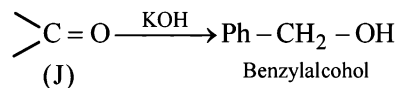
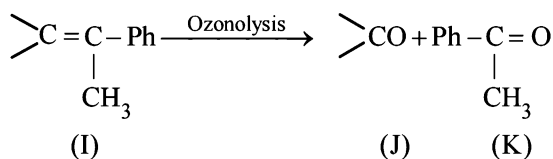

Thus J seems to be  $\text{C}_6\text{H}_5\text{CHO}$  and hence I is

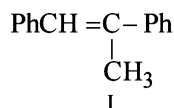

Now we will try to answer the questions.

4. (b) As can be seen from above reaction sequence compound (I) is  $\text{Ph-CH=C-Ph}$  and it is formed by

catalytic dehydration (acid catalysed) of a tertiary alcohol (compound H). Therefore compound H is

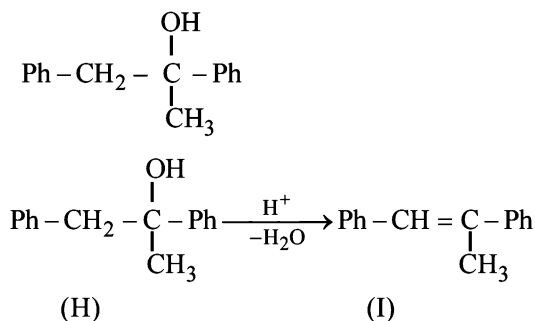

(H) can be formed by the action of  $\text{Ph-C(=O)-CH}_3$  with  $\text{PhCH}_2\text{MgBr}$  as follows

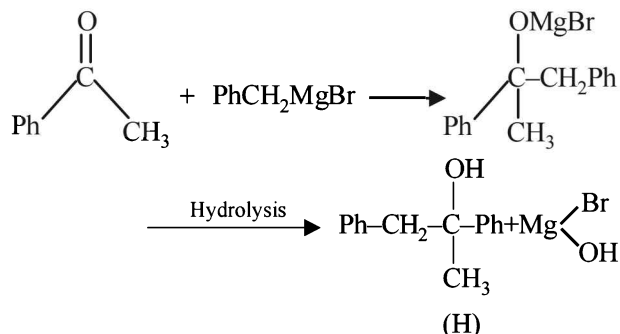

5. (a) Therefore the correct answer is option (b). As can be seen from the above sequence of reactions

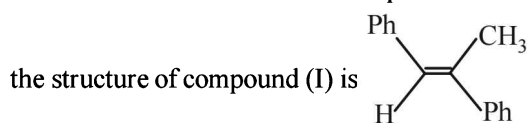

6. (d) Therefore the correct answer is option (a). As can be seen from the above sequence of reactions the structures of compounds J, K and L respectively are

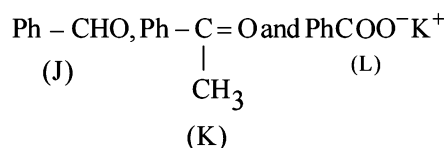

Thus the correct answer is option (d)

## H. Assertion & Reason Type Questions

1. (c) The solubility of alcohols in water can be explained due to the formation of hydrogen bond between the highly polarised  $-\text{OH}$  groups present both in alcohol and water. However, in higher alcohols the hydrocarbon character (alkyl chain) of the molecule increases and thus alcohols tend to resemble hydrocarbon (which are insoluble in water) and hence the solubility in water decreases. When the ratio of C to OH is more than 4, alcohols have little solubility in water. So statement is correct but explanation is not.

## I. Integer Value Correct Type

1. (9)

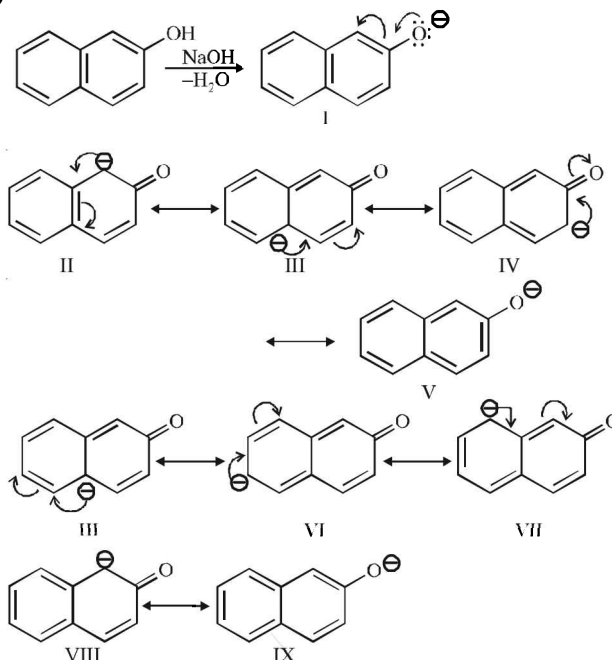

2. (4)

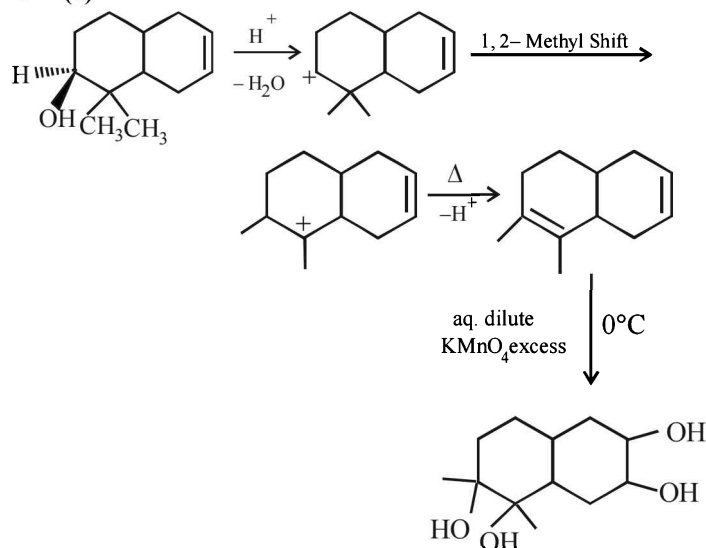

## Section-B

## JEE Main/ AIEEE

1. (d) The dehydration of alcohol to form alkene occurs in following three step. Step (1) is initiation step.

**Step (1)** Formation of protonated alcohol.

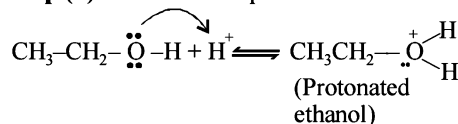

**Step (2)** Formation of carbocation

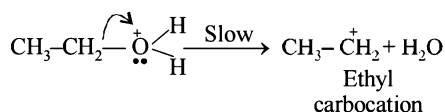

**Step (3)** Elimination of a proton to form ethene

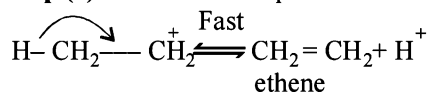

2. (a) 3-methyl pentanol-3 will be dehydrated most readily since it produces tertiary carbonium ion as intermediate.

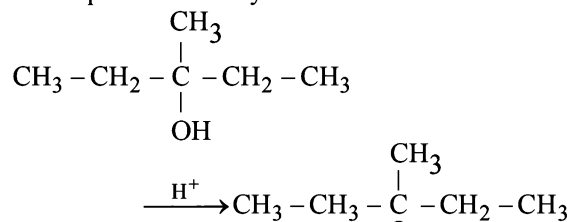

3. (a)  $\text{CH}_3\text{-CH(OH)-CH=CH-CH}_3 \longrightarrow \text{CH}_3\text{-C(OH)=CH-CH}_3$   
Pyridinium chloro-chromate (PCC) is specific for the conversion.

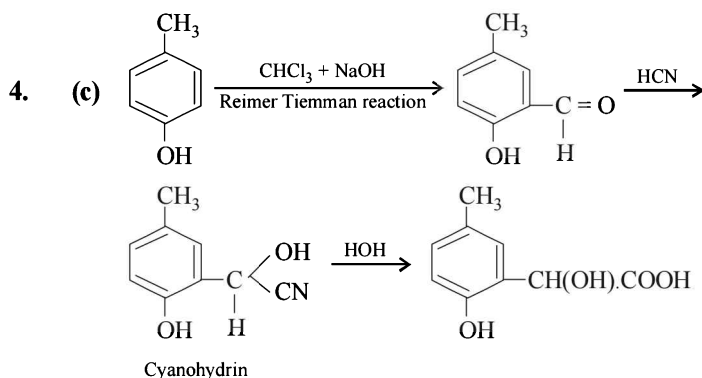

5. (b) Methyl vinyl ether under anhydrous condition at room temperature undergoes addition reaction.

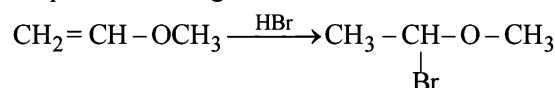

6. (b) Only those alcohols which contain  $\text{-CHOHCH}_3$  group undergo haloform reaction. Among the given options only (b) contain this group, hence undergo haloform reaction.

7. (c) **NOTE** : OH group activates the benzene nucleus and

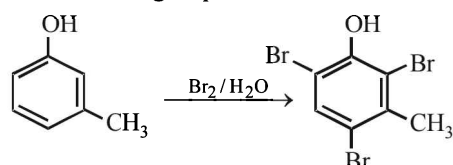

8. (d) **NOTE** : This is Reimer-Tiemann reaction and the electrophile is dichlorocarbene.

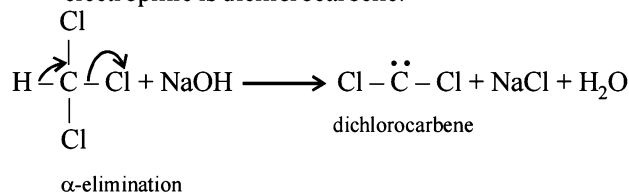

9. (d)  $\text{CH}_3\text{CH}_2\text{OH} \xrightarrow{\text{P+I}_2} \text{CH}_3\text{CH}_2\text{I}$   
A

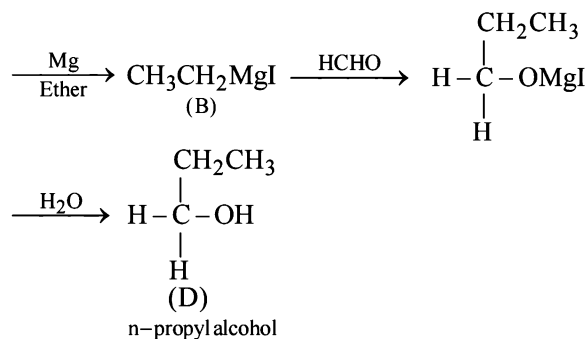

10. (b) Phenol on reaction with conc.  $\text{H}_2\text{SO}_4$  gives a mixture of *o*- and *p*- products (i.e.,  $\text{-SO}_3\text{H}$  group, occupies *o*-, *p*- position). At room temperature *o*-product is more stable, which on treatment with conc.  $\text{HNO}_3$  will yield *o*-nitrophenol.

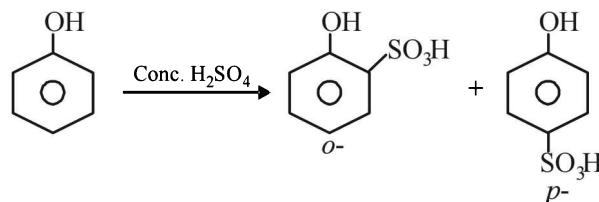

At room temperature *o*- product is more stable

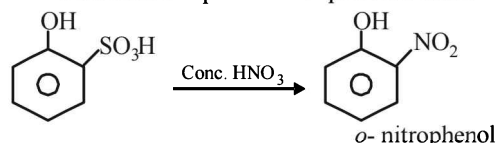

Hence (b) is the correct answer.

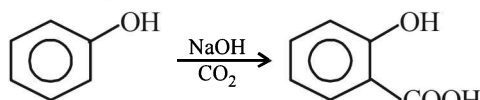
11. (b) 

12. (b) Tertiary alcohols react fastest with conc. HCl and anhydrous  $\text{ZnCl}_2$  (lucas reagent) as its mechanism proceeds through the formation of stable tertiary carbocation.

**Mechanism**

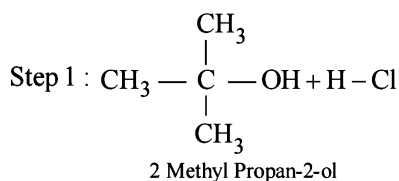







24.  $C_2H_5COCl$ ,  $C_2H_5CONH_2$ ,  $C_2H_5NH_2$       25.  $CH_3CO.O.COCH_3$ ,  $CH_3COOH$ ,  $CH_3COOC_2H_5$ ,  $C_2H_5OH$ ,  $CH_3COCH_3$   
           X                    Y                    Z                    A                    B                    C                    D                    E
26.  $CH_3CHO < CH_3COCH_3 < CH_3COCH_2CHO < CH_3COCH_2COCH_3$
27.  $SOCl_2$ ,  $POCl_3$ ,  $CH_3COCl$ ,  $CH_3COCH_3$       28.  $O_3$ ,  $KO_3$ ,  $O_2$   
           A                    B                    C                    D                    A                    B                    C
29.  $C_6H_5C \equiv CH$ ,  $C_6H_5COCH_3$ ,  $C_6H_5COOH$ ,  $CHI_3$       30. (i)  
           A                    B                    C                    D

32.  $HCOOC_3H_7$ ,  $(CH_3)_2CHOH$   
           A                    B

33.  $C_6H_5CH = CHCH = CCHO$ ,  $CHO.COOH$       41.  $\overset{*}{C}O_2$ ,  $CH_2 = CH\overset{*}{C}OOH$ ,  $CH_2 = CH\overset{*}{C}H_2OH$   
           A                    B                    X                    Y                    Z

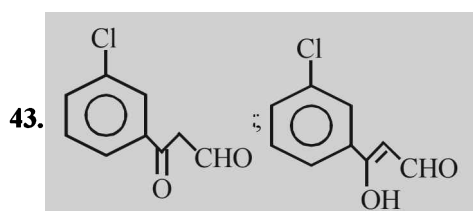
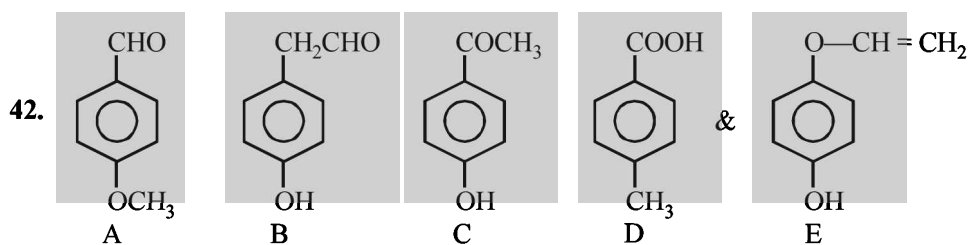

46.  $H_2C=C(CH_3).CH=CH_2$

**F** 1. (A) - r, s; (B) - p, q; (C) - p, q, r; (D) - p, s

2. (a)

**G** 1. (d) 2. (a) 3. (c) 4. (b) 5. (a) 6. (b) 7. (b) 8. (a) 9. (d) 10. (c) 11. (a)  
 12. (b) 13. (a) 14. (c) 15. (d)

**H** 1. (d) 2. (c) 3. (a) 4. (d)

**I** 1. 1 2. 4 3. 2 4. 5 5. 4

**Section-B : JEE Main/ AIEEE**

- |         |         |         |         |         |            |         |
|---------|---------|---------|---------|---------|------------|---------|
| 1. (c)  | 2. (b)  | 3. (c)  | 4. (a)  | 5. (c)  | 6. (a)     | 7. (d)  |
| 8. (b)  | 9. (c)  | 10. (c) | 11. (a) | 12. (a) | 13. (c)    | 14. (c) |
| 15. (a) | 16. (d) | 17. (a) | 18. (c) | 19. (d) | 20. (a, c) | 21. (d) |
| 22. (a) | 23. (d) | 24. (c) | 25. (b) |         |            |         |

## Section-A

## JEE Advanced/ IIT-JEE

## A. Fill in the Blanks

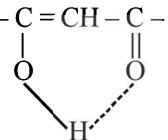
1.  $\text{CO}; \text{HCOOH} \xrightarrow[\text{heat}]{\text{Conc. H}_2\text{SO}_4} \text{CO} + \text{H}_2\text{O}$
2. sodium potassium tartarate.
3.  $\text{C}_6\text{H}_5\text{CH}(\text{OCOCH}_3)_2$  benzylidene acetate
4.  $\text{CH}_3 - \text{C} = \text{CH} - \text{C} - \text{CH}_3$   

## B. TRUE / FALSE

1. **False** : Benzaldehyde has no  $\alpha$ -hydrogen atom hence it does not undergo aldol condensation but undergoes Cannizzaro reaction.
2. **False** : Saponification is alkaline hydrolysis of esters.
3. **True** : Aldehydes (from primary alcohols) may further be oxidised easily to acids as compared to ketones (from secondary alcohols).
4. **False**. Grignard reagents react with ketones to form *ter*-alcohols; hence here *ter*-butanol will be formed.
5. **False** : H-bonding in propionic acid is stronger (carboxylic acids can form dimers) than that in butanol.

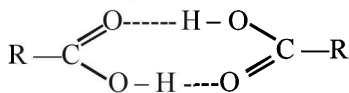

## C. MCQs with ONE Correct Answer

1. (b) Fehling solution, Schiff's reagent & Tollen's reagent react only with aldehydes but Grignard reagents react both with aldehydes and ketones.
2. (c)  $\text{CH}_3\text{CHO} + 2\text{Cu}^{2+} + \text{OH}^- \rightarrow \text{CH}_3\text{COOH} + \text{Cu}_2\text{O} \downarrow$   
 Fehling solution (red)
3. (b) **TIPS/Formulae** :  
 The compound containing  $\alpha$ -H atom does not undergo Cannizzaro's reaction.  
 Acetaldehyde does not undergo Cannizzaro reaction since it has  $\alpha$ -H atoms while formaldehyde, trimethylacetaldehyde and benzaldehyde undergo Cannizzaro reaction since they do not contain  $\alpha$ -hydrogen atoms.
4. (c) **TIPS/Formulae** :  
 Iodoform test is given by compounds having  $-\text{COCH}_3$  group.  
 In acetone  $-\text{COCH}_3$  group is present. Further ethanol and isopropyl alcohol get oxidised to acetaldehyde and acetone respectively (both having  $-\text{COCH}_3$  group) in presence of  $\text{I}_2$  and they in turn give the test. Thus only diethyl ketone does not give this test.
5. (d) **NOTE** :  $-\text{CHO}$  produces  $-\text{R}$  effect i.e. it withdraws electrons from the double bond or from a conjugated system towards itself.

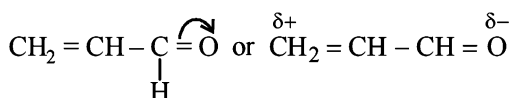

6. (a)  $\text{CH}_3 - \overset{\text{O}}{\parallel}{\text{C}} - \text{CH}_3$  (keto form)  $\rightleftharpoons$   $\text{CH}_3 - \overset{\text{:}\ddot{\text{O}}\text{H}}{\text{C}} = \text{CH}_2$  (enolic form)  
 No. of  $\sigma$  bonds in enolic form :  $3 + 1 + 1 + 1 + 1 + 2 = 9$   
 No. of  $\pi$  bonds in enolic form : 1  
 No. of lone pairs of electrons in enolic form = 2
7. (d) **NOTE** : *m*-Chlorobenzaldehyde does not contain  $\alpha$ -H atom. It is an example of Cannizzaro reaction

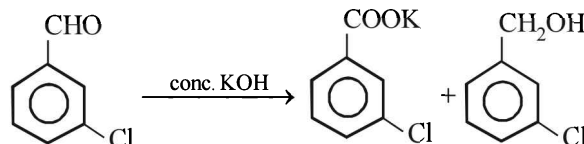

8. (b) **NOTE** : This reaction is known as Rosenmund's reaction.

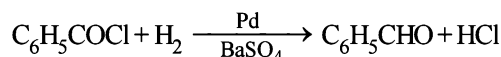

9. (a) **TIPS/FORMULAE** :  
 $\text{LiAlH}_4$  is a reducing agent, it reduces  $-\text{COOH}$  group to  $-\text{CH}_2\text{OH}$  group.



10. (a)  $\text{C}_6\text{H}_5\text{OCH}_3 \xrightarrow{\text{HI}} \text{C}_6\text{H}_5\text{OH} + \text{CH}_3\text{I}$
11. (b) The possible mechanism is

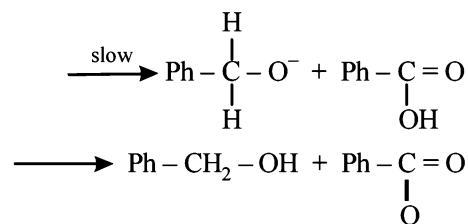
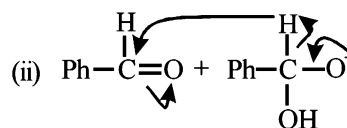
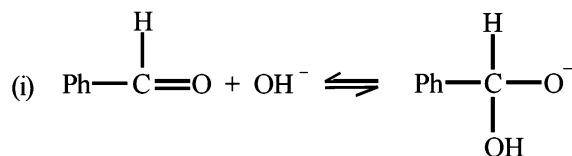

**NOTE** : The slowest step is the transfer of hydride to the carbonyl group as shown in step (ii).

12. (d)  $\text{C}_2\text{H}_5\text{COOH} + \text{NaHCO}_3 \xrightarrow{14} \text{C}_2\text{H}_5\text{COONa} + \text{H}_2\text{O} + \text{CO}_2$
13. (b) Remember that  $\alpha$ -H's of carbonyl group are easily replaced by D of  $\text{D}_2\text{O}$ .
14. (a) Compound (a) undergoes dehydration easily as the product obtained is conjugated and thus more stable.
15. (c)  $\text{C}_6\text{H}_5\text{COOH} + \text{SOCl}_2 \longrightarrow \text{C}_6\text{H}_5\text{COCl} + \text{SO}_2 + \text{HCl}$

## Aldehydes, Ketones and Carboxylic Acids

16. (b) Zn(Hg), HCl cannot be used when acid sensitive group like  $-\text{OH}$  is present, but  $\text{NH}_2\text{NH}_2$ ,  $\text{OH}^-$  can be used.

17. (a) **TIPS/Formulae :**

Both compounds do not contain  $\alpha$ -hydrogen hence undergo Crossed Cannizzaro reaction.

Initially  $\text{OH}^-$  attacks at the carbonyl carbon of HCHO than that of PhCHO because carbonyl carbon of HCHO is

- (i) more electrophilic  
(ii) less sterically hindered to give hydroxyalkoxide which acts as hydride donor in next step to give sodium formate.

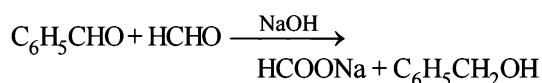

18. (c) **TIPS/Formulae :**

Ketone (non-reducing) and aldehyde (reducing) can be distinguished by Fehling solution.

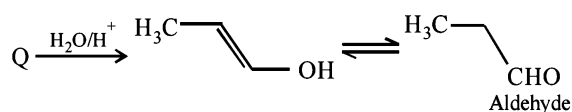
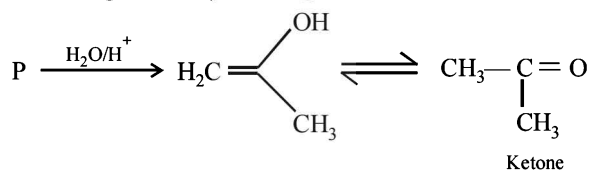

19. (b)

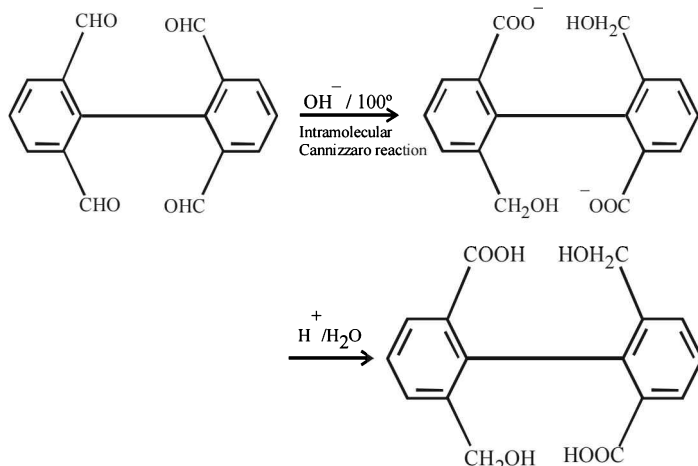

20. (a) Recall that, esters react with excess of Grignard reagents to form  $3^\circ$  alcohols having at least two identical alkyl groups corresponding to Grignard reagent.

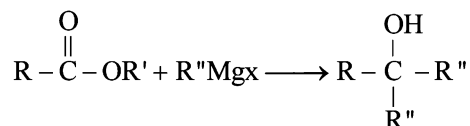

Since here Grignard reagent is  $\text{CH}_3\text{MgBr}$ , the  $3^\circ$  alcohol should have at least two methyl groups

Thus, the choice with at least two methyl groups at the carbon linked with  $-\text{OH}$  group will be the correct choice. Hence (a) is the correct choice.

21. (a) The optically active acid will react with *d* and *l* forms of alcohol present in the racemic mixture at different rates to form two diastereomers in unequal amounts leading to optical activity of the product.

22. (c) **TIPS/Formulae :**

Reaction of  $\text{PhMgBr}$  with carbonyl compounds is an example of nucleophilic addition on carbonyl group which increases with the increase in electron-deficiency of carbonyl carbon.

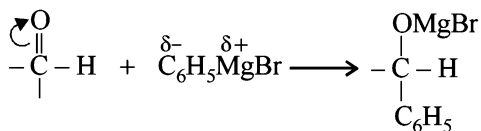

Thus acetaldehyde is most reactive while  $\text{C}_6\text{H}_5\text{COC}_6\text{H}_5$  least

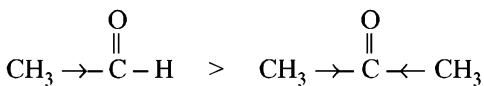

supplies least electron to group

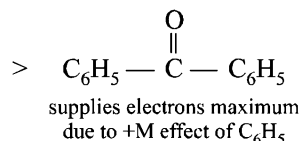

23. (c)  $\text{H}_3\text{C}-\overset{\text{O}}{\parallel}{\text{C}}-\text{CH}_2\text{CH}_3 \xrightarrow[\text{(haloform reaction)}]{\text{I}_2/\text{OH}^-}$

2-Butanone

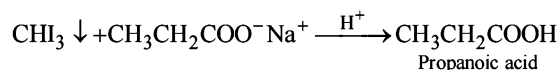

24. (c) **TIPS/Formulae :**

This reaction is an example of "Perkin reaction".

The compound X should be  $(\text{CH}_3\text{CO})_2\text{O}$ .

In this step the carbanion is obtained by removal of an  $\alpha$ -H atom from a molecule of an acid anhydride, the anion of the corresponding acid acting as a necessary base.

25. (a) This is simply an acid-base reaction.

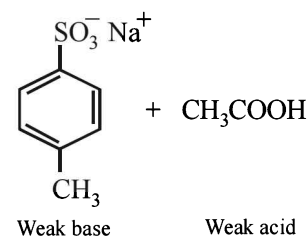
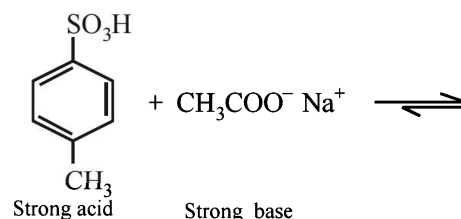

26. (c)  $\text{Ph}-\overset{\text{O}}{\parallel}{\text{C}}-\overset{\text{O}}{\parallel}{\text{C}}-\text{OH} \xrightarrow[\text{-CO}_2]{\text{Heat}} \text{Ph}-\overset{\text{O}}{\parallel}{\text{C}}-\overset{\ast}{\text{C}}\text{H}_3$

(β - keto acid)                      (E)

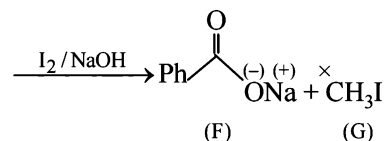

27. (a) Carboxylic acid is stronger acid than phenol. The presence of electron withdrawing group (e.g. Cl) increases acidic strength, while presence of electron donating group (e.g. CH<sub>3</sub>) decreases acidic strength.

28. (c)

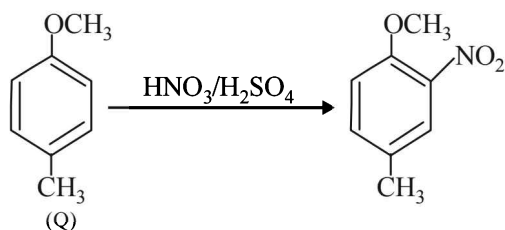
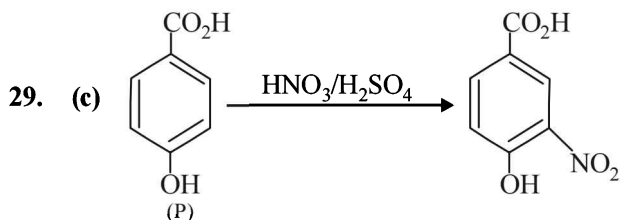
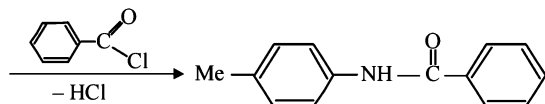
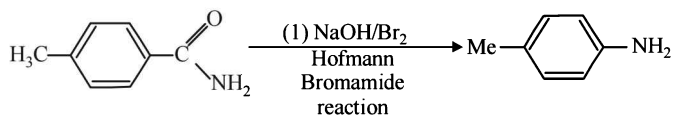

(OCH<sub>3</sub> group is more activating)

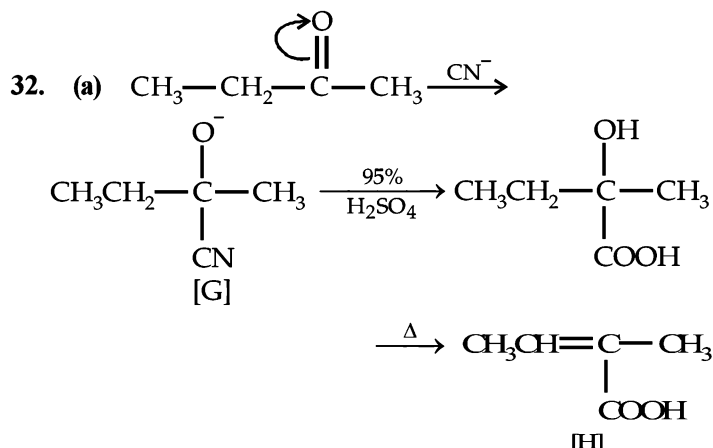
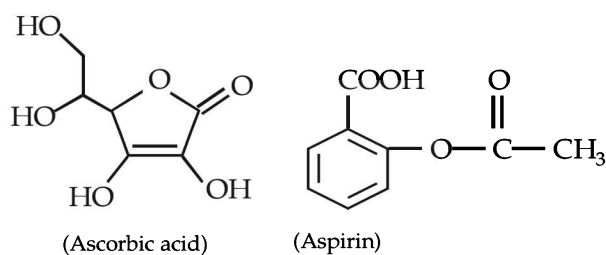
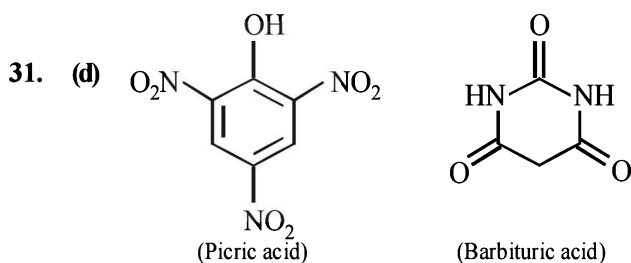
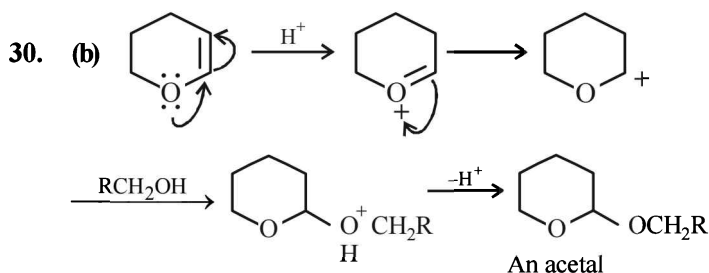
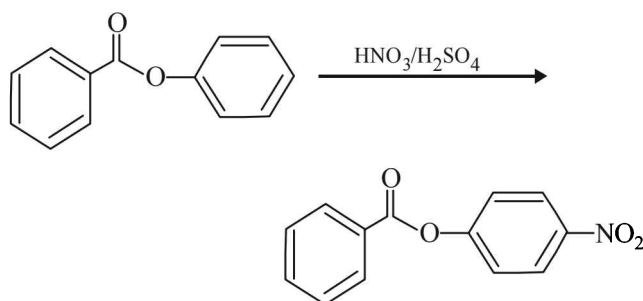

33. (b) β-Ketoacids undergo decarboxylation easily.

34. (d) Carboic acid (Phenol) is weaker acid than carbonic acid and hence does not liberate CO<sub>2</sub> on treatment with aq. NaHCO<sub>3</sub> solution.

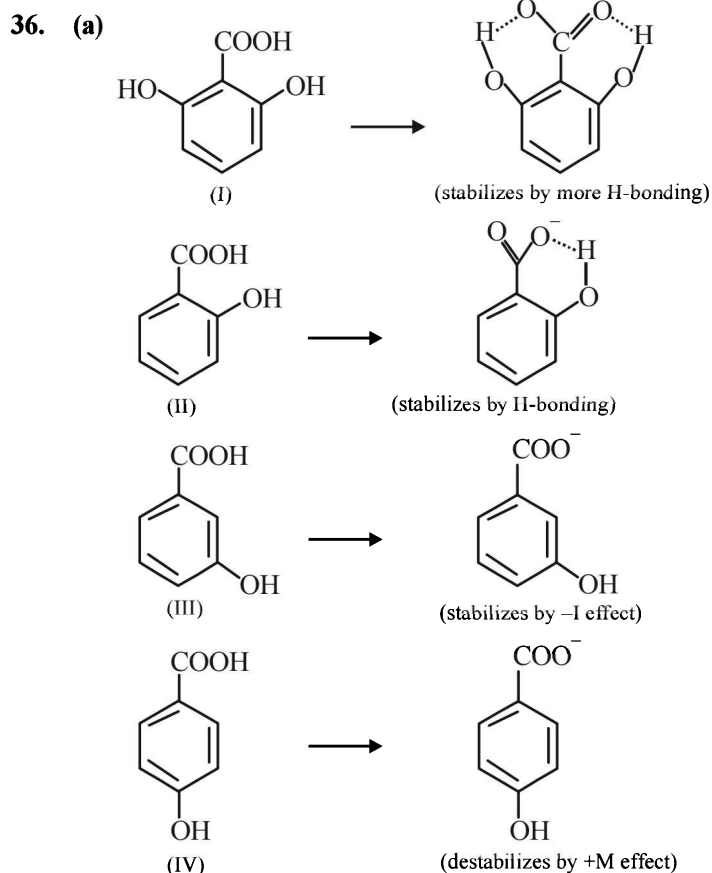
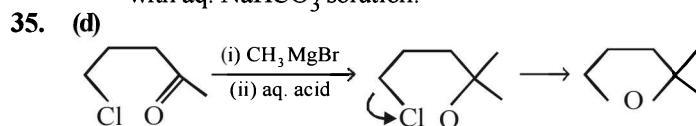

∴ acidity order is I > II > III > IV

37. (a)

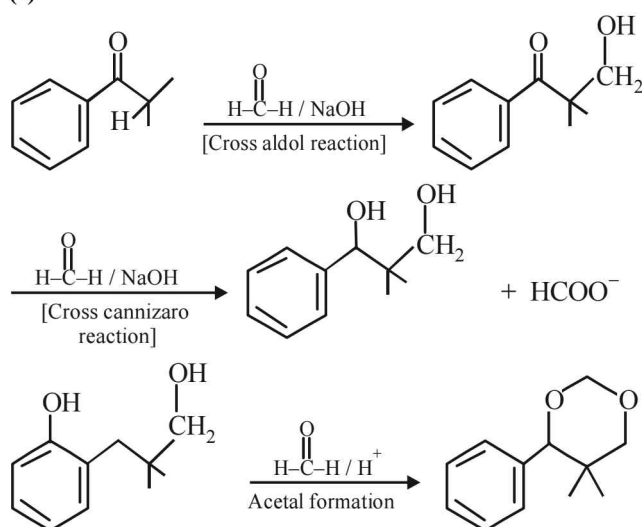
**D. MCQs with ONE or More Than One Correct**

1. (a, c) TIPS/Formulae :

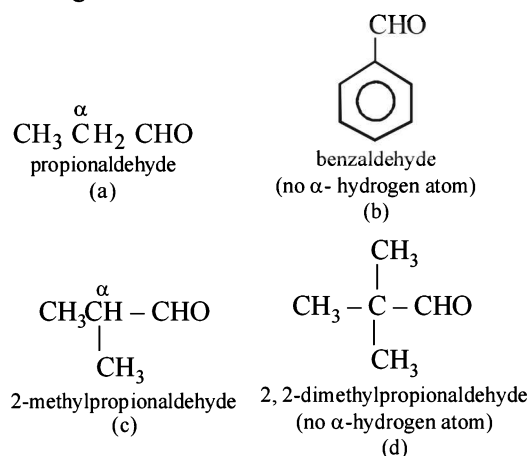
Aldehydes having at least one  $\alpha$ -hydrogen atom undergo aldol condensation.

2. (a, b) TIPS/Formulae :

Iodoform reaction is given by the compounds

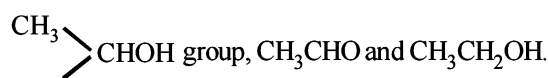
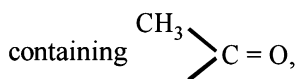

2-Hydroxypropane ( $\text{CH}_3\text{CHOHCH}_3$ ) contains the grouping  $\text{CH}_3\text{CHOH}-$  and acetophenone ( $\text{C}_6\text{H}_5\text{COCH}_3$ ) contains the grouping  $\text{CH}_3\text{CO}-$  linked to carbon and hence give yellow ppt. with  $\text{I}_2$  and alkali—**iodoform test**.

In methyl acetate ( $\text{CH}_3\text{COOC}_2\text{H}_5$ ) and acetamide ( $\text{CH}_3\text{CO}-\text{NH}_2$ ),  $\text{CH}_3\text{CO}$  is attached to a hetero atom but not to carbon atom and hence both these compounds do not give iodoform test.

3. (a,b,d) NOTE:

Ethyl chloride and acetyl chloride react with alc. KCN by nucleophilic substitution reaction while benzaldehyde undergoes benzoin condensation :

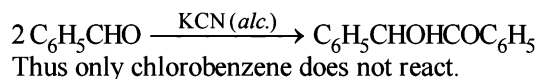
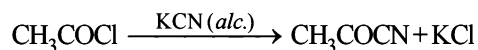
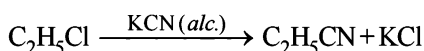
4. (b, d) Keto-enol tautomerism is shown in compounds having  $\alpha$ -hydrogen on the C adjacent to the CO group.

5. (a, b) NOTE:

Aldehydes and ketones containing  $\alpha$ -Hydrogen atom undergo aldol condensation.6. (b, d) (a)  $\text{HCHO} \xrightarrow{\text{OH}^-} \text{CH}_3\text{OH} + \text{HCOO}^-$ 

(No new C - C bond is formed)

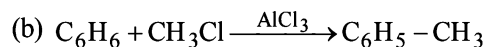

(New C - C bond is formed)

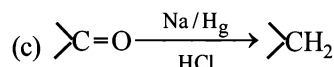

(No new C - C bond is formed)

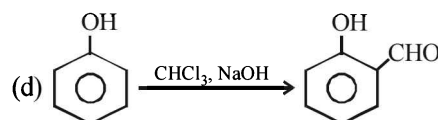

(New C - C bond is formed)

7. (b) TIPS/Formulae :

Three Cl of chloral makes its carbonyl carbon highly electron deficient, hence  $\text{H}_2\text{O}$ , a nucleophile easily adds on it forming chloral hydrate,  $\text{CCl}_3\text{CH}(\text{OH})_2$ , which is quite stable due to intramolecular H-bonding between two -OH groups.

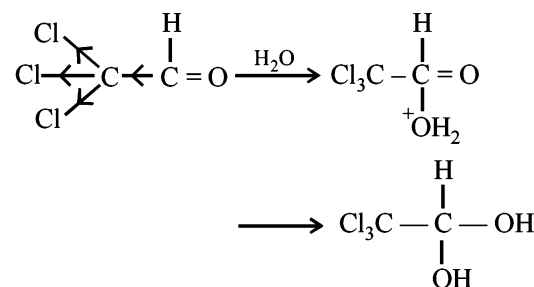

8. (a,b,d) TIPS/Formulae :

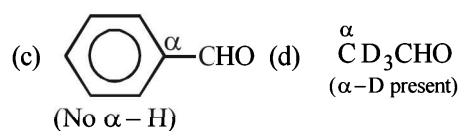
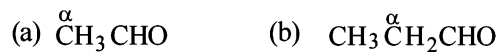
Carbonyl compounds having  $\alpha$ -H or  $\alpha$ -D undergo aldol condensation.

9. (d)

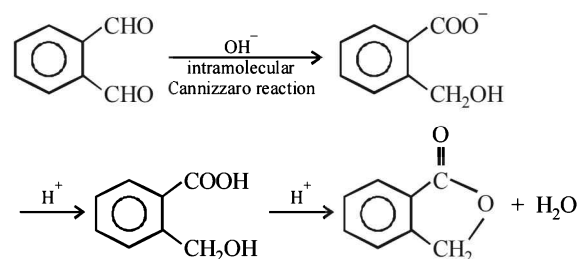

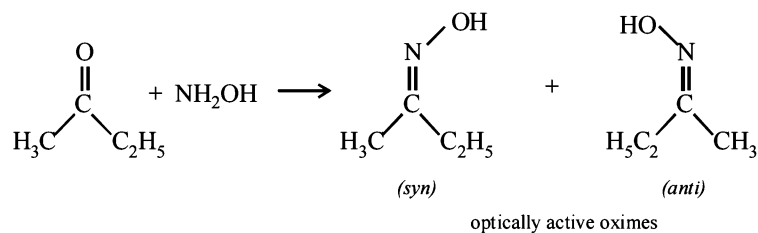
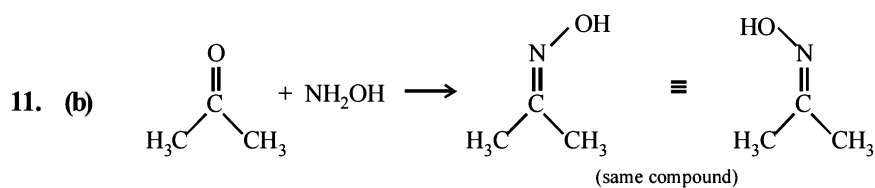
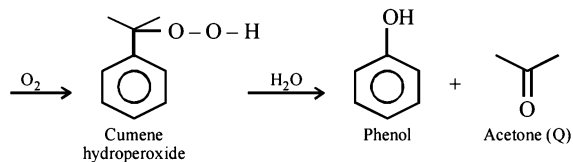
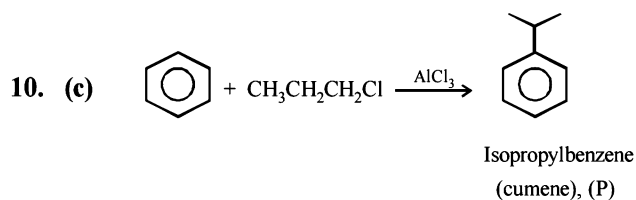

12. (b, d) (A) Both are soluble in NaOH, hence **inseparable**.  
 (B) Only benzoic acid ( $\text{C}_6\text{H}_5\text{COOH}$ ) is soluble in NaOH and  $\text{NaHCO}_3$ , while benzyl alcohol ( $\text{C}_6\text{H}_5\text{CH}_2\text{OH}$ ) is not. Hence, **separable**.  
 (C) Although NaOH can enable separation between benzyl alcohol ( $\text{C}_6\text{H}_5\text{CH}_2\text{OH}$ ) and phenol ( $\text{C}_6\text{H}_5\text{OH}$ ) as only the later is soluble in NaOH. However, in  $\text{NaHCO}_3$ , both are insoluble. Hence, **inseparable**.  
 (D)  $\alpha$ -Phenylacetic acid ( $\text{C}_6\text{H}_5\text{CH}_2\text{COOH}$ ) is soluble in NaOH and  $\text{NaHCO}_3$ . While benzyl alcohol ( $\text{C}_6\text{H}_5\text{CH}_2\text{OH}$ ) is not. Hence, **separable**.

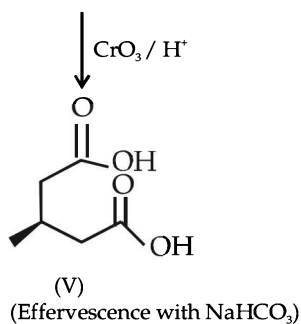
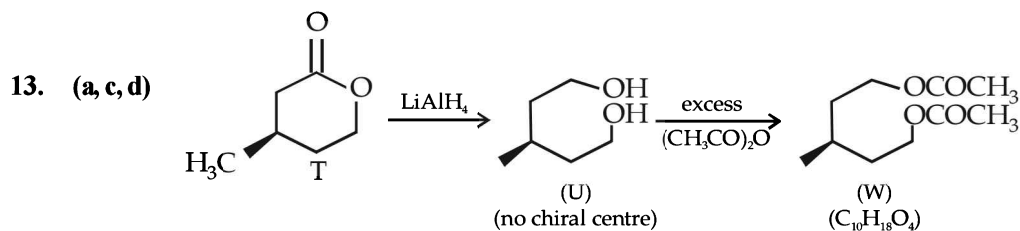

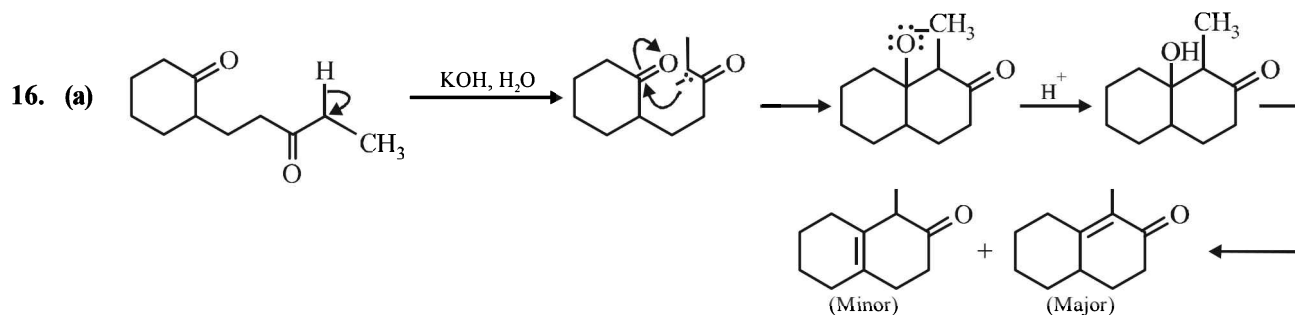
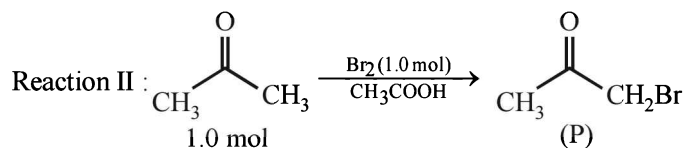
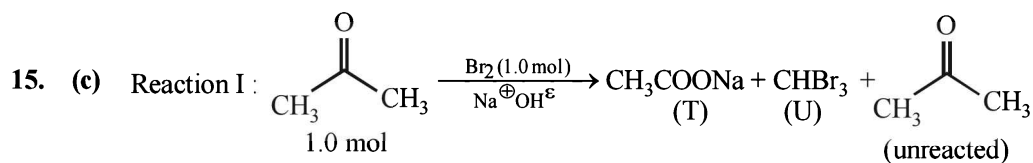
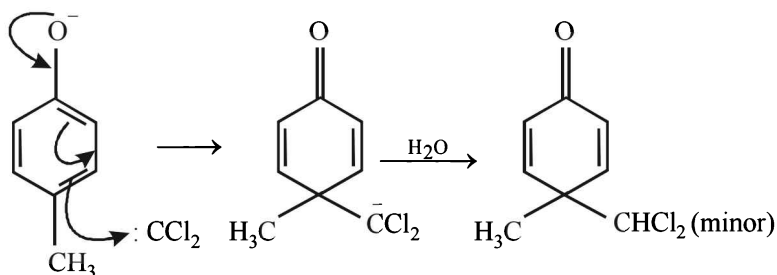
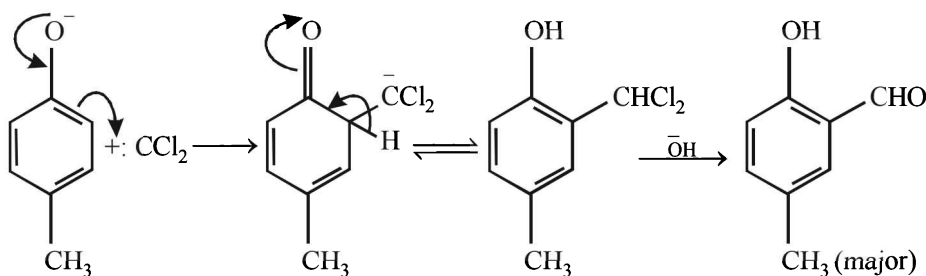
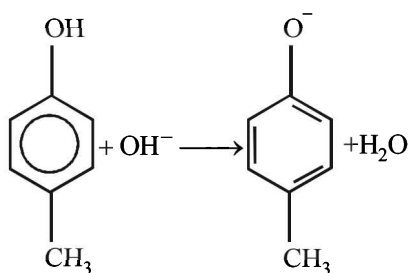
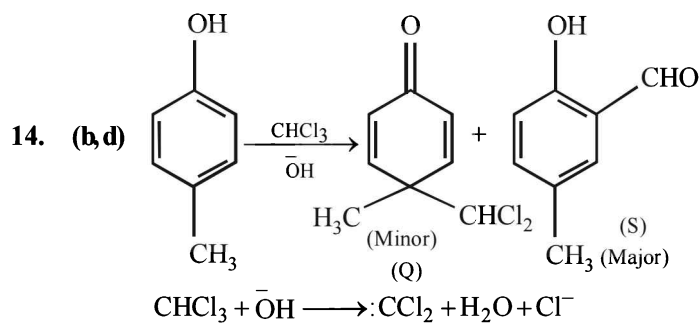

17. (a, b, c) Aldehydes and  $\alpha$ -Hydroxyketones show positive Tollen's test.

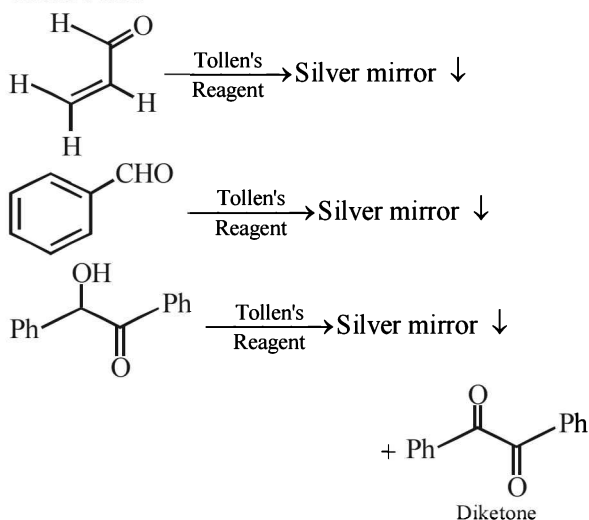

18. (b, c)

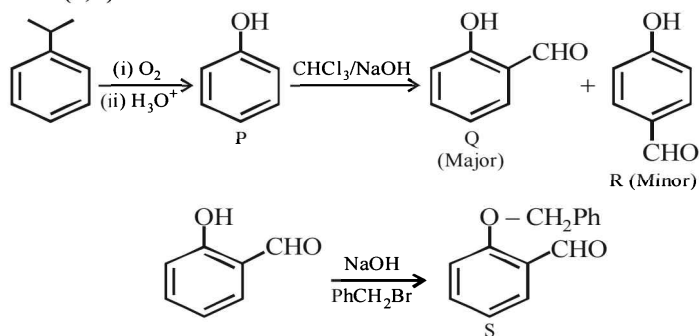

Q is steam volatile not R.

Q and R show positive test with 1% aqueous  $\text{FeCl}_3$  solution.

Q, R, S give yellow precipitate with 2, 4-dinitrophenyl hydrazine.

19. (c, d)

$\text{LiAlH}_4/(\text{C}_2\text{H}_5)_2\text{O}$  : Reduces to esters, carboxylic acid, epoxides and aldehydes and ketones.

$\text{BH}_3$  in T.H.F : Reduces to  $-\text{COOH}$  and aldehydes into alcohols but do not reduce to esters and epoxides.

$\text{NaBH}_4$  in  $\text{C}_2\text{H}_5\text{OH}$  : Reduces only aldehydes and ketones into alcohols but not to others.

Raney Ni in T.H.F. : Do not reduce to  $-\text{COOH}$ ,  $-\text{COOR}$  and epoxide but it can reduce aldehyde into alcohols.

### E. Subjective Problems

1. (i)

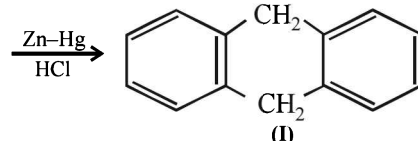
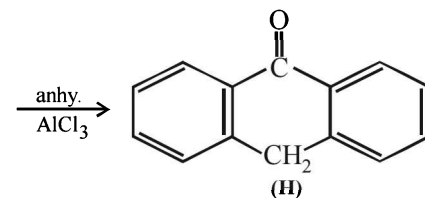
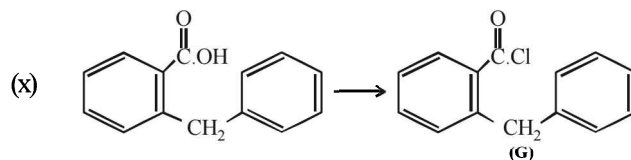
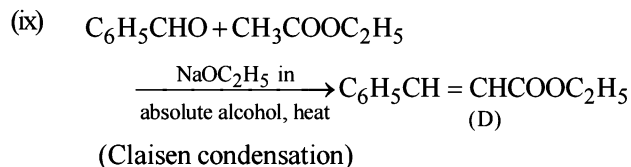
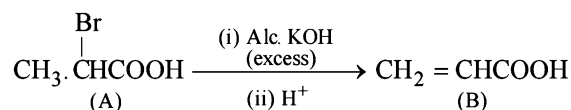
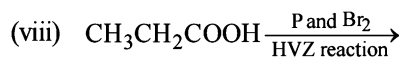
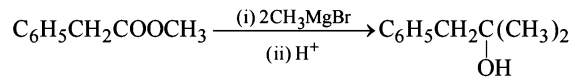
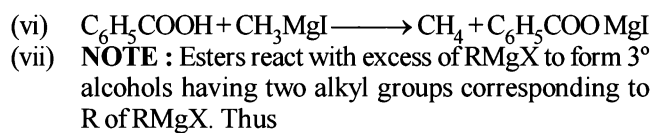
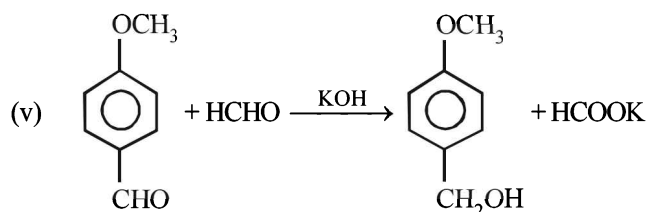
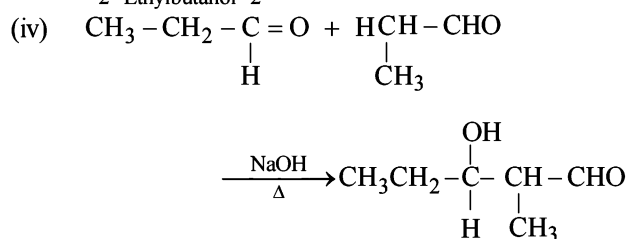
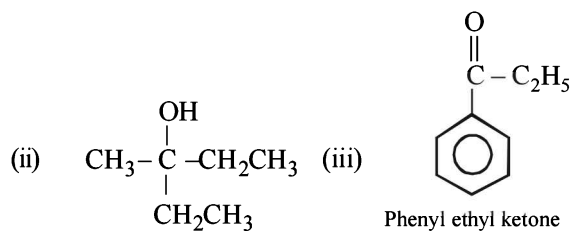
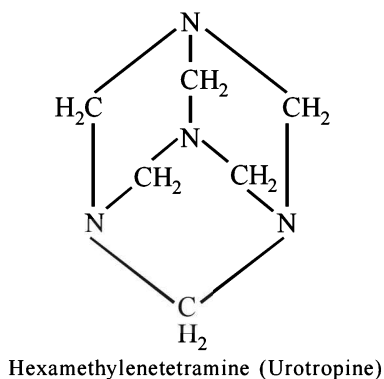



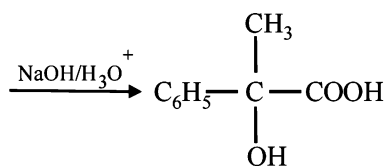
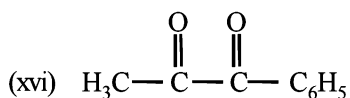
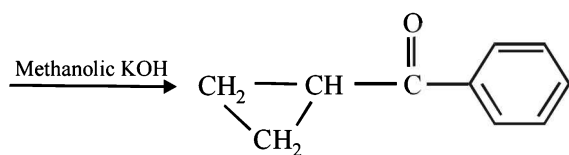
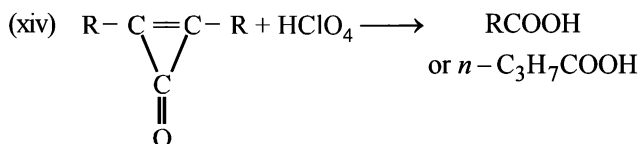
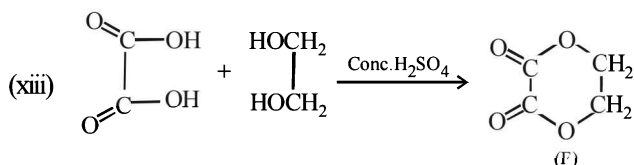
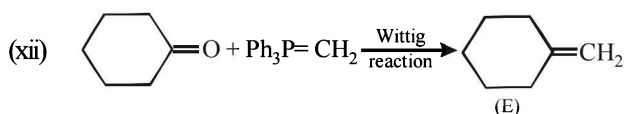
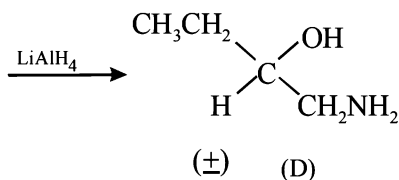
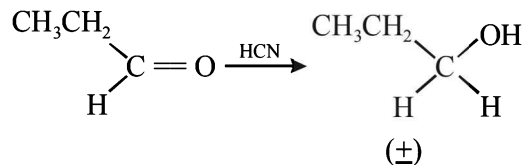
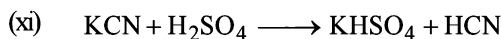

**NOTE:** The reaction is an example of benzil-benzilic acid type rearrangement.

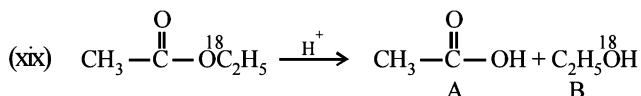
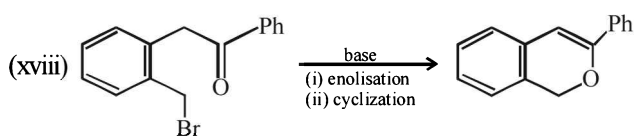
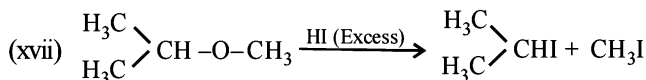

(Ester hydrolysis involves acyl-oxygen fission)

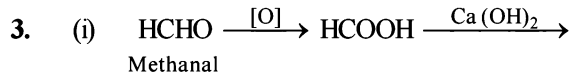
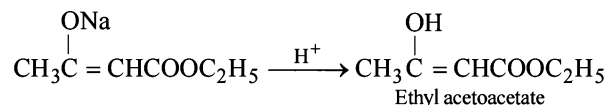
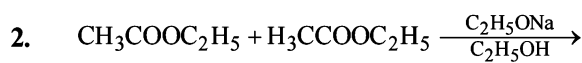
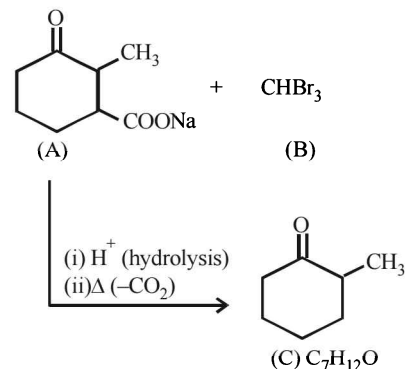
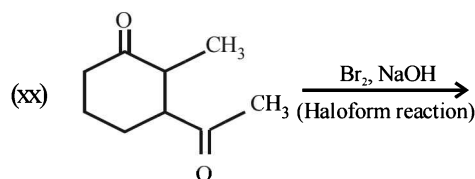

Methanal

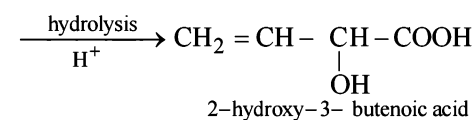
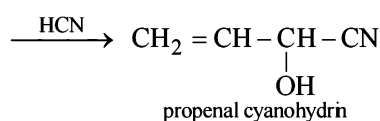
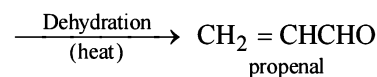
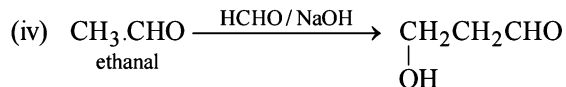
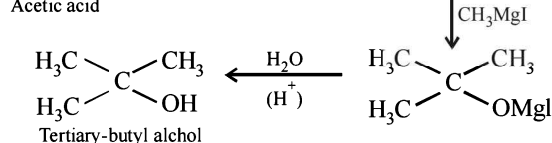
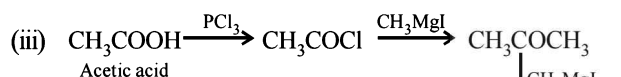
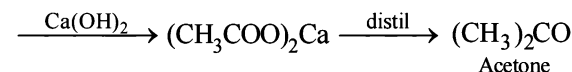
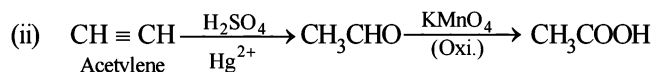
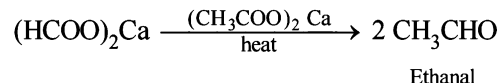

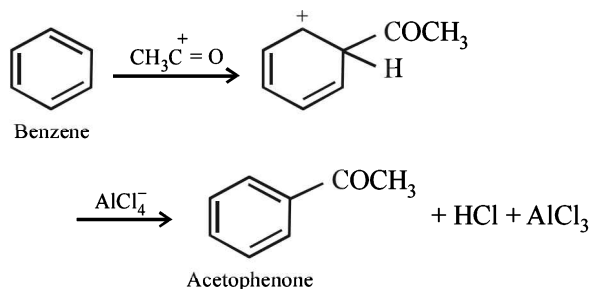
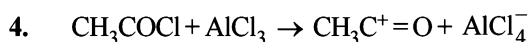
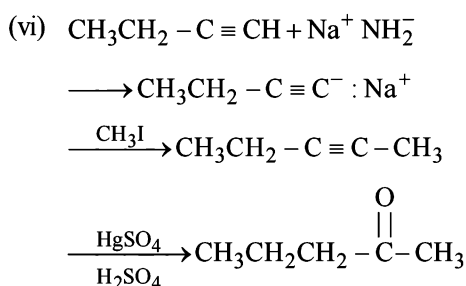
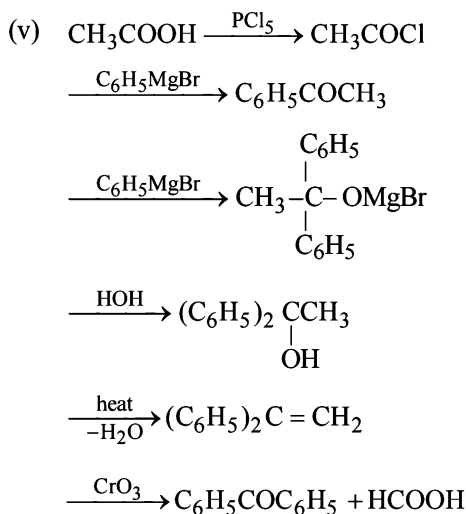

5. Ozonolysis of (A) to acetone and an aldehyde indicates the following part structure of alkene (A) :

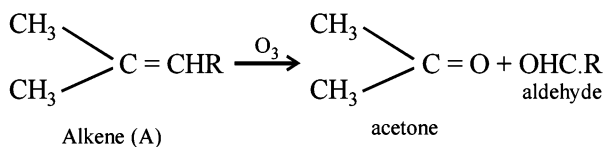

As per problem :



Bromo compound [C]  $\xrightarrow{\text{H}_2\text{O}}$  Hydroxy acid [D]  
Structure of (D) is determined by the reaction :

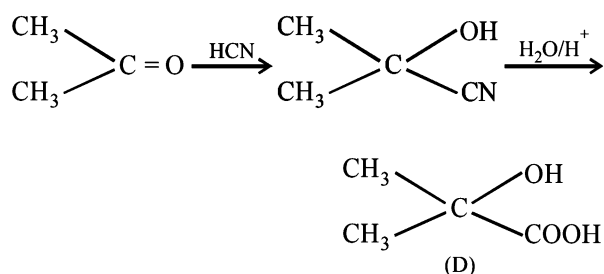

The compound (D) is obtained by hydrolysis of (C) with aqueous alkali since (C) is a bromo compound, therefore it has a bromo group where the compound (D) has a hydroxyl group. Therefore, structure of C is

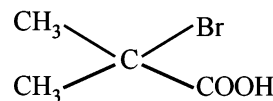

The compound (C) is formed by bromination of compound (B), therefore, the compound (B) is

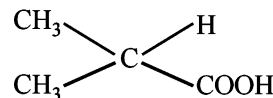

The compound (B) is formed by oxidation of an aldehyde therefore the structure of the aldehyde is

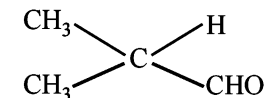

The aldehyde and acetone are formed by ozonolysis of alkene. Therefore, the double bond in alkene should be between the carbon atoms of the two carbonyl compounds (the aldehyde and acetone). Therefore, the compounds and the reactions are identified as

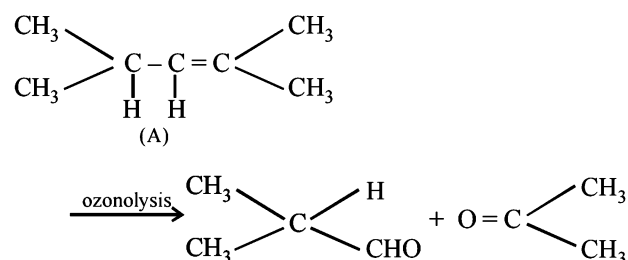

6. (i) **TIPS/Formulae :**

Formic acid has no alkyl group i.e. no  $\alpha$ -H atom, hence it does not undergo halogenation, while acetic acid has a methyl group (i.e. three  $\alpha$ -H atoms) on which halogenation takes place.

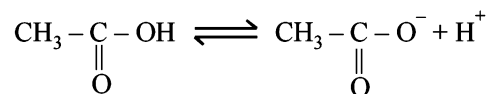
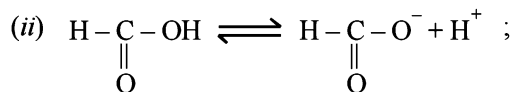

Presence of  $\text{CH}_3$  gp in acetate ion shows +I effect and thereby intensifying charge on  $\text{O}^-$  of acetate ion which is thus destabilized. Thus formate ion is more stable than acetate ion or  $\text{HCOOH}$  loses proton more easily than  $\text{CH}_3\text{COOH}$ .

- (iii) **NOTE:**

Alcohols show hydrogen bonding.

The boiling points of carbonyl compounds are lower than the corresponding alcohols since former do not show intermolecular H-bonding like alcohols.

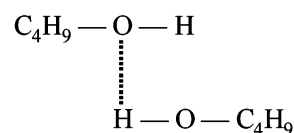



**NOTE THIS STEP:** With the help of structures of the four carbonyl compounds, (i) to (iv), we may write the structures of the two isomeric olefins (B) and (C). The two carbonyl compounds should be joined in such a way that the parent olefin has 6 carbon atoms. Two such possibilities are the combination of carbonyl compounds having 2+4 carbon atoms [*i.e.* (i) + (iv)] and 3+3 carbon atom [*i.e.* (ii) + (iii)].

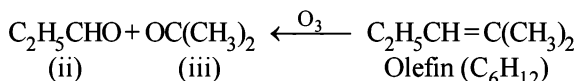
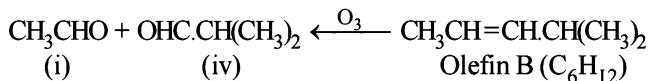

Thus the compound (A) should be a chloride that can eliminate a molecule of HCl to give B as well as C.

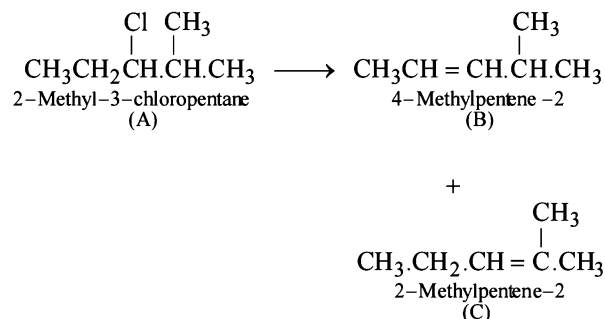

13. (X) is hydrolysed to give an acid (Y) and an alcohol (Z) and thus X is an ester;  $\text{R}-\overset{\text{O}}{\parallel}{\text{C}}-\text{OR}'$ .

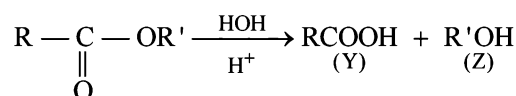

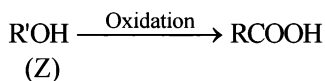

Oxidation of alcohol (Z) gives acid (Y).

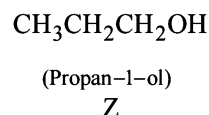
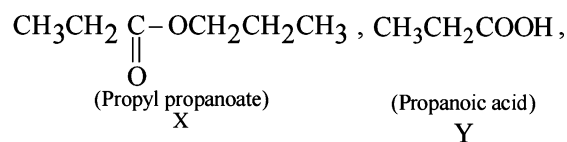

or  $\text{RCH}_2\text{OH} \longrightarrow \text{RCOOH}$  ( $\because$  R' is  $\text{R}-\text{CH}_2$ )

Hence X, Y and Z are



14. (i)  $\text{CH}_3\overset{\text{O}}{\parallel}{\text{C}}-\text{OC}_2\text{H}_5$  (iii) -CHO + CH<sub>3</sub>CHO

15. (i) Empirical formula can be calculated as

Element	Percentage	Relative no. of atoms	Simplest ratio
C	69.77	5.81	5
H	11.63	11.63	10
O	18.60	1.16	1

$\therefore$  Empirical formula of compound is C<sub>5</sub>H<sub>10</sub>O and empirical formula wt. = 86.

Also molecular wt. = 86.

$\therefore$  Molecular formula of compound is C<sub>5</sub>H<sub>10</sub>O.

- (ii) Compound forms bisulphite addition compound and thus has carbonyl gp, *i.e.* aldehyde or ketone.  
(iii) It does not reduce Fehling solution and thus it is not an aldehyde but a ketone.  
(iv) It gives positive iodoform test and thus it has

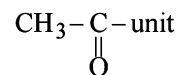

- (v) Above facts reveal that the compound is CH<sub>3</sub>CH<sub>2</sub>CH<sub>2</sub>COCH<sub>3</sub> or (CH<sub>3</sub>)<sub>2</sub>CHCOCH<sub>3</sub>  
pentan-2-one                      3-methylbutan-2-one

### 16. TIPS/Formulae :

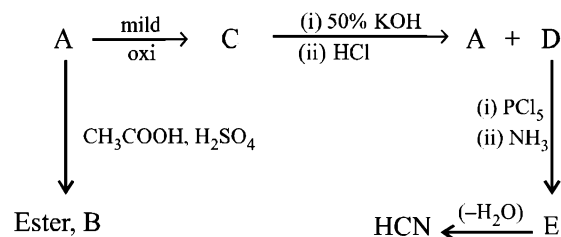

The above reactions lead to following conclusions.

- (i) Reaction of A with CH<sub>3</sub>COOH in presence of H<sub>2</sub>SO<sub>4</sub> to form ester B indicates that A is an alcohol.  
(ii) Reaction of C with 50% KOH followed by acidification to give alcohol A and the compound D seems to be the Cannizzaro reaction. Hence C must be an aldehyde and D must be an acid. The nature of C as aldehyde is again in consistent with the fact that it is obtained by the mild oxidation of A which has been established as an alcohol.  
(iii) Structure of acid D is established by its given facts.

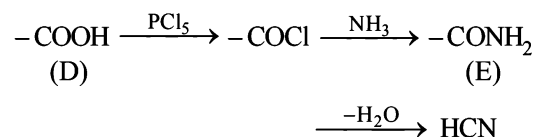

Formation of HCN by the dehydration of E establishes that E is HCONH<sub>2</sub> and hence D is HCOOH.

- (iv) Thus the alcohol A produced along with HCOOH during Cannizzaro reaction of C must be CH<sub>3</sub>OH and hence C must be HCHO.

Thus the various compounds are as below :

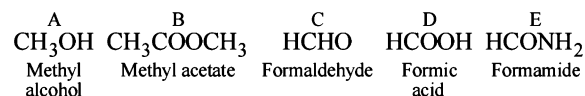

17. (i)  $\text{CH}_3-\overset{\text{OMgBr}}{\parallel}{\text{C}}-\text{CH}_3, \text{H}_2\text{O}$   
H  
(ii) P/Cl<sub>2</sub>, NH<sub>2</sub>CH<sub>2</sub>COONH<sub>4</sub>

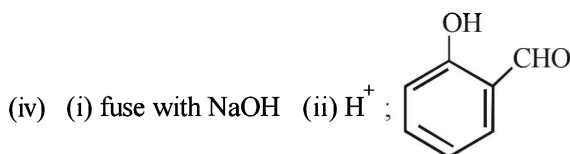
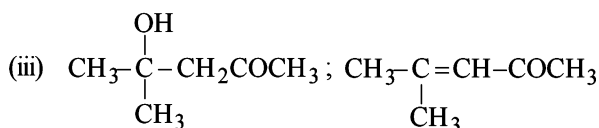
**18. TIPS/Formulae :**

For this type of problem, students are advised to summarise the whole problem in the form of reactions.

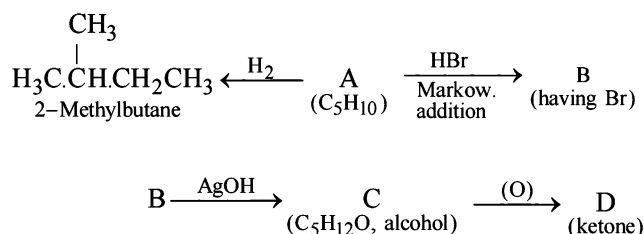

Let us draw some conclusions from the above set of reactions.

- The molecular formula  $\text{C}_5\text{H}_{10}$  ( $\text{C}_n\text{H}_{2n}$ ) for A indicates that it is an alkene having one double bond.
- Since the alcohol C on oxidation gives a ketone D, C must be a secondary alcohol and hence B must be a secondary bromide.
- The structure of 2-methylbutane, the hydrogenated product of A, indicates that the secondary bromide must have following structure.

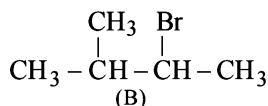

- Thus the corresponding olefin A must have structure A which on Markownikoff addition of HBr gives the bromide B, the other possible alkene A' will not give B when HBr is added on it according to Markownikoff rule.

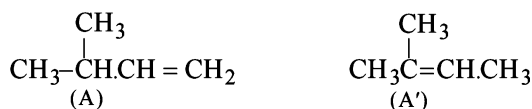

Thus the reaction involved can be represented as below:

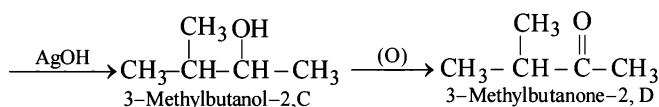
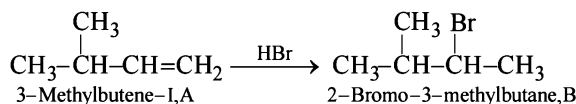

- The compound A, a ketone, undergoes haloform reaction. Thus, it must contain  $\text{CH}_3\text{CO}$  group.

The compound C gives mono-ozonide D, which shows that the compound C contains a double bond. Since the hydrolysis of D gives only acetaldehyde, the compound C would be an alkene having four carbon atoms, *i.e.*  $\text{CH}_3-\text{CH}=\text{CH}-\text{CH}_3$  (butene-2).

The compound B is obtained by the reduction of compound A (which contains  $\text{CH}_3\text{CO}$  group). Hence, the compound B would be an alcohol, which on heating with  $\text{H}_2\text{SO}_4$  gives (C). Hence B and A would be

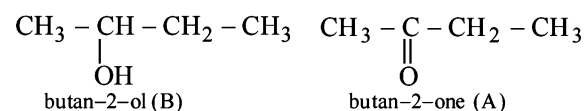

The reactions involved :

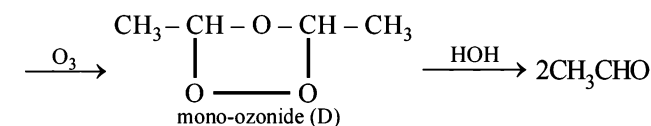
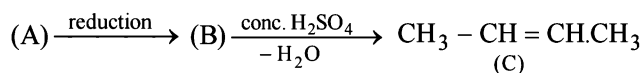
**20. TIPS/Formulae :**

The given set of reactions can be represented as below :

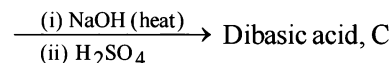
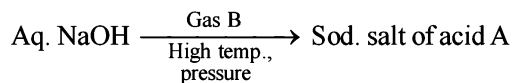

Calculation of molecular formula of C

$$\% \text{ of H} = \frac{2}{18} \times \frac{0.08}{0.40} \times 100 = 2.22\%$$

$$\% \text{ of C} = \frac{12}{44} \times \frac{0.39}{0.40} \times 100 = 27.30\%$$

$$\% \text{ of O} = 100 - (2.22 + 27.30) = 71.48\%$$

By usual method, empirical formula of acid C =  $\text{CHO}_2$

$$\text{Eq. wt. of acid C} = \left( \frac{1.0}{0.71} \times 108 \right) - 107 = 45$$

$$\text{Mol. wt. of acid C} = 45 \times 2 = 90$$

$$\therefore \text{Mol. formula of C} = \text{C}_2\text{H}_2\text{O}_4$$

Since it is dicarboxylic acid, it must have two  $-\text{COOH}$  groups.

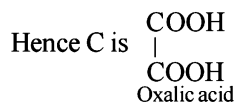

Going back, compound C must be produced from sodium oxalate which in turn is produced from sodium formate. Hence A is formic acid and B is  $\text{CO}_2$ . Thus the complete series of reactions can be written as below.

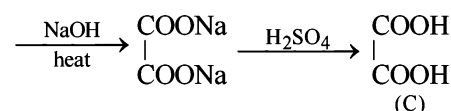
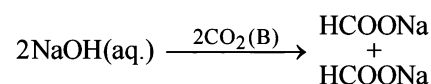

## 21. TIPS/FORMULAE:

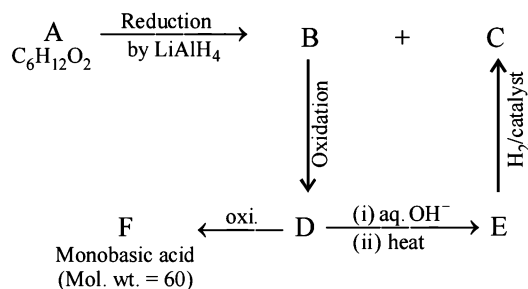

Molecular weight of the monobasic acid (RCOOH) indicates that the R- should be  $\text{CH}_3$ - i.e., acid F should be acetic acid ( $\text{CH}_3\text{COOH}$ , mol. wt.  $15+45$ ). Thus compound D must be acetaldehyde  $\text{CH}_3\text{CHO}$ , and compound B which on oxidation gives  $\text{CH}_3\text{CHO}$  must be ethanol,  $\text{CH}_3\text{CH}_2\text{OH}$ .

Acetaldehyde (D) on treating with aqueous alkali will undergo aldol condensation.

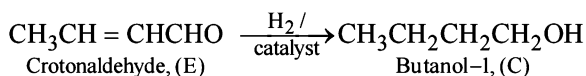
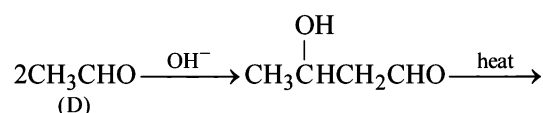

*Nature of A.* Thus it is evident that reduction of A with  $\text{LiAlH}_4$  gives two alcohols; B (ethanol) and C (butanol). Hence A must be an ester i.e., ethyl butanoate ( $\text{CH}_3\text{CH}_2\text{CH}_2\text{COOC}_2\text{H}_5$ ).

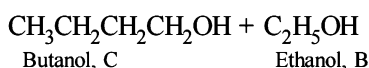
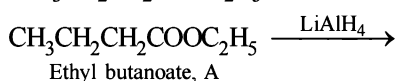

## 22. Empirical formula of A and B.

	Relative No. of atoms	Simplest ratio
% of C = $\frac{12}{44} \times \frac{0.308}{0.108} \times 100 = 77.77$	$\frac{77.77}{12} = 6.48$	$\frac{6.48}{0.92} = 7$
% of H = $\frac{2}{18} \times \frac{0.072}{0.108} \times 100 = 7.40$	$\frac{7.40}{1} = 7.40$	$\frac{7.40}{0.92} = 8$
$\therefore$ % of O = $100 - (77.77 + 7.40) = 14.83$	$\frac{14.83}{16} = 0.92$	$\frac{0.92}{0.92} = 1$

$\therefore$  Empirical formula of A and B =  $\text{C}_7\text{H}_8\text{O}$

*Nature of (A):* Since A is insoluble in  $\text{NaOH}$  and  $\text{NaHCO}_3$ , it can't have  $-\text{OH}$  and  $-\text{COOH}$  groups. Further the reaction of A with conc.  $\text{HI}$  to give compounds C and D separable by means of ammonical  $\text{AgNO}_3$  and solubility of D in  $\text{NaOH}$  indicates that C and D are alkyl halide and phenol respectively. Thus A is an ether i.e. it is  $\text{C}_6\text{H}_5\text{OCH}_3$  which explains all the given reactions.

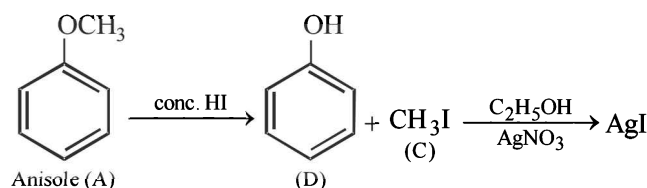

*Nature of (B):* Solubility of B ( $\text{C}_7\text{H}_8\text{O}$ ) in  $\text{NaOH}$  indicates that it is a phenol which is further confirmed by its reaction with bromine water to give compound E of molecular formula,  $\text{C}_7\text{H}_5\text{OBr}_3$ . Further bromination of B to give tribromo product indicates that it is *m*-cresol.

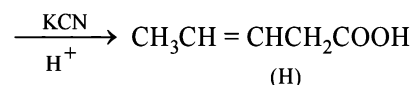
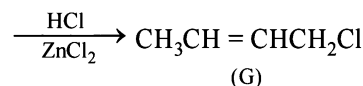
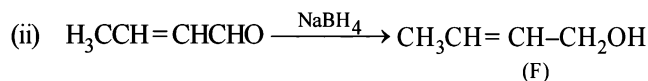
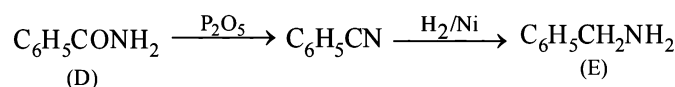
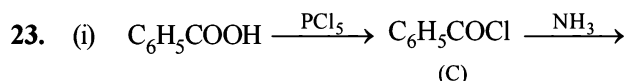
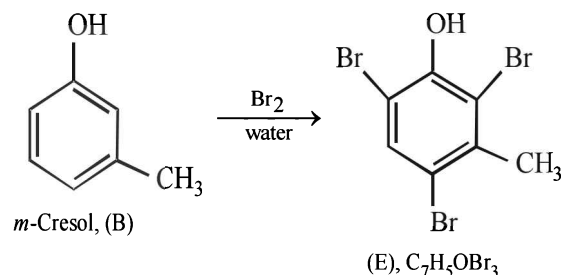

## 24. For empirical formula of (Y)

Element	%	Relative no. of atoms	Simplest ratio
C	49.31	4.10	3
H	9.59	9.59	7
N	19.18	1.37	1
O	21.92	1.37	1

$\therefore$  Empirical formula of (Y) is  $\text{C}_3\text{H}_7\text{NO}$ .

(Y) reacts with  $\text{Br}_2$  and  $\text{NaOH}$  to give (Z) and (Z) reacts with  $\text{HNO}_2$  to give ethanol and thus (Y) seems to have  $-\text{CONH}_2$  group.

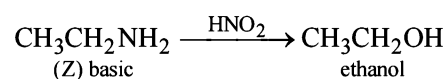
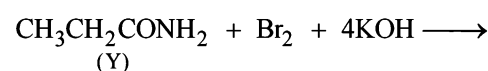

Y is formed from (X) having Cl on treatment with  $\text{NH}_3$  and so (X) is  $\text{CH}_3\text{CH}_2\text{COCl}$  i.e. propanoyl chloride.

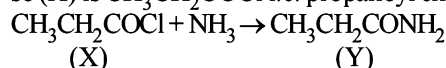

## 25. TIPS/Formulæ:

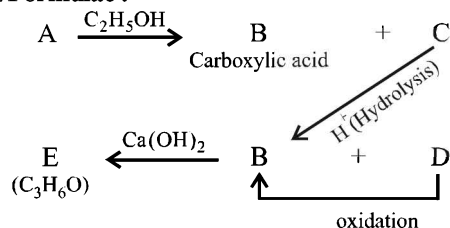



33. Following informations are provided by the problem.

- Since aldehyde A ( $C_{11}H_8O$ ) gives  $C_6H_5CHO$  on ozonolysis, it must have a benzene nucleus and a side chain. The side chain should have five carbon ( $C_{11}-C_6=C_5$ ), three hydrogen ( $H_8-H_5=H_3$ ) and one oxygen atom, i.e., it should be  $C_5H_3O$ . Further the compound A has an aldehydic group, so the side chain can be written as  $C_4H_2CHO$ .
- Formation of two moles of B from one mole of A by ozonolysis indicates that the side chain must possess two unsaturated linkages, one of which must be alkyne type, suggested by very low number of hydrogen atoms.
- Further since the aldehyde A does not undergo aldol condensation,  $\alpha$ -hydrogen is absent and hence triple bond should be present between  $C_2$  and  $C_3$ .
- Thus the side chain  $C_4H_2CHO$  of A can be written as  $CH=CH-C\equiv C-CHO$ .
- Thus compound A should possess following structure which explains all the given reactions.

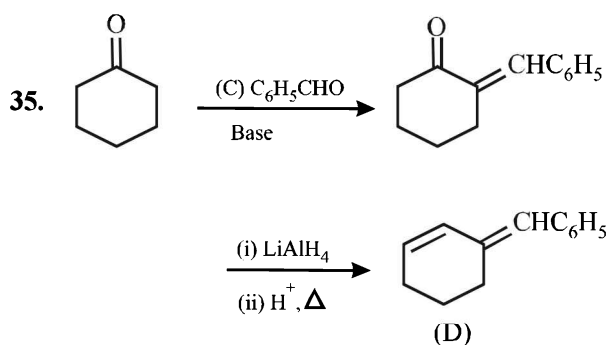
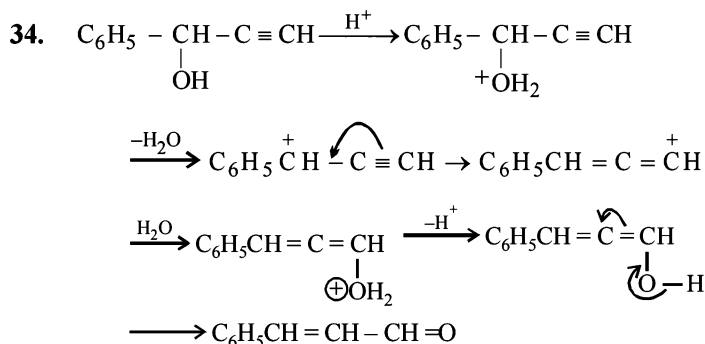
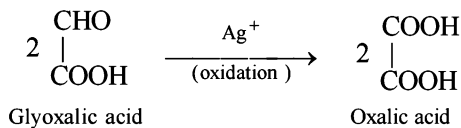
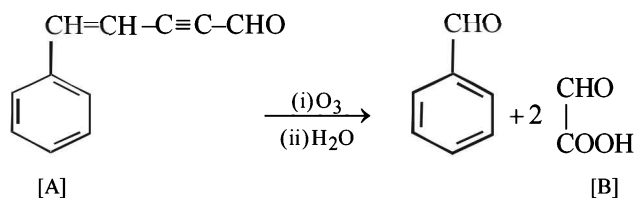

$\text{LiAlH}_4$  reduces only ketonic group to  $2^\circ$  alcoholic group without affecting double bond.

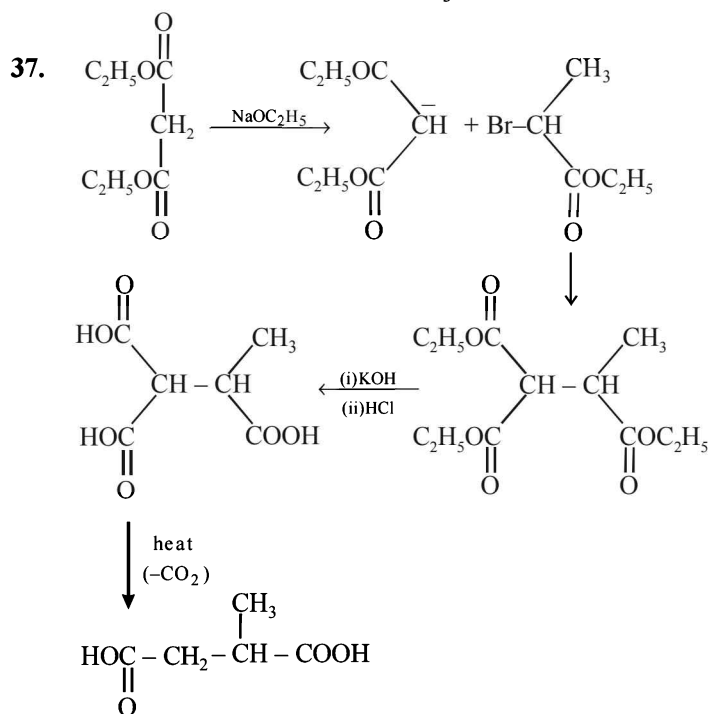
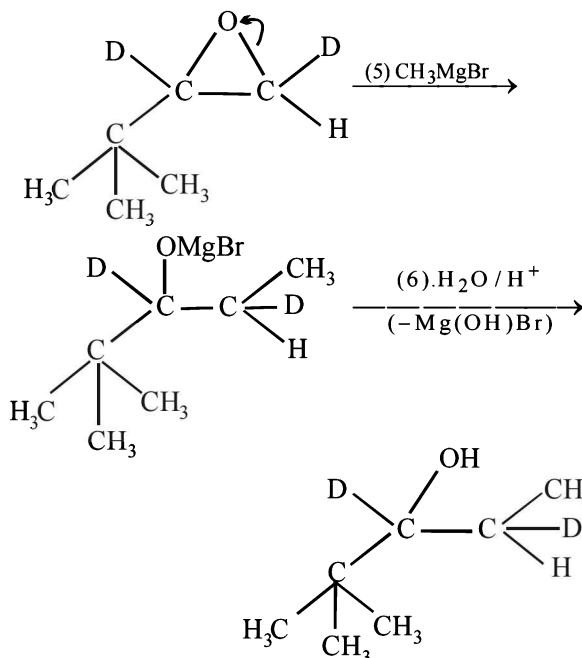
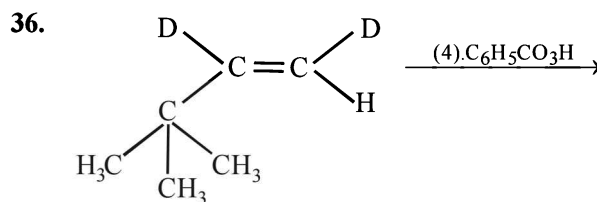

38. TIPS/Formulae :

The given reaction can be summarised as below :

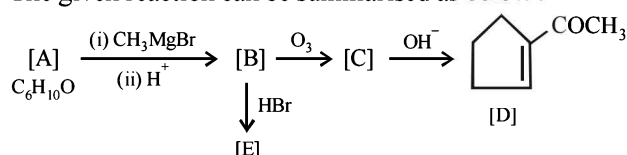

Conclusions from the set of reactions

- Carbon-hydrogen ratio of A indicates that it is a cyclic compound



## Aldehydes, Ketones and Carboxylic Acids

- (ii) Reaction of A with  $\text{CH}_3\text{MgBr}$  indicates that it should have a ketonic group.
- (iii) As B undergoes ozonolysis to form C, It must have a double bond, and C must have two carbonyl groups.
- (iv) Reaction of C (a dicarbonyl compound) with a base gives a cyclic compound, it indicates that intramolecular condensation have occurred during this conversion. Thus A is cyclohexanone which explains all the given reactions.

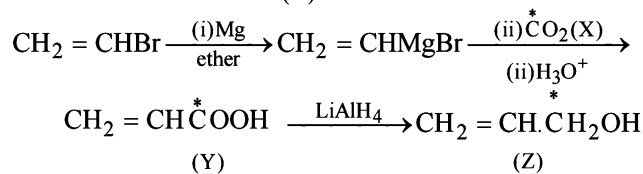
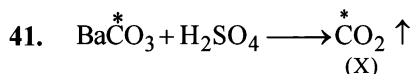
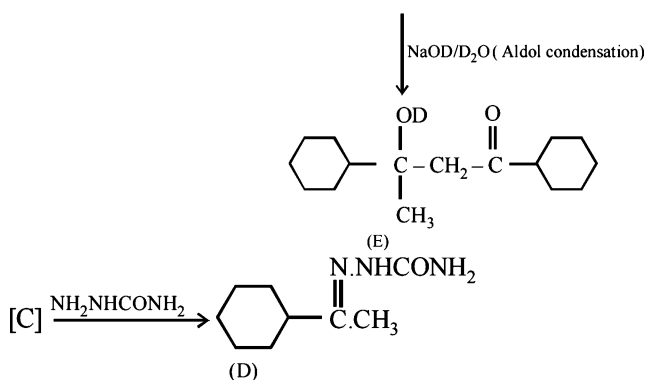
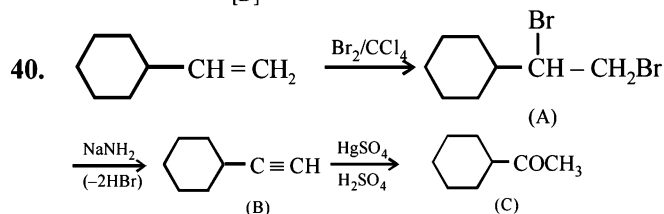
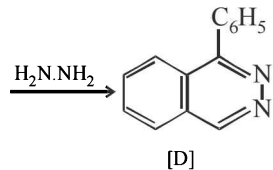
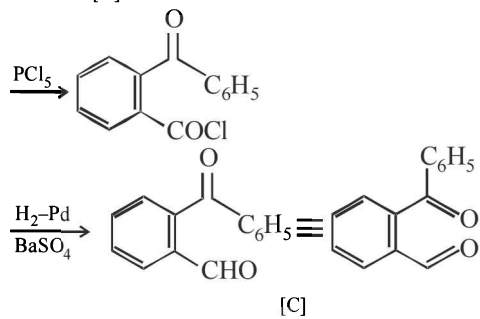
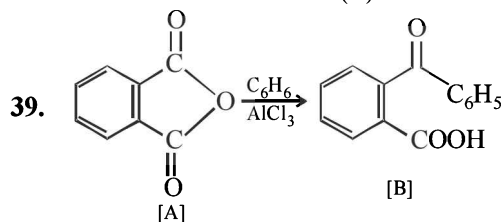
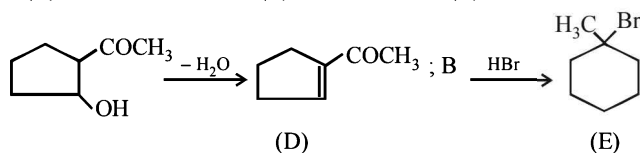
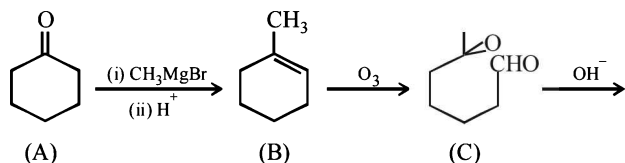

Formation of  $\text{CH}_2\text{O}$  from (Z)

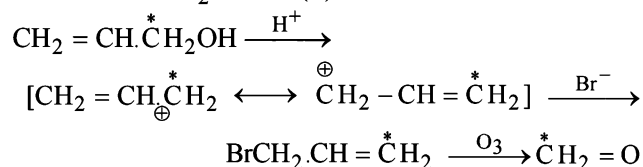

42. (i) As both the compounds A and B form a silver mirror with Tollen's reagent, they have aldehydic group in their structure. In these compounds, B gives positive test with  $\text{FeCl}_3$  solution, so it must also have phenolic group in its structure. Hence, compound A is *p*-methoxybenzaldehyde and B is *p*-hydroxyphenylacetaldehyde.
- (ii) Compound C gives positive iodoform test, so it must have  $\text{CH}_3\text{CO}$ -group in its structure. Hence compound C is *p*-hydroxyphenylmethyl ketone.
- (iii) Compound D is readily extracted in aqueous  $\text{NaHCO}_3$ , so it must have  $-\text{COOH}$  group in its structure. So, compound D is *p*-methylbenzoic acid.
- (iv) Compound E on hydrolysis gives 1,4-dihydroxybenzene. So, compound E is *p*-hydroxyphenyl vinyl ether. Hence the structures of all the five compounds are :

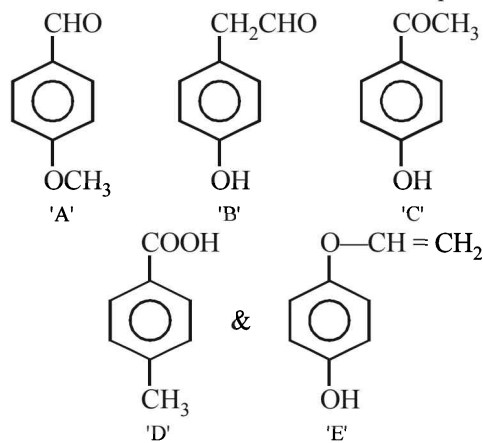

## 43. TIPS/Formulae :

Meso forms are optically inactive.

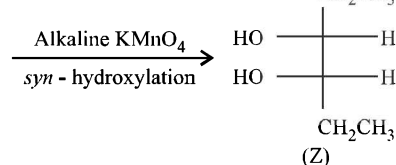
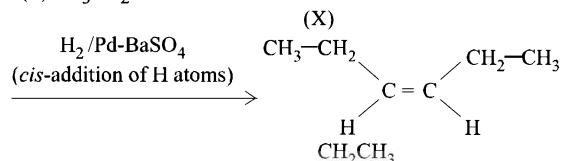
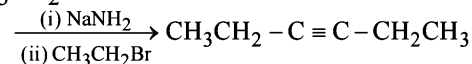
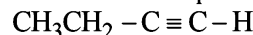

Z is in meso form having plane of symmetry. The upper half molecule is mirror image of the lower half molecule. The molecule is, therefore, optically inactive due to internal compensation.

44. The two enantiomers of 2-phenylpropanoic acid in the racemic mixture react with (+) - alcohol to form two diastereomers.

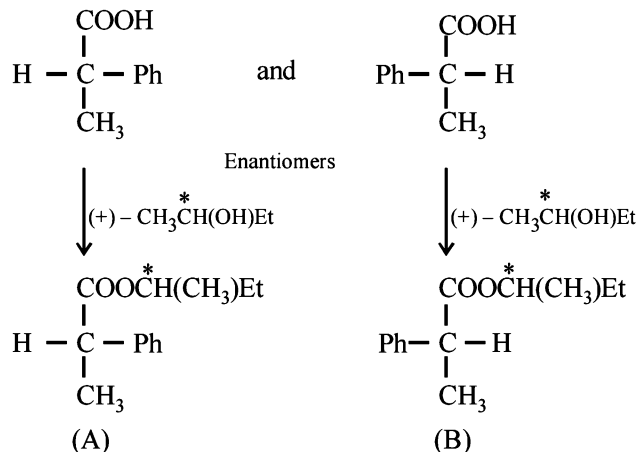

(A) and (B) are diastereomers.

The bonds attached to the chiral carbon in both the molecules are not broken during the esterification reaction. (+) - Acid reacts with (+) - alcohol to give an (+) - (+) - ester, while (-) acid reacts with (+) alcohol to give (-) - (+) - ester. These two esters are diastereoisomers.

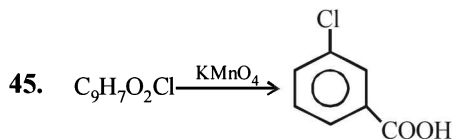

Hence compound should have following part structure

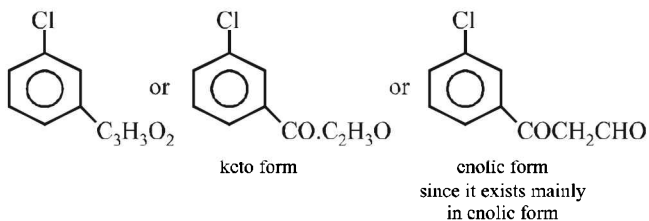

The enolic form of the compound is more stable than the keto form due to hydrogen bonding.

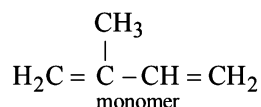
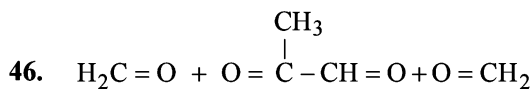
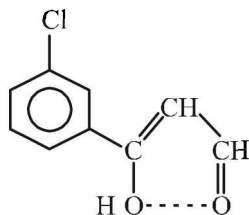

Thus the possible polymer should be

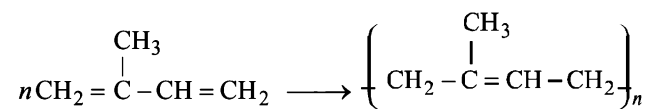

Structure of all *cis* configuration of the polymer.

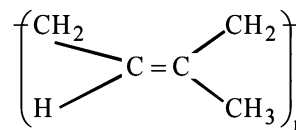

All *cis* form

### F. Match the Following

1. (A) - r, s; (B) - p, q; (C) - p, q, r; (D) - p, s  
compound (A) does not have carbon, hence does not responds (p) test.

2. (a)

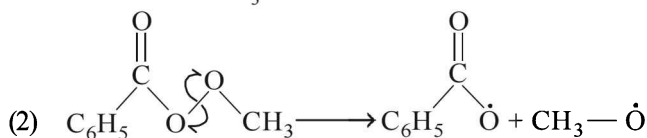
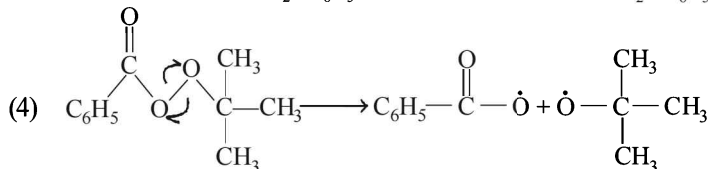
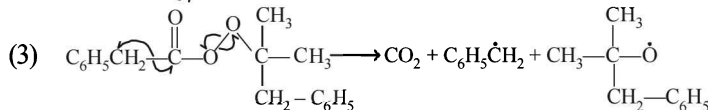
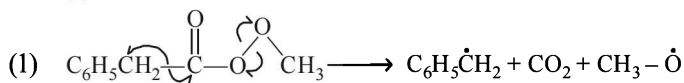

### G. Comprehension Based Questions

1. (d)  $\text{CH}_3 - \text{CH}_2 - \text{C} \equiv \text{C} - \text{CH}_2 - \text{CHO}$   
Hex-3-yнал

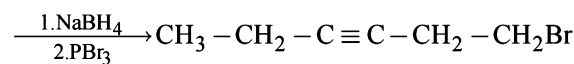

Product 'I'

Sodium borohydride reduces -CHO  
Selectively into -CH<sub>2</sub>OH

2. (a)  $\text{Me} - \text{CH} = \text{CH} - \text{CH}_2\text{Br}$

"I"

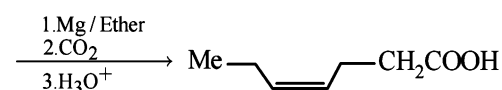

"J"

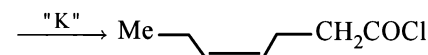

Thus "K" is  $\text{SOCl}_2$

## Aldehydes, Ketones and Carboxylic Acids

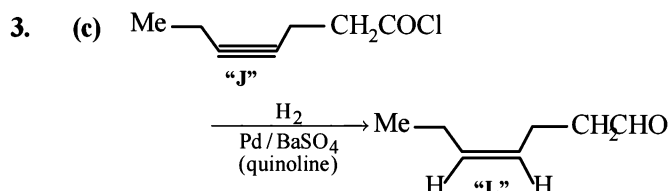

It is Rosemund reaction. Simultaneously the reagent  $H_2$ -Pd also reduces carbon-carbon triple bond to double bond (*syn*-addition) giving *cis* product.

## For 4-6.

Iodoform test of compound **P** points out that **P** has  $-COCH_3$  group which shows that it may be either option (a) or (b) of Q. 16. Further since the dicarbonyl compound **R** has at least one  $\alpha$ -H atom w.r.t to one of the carbonyl groups which is possible when **R** is produced from (b) of Q. 18; (a) option of Q. 16 will give dicarbonyl compound having two  $-CHO$ , none of which has  $\alpha$ -H atom.

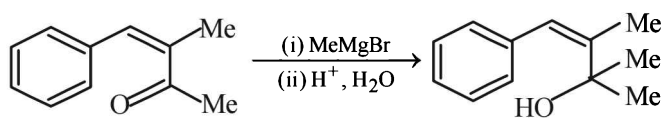

(B)/P

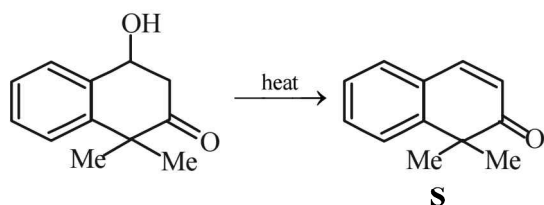
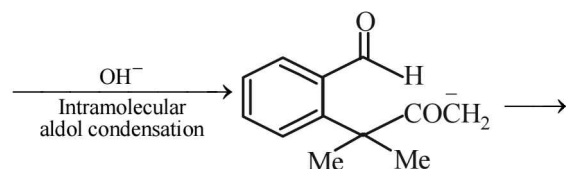
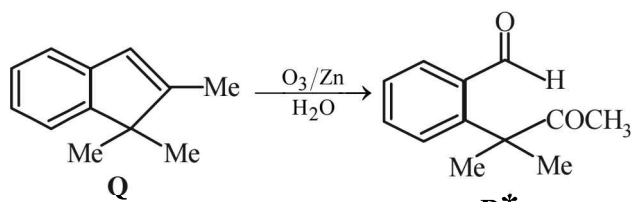
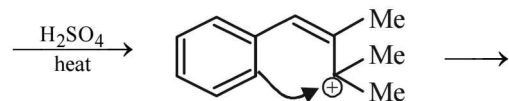

\* Structure of **R** would be **R'** when **P** is (A)

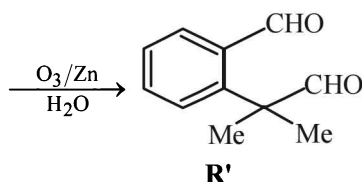
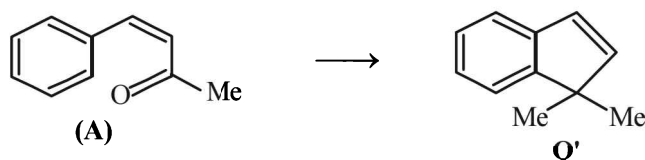

4. (b) 5. (a) 6. (b)

For 7-9. Let us summarize the given facts of the problem.

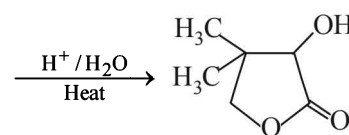
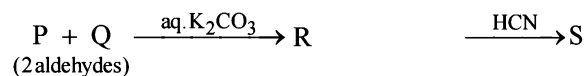

Structures of **P**, **Q**, **R** and **S** can be established on going backward from the known final product.

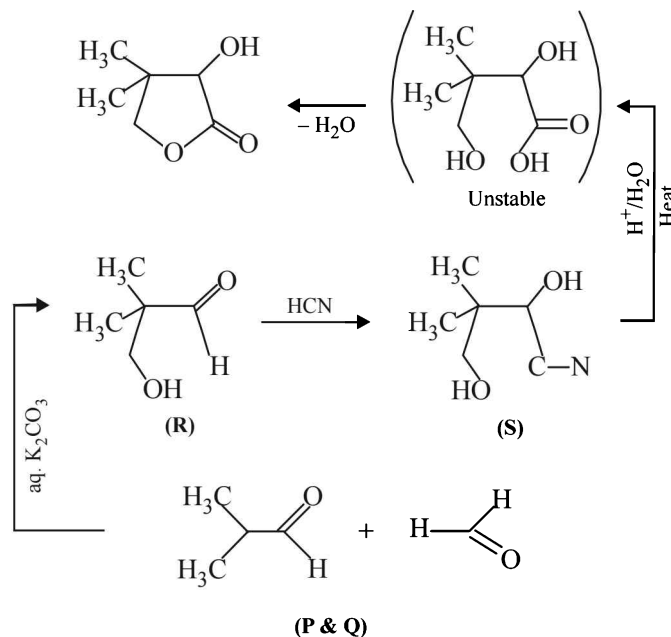

7. (b)

8. (a)

9. (d)

For 10 - 11

10. (c)

11. (a)

Reactions of compound **J** ( $C_9H_8O_2$ ) indicates that it has  $C=C$  linkage and  $-COOH$  group. Thus, **J** can be written as  $C_6H_5CH=CHCOOH$ . Since, **J** is unsaturated carboxylic acid and it is formed by the reactions of compound **I** with  $(CH_3CO)_2O$  and  $CH_3COONa$ , compound **I** should be an aldehyde (recall Perkin reaction). Thus the whole series of reactions can be written as below.

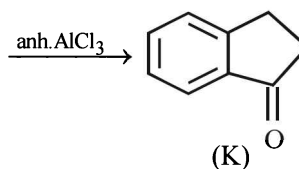
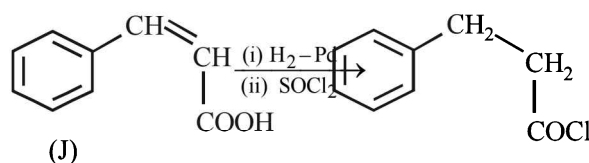

For 12-13.

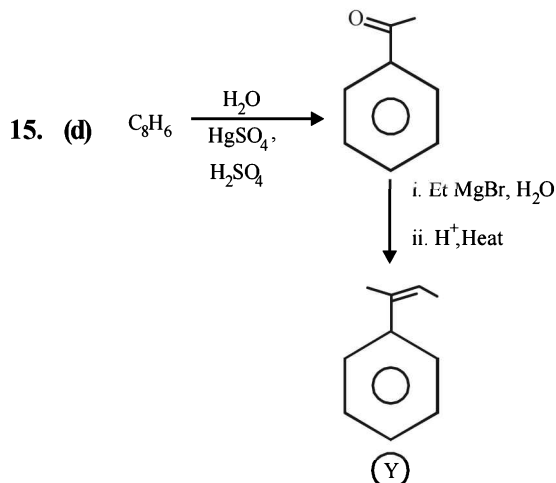
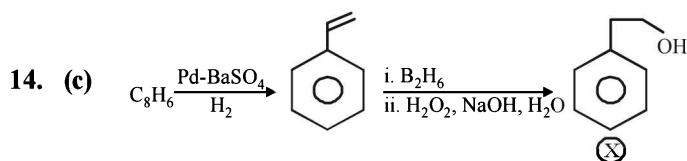
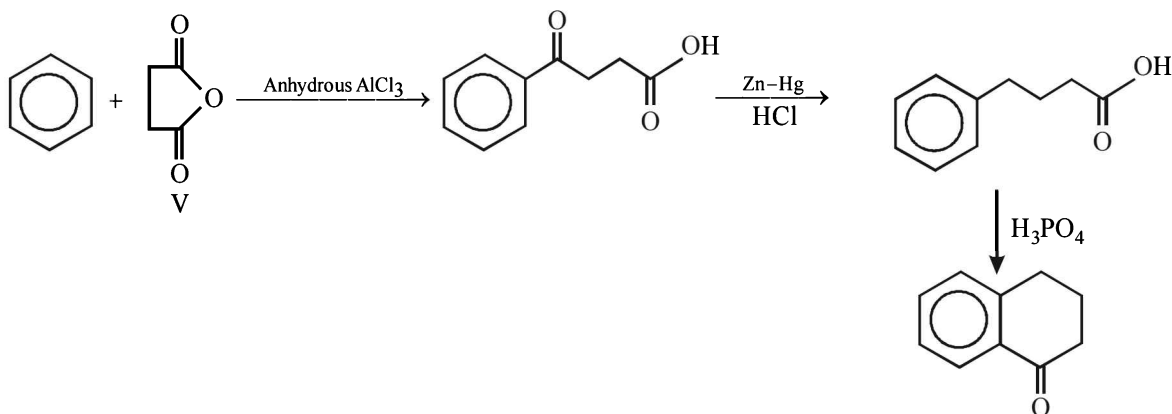
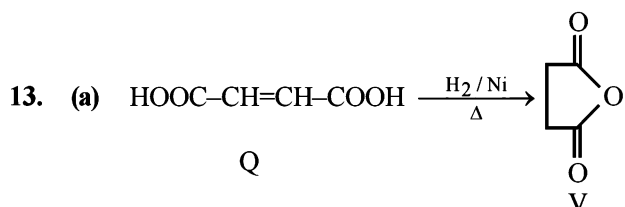
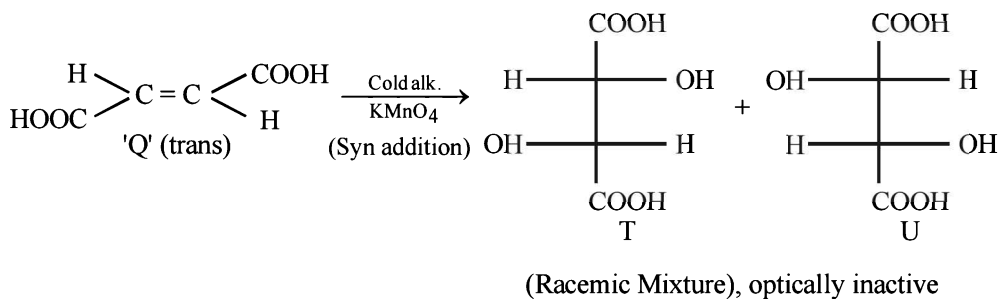
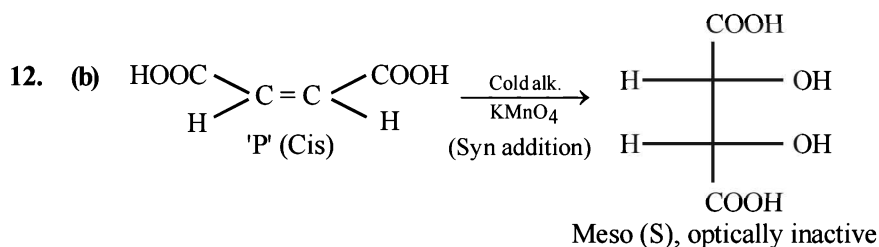

## H. Assertion &amp; Reason Type Questions

1. (d) **TIPS/Formulae :**  
 Acetate ion is resonance stabilized while methoxide ion is not.

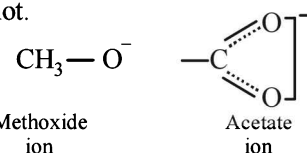

- Hence, acetate ion is less basic than methoxide ion.  
 2. (c) Haloform reaction is undergone only by ketones,  $\text{CH}_3\text{COOH}$  has 3  $\alpha$ -hydrogens.  
 3. (a) **TIPS/Formulae :**  
 Ozonide can be reduced by  $(\text{CH}_3)_2\text{S}$  to give carbonyl compounds and dimethyl sulphoxide.

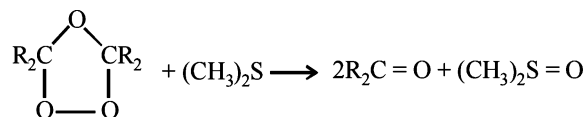

4. (d) *p*-Hydroxybenzoic acid has higher boiling point than *o*-hydroxybenzoic acid due to intermolecular hydrogen bonding. Thus, statement-1 is false. *o*-Hydroxybenzoic acid shows intramolecular H-bonding thus, statement-2 is true.

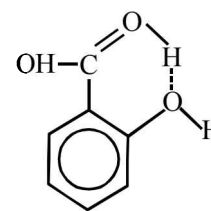

## I. Integer Value Correct Type

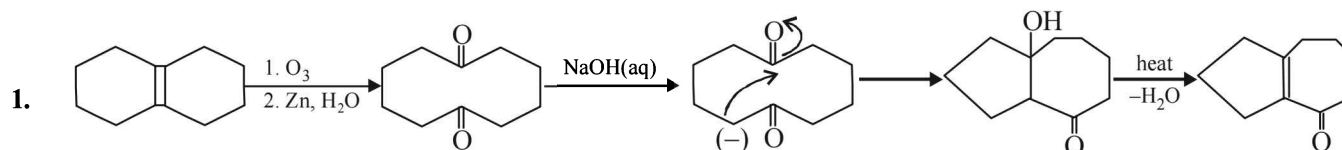

2. The number of intra molecular aldol condensation products ( $\alpha, \beta$ -unsaturated carbonyl compound formed from **Y** is 1.  
All carboxylic acids and phenols are soluble in aqueous NaOH. Four compounds are soluble in aqueous NaOH.

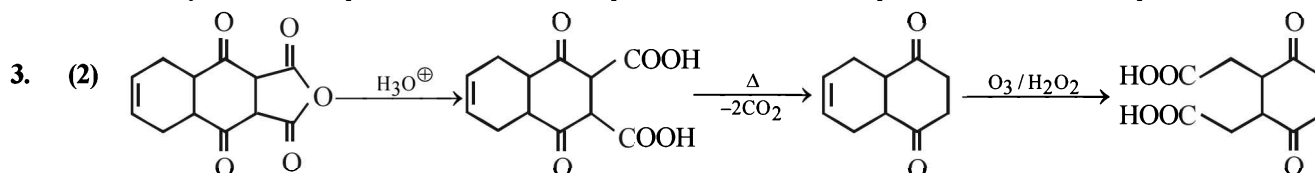

No. of  $-\text{COOH}$  group is '2'

4. (5) General molecular formula for ketones is  $\text{C}_n\text{H}_{2n}\text{O}$   
 $\therefore \text{C}_n\text{H}_{2n}\text{O} = 100$  or  $12n + 2n + 16 = 100, n = 6$   
Possible isomeric ketones with 6 carbon atoms are

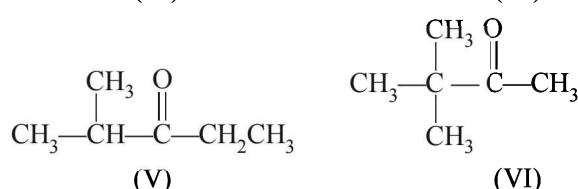
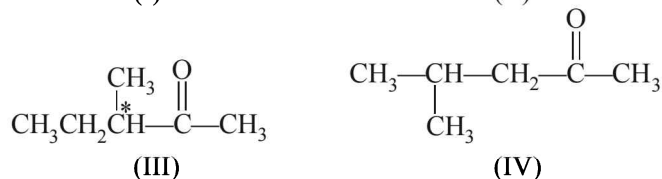
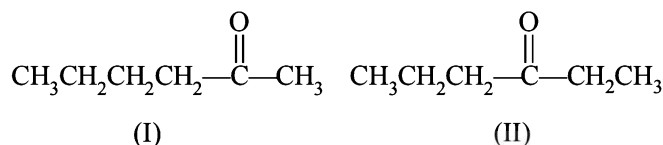

Note that only isomer III has a chiral carbon so on reduction with  $\text{NaBH}_4$  it will give diastereomeric alcohols, while all other five isomers will give racemic mixture.

5. (4)

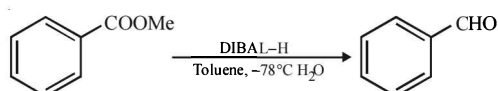
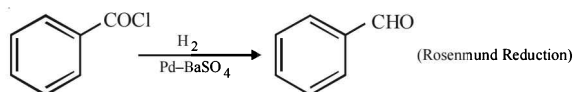
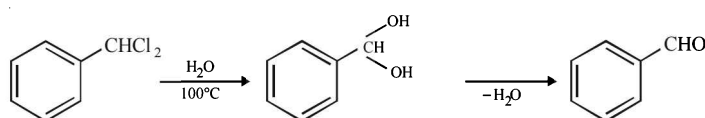
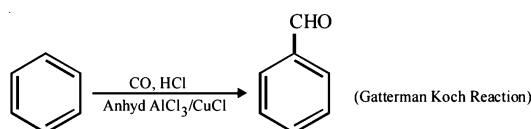

## Section-B

## JEE Main/ AIEEE

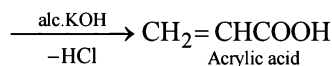
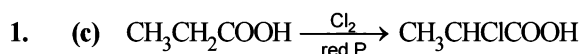

2. (b) Aldehydic group gets oxidised to carboxylic group. Double bond breaks and carbon gets oxidised to carboxylic group.

3. (c) 2,4,6-trinitrophenol is also known as picric acid.

4. (a)  $\text{LiAlH}_4$  can reduce COOH group and not the double bond.



5. (c) There is no reaction hence the resultant mixture contains  $\text{CH}_3\text{COOC}_2\text{H}_5 + \text{NaCl}$ .

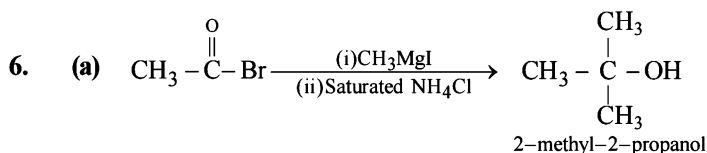

7. (d) It is Clemmensen's reduction

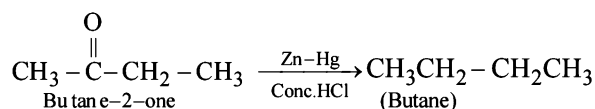

8. (b) This reaction is known as Cannizzaro's reaction. In this reaction benzaldehyde in presence of 50% NaOH undergoes disproportionation reaction and form one mol of Benzyl alcohol (Red. product) and one mole of sod. benzoate (ox. product)

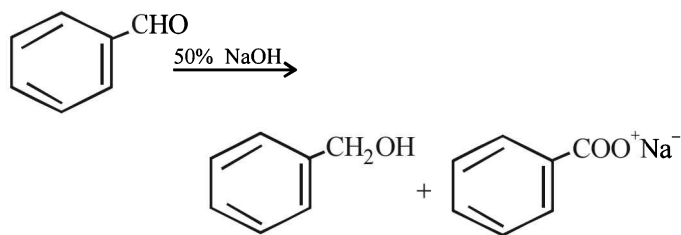

9. (c)  $pK_a = -\log K_a$ ; HCOOH is the strongest acid and hence it has the highest  $K_a$  or lowest  $pK_a$  value.

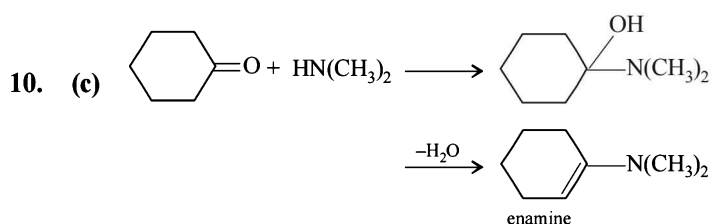

11. (a) **NOTE** : Addition of HCN to carbonyl compounds is nucleophilic addition reaction. The order of reactivity of carbonyl compounds is

Aldehydes (smaller to higher) Ketones (smaller to higher), Then

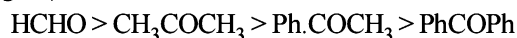

**NOTE** : The lower reactivity of Ketones is due to presence of two alkyl group which shows +I effect. The reactivity of Ketones decreases as the size of alkyl group increases.

12. (a) The correct order of increasing acid strength

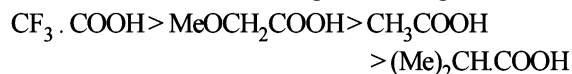

[**NOTE** : Electron withdrawing groups increase the acid strength and electron donating groups decrease the acid strength.]

13. (c) Fruity smell is due to ester formation which is formed between ethanol and acid.

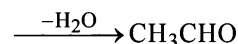
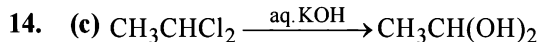
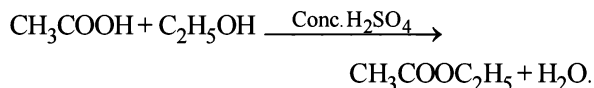

15. (a)

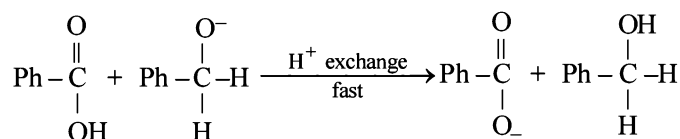
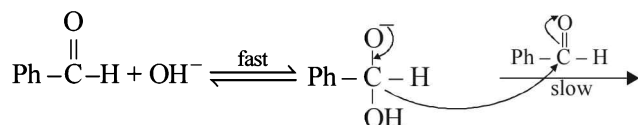

16. (d) Phenol gives a violet colour with neutral ferric chloride solution whereas benzoic acid does not give this test.

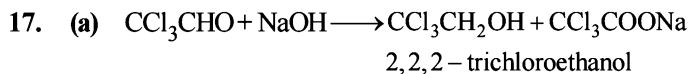

In Cannizzaro's reaction the compounds which do not contain  $\alpha$ -hydrogen atoms undergo oxidation and reduction simultaneously i.e. undergo disproportionation and form one molecule of sodium salt of carboxylic acid as oxidation product and one molecule of alcohol as reduction product.

18. (c) The electron withdrawing (-I) group -Cl withdraws electrons from O-H bond and thus helps the cleavage of the O-H bond releasing hydrogen as  $\text{H}^+$ .

## Aldehydes, Ketones and Carboxylic Acids

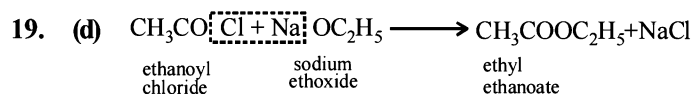

20. (a,c) Both formaldehyde and acetaldehyde give silver mirror with Tollen's reagent.

21. (d) Iodoform test is given by methyl ketones, acetaldehyde and methyl secondary alcohols.

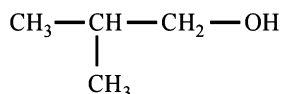

isobutyl alcohol is a primary alcohol hence doesn't give positive iodoform test.

22. (a) Aldehydes and ketones can be reduced to hydrocarbons by the action (i) of amalgamated zinc and concentrated hydrochloric acid (Clemmensen reduction), or (b) of hydrazine ( $\text{NH}_2\text{NH}_2$ ) and a strong base like NaOH, KOH or potassium *tert*-butoxide in a high-boiling alcohol like ethylene glycol or triethylene glycol (Wolf-Kishner reduction)

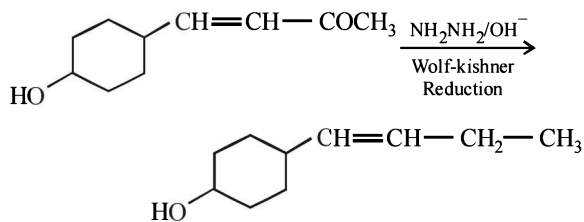

–OH group and alkene are acid-sensitive groups so clemmensen reduction can not be used. Acid sensitive substrate should be reacted in the Wolf-Kishner reduction which utilise strongly basic conditions.

23. (d) An excellent reagent for oxidation of 1° alcohols to aldehydes is PCC.

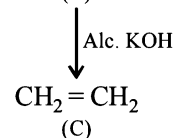
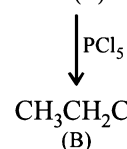
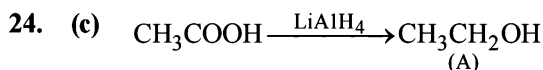
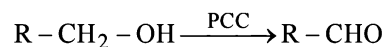

Hence the product (C) is ethylene.

25. (b)

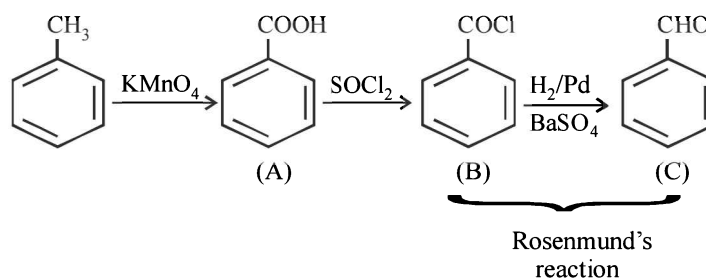

**Section-A : JEE Advanced/ IIT-JEE**

- A** 1. aniline 2. *o*-nitrophenol 3. dipolar ion
- C** 1. (c) 2. (b) 3. (b) 4. (a) 5. (b) 6. (a) 7. (b)  
 8. (d) 9. (b) 10. (c) 11. (d) 12. (b) 13. (a) 14. (a)  
 15. (a) 16. (d) 17. (b) 18. (b) 19. (NA) 20. (c) 21. (b)  
 22. (a) 23. (c)
- D** 1. (c, e) 2. (a, c) 3. (a, d) 4. (c) 5. (c) 6. (a, d) 7. (b)  
 8. (b, d) 9. (a, b, c) 10. (a, b, d) 11. (a) 12. (c) 13. (a) 14. (a) 15. (b)
- E** 3. (i) N, N-dimethyl-*p*-toluidine, < *p*-nitroaniline < aniline < *p*-toluidine.  
 (ii) aniline-N-methylamine < methylaniline < dimethylaniline  
 7. CH<sub>3</sub>CH<sub>2</sub>CONH<sub>2</sub>, CH<sub>3</sub>CH<sub>2</sub>COOH  
 8. aniline, phenol, phenyl isocyanide, salicylaldehyde, *p*-hydroxybenzaldehyde  
 A B C D E  
 9. isopropylamine 11. ethylmethylamine 12. PhNC  
 14. C<sub>6</sub>H<sub>5</sub>COCH<sub>3</sub>, *syn*-C<sub>6</sub>H<sub>5</sub>C(=NOH)CH<sub>3</sub>, *anti*-C<sub>6</sub>H<sub>5</sub>C(=NOH)CH<sub>3</sub>,  
 A B C  
 CH<sub>3</sub>CO.NHC<sub>6</sub>H<sub>5</sub>, CH<sub>3</sub>NHCOC<sub>6</sub>H<sub>5</sub>, C<sub>6</sub>H<sub>5</sub>NH<sub>2</sub>, C<sub>6</sub>H<sub>5</sub>COOH  
 D E F G
21. (CH<sub>3</sub>)<sub>2</sub>CH- $\overset{\text{NH}_2}{\underset{\text{X}}{\text{C}}}$ -CH<sub>3</sub>, (CH<sub>3</sub>)<sub>2</sub> $\overset{\text{OH}}{\underset{\text{Y}}{\text{C}}}$ -CH<sub>2</sub>CH<sub>3</sub>
- F** 1. (A)– p, q, s, t; (B)– s, t; (C) – p; (D) – r 2. (c)
- G** 1. (d) 2. (d) 3. (b) 4. (a) 5. (b)
- H** 1. (a) 2. (d) 3. (d) 4. (d)

**Section-B : JEE Main/ AIEEE**

1. (a) 2. (c) 3. (b) 4. (d) 5. (b) 6. (d) 7. (b)  
 8. (d) 9. (a) 10. (c) 11. (b) 12. (d) 13. (a) 14. (d)  
 15. (a) 16. (a) 17. (b)

**Section-A JEE Advanced/ IIT-JEE****A. Fill in the Blanks**

1. **aniline.**
2. ***o*-Nitrophenol;** this isomer involves intramolecular hydrogen bonding whereas the other two isomers have intermolecular hydrogen bonding. Because of this, the former is less polar and hence least soluble in polar solvent water.
3. **Dipolar ion.** (Salt like)

**C. MCQs with ONE Correct Answer**

1. (c) **NOTE :** *Secondary amines* (aliphatic as well as aromatic) *react with nitrous acid to form N-nitrosoamines.*  
 $(\text{C}_2\text{H}_5)_2\text{NH} + \text{HONO} \rightarrow (\text{C}_2\text{H}_5)_2\text{N}-\text{N}=\text{O} + \text{H}_2\text{O}$   
 N-Nitrosodiethylamine
2. (b)  $\text{CH}_3\text{CONH}_2 \xrightarrow{\text{NaOH} + \text{Br}_2} \text{CH}_3\text{NH}_2$   
 Acetamide Methylamine





–COOH > –OH (phenolic having NO<sub>2</sub> group) > –OH (phenolic) > alkylic H.

16. (d) **NOTE** : POCl<sub>3</sub> is a dehydrating agent. Hence

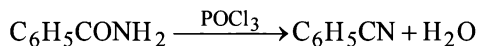

17. (b) **TIPS/Formulae** : –NH is an activating group whereas

as  $\text{>C=O}$  group is a deactivating group.

Hence electrophilic substitution will be governed by the ring having  $\text{>NH}$  group.

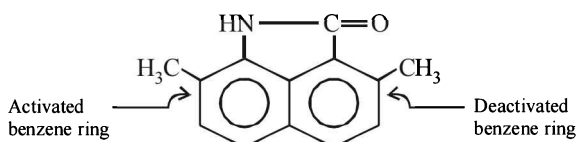

18. (b) (i) Position (X) is most acidic due to –COOH group.  
(ii) –NH<sub>3</sub><sup>+</sup> group at position Y is more acidic than at Z because of presence of electron withdrawing –COOH group in close proximity. Hence –NH<sub>3</sub><sup>+</sup> group at position Z is least acidic.

19. (NA) None of the given options is correct. Benzene sulphonic acid, being stronger acid than carbonic acid, would liberate CO<sub>2</sub> when treated with sodium bicarbonate, but *p*-nitrophenol, being less acidic than carbonic acid, will not liberate CO<sub>2</sub>.

20. (c) This is an example of carbylamine reaction

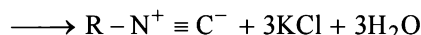

21. (b)  $\text{H}_2\text{C} = \text{N}^+ = \text{N}^- > \text{H}_2\text{C}^- - \text{N}^+ \equiv \text{N}$

I  
Octet complete,  
6 covalent bond,  
–ve charge on N

III  
Octet complete,  
6 covalent bond,  
–ve charge on C

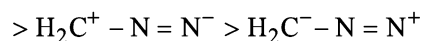

II  
Octet incomplete,  
5 covalent bond,  
–ve charge on N

IV  
Octet incomplete,  
5 covalent bond,  
–ve charge on C

22. (a)

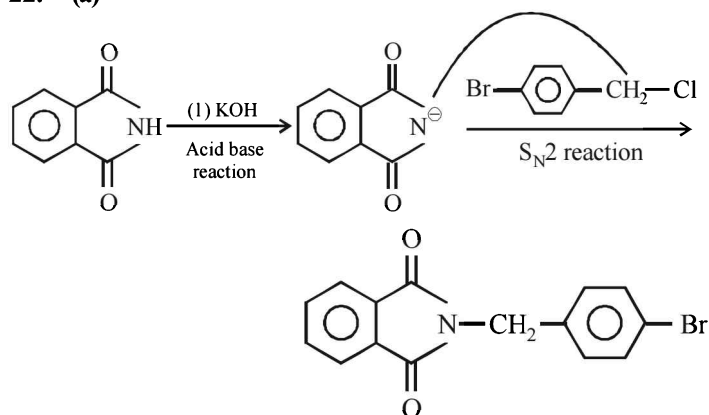

23. (c) Only primary aromatic amines undergo diazotisation followed by coupling.

## D. MCQs with ONE or More Than One Correct

1. (c, e) **TIPS/Formulae** : Silver nitrite, being a salt of nitrous acid, occurs in two tautomeric forms.

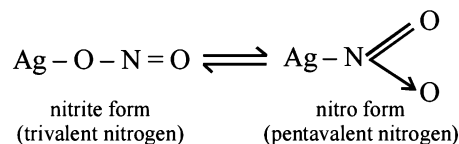

NO<sub>2</sub><sup>–</sup> ion from AgNO<sub>2</sub> may exist in two tautomeric forms, –O–N=O (nitrite ion) forming **alkyl nitrites**,

and  $\text{-N} \begin{array}{l} \diagup \text{O} \\ \diagdown \text{O} \end{array}$  (nitro group) forming **nitroalkanes**.

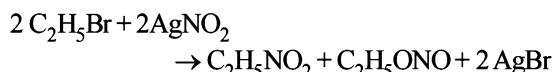

2. (a, c) This is an example of Hoffmann degradation of amides.

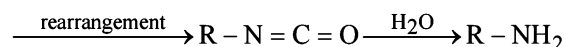
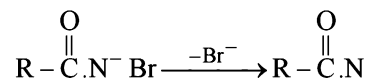
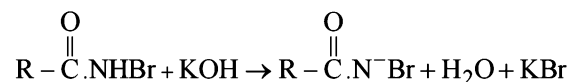
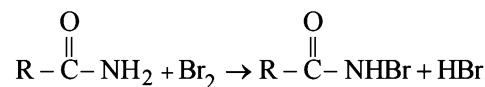

3. (a, d) **TIPS/Formulae** : Nitro group decreases the electron density at the *meta*-position in comparison to ortho and para position due to –I and –M effects.

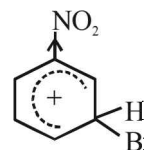

The above intermediate is a resonance hybrid of three structures, hence is more stable than the corresponding intermediate from *ortho* and *para*-attack.

4. (c) In I<sup>st</sup> structure N has complete octet, whereas in II<sup>nd</sup> structure N has 10e in its valence shell.

Because of 1 double and 3 single bonds of N.

5. (c) **TIPS/Formulae** : Anilinium hydrochloride has ionisable chlorine whereas chlorobenzene has non ionizable chlorine. Thus anilium hydrochloride gives white precipitate of AgCl with AgNO<sub>3</sub>.

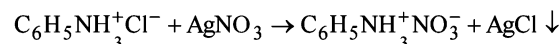

In chloroaniline, –Cl is directly attached to benzene ring, hence it is non-reactive.

6. (a, d)  $\text{C}_6\text{H}_5\text{NH}_2 + \text{O} = \text{C}(\text{CH}_3)_2 \xrightarrow{-\text{H}_2\text{O}} \text{C}_6\text{H}_5\text{N} = \text{C}(\text{CH}_3)_2$

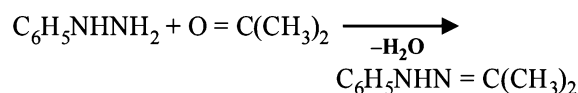

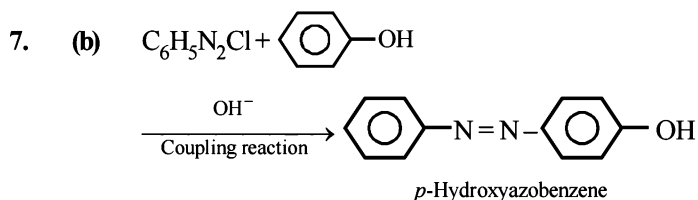

8. (b,d) **NOTE :** Only primary amines give carbylamine test. Hence 2,4-dimethylaniline and *p*-methyl-benzylamine both give this test.

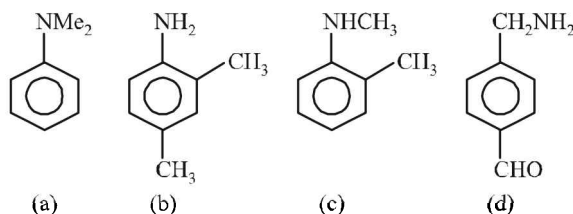

9. (a,b,c) Lower amines like  $NH_3$ ,  $CH_3NH_2$  and  $(CH_3)_2NH$  break diborane molecule unsymmetrically, while larger amines like  $(CH_3)_3N$ ,  $C_5H_5N$  break diborane in symmetrical manner.

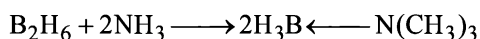
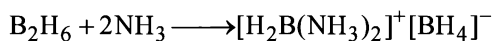

10. (a, b, d) In ice, water molecules are excessively H-bonded giving a cage-like structure which is lighter than water. Primary amines are more basic than tertiary amine, because the protonated  $1^\circ$  amines are extensively H-bonded and hence more stable than the corresponding protonated  $3^\circ$  amines.

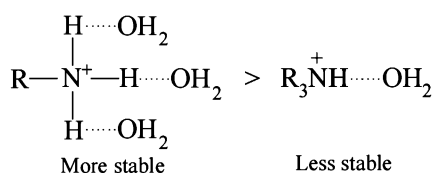
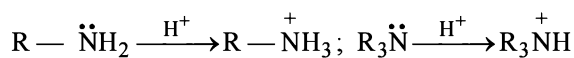

Acetic acid undergoes dimerisation in benzene.

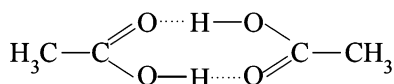

11. (a)  $-\ddot{N}H_2$  group is acetylated by acetic anhydride in methylene chloride (solvent). Note that  $-\text{CONH}_2$  group does not undergo acetylation because here lone pair of electrons is delocalised.

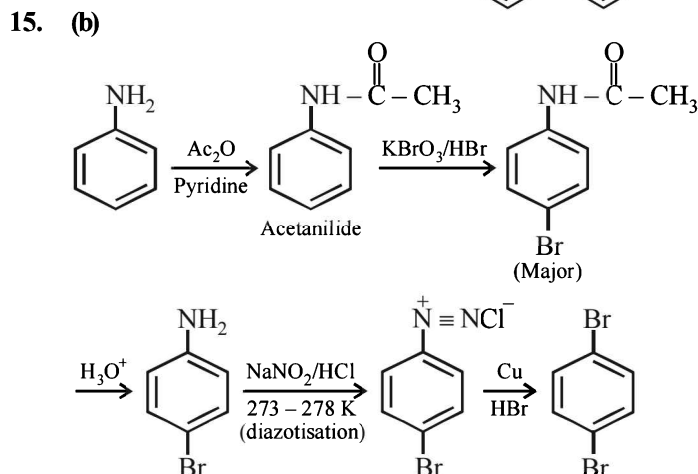
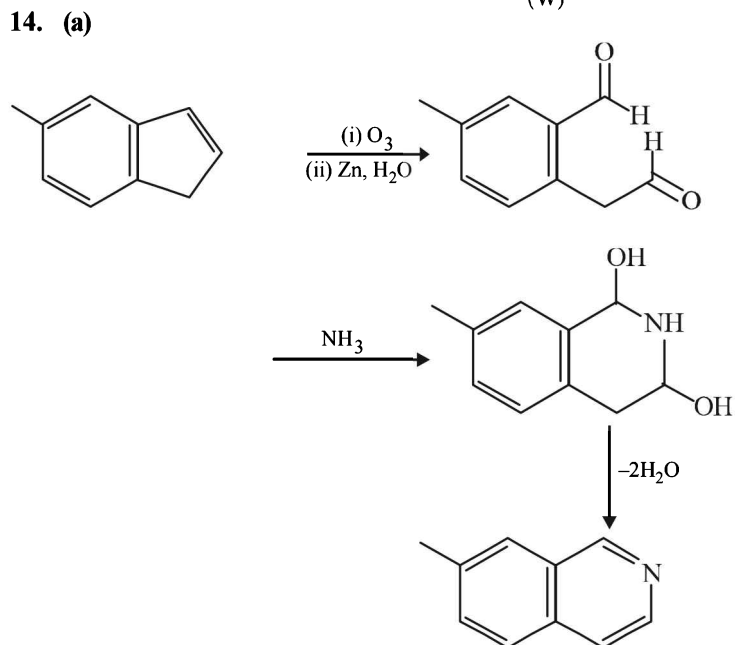
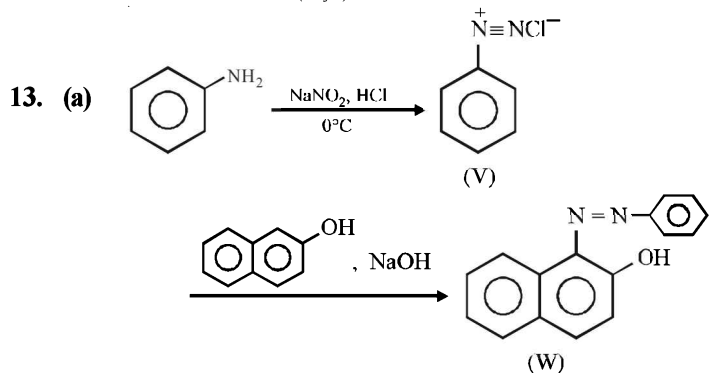
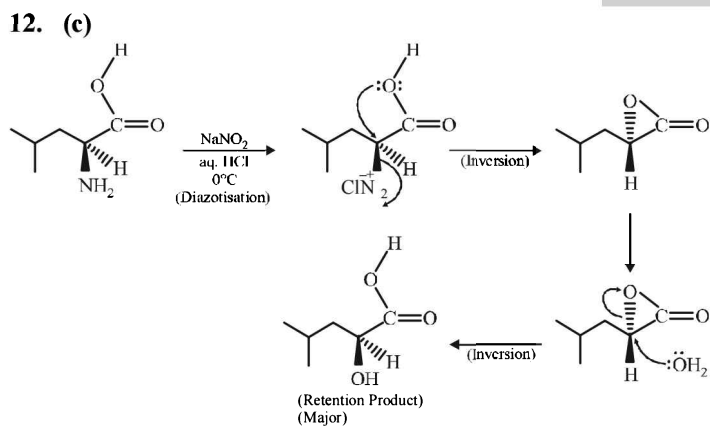
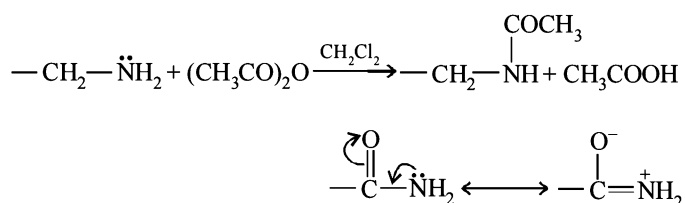

## E. Subjective Problems

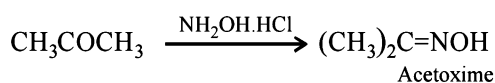
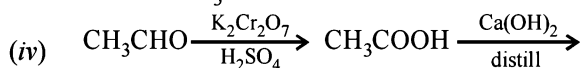
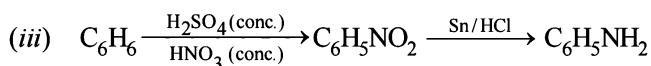
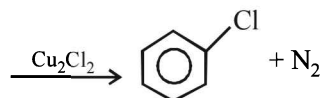
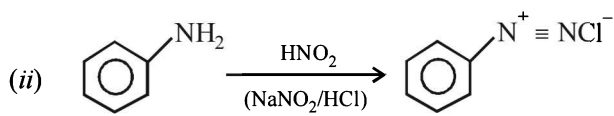
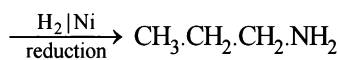
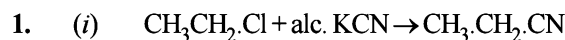

(v) Consult (ii)

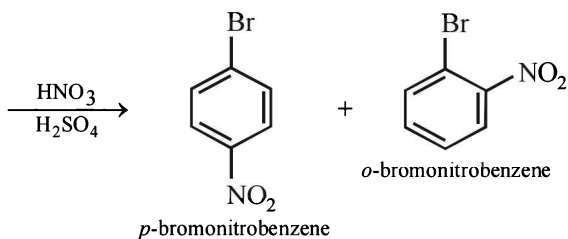
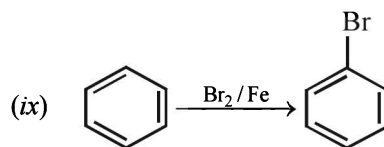
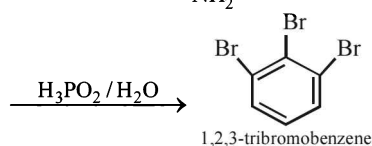
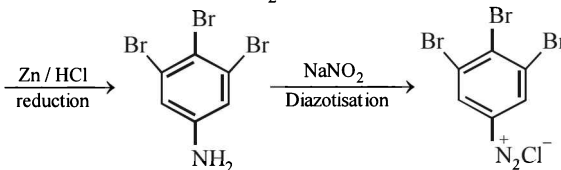
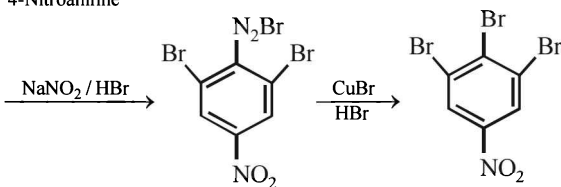
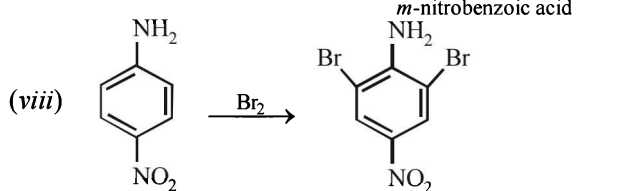
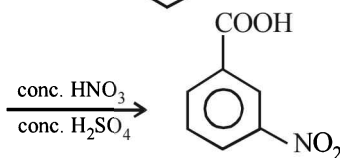
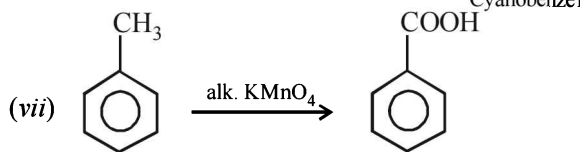
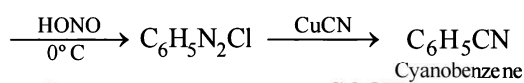
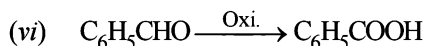

On fractional crystallization para isomer crystallizes first.

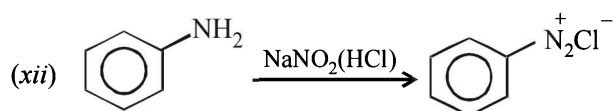
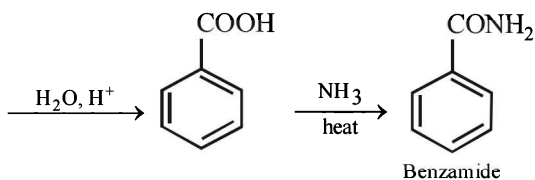
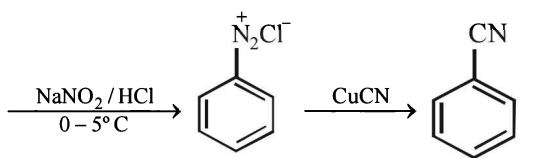
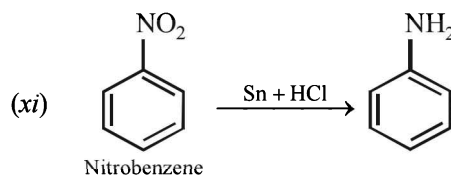
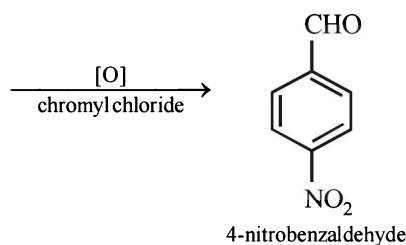
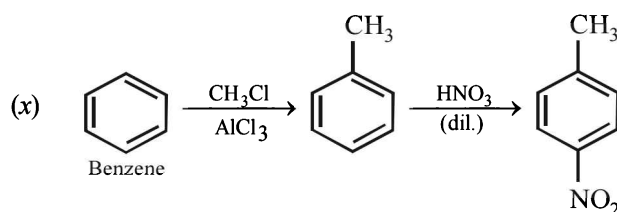

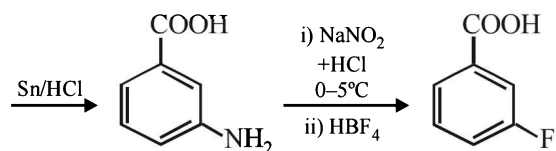
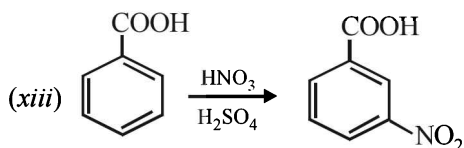
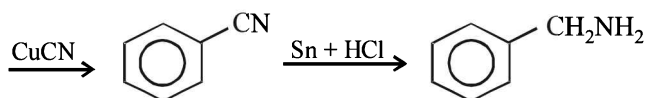

(xiv) Going backward, we can easily solve the problem.

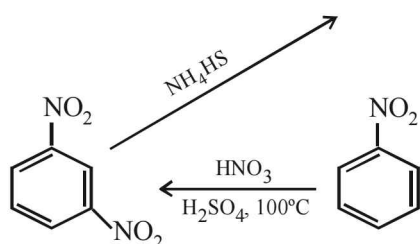
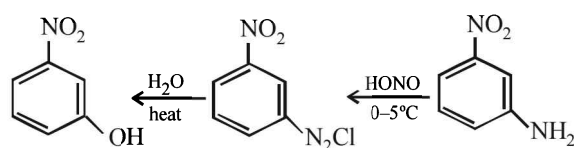

2. (i) Aniline is weak base than cyclohexylamine because of resonance while there is no resonance in cyclohexylamine.

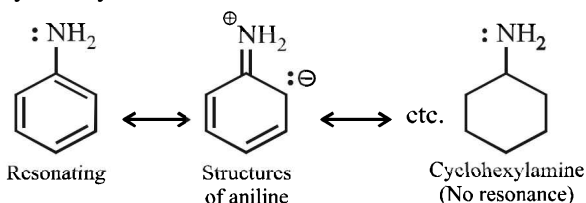

- (ii) *o*-nitrophenol shows intramolecular H-bonding and *p*-nitrophenol shows intermolecular H-bonding and thus its several molecules associate with each other. The *ortho* isomer goes with the steam due to its low boiling point.

- (iii) **TIPS/Formulae** : Two factors operate in deciding the basicity of alkyl amines.

(a) Inductive effect (b) Solvation effect

- (a) **Inductive effect.** The alkyl group being electron releasing increases the charge density on nitrogen. This in turn increases the basicity of amines. The expected order of basicity is  $R_3N > R_2NH > RNH_2 > NH_3$

- (b) **Solvation effect.** Because of the positive charge carried by the conjugate acid of an amine, it is

stabilised by the hydrogen bonding with the solvent water. The larger the number of hydrogens attached to the nitrogen in the conjugate acid, the larger is its stability and thus larger is the basicity of the corresponding base. The expected order of basicity of the alkylamines will be  $NH_3 > RNH_2 > R_2NH > R_3N$

The inductive and solvent effects predict the opposite trend in the basicity of alkyl amines. In going from  $R_2NH$  to  $R_3N$  the solvation effect plays a more dominating role as compared to the inductive effect making  $R_2NH$  more basic than  $R_3N$ .

A simple explanation is that the steric factor in  $R_3N$  makes the availability of a lone pair of electrons on nitrogen poor than in the dialkylamine, predicting  $R_2NH$  a stronger base than  $R_3N$ .

- (iv) The nitro group in nitrobenzene strongly deactivates the benzene ring due to  $-I$  and  $-M$  effects. This decreases the reactivity of benzene ring towards Friedel-Crafts alkylation.

- (v) **TIPS/Formulae** :  $-NO_2$  group is electron withdrawing, hence *m*-directing whereas  $-CH_2NO_2$  is not.

- (a) Given compound is an aryl fluoride having electron-withdrawing  $-NO_2$  group at *para* position of fluoride atom which activates the fluoride due to  $-M$  and  $-E$  effects for nucleophilic substitution ( $S_NAr$ ), hence reaction with NaOH will liberate  $F^-$  as NaF.

- (b) The given compound is an aryl fluoride having  $-CH_2NO_2$  group in the *meta* position which is not capable of activating aryl fluoride (absence of  $-M$  and  $-E$  effects because  $NO_2$  group is present in *m*-position and also not conjugated to benzene ring) for nucleophilic substitution, hence aq. NaOH will not displace fluorine here, i.e. no  $F^-$  will be formed.

- (vi) (a)  $-\ddot{N}=\ddot{O}$  group is electron releasing, hence *o*-, *p*-directing

- (b)  $-NO_2$  group is electron withdrawing, hence *m*-directing

3. (i) **TIPS/Formulae** : Presence of  $+I$  group increases the basicity whereas presence of  $-I$  group decreases the basicity.

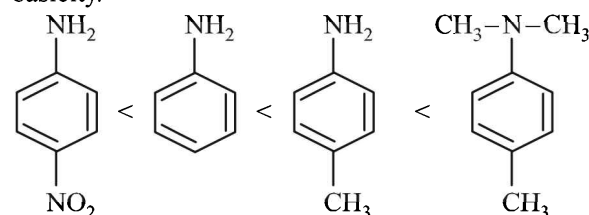

- (ii)

The ease with which the lone pair of electron (unshared) on the N-atom co-ordinates with a proton determines the relative basic strength of amines.

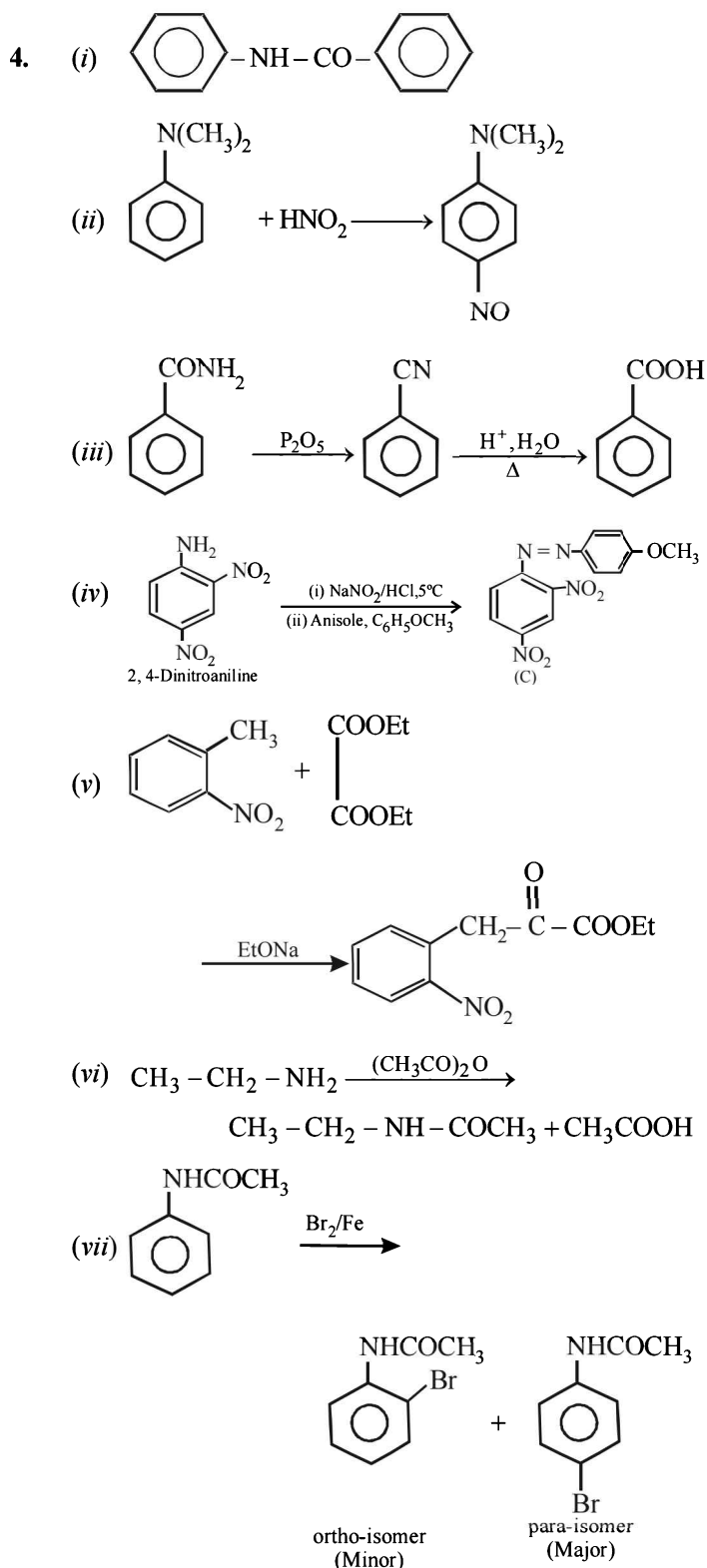

5. Hoffmann degradation reaction.

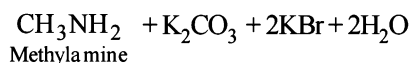
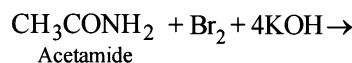

6. **NOTE :** Carbylamine reaction is a distinction test for primary amines. All primary amines (aliphatic or aromatic) on heating with alcoholic KOH and  $\text{CHCl}_3$  give unpleasant or foul smell of isocyanide which is easily detected.

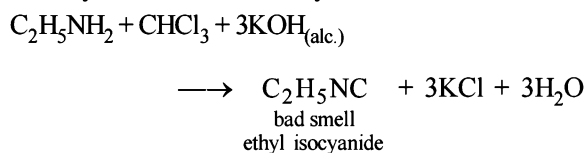

Diethylamine, a 2° amine, does not respond this test.

7. **Determination of empirical formula :**

	C	H	N	O
% age	49.32	9.59	19.18	21.91
mole	$\frac{49.32}{12}$	$\frac{9.59}{1}$	$\frac{19.18}{14}$	$\frac{21.91}{16}$
	=4.11	=9.59	=1.37	=1.37

**(Dividing by 1.37)**

Simplest ratio      3            7            1            1

∴ Empirical formula of A will be  $\text{C}_3\text{H}_7\text{NO}$  and empirical formula wt = 73

**Calculation of molecular wt. of (B)**

We know, meq. of Ag = meq. of Ag salt

$$\text{or } \frac{\text{Wt. of Ag}}{\text{Eq. wt. of Ag}} = \frac{\text{Wt. of salt}}{\text{Eq. wt. of salt}}$$

$$\text{or } \frac{59.67}{108} = \frac{100}{E_{\text{salt}}} \quad \text{or } E_{\text{salt}} = 181$$

$$E_{\text{salt}} = E_{\text{Ag}} + E_{\text{Anion}} \Rightarrow E_{\text{anion}} = 181 - 108 = 73$$

For monobasic acid (B), adding one H,

$$\text{Mol. wt.} = \text{Eq. wt.} + 1 = 73 + 1 = 74$$

B being monobasic can be represented as  $\text{C}_n\text{H}_{2n+1}\text{COOH}$   
 $\Rightarrow 74 = 12n + (2n + 1) \cdot 1 + 12 + 16 + 16 + 1 \Rightarrow n = 2$

∴ B =  $\text{C}_2\text{H}_5\text{COOH}$

**Nature of A :** Since B is obtained by the action of A with NaOH followed by hydrolysis, so A is an amide,  $\text{CH}_3\text{CH}_2\text{CONH}_2$ .

Reaction :

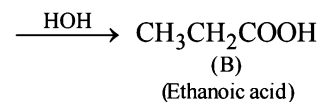
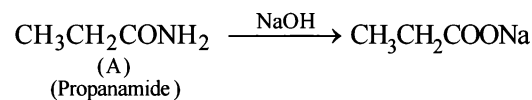

8. **TIPS/Formulae :**

(i) Carbylamine reaction involves reaction of a primary amine with alc. KOH and  $\text{CHCl}_3$  which results a product containing isocyanide group with unpleasant smell.

(ii) Reimer-Tiemann reaction of phenol produces *o* and *p* isomers.

Solution of compound A in chloroform when treated with alcoholic KOH yields compound C ( $C_7H_5N$ ) having an unpleasant odour which may be due to isocyanide. Hence the above reaction may be an example of carbylamine reaction. Therefore, compound A must be aniline ( $C_6H_5NH_2$ ) and C must be phenylisocyanide ( $C_6H_5NC$ ).

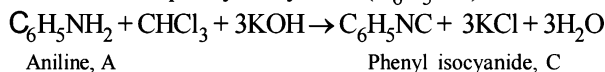

Alkaline aqueous layer of B when heated with chloroform gives D and E which are isomeric with each other and have molecular formula  $C_7H_6O_2$ . This indicates the possibility that Reimer-Tiemann reaction would have taken place. Hence compound B must be phenol and compounds D and E are *o*- and *p*-hydroxybenzaldehydes. This can be represented in the following way.

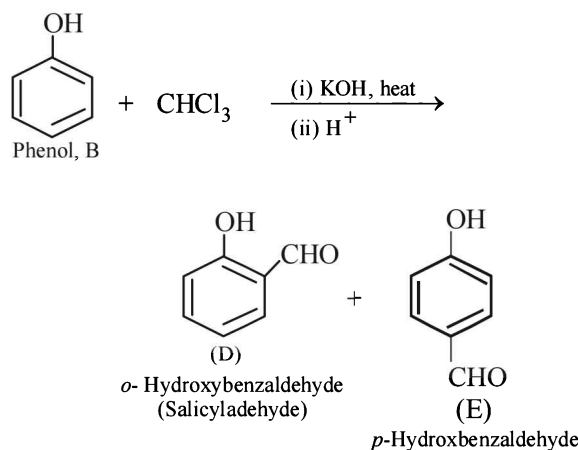

9. Let us summarise the given facts.

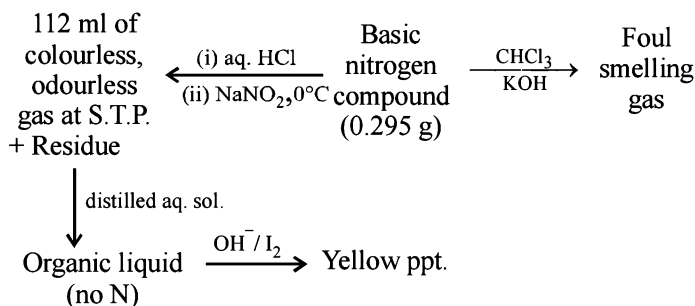

Reaction of the original compound with alcoholic potash and chloroform to give foul smelling gas indicates that it contains a primary  $-NH_2$  group.

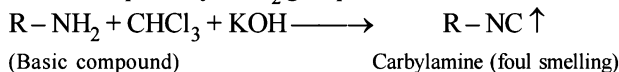

*Determination of mol. weight of the amine :*

112 ml. of gas is evolved at S.T.P. by 0.295 g of amine

$$22400 \text{ ml. of gas is evolved by } = \frac{0.295}{112} \times 22400 = 59$$

Hence the mol. wt. of the amine = 59

$\therefore$  Mol. wt. of the alkyl group = 59 - 16 = 43

Nature of alkyl gp. of mol. wt. 43 =  $C_3H_7-$

Thus the amine may be either

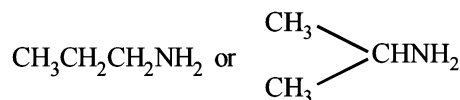

The reaction of amine with  $NaNO_2$  at  $0^\circ C$  and all other reactions may thus be written as below.

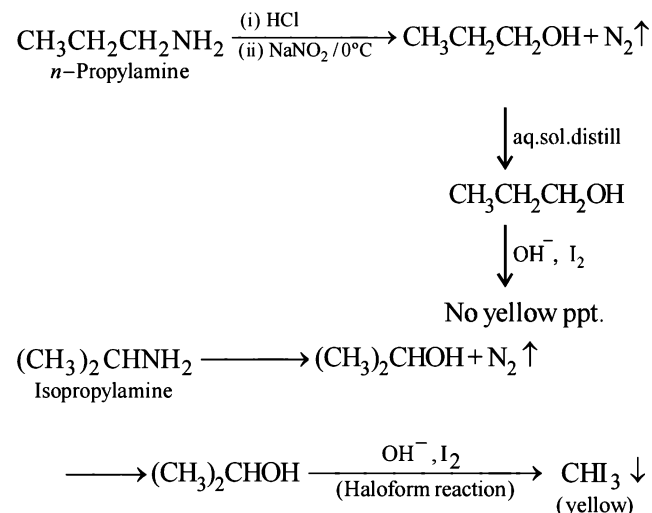

**NOTE :** Since the given reactions correspond to isopropylamine, the original compound may be propylamine or **isopropylamine**,  $(CH_3)_2CHNH_2$ .

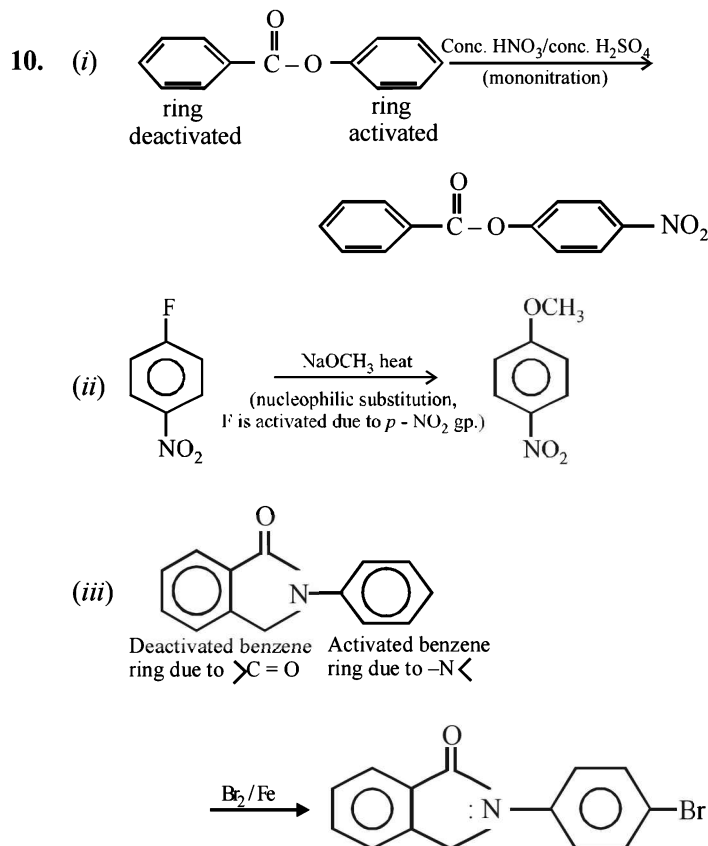

11. A ( $C_3H_9N$ ) is a 2° amine  $CH_3-NH-C_2H_5$  (ethylmethylamine) because the benzene sulphonyl chloride is solid and insoluble in alkali.

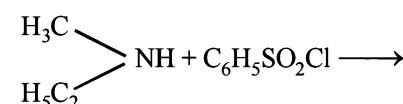

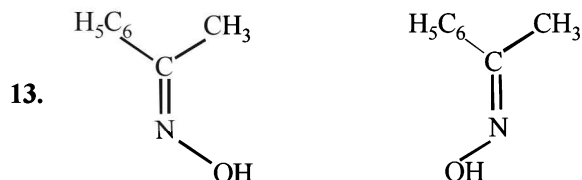
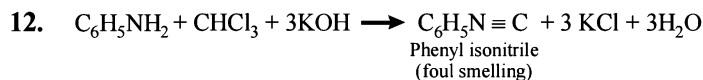
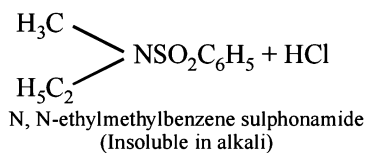

14. Summarise the given facts.

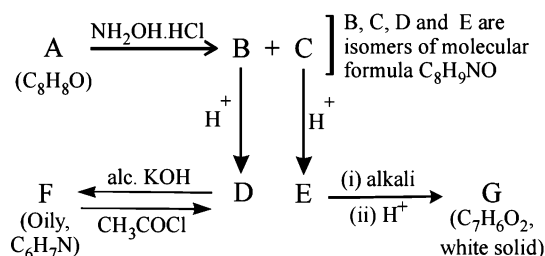

From the above set, following conclusions can be drawn.

(i) Since the oily compound F ( $\text{C}_6\text{H}_7\text{N}$ ) reacts with acetyl chloride, it must have  $-\text{NH}_2$  or  $>\text{NH}$  group. Thus (F) can be written as  $\text{C}_6\text{H}_5\text{NH}_2$  or  $\text{C}_6\text{H}_5\text{-NH-H}$ , i.e., it is  $\text{C}_6\text{H}_5\text{NH}_2$  and hence D is  $\text{C}_6\text{H}_5\text{NHCOCH}_3$ .

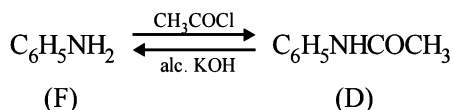

(ii) Compound E on treatment with alkali followed by acidification gives a white solid compound (G),  $\text{C}_7\text{H}_6\text{O}_2$ . Thus (G) seems to be an acid, hence it is  $\text{C}_6\text{H}_5\text{COOH}$ .

(iii) Since (D) and (E) are isomers of the formula  $\text{C}_8\text{H}_9\text{NO}$ , and give  $\text{C}_6\text{H}_5\text{NH}_2$  and  $\text{C}_6\text{H}_5\text{COOH}$  respectively, both should be amides having different alkyl or aryl group. Thus (D) should be  $\text{C}_6\text{H}_5\text{NHCOCH}_3$ , and (E) must be  $\text{CH}_3\text{NHCOC}_6\text{H}_5$ .

(iv) Since compounds (D) and (E) are formed by the rearrangement of compounds (B) and (C) respectively. Compounds (B) and (C) should be oximes  $>\text{C}=\text{NOH}$  (recall that oximes rearrange to amides - **Beckmann rearrangement**). Further oximes having different alkyl (aryl) groups show geometrical isomerism (*syn* and *anti*), compounds (B) and (C) must have following structures.



Recall that Beckmann rearrangement involves migration of *anti*-alkyl or aryl group, i.e.,

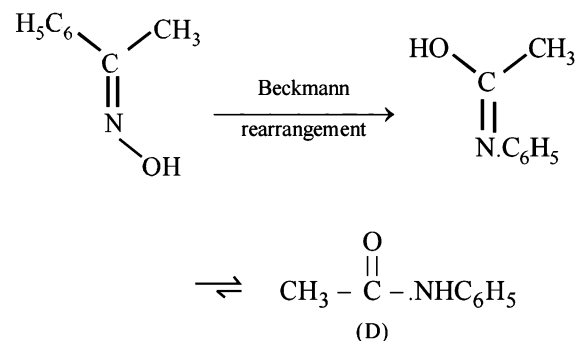

Since (D) is formed from (B), and (E) from (C), (B) and (C) should have following structures.

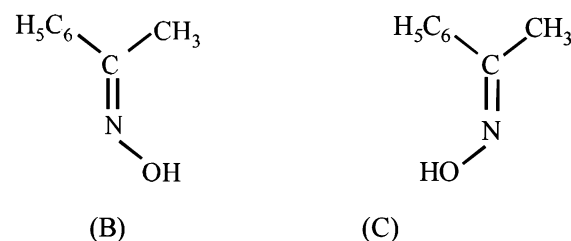

(v) Lastly, oximes (B) and (C) are formed from (A), the latter should be a ketone of the formula  $\text{C}_6\text{H}_5\text{COCH}_3$ ,

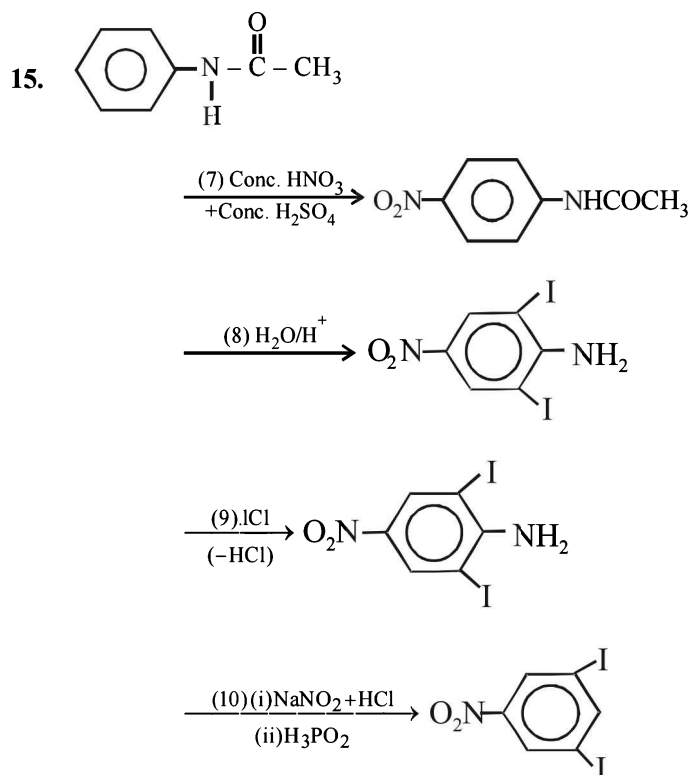
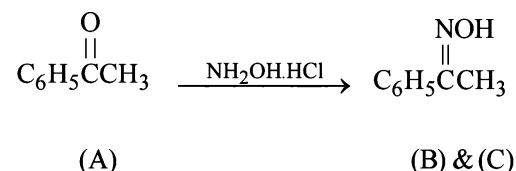



16. The reaction proceeds via benzyne formation

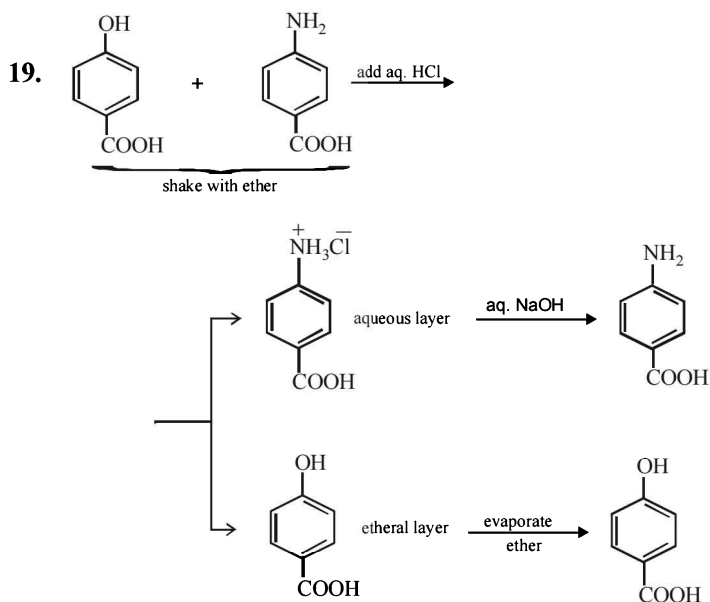
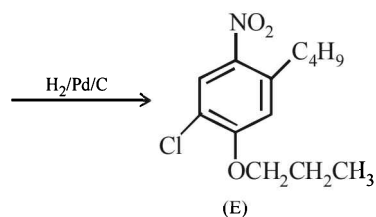
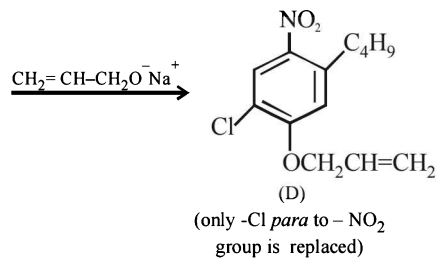
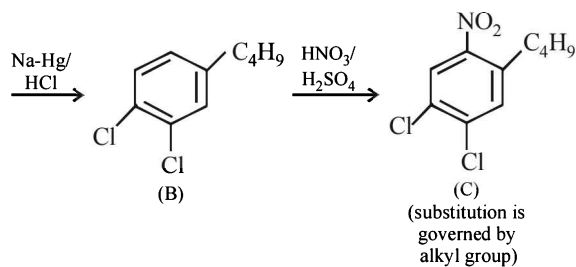
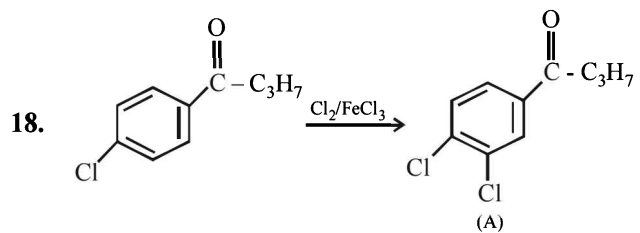
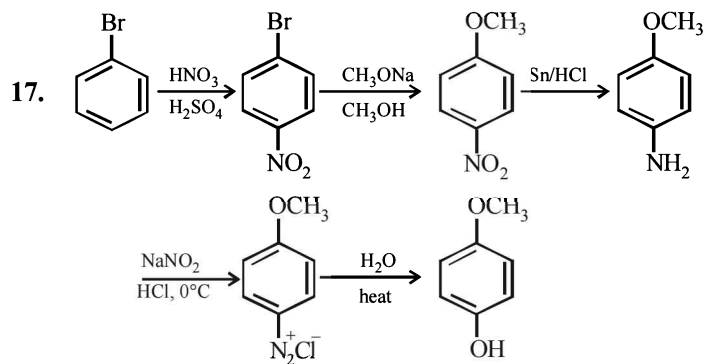
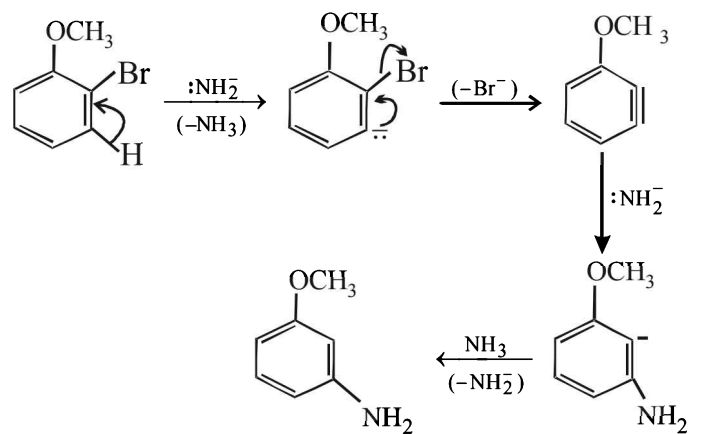

Test of phenolic group :

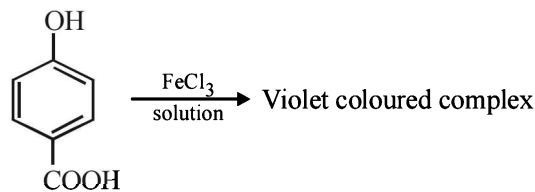

Test of 1° amino group :

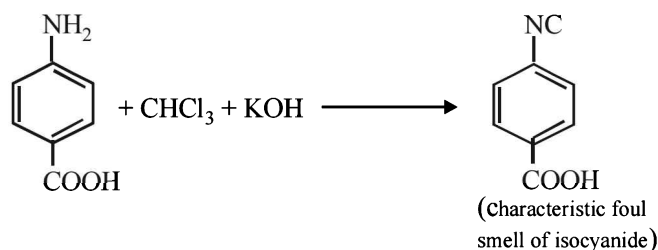

Test of -COOH group :

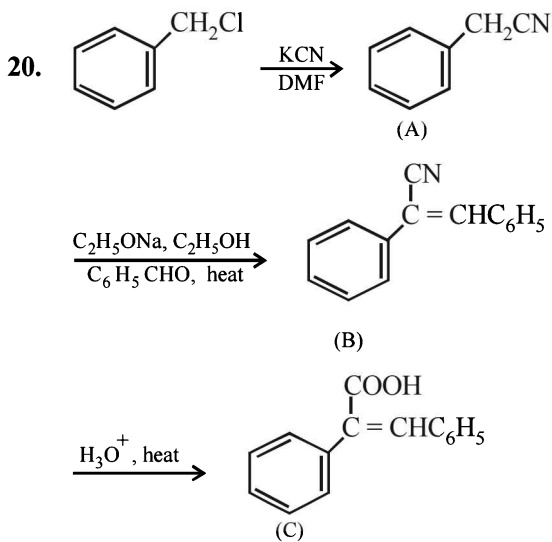
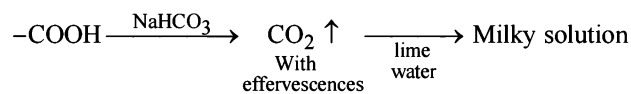

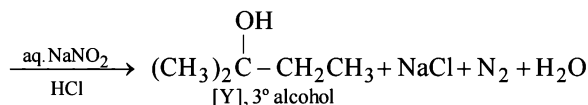
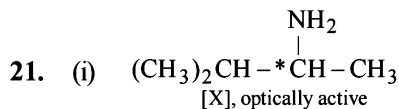
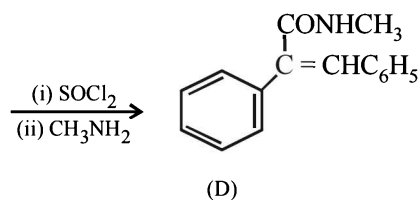

(ii) [Y], a 3° alcohol is optically inactive.

(iii) Formation of [Y] from [X].

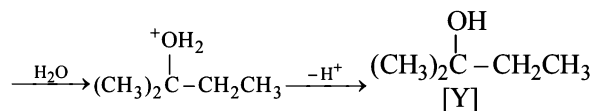
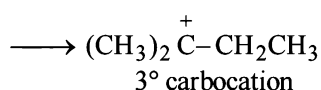
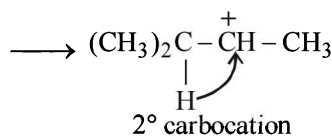
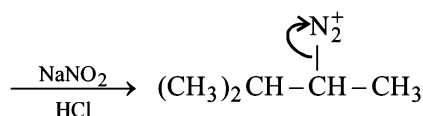
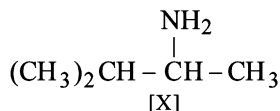

### F. Match the Following

1. (A)–p, q, s, t; (B)–s, t; (C)–p; (D)–r

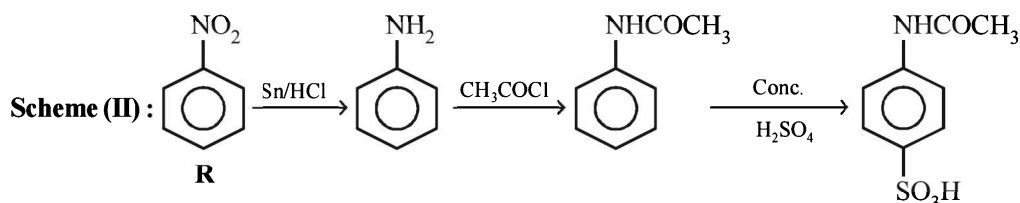
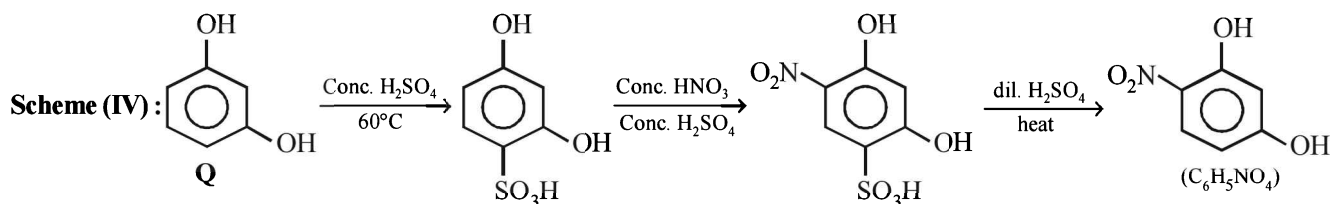
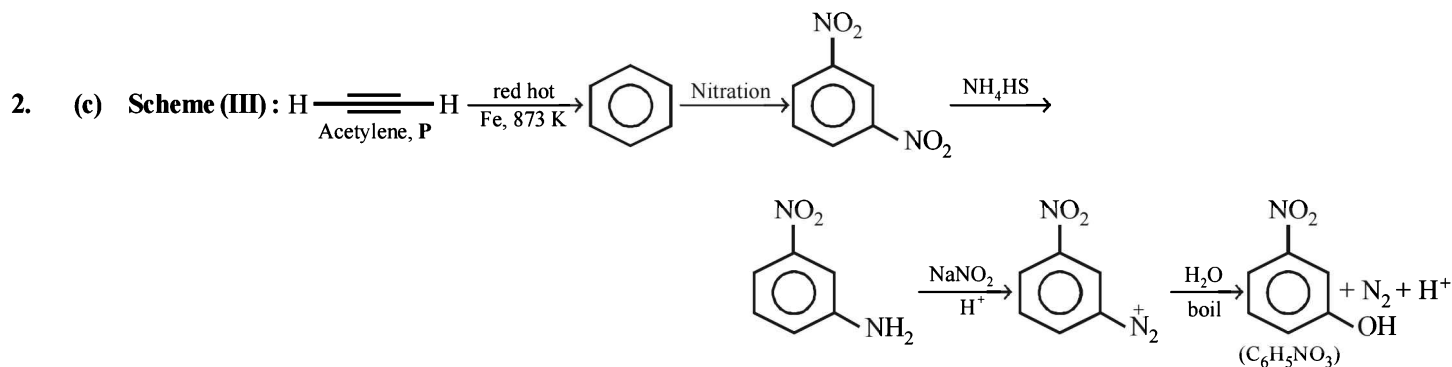
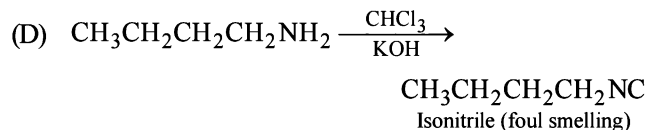
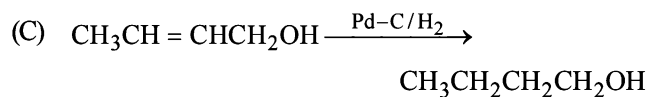
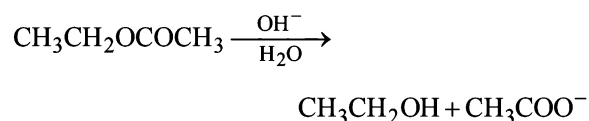
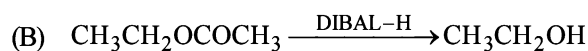
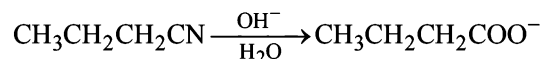
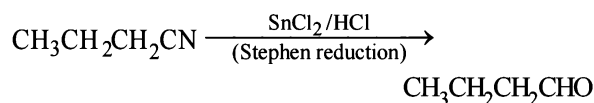
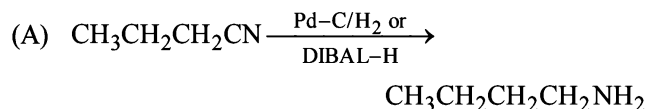

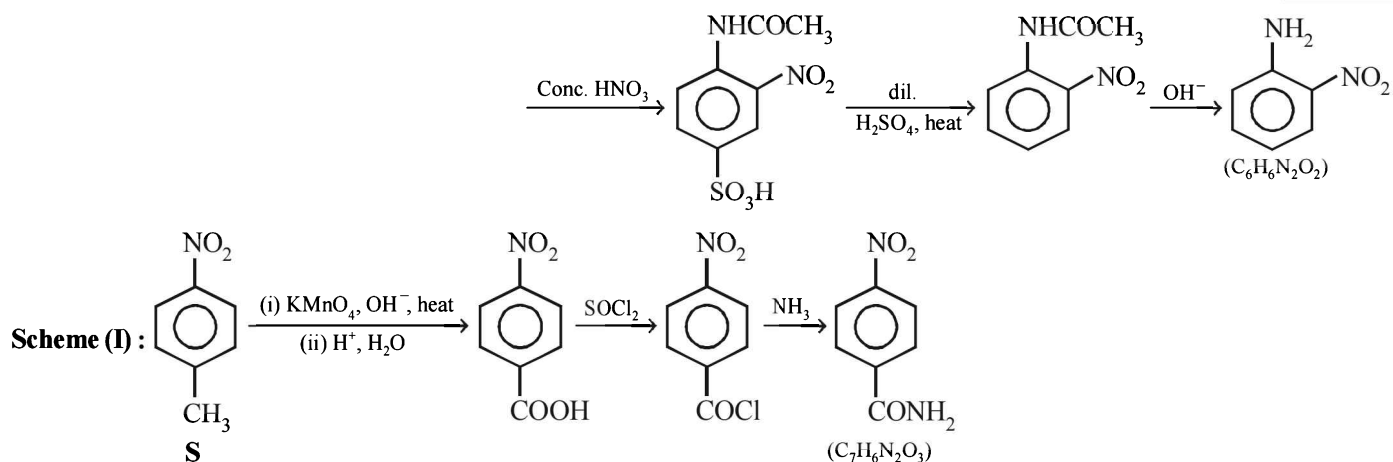

### G. Comprehension Based Questions

- (d) The reagent used in Hofmann bromamide reaction is alkaline halogen (NaOH or KOH + X<sub>2</sub>).
- (d) Conversion of (iii) to (iv) involving rearrangement is the slowest step. Species (iii) is electron deficient (N has only 6 electrons), hence it has a tendency to get its octet completed by migration of alkyl group.
- (b) Since the reaction is intramolecular, no cross product will be formed.

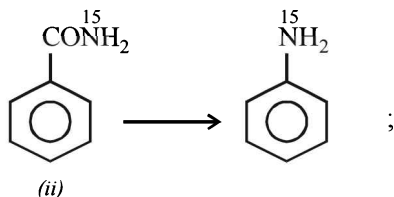
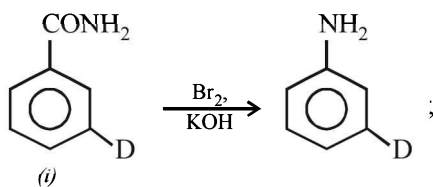

- (a)
- (b)

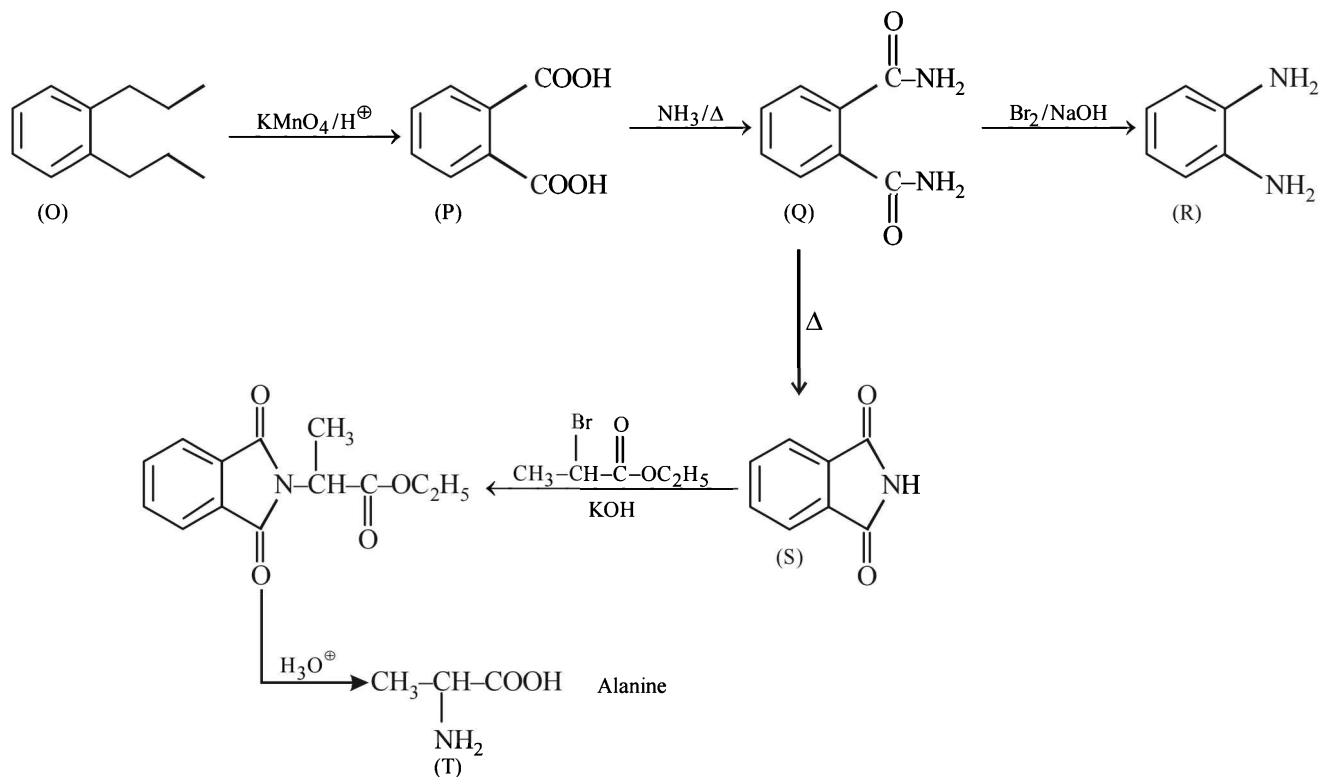

### H. Assertion & Reason Type Questions

- (a) In *o*-nitrophenol intramolecular H-bonding is possible because OH and NO<sub>2</sub> groups are close to each other. This makes the *ortho* isomer less acidic as its capacity to donate a proton (H-atom) decreases. There is no such intramolecular H-bonding in the *p*-isomer.
- (d) Chlorobenzene is resonance stabilized. Thus aryl halides (chlorobenzene) do not undergo nucleophilic substitution. Reason is correct.
- (d) **TIPS/FORMULAE** : Electron donating tendency to a double bond is called +M effect and the transfer of electrons take place towards the attacking reagent due to +E effect.  
In strongly acidic conditions, aniline becomes protonated with the result lone pair of electrons is not available to produce +E and +M effects. Thus here aniline becomes less reactive towards electrophilic

substitution. On the other hand, the  $-\text{NH}_3^{\oplus}$  group exerts strong  $-I$  effect causing deactivation of the

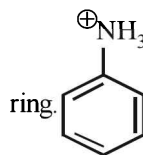

- (d) The colour of the azo dye formed will be orange red but not blue. However, the colour of dye can said to be due to extended conjugation due to presence of azo group.

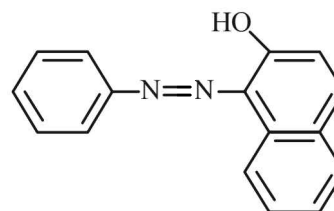

## Section-B JEE Main/ AIEEE

- (a)  $\text{C}_2\text{H}_5\text{NH}_2 + \text{CHCl}_3 + 3\text{KOH} \rightarrow \text{C}_2\text{H}_5\text{N}\equiv\text{C} + 3\text{KCl} + 3\text{HCl}$   
(Ethyl isocyanide)

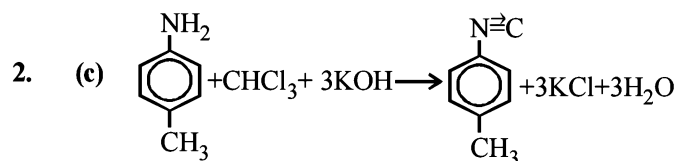

- (b) The alkyl groups are electron releasing group (+ I), thus increases the electron density around the nitrogen thereby increasing the availability of the lone pair of electrons to proton or lewis acid and making the amine more basic. Hence more the no. of alkyl group more basic is the amine. Therefore the correct order is  $\text{NH}_3 < \text{CH}_3\text{NH}_2 < (\text{CH}_3)_2\text{N}$
- (d) Ethyl isocyanide on hydrolysis form primary amines.

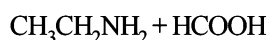
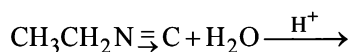

Therefore it gives only one mono chloroalkane.

- (b) Wurtz reaction is for the preparation of hydrocarbons from alkyl halide

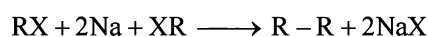

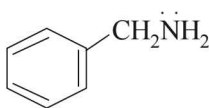
- (d) Benzylamine  is most basic. In others the basic character is suppressed due to Resonance (see applications of resonance).

Element	%	Relative number of atoms	Simple Ratio
C	20%	20/12 = 1.66	1.66 / 1.66 = 1
H	6.67%	6.67 / 1 = 6.67	6.67 / 1.66 = 4.16
N	46.67%	46.67/14 = 3.33	3.33 / 1.66 = 2.02
O	26.64%	26.64 / 16 = 1.66	1.66 / 1.66 = 1.0

The compound is  $\text{CH}_4\text{N}_2\text{O}$

$$\text{Empirical weight} = 60; \text{Mol. wt.} = 60; \therefore n = \frac{60}{60} = 1$$

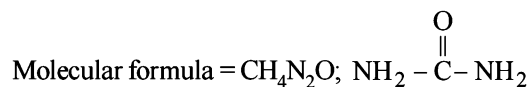

On heating urea loses ammonia to give Biuret

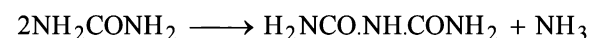

Biuret with alkaline  $\text{CuSO}_4$  gives violet colour. Test for  $-\text{CONH}-$  group.

- (d) **NOTE** : Aromatic amines are less basic than aliphatic amines. Among aliphatic amines the order of basicity is  $2^\circ > 1^\circ > 3^\circ$ . The electron density is decreased in  $3^\circ$  amine due to crowding of alkyl group over N atom which makes the approach and bonding by a proton relatively difficult. Therefore the basicity decreases. Further Phenyl group show  $-I$  effect, thus decreases the electron density on nitrogen atom and hence the basicity.  
 $\therefore$  dimethylamine ( $2^\circ$  aliphatic amine) is strongest base among given choices.  
 $\therefore$  The correct order of basic strength is Dimethylamine > Methyl amine > Trimethyl amine > Aniline.

9. (a) This is carbylamine reaction.

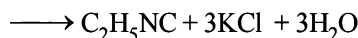
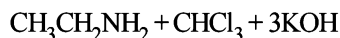

10. (c) Primary aromatic amines react with nitrous acid to yield arene diazonium salts.

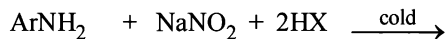

1° Aromatic amine

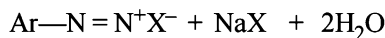

Arenediazonium salt

The diazonium group can be replaced by fluorine by treating the diazonium salt with fluoroboric acid ( $\text{HBF}_4$ ). The precipitated diazonium fluoroborate is isolated, dried and heated until decomposition occurs to yield the aryl fluoride. This reaction is known as **Balz-Schiemann reaction**.

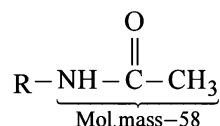
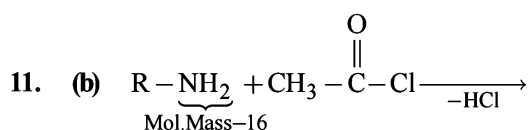
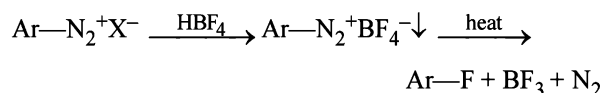

Now since the molecular mass increases by 42 unit as a result of the reaction of one mole of  $\text{CH}_3\text{COCl}$  with one  $-\text{NH}_2$  group and the given increase in mass is 210. hence the number of  $-\text{NH}_2$  group is  $= 210/42 = 5$

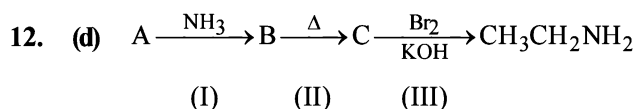

Reaction (III) is a Hofmann bromamide reaction formation of  $\text{CH}_3\text{CH}_2\text{NH}_2$  is possible only from a compound  $\text{CH}_3\text{CH}_2\text{CONH}_2$  which can be obtained from the compound  $\text{CH}_3\text{CH}_2\text{COO}^-\text{NH}_4^+$  (B) in (II) reaction further propanic acid ( $\text{CH}_3\text{CH}_2\text{COOH}$ ) on reaction with  $\text{NH}_3$  produce  $\text{CH}_3\text{CH}_2\text{COO}^-\text{NH}_4^+$  (reaction I) hence the reaction will be

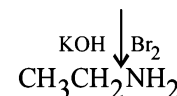
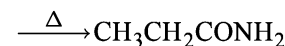
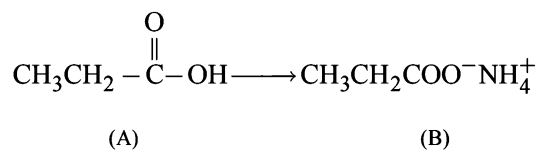

13. (a) Methyl isocyanate  $\text{CH}_3-\text{N}=\text{C}=\text{O}$

14. (d)  $\text{R}-\text{CH}_2-\text{NH}_2 + \text{CHCl}_3 + 3\text{KOH}(\text{alc}) \longrightarrow$

Carbylamine reaction

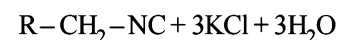

Alkyl isocyanide

15. (a) Arylamines are less basic than alkyl amines and even ammonia. This is due to resonance. In aryl amines the lone pair of electrons on N is partly shared with the ring and is thus less available for sharing with a proton.

In alkylamines, the electron releasing alkyl group increases the electron density on nitrogen atom and thus also increases the ability of amine for protonation. Hence more the no. of alkyl groups higher should be the basicity of amine. But a slight discrepancy occurs in case of trimethyl amines due to steric effect. Hence the correct order is

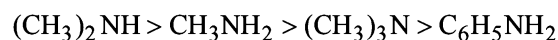

16. (a)

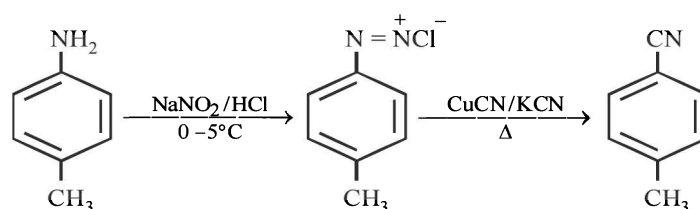

17. (b) 4 moles of  $\text{NaOH}$  and one mole of  $\text{Br}_2$  is required during production of one mole of amine during Hoffmann's bromamide degradation reaction.

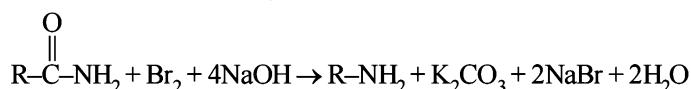

## Section-A : JEE Advanced/ IIT-JEE

- C** 1. (d)      2. (b)      3. (a)      4. (d)      5. (a)      6. (b)      7. (a)
- D** 1. (b, c)      2. (a, b, c, d)      3. (a)      4. (b, c)
- E** 3. (i) Amine, Carboxylic acid, Amide, Ester

[For answers of rest of the questions refer solutions]

- F** 1. (A) - p,s; (B) - q,r; (C) - p,r; (D) - s      2. (A) - r,s; (B) - t; (C) - p,q; (D) - r      3. (A) - p,s; (B) - p,q,r,t; (C) - p,q; (D) - p,q
- H** 1. (c)
- I** 1. 2      2. 6      3. 8      4. 4      5. 4      6. 1

## Section-B : JEE Main/ AIEEE

1. (a)      2. (b)      3. (c)      4. (b)      5. (b)      6. (b)      7. (b)      8. (c)
9. (b)      10. (a)      11. (c)      12. (c)      13. (b)      14. (c)      15. (b)      16. (a)
17. (b)      18. (c)      19. (d)      20. (c)      21. (c)      22. (b)      23. (c)      24. (a)
25. (b)      26. (b)      27. (b)      28. (c)      29. (c)      30. (a)      31. (a)      32. (a)
33. (a)      34. (c)      35. (a)      36. (d)      37. (a)      38. (d)      39. (b)

## Section-A JEE Advanced/ IIT-JEE

### C. MCQs with ONE Correct Answer

- (d) Glucose being an aldose responds to Tollen's test while fructose, although a ketose, undergoes rearrangement in presence of basic medium (provided by Tollen's reagent) to form glucose, which then responds to Tollen's test.
- (b) The two isomeric forms (a - and b -) of D-glucopyranose differ in configuration only at C-1; hence these are called anomers.
- (a) Cellulose is a polysaccharide composed of only D-glucose units. Every adjacent glucose units are joined by  $\beta$ -glycosidic linkage between C<sub>1</sub> of one glucose and C<sub>4</sub> of the next.

**NOTE :** Thus in every glucose units only three -OH groups are free to form triacetate.

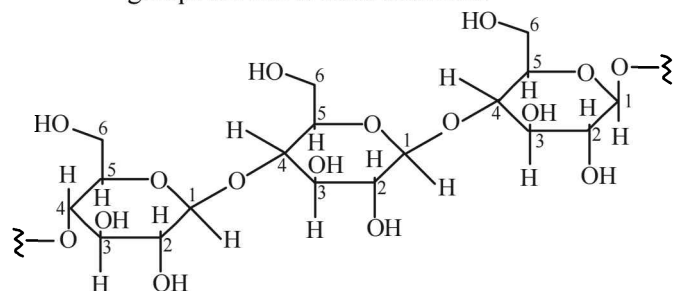

Cellulose triacetate

$(\text{CH}_3\text{CO})_2\text{O}$ ,  $\text{H}_2\text{SO}_4$

$(-\text{OH} = -\text{OCOCH}_3)$

- (d) Nylon and cellulose, both have intermolecular hydrogen bonding, polyvinyl chloride has dipole-dipole interaction, while natural rubber has van der Waal forces which are weakest.

- (a)

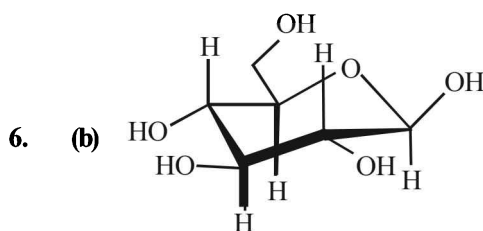

It is a  $\beta$ -pyranose hence it is an aldohexose.

- (a)

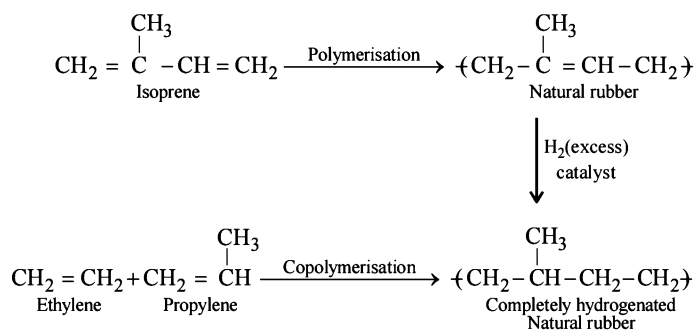

### D. MCQs with ONE or More Than One Correct

- (b,c) We know that carbohydrates having acetal linkage are non-reducing while that with hemiacetal linkage are reducing. In the give structure,

X has acetal linkage, hence non-reducing.

Y has hemiacetal linkage, hence reducing.

Further X is  $\alpha$ -anomer, while Y is  $\beta$ -anomer of D-(+)-glucose.

2. (a,b,c,d)

Condensation polymers are formed by condensation of a diol or diamine with a dicarboxylic acid.

Hence, X may be  $-\overset{\text{O}}{\parallel}{\text{C}}-\text{OR}$  or  $-\overset{\text{O}}{\parallel}{\text{C}}-\text{NH}_2$  or  $-\text{C}\equiv\text{N}$

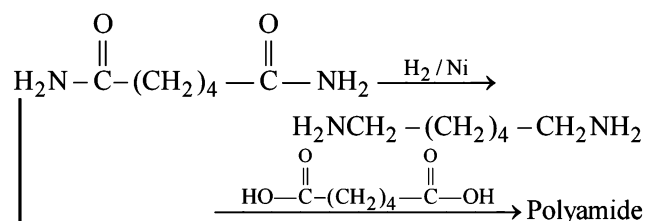
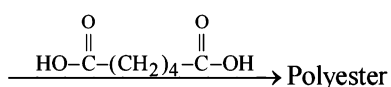
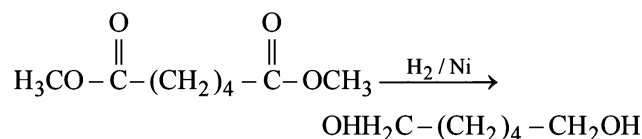

$\text{Br}_2/\text{OH}^-$ ,  $\Delta$   
Hofmann bromamide reaction

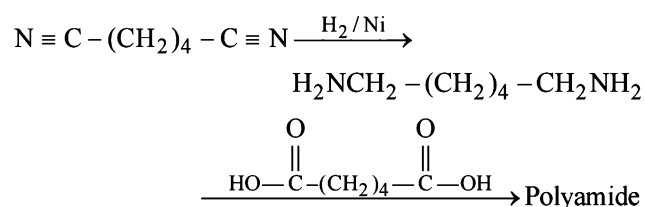
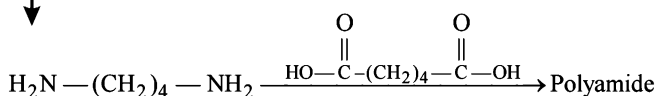

3. (a)

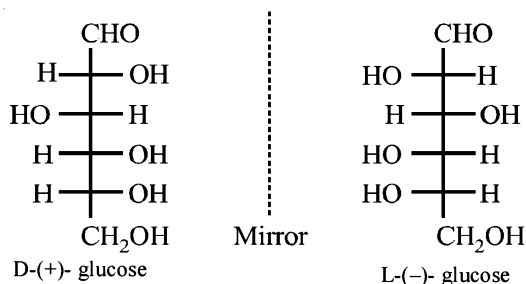

4. (b, c)

Invert sugar is an equimolar mixture of D-(+) glucose and D(-) glucose.

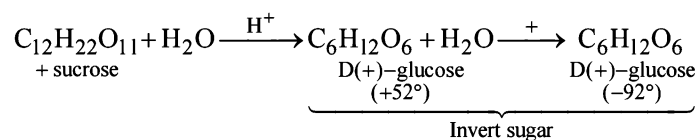

- Specific rotation of invert sugar =  $\frac{-92^\circ + 52^\circ}{2} = -20^\circ$
- D-glucose on oxidation with  $\text{Br}_2$ -water produces gluconic acid and not saccharic acid.

## E. Subjective Problems

1. (i) Sucrose  $\longrightarrow$

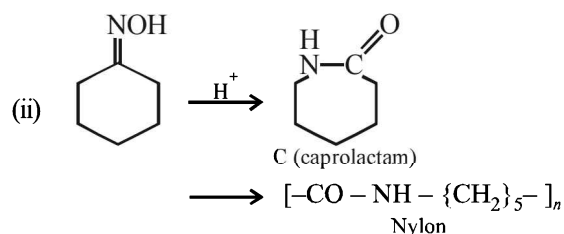
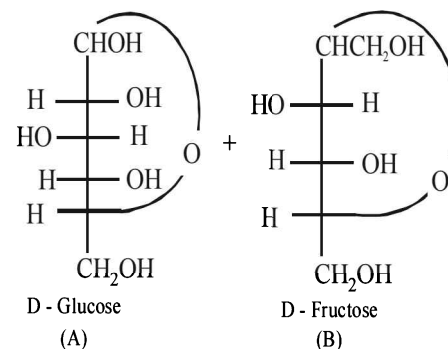

2. TIPS/Formulae :

pH = 2 indicates acidic character whereas pH = 10 indicates basic character.

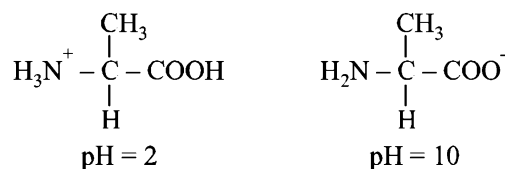

3.

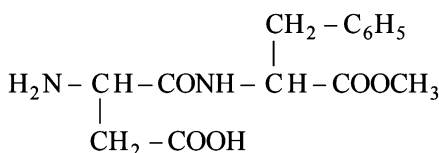

Aspartame (Aspartamine)

(i) Four functional groups present in aspartamine are

- (a)  $-\text{NH}_2$  (Amine)  
(b)  $-\text{COOH}$  (Carboxylic acid)

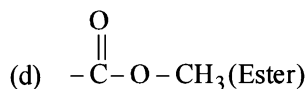
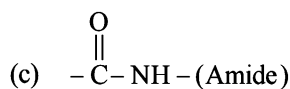

(ii) Zwitterion structure is given as follows :

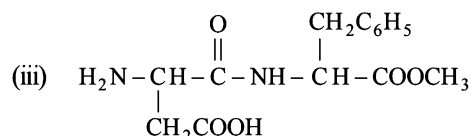
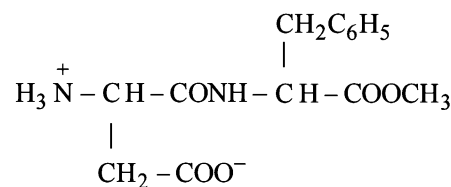

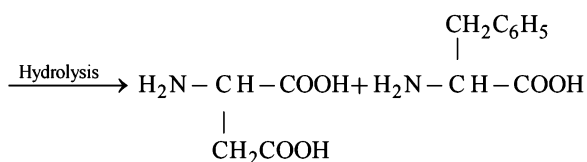

Hence on hydrolysis two amino acids (a) and (b) are obtained.

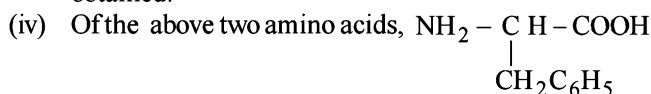

is more hydrophobic due to presence of non-polar and bulky benzyl group.

4. The structure of two possible dipeptides are

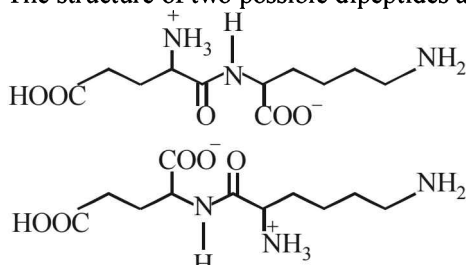

5. L-Glucose is an enantiomer of D-glucose, hence

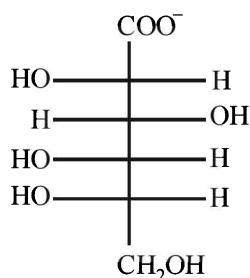
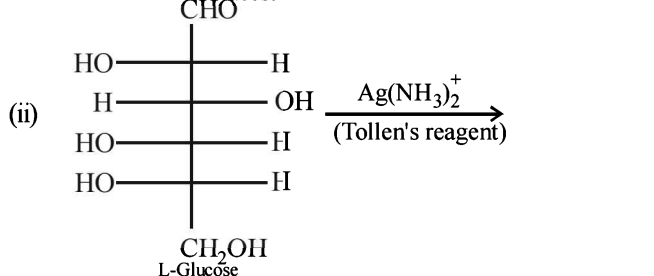
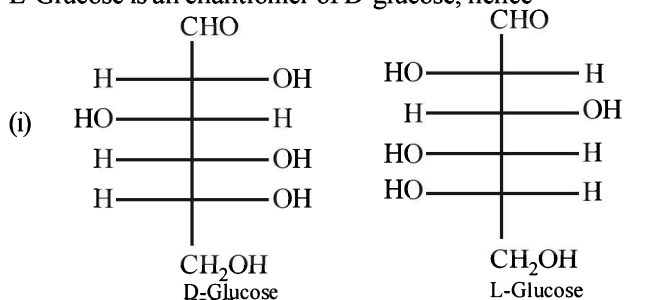

6. In the two disaccharides structure A will be reducing sugar since both monosaccharide units are not linked through their reducing centers, while in structure B both the monosaccharide units are linked through their reducing centers, hence it will be non-reducing.

### F. Match the Following

- (A) : (p) and (s) Cellulose is a natural polymer and has a  $\text{C}_1-\text{C}_4$   $\beta$ -glycosidic linkage.  
(B) : (q) and (r) Nylon-6, 6 is a synthetic polymer of hexamethylenediamine and adipic acid and has amide linkages.

(C) : (p) and (r) Proteins are natural polymers of  $\alpha$  amino acids joined by amide linkages (peptide bonds).

(D) : (s) Sucrose is a disaccharide of  $\alpha$ -D glucose and  $\beta$ -D-fructose and has an  $\alpha, \beta$ -glycosidic linkage.

- (A) – (r), (s); (B) – (t); (C) – (p), (q); (D) – (r)

### H. Assertion & Reason Type Questions

- (c) Statement-1 is correct, but statement-2 is incorrect because glucose on reaction with Fehling solution gives  $\text{Cu}_2\text{O}$  and not  $\text{CuO}$ .

### I. Integer Value Correct Type

- The basic groups in the given form of lysine is  $\text{NH}_2$  (not  $\text{NH}_3^+$ ) and  $\text{CO}_2^-$ .

2. 6

Molecular weight of decapeptide = 796 g/mol  
Total bonds to be hydrolysed =  $(10 - 1) = 9$  per molecule  
Total weight of  $\text{H}_2\text{O}$  added =  $9 \times 18 = 162$  g/mol  
Total weight of hydrolysis products =  $796 + 162 = 958$  g  
Total weight % of glycine (given) = 47%

Total weight of glycine in product =  $\frac{958 \times 47}{100} \text{ g} = 450 \text{ g}$

Molecular weight of glycine = 75 g/mol

Number of glycine molecules =  $\frac{450}{75} = 6$

3. (8)

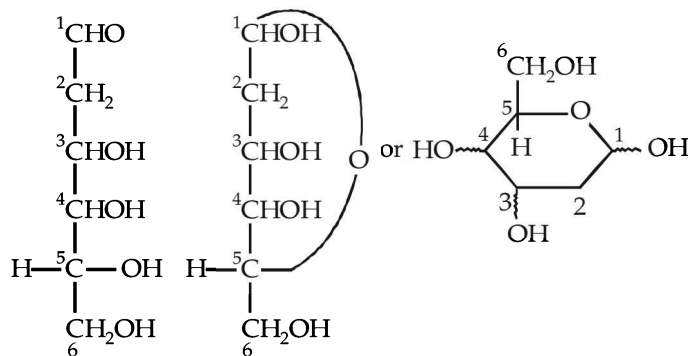

D- Aldohexose

D- Aldohexopyranose

Thus, total number of stereoisomers in pyranose form of D-configuration =  $2^3 = 8$

- (4) Peptides with isoelectric point (pI) more than 7, would exist as cation in neutral solution (pH=7) which means the given polypeptide is of basic nature, so it must contain two or more amino groups. Hence IV, VI, VIII and IX are correct options.
- (4) According to question C – Terminal must be alanine and N – Terminal do have chiral carbon means it should not be glycine. So possible sequence is :  
Val Phe Gly Ala  
Val Gly Phe Ala  
Phe Val Gly Ala  
Phe Gly Val Ala
- (1) On hydrolysis, the given peptide gives only one naturally occurring amino acid (glycine).



## Section-B JEE Main/ AIEEE

- (a) Polymerisation starts either by condensation or addition reactions between monomers. Condensation polymers are formed by the combination of monomers with the elimination of simple molecules. Whereas the addition polymers are formed by the addition together of the molecules of the monomer or monomers to form a large molecule without elimination of any thing.
- (b) In RNA, the sugar is D-ribose and base is uracil where as in DNA, the sugar is D-2 de oxyribose and the nitrogenous base is thymine.
- (c) The given compound is aspirin which is antipyretic and analgesic
- (b) Liquid hydrogen and liquid oxygen are used as excellent fuel for rockets.  $H_2(l)$  has low mass and high enthalpy of combustion whereas oxygen is a strong supporter of combustion.
- (b) Nylon is a polyamide polymer.
- (b) Cellulose is a linear polymer of  $\beta$ -D-glucose in which  $C_1$  of one glucose unit is connected to  $C_4$  of the other through  $\beta$ -D glucosidic linkage. It does not undergo hydrolysis easily. However on heating with dilute  $H_2SO_4$  under pressure. It does undergo hydrolysis to give only D-glucose.
 
$$(C_6H_{10}O_5)_n + nH_2O \xrightarrow{H^+} nC_6H_{12}O_6$$

D-Glucose
- (b) DNA consists of two polynucleotide chains, each chain forms a right handed spiral with ten bases in one turn of the spiral. The two chains coil to double helix and run in opposite direction held together by hydrogen bonding.
- (c) RNA contains cytosine and uracil as pyrimidine bases while DNA has cytosine and thymine. Both have the same purine bases i.e., Guanine and adenine.
- (b) Insulin is a biochemically active peptide hormone secreted by pancreas.
- (a) Photochemical smog is caused by oxides of sulphur and nitrogen.
- (c) Nylon is a general name for all synthetic fibres forming polyamides.
- (c) An antipyretic is a drug which is responsible for lowering the temperature of the feverish organism to normal but has no effect on normal temperature states.
- (b) In DNA and RNA heterocyclic base and phosphate ester are at  $C_1'$  and  $C_5'$  respectively of the sugar molecule.

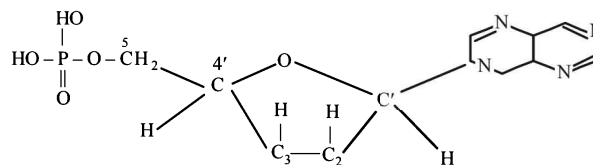

- (c) Teflon is polymer of  $CF_2=CF_2$ .
- (b) Cyclization of the open chain structure of D-(+)-glucose has created a new stereocenter at  $C_1$  which explains the existence of two cyclic forms of D-(+)-glucose, namely  $\alpha$ - and  $\beta$ -. These two cyclic forms are *diastereomers*, such diastereomers which differ only in the configuration of chiral carbon developed on hemiacetal formation (it is  $C_1$  in glucose and  $C_2$  in fructose) are called **anomers** and the hemiacetal carbon ( $C_1$  or  $C_2$ ) is called the **anomeric carbon**.

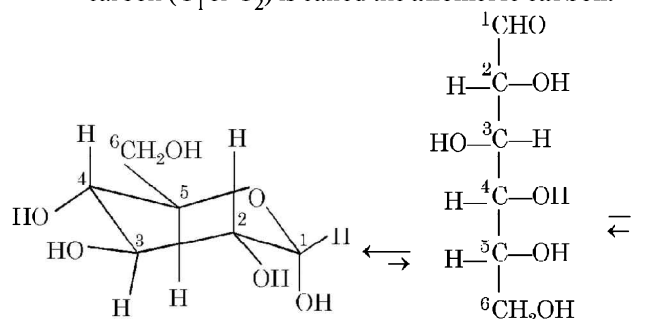

$\alpha$ -D-(+)-Glucopyranose  
m.p.  $146^\circ C$ ;  $[\alpha]_D = +112.2^\circ$   
(36% at equilibrium)

Open chain form  
of D-(+)-glucose  
(negligible % at equilibrium)

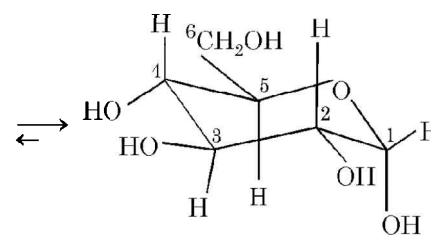

$\beta$ -D-(+)-Glucopyranose  
m.p.  $150^\circ C$ ;  $[\alpha]_D = +18.7^\circ$   
(61% at equilibrium)

m)

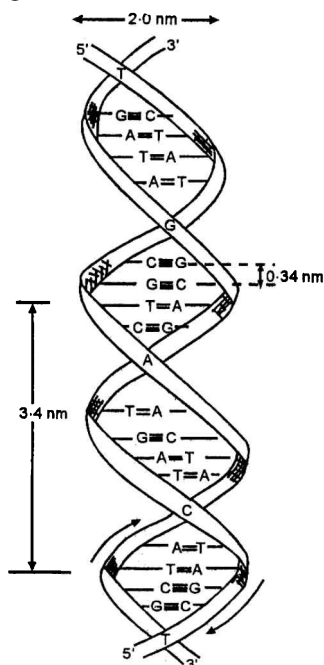

16. (a) The pyrimidine bases present in DNA are cytosine and thymine.
17. (b) The secondary structure of a protein refers to the shape in which a long peptide chain can exist. There are two different conformations of the peptide linkage present in protein, these are  $\alpha$ -helix and  $\beta$ -conformation. The  $\alpha$ -helix always has a right handed arrangement. In  $\beta$ -conformation all peptide chains are stretched out to nearly maximum extension and then laid side by side and held together by intermolecular hydrogen bonds. The structure resembles the pleated folds of drapery and therefore is known as  $\beta$ -pleated sheet.
18. (c) **NOTE** : Ozone layer acts as a shield and does not allow ultraviolet radiation from sun to reach earth. It does not prevent infra-red radiation from sun to reach earth. Thus option (c) is wrong statement and so it is the correct answer.
19. (d) Bakelite is formed by the reaction of formaldehyde (HCHO) and phenol so the correct answer is (d).

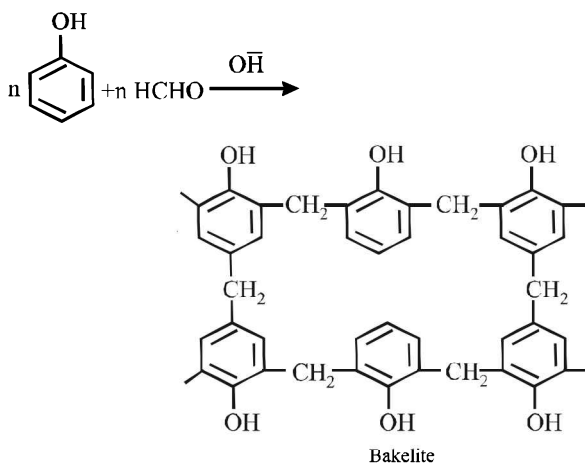

20. (c) Since  $\alpha$ -D-(+)-glucose and  $\beta$ -D-(+)-glucose differ in configuration at C-1

atom so they are anomers.

**NOTE** : Anomers are those diastereomers that differ in configuration at C-1 atom. i.e., (c) in the correct answer.

21. (c) The cross linked polymers will be formed by  $\text{RSiCl}_3$

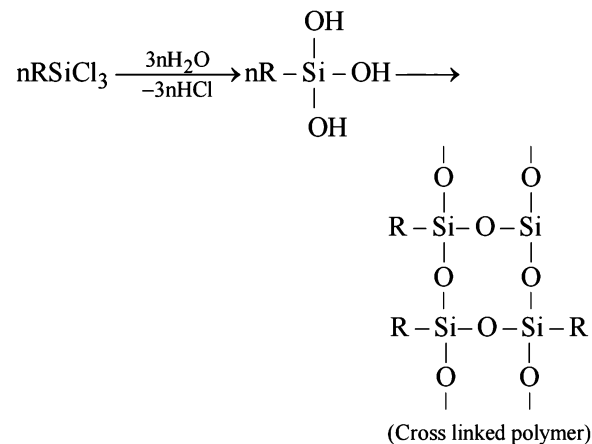

The correct choice is (c)

22. (b) Buna-N is a copolymer of butadiene ( $\text{CH}_2=\text{CH}-\text{CH}=\text{CH}_2$ ) and acrylonitrile ( $\text{CH}_2=\text{CHCN}$ ).
23. (c) **NOTE** : Glucose is considered as a typical carbohydrate which contains  $-\text{CHO}$  and  $-\text{OH}$  group.
24. (a) Biuret test produces violet colour on addition of dilute  $\text{CaSO}_4$  to alkaline solution of a compound containing peptide linkage.

Polypeptides, proteins and urea have  $-\text{C}-\text{NH}-$   
 $\parallel$   
 $\text{O}$

(peptide) linkage while carbohydrates have glycosidic linkages. So, test of carbohydrates should be different from that of other three.

25. (b) Nylon 6-6 has amide linkage capable of forming hydrogen bonding.

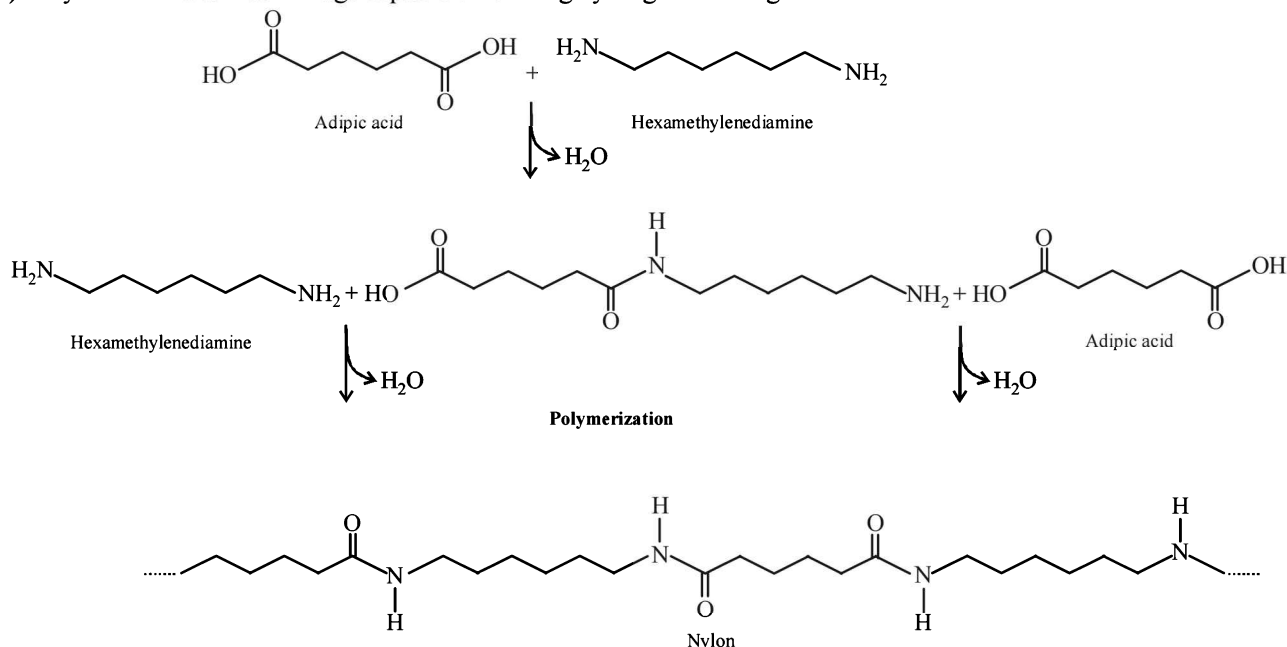

## Carbohydrates, Amino Acids, Polymers &amp; Miscellaneous Match the Following

26. (b) RNA has D (-) - Ribose and the DNA has 2-Deoxy D (-) - ribose as the carbohydrate unit.

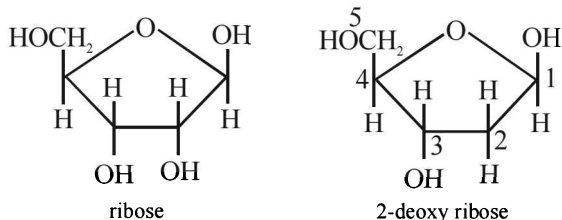

From the structures it is clear that 2<sup>nd</sup> carbon in DNA do not have OH group.

27. (b) **Molisch's Test** : This is a general test for carbohydrates. One or two drops of alcoholic solution of  $\alpha$ -naphthol is added to 2 ml glucose solution. 1 ml of conc.  $H_2SO_4$  solution is added carefully along the sides of the test-tube. The formation of a violet ring at the junction of two liquids confirms the presence of a carbohydrate or sugar.
28. (c) Lewis acids are the most common compounds used for initiation of cationic polymerisation. The more popular Lewis acids are  $SnCl_4$ ,  $AlCl_3$ ,  $BF_3$  and  $TiCl_4$ .
29. (c) With the exception of glycine all the 19 other common amino acids have a uniquely different functional group on the central tetrahedral alpha carbon.

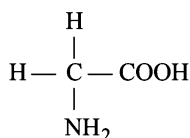

glycine

30. (a) Aspirin (Acetyl salicylic acid)

31. (a)  $6CO_2 + 12NADPH + 18ATP \rightarrow C_6H_{12}O_6 + 12NADP + 18ADP$

32. (a) Except Dacron all are additive polymers. Terephthalic acid condenses with ethylene glycol to give Dacron.



Terephthalic acid



Ethylene glycol

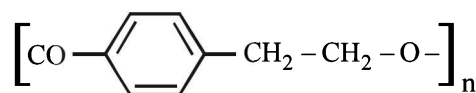

Dacron (Polyester)

33. (a) DNA contains ATGC bases  
So quinoline is not present in DNA.
34. (c) Water-soluble vitamins dissolve in water and are not stored by the body. The water soluble vitamins include the vitamin B-complex group and vitamin C.
35. (a) Phenelzine is an antidepressant, while others are antacids.
36. (d) Glyptal is used in the manufacture of paints and lacquers.
37. (a) The maximum limit of nitrate in drinking water is 50 ppm. Excess nitrate in drinking water can cause disease such as methemoglobinemia ('blue baby' syndrome).
38. (d) Sodium lauryl sulphate ( $C_{11}H_{23}CH_2OSO_3^-Na^+$ ) is an anionic detergent. Glycerol oleate is a glycerol ester of oleic acid. Sodium stearate ( $C_{17}H_{35}COO^-Na^+$ ) is a soap. Cetyltrimethyl ammonium bromide
- $$\left[ CH_3(CH_2)_{15}N^+(CH_3)_3 \right] Br^- \text{ is a cationic detergent.}$$
39. (b) High density polythene is used in the manufacture of housewares like buckets, dustbins, bottles, pipes etc. Low density polythene is used for insulating electric wires and in the manufacture of flexible pipes, toys, coats, bottles etc.

**MISCELLANEOUS — MATCH THE FOLLOWING FOR IIT-JEE**

- I** (i) Free radical substitution (ii) Thermite process  
 (iii) Nucleophilic addition (iv) Cyanamide process;  
 (v) Nucleophilic substitution (vi) Baeyer's process  
 (vii) Homologous pair  
 (viii) Electrophilic substitution (ix) Ostwald's process  
 (x) Homolytic addition.
- II** A. (i) (g) (ii) (d) (iii) (e) (iv) (a)  
 (v) (f) (vi) (b) (vii) (c)  
 B. (viii) (o) (ix) (m) (x) (k) (xi) (l)  
 (xii) (n) (xiii) (j)  
 C. (xiv) (s) (xv) (r) (xvi) (q) (xvii) (p)  
 D. (xviii) (w) (xix) (v) (xx) (u) (xxi) (t).
- III** A. (i) (b) (ii) (c) (iii) (d) (iv) (a)  
 B. (i) (c) (ii) (a) (iii) (d) (iv) (b)  
 C. (i) (b) (ii) (c) (iii) (d) (iv) (a)  
 D. (i) (d) (ii) (b) (iii) (a) (iv) (c).
- IV** (i)-(f)-6; (ii)-(c)-2; (iii)-(d)-4; (iv)-(b)-1; (v)-(a)-5; (vi)-(e)-3.
- V** A. (i) (a) (ii) (c) (iii) (b) (iv) (e) (v) (d)  
 B. (vi) (h) (vii) (j) (viii) (i) (ix) (g) (x) (f)  
 C. (xi) (n) (xii) (l) (xiii) (o) (xiv) (m) (xv) (k)  
 D. (xvi) (t) (xvii) (r) (xviii) (s) (xix) (p) (xx) (q)
- VI** (i) (g) (ii) (h) (iii) (f) (iv) (c)  
 (v) (e) (vi) (d) (vii) (b) (viii) (a)
- VII** (i) Invar/Fe, Ni/watch spring; Nichrome/Co, Ni/heating element; Rydberg/cm<sup>-1</sup>/109677; Stainless steel/Fe, Cr, Ni, C/cutlery; Boltzmann/kJ deg<sup>-1</sup>/1.3805 × 10<sup>-26</sup>  
 (ii) Friedel-Craft/Lewis acid/anhydrous AlCl<sub>3</sub>; Fermentation/yeast/ethanol; Dehydrogenation/alcoholic alkali/alkene; Sandmeyer/cuprous chloride/chlorobenzene; Saponification/oil/soap.
- VIII** A-(c)-(ii); B-(e)-(iii); C-(a)-(iv); D-(b)-(v); E-(d)-(i).
- IX** (A) – (p), (s) (CH<sub>3</sub>)<sub>2</sub>SiCl<sub>2</sub> + 2H<sub>2</sub>O
- $$\xrightarrow{-2\text{HCl}} (\text{CH}_3)_2\text{Si}(\text{OH})_2$$
- $$\xrightarrow{\text{Polymerisation}} [(\text{CH}_3)_2\text{Si}-\text{O}]_n$$
- (B) – (p), (q), (r), (t) XeF<sub>4</sub> + H<sub>2</sub>O →  
 Xe + XeO<sub>3</sub> + H<sub>2</sub>F<sub>2</sub> + O<sub>2</sub>  
 SiO<sub>2</sub> + 4HF → SiF<sub>4</sub> + 2H<sub>2</sub>O  
 glass  
 SiF<sub>4</sub> + 2HF → H<sub>2</sub>[SiF<sub>6</sub>]  
 Soluble hexathorosilicic(IV)  
 acid
- (C) – (p), (q) Cl<sub>2</sub> + H<sub>2</sub>O → HCl + HOCl  
 (D) – (p), (q) VCl<sub>5</sub> + 7H<sub>2</sub>O → [V(H<sub>2</sub>O)<sub>6</sub>]<sup>3+</sup>  
 + 3Cl<sup>-</sup> + HCl + HOCl

**Section-A : JEE Advanced/ IIT-JEE**

- A** 1.  $\text{Fe}^{3+}$       2.  $\text{CrO}_2\text{Cl}_2$
- B** 1. T      2. T
- C** 1. (d)      2. (a)      3. (c)      4. (d)      5. (d)      6. (c)      7. (a)  
8. (c)      9. (b)      10. (b)      11. (b)      12. (a)      13. (d)
- D** 1. (a, b)      2. (a, b, d)      3. (b, c)      4. (c, d)      5. (a or a, c)
- E** 3.  $\text{CO}_2, \text{H}_2\text{O}, \text{NaHCO}_3, \text{Na}_2\text{CO}_3, \text{BaCO}_3$       4.  $\text{FeCl}_2, \text{NH}_4\text{Cl}$   
A B X Y Z
5.  $\text{FeSO}_4 \cdot 7\text{H}_2\text{O}, \text{FeSO}_4, \text{FeSO}_4 \cdot \text{NO}, \text{Fe}_2\text{O}_3, \text{SO}_2, \text{SO}_3$       6.  $\text{CO}_2, \text{H}_2\text{O}, \text{KHCO}_3, \text{K}_2\text{CO}_3, \text{BaCO}_3$   
A B C D E F      A B X Y Z
7.  $\text{NH}_4^+, \text{Fe}^{2+}, \text{SO}_4^{2-}, \text{Cl}^-$       8.  $\text{NH}_4^+, \text{Fe}^{2+}, \text{SO}_4^{2-}, \text{FeSO}_4(\text{NH}_4)_2\text{SO}_4 \cdot 6\text{H}_2\text{O}$
9.  $(\text{NH}_4)_2\text{Cr}_2\text{O}_7, \text{Cr}_2\text{O}_3, \text{N}_2, \text{Mg}_3\text{N}_2, \text{NH}_3$       10.  $\text{KO}_2, \text{K}_2\text{SO}_4, \text{Al}_2(\text{SO}_4)_3, 24\text{H}_2\text{O}$   
A B C D E      A B C D
11.  $\text{Pb}_3\text{O}_4, \text{PbO}_2, \text{PbI}_2$       12.  $\text{NH}_3, \text{CaCO}_3$   
A B C      A B
15. (i)  $\text{Na}_2\text{O}_2$ , (ii) turns red litmus blue
17.  $\text{Cu}^{2+}$       19.  $\text{ZnS}, \text{H}_2\text{S}, \text{ZnSO}_4, \text{S}, \text{SO}_2$   
A B C D E
20.  $\text{CrO}_2\text{Cl}_2, \text{Na}_2\text{CrO}_4, \text{PbCrO}_4$ , iodide of Millon's base,  $\text{NH}_4\text{Cl}$   
A B C D
21.  $\text{HgI}_2, \text{KI}, \text{HgS}, \text{Hg}$   
A B C D
- G** 1. (d)      2. (c)      3. (b)      4. (a)      5. (d)      6. (b)      7. (d)
- H** 1. (b)      2. (b)
- I** 1. 7

**Section-B : JEE Main/ AIEEE**

1. (c)      2. (b)      3. (a)      4. (a)      5. (b)

**Section-A JEE Advanced/ IIT-JEE****A. Fill in the Blanks**

- $\text{Fe}^{3+}$ ; Without oxidation with  $\text{HNO}_3$ , the  $\text{Fe}^{2+}$  ions present would not be converted into  $\text{Fe}^{3+}$ . So  $\text{Fe}(\text{OH})_2$  will not be precipitated as its solubility product is higher than that of  $\text{Fe}(\text{OH})_3$  and as  $\text{NH}_4\text{Cl}$  suppresses the ionisation of  $\text{NH}_4\text{OH}$ , this solubility product is not reached.
- Chromyl chloride ( $\text{CrO}_2\text{Cl}_2$ ).

**B. True/ False**

- True** : Function of ammonium chloride is to suppress the ionisation of  $\text{NH}_4\text{OH}$  and thus check the precipitation of  $\text{Mg}(\text{OH})_2$  because the solubility product of  $\text{Mg}(\text{OH})_2$  is high. This is used in salt analysis when 3rd group radicals are precipitated. The group reagent are  $\text{NH}_4\text{OH}$  in presence of  $\text{NH}_4\text{Cl}$ .

- True** :  $K_{sp}$  of  $\text{CuS}$  is less than  $K_{sp}$  of  $\text{ZnS}$ . On passing  $\text{H}_2\text{S}$  in acidic medium, the dissociation of  $\text{H}_2\text{S}$  is suppressed due to common ion effect and it provides  $[\text{S}^{2-}]$  which is just sufficient to cross over  $K_{sp}$  of  $\text{CuS}$  and not  $K_{sp}$  of  $\text{ZnS}$ . Thus only  $\text{CuS}$  gets precipitated.

**C. MCQs with ONE Correct Answer**

- (d)  $\text{Sn}^{2+}$  can be precipitated by  $\text{H}_2\text{S}$  but not by  $\text{HCl}$ .
- (a) **NOTE** : The ions of group II of salt analysis are precipitated by  $\text{HCl}$  and  $\text{H}_2\text{S}$  whereas members of group IV are precipitated by  $\text{H}_2\text{S}$  in alkaline medium.  
 $\therefore \text{Bi}^{3+}$  and  $\text{Sn}^{4+}$  both belong to group II  
 $\therefore$  They will be precipitated by  $\text{HCl}$  in presence of  $\text{H}_2\text{S}$ . Both  $\text{Bi}^{3+}$  and  $\text{Sn}^{4+}$  belong to group II of qualitative inorganic analysis and will get precipitated by  $\text{H}_2\text{S}$ .



## E. Subjective Problems

- $\text{HNO}_3$  is strong oxidising agent and it oxidises  $\text{H}_2\text{S}$  to S. So  $\text{HNO}_3$  cannot be used to precipitate second group elements.
- (i) (A) is  $\text{FeSO}_4 \cdot 7\text{H}_2\text{O}$  because it is light green crystalline solid. Which dissolves in water containing  $\text{H}_2\text{SO}_4$   
(ii) On strong heating  $\text{FeSO}_4$  both  $\text{SO}_2$  (B) and  $\text{SO}_3$  (C) are evolved. The colour of  $\text{KMnO}_4$  disappears due to the formation of  $\text{MnSO}_4$ .  
(iii)  $\text{SO}_2$  being a reducing agent turns a dichromate solution green and forms  $\text{H}_2\text{SO}_4$  in the solution.  $\text{SO}_3$  dissolves in water to give  $\text{H}_2\text{SO}_4$ . Therefore, white ppt of  $\text{BaSO}_4$  is formed with a solution of  $\text{Ba}(\text{NO}_3)_2$   
(iv) The brown residue left behind (D) is  $\text{Fe}_2\text{O}_3$  which is reduced to Fe on heating in charcoal cavity. Fe is magnetic substance.
- Representing the given facts in the form of equation.

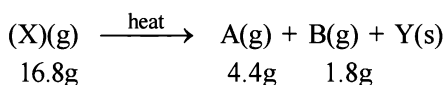

The above equation leads to the following facts :

- Since the gas A turned lime water milky, it must be  $\text{CO}_2$ .
- NOTE :** The compound Y gives alkaline solution in water which when treated with  $\text{BaCl}_2$  forms a white precipitate of Z. Since the compound Z when treated with acid gives effervescence of  $\text{CO}_2$ , Z and hence Y must be metal carbonate,  $\text{CO}_3^{2-}$ . Hence Y may be written as metal carbonate  $\text{MCO}_3$  or  $\text{M}_2\text{CO}_3$ .
- When X is heated, it yields a carbonate (Y) along with the evolution of  $\text{CO}_2$  (A) and another gas (B), it must be a bicarbonate.
- The above facts point out that B may be water vapour. Thus the above reaction can be written as below.

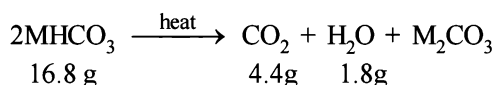

Calculation of molecular weight of  $\text{MHCO}_3$   
4.4 g of  $\text{CO}_2$  is given by 16.8 g of  $\text{MHCO}_3$

$$\therefore 44\text{g of CO}_2 \text{ is given by } = \frac{16.8}{4.4} \times 44 = 168\text{g}$$

Since two molecules of  $\text{MHCO}_3$  are taking part in the reaction, the molecular weight of

$$\text{MHCO}_3(\text{X}) = \frac{168}{2} = 84$$

Calculation of atomic weight of metal M

$$\text{MHCO}_3 = 84; \text{M} + 1 + 12 + 48 = 84$$

$$\text{M} + 61 = 84; \text{M} = 84 - 61 = 23$$

Thus the metal must be Na and hence the given salt X is  $\text{NaHCO}_3$ . The above facts coincide with the given thermal decomposition.

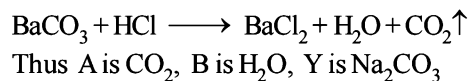
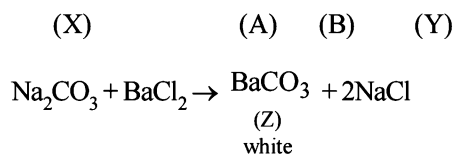
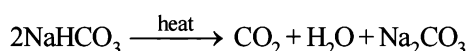

- (A) Test (i) of the problem indicates that the mixture contains  $\text{Cl}^-$  ion which is liberated as  $\text{Cl}_2$  (yellowish green gas) when heated with  $\text{MnO}_2$  and conc.  $\text{H}_2\text{SO}_4$ .  
(B) Test (ii) indicates the presence of  $\text{NH}_4^+$  ion in the mixture which gives ammonia when heated with  $\text{NaOH}$  solution. Since ammonia is basic in nature, it turns red litmus blue. Presence of  $\text{NH}_4^+$  in the mixture is further confirmed by the given test (iv) according to which the gas ( $\text{NH}_3$ ) gives brown precipitate with Nessler's reagent (alkaline solution of  $\text{K}_2[\text{HgI}_4]$ ).
- (C) Test (iii) indicates  $\text{Fe}^{2+}$  ion in the mixture which gives blue precipitate with potassium ferricyanide (note that potassium ferricyanide gives brown ppt. with  $\text{Fe}^{3+}$  ions).
- (D) Red colouration with ammonium thiocyanate indicates that the mixture also contains  $\text{Fe}^{3+}$  ions which are believed to be formed by the oxidation of  $\text{Fe}^{2+}$  ions by air.

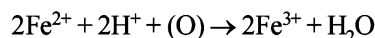

Thus the mixture contains  **$\text{FeCl}_2$  and  $\text{NH}_4\text{Cl}$** .

Ionic reactions :

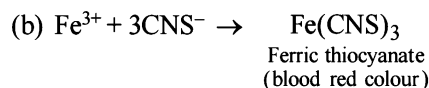
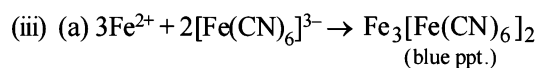
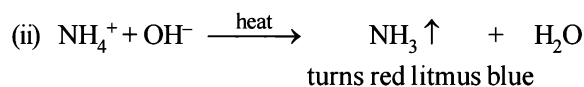
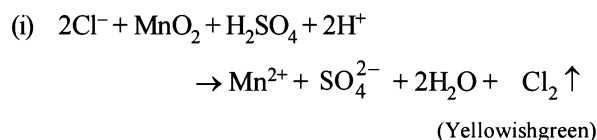

- (i) (A) on heating loses water of crystallization and thus it is a hydrated salt.  
(ii) Anhydrous salt (B) on heating gives two gases and brown residue and so (B) is  $\text{FeSO}_4$ . Thus (A) is  $\text{FeSO}_4 \cdot 7\text{H}_2\text{O}$   
$$\begin{array}{ccc} \text{FeSO}_4 \cdot 7\text{H}_2\text{O} & \xrightarrow{\Delta} & \text{FeSO}_4 + 7\text{H}_2\text{O} \\ \text{(A)} & & \text{(B)} \end{array}$$
  
$$\begin{array}{ccccccc} 2\text{FeSO}_4 & \xrightarrow{\Delta} & \text{Fe}_2\text{O}_3 & + & \text{SO}_2 \uparrow & + & \text{SO}_3 \uparrow (\text{s}) \\ \text{(B)} & & \text{(D)} & & \text{(E)} & & \text{(F)} \\ & & \text{Brown} & & & & \end{array}$$
- (iii) (B) is soluble in water and reacts with NO to give brown compound.



Brown ring (C)

- (iv) Gaseous mixture decolorizes acidified  $\text{KMnO}_4$ .  
 $5\text{SO}_2 + 2\text{KMnO}_4 + 2\text{H}_2\text{O} \rightarrow \text{K}_2\text{SO}_4 + 2\text{MnSO}_4 + 2\text{H}_2\text{SO}_4$
- (v) Gaseous mixture on passing through  $\text{BaCl}_2$ , gives white ppt. of  $\text{BaSO}_4$ .  
 $\text{SO}_3 + \text{H}_2\text{O} \rightarrow \text{H}_2\text{SO}_4$   
 $\text{BaCl}_2 + \text{H}_2\text{SO}_4 \rightarrow \text{BaSO}_4 + 2\text{HCl}$   
 white ppt.

6. Representing the given facts in the form of equation, we get

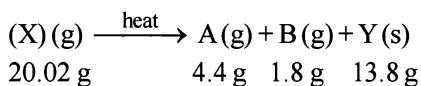

The above equation leads to the following facts :

- (i) Since the gas A turned lime water milky, it must be  $\text{CO}_2$ .
- (ii) **NOTE :** The compound Y is alkaline to litmus and when treated with  $\text{BaCl}_2$  forms a white precipitate of Z. Since the compound Z when treated with acid gives effervescence of  $\text{CO}_2$ , Z and hence Y must contain carbonate,  $\text{CO}_3^{2-}$ . Hence Y may be written as metal carbonate  $\text{MCO}_3$  or  $\text{M}_2\text{CO}_3$ .
- (iii) When X is heated, it yields a carbonate (Y) along with the evolution of  $\text{CO}_2$  (A) and a neutral gas (B), it must be a bicarbonate.
- (iv) B changes anhydrous  $\text{CuSO}_4$  blue, which point out that B is water.

Thus the above reaction can be written as below :

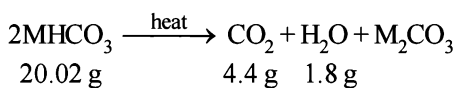

Calculation of molecular weight of  $\text{MHCO}_3$

4.4 g of  $\text{CO}_2$  is given by 20.02 g of  $\text{MHCO}_3$

$$44 \text{ g of } \text{CO}_2 \text{ is given by} = \frac{20.02}{4.4} \times 44 = 200.2 \text{ g}$$

Since two molecules of  $\text{MHCO}_3$  are taking part in the reaction, the molecular weight of

$$\text{MHCO}_3(\text{X}) = \frac{200.2}{2} = 100$$

Calculation of atomic weight of Metal M

$$\text{MHCO}_3 = 100; \text{M} + 1 + 12 + 48 = 100$$

$$\text{M} + 61 = 100; \text{M} = 100 - 61 = 39$$

Thus the metal must be K and hence the given salt X is  $\text{KHCO}_3$ . The above facts coincide with the given thermal decomposition.

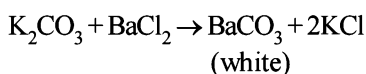
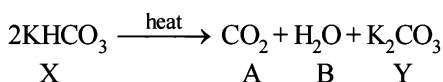

Hence, we have

$\text{X} = \text{KHCO}_3$ ,  $\text{Y} = \text{K}_2\text{CO}_3$ ,  $\text{Z} = \text{BaCO}_3$ ,  $\text{A} = \text{CO}_2$ ,  $\text{B} = \text{H}_2\text{O}$

7. Let us summarise the given facts of the question.

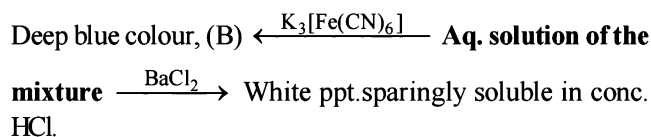
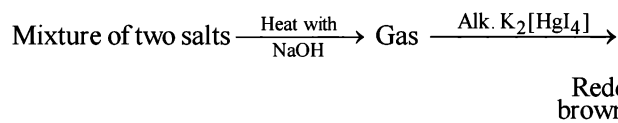
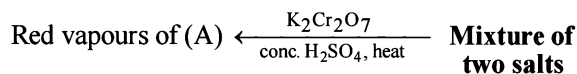

The given reactions lead to the following conclusions.

- (i) Formation of reddish brown precipitate on treatment with alk.  $\text{K}_2[\text{HgI}_4]$  indicates the evolution of  $\text{NH}_3$  gas and hence the presence of  $\text{NH}_4^+$  in the mixture of salts.
- (ii) Heating of mixture with  $\text{K}_2\text{Cr}_2\text{O}_7$  and conc.  $\text{H}_2\text{SO}_4$  to give red vapours (of chromyl chloride) indicates the presence of  $\text{Cl}^-$  ion in the mixture.
- (iii) Reaction of aqueous solution of the mixture with barium chloride solution to give white ppt. (of  $\text{BaSO}_4$ ) sparingly soluble in conc. HCl indicates the presence of  $\text{SO}_4^{2-}$  ions in the mixture.
- (iv) **NOTE :** Reaction of aqueous solution of the mixture with potassium ferricyanide solution to give deep blue colour indicates the presence of  $\text{Fe}^{2+}$  ions in the mixture.

Hence the mixture contains following four ions :

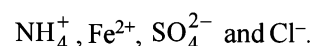

Equations for the formation of A and B.

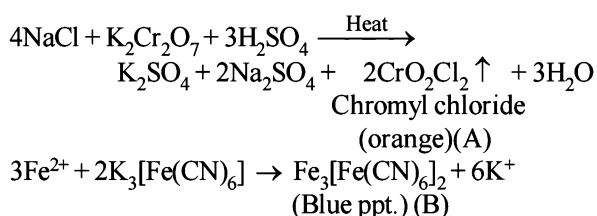

8. 'Compound gives brown ppt. with alkaline  $\text{K}_2[\text{HgI}_4]$  and so contain  $\text{NH}_4^+$  ions.'

'Compound gives blue colour with  $\text{K}_3[\text{Fe}(\text{CN})_6]$  and so contains  $\text{Fe}^{2+}$  ions.'

'Solution of compound in HCl gives white ppt. with  $\text{BaCl}_2$  and so it contains  $\text{SO}_4^{2-}$  ions.'

'Bluish green compound with  $\text{NH}_4^+$ ,  $\text{Fe}^{2+}$  and  $\text{SO}_4^{2-}$  suggests that it is Mohr's salt i.e.'

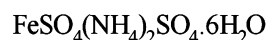

Reactions :

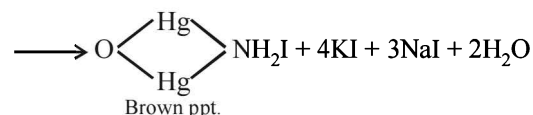
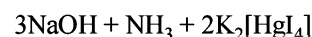







20. Let us summarise the given facts.

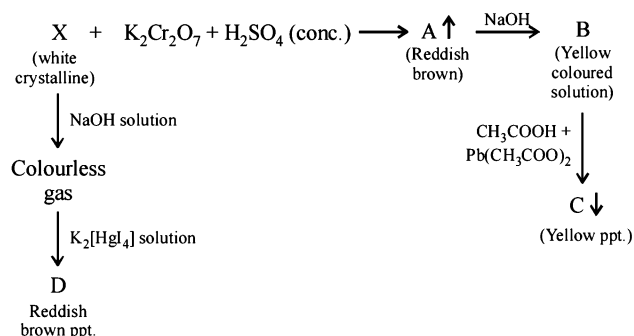

**NOTE :** Reaction of compound X with NaOH solution and subsequent treatments indicate that X has  $\text{NH}_4^+$  radical. On the other hand, reaction of X with  $\text{K}_2\text{Cr}_2\text{O}_7$  solution, conc.  $\text{H}_2\text{SO}_4$  and subsequent treatments indicate that A has  $\text{Cl}^-$  radical. Thus compound X is  $\text{NH}_4\text{Cl}$  which explains all the above reactions.

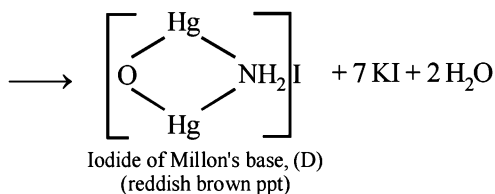
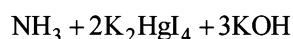
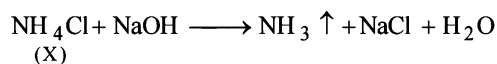
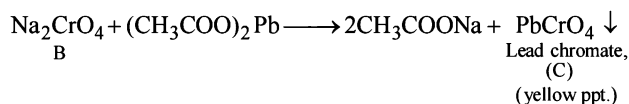
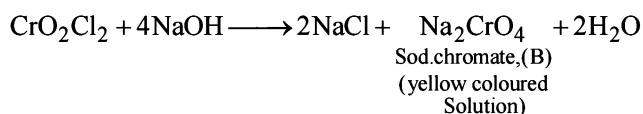
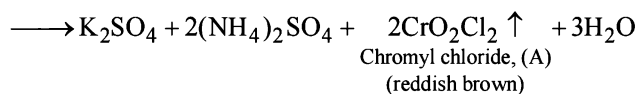
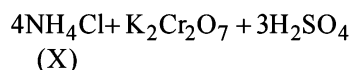

21. [A =  $\text{HgI}_2$  (yellow), B = KI (colourless)]

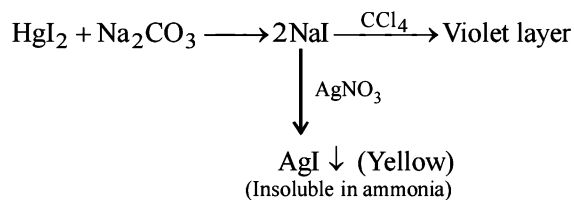
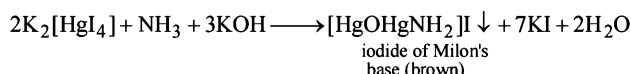
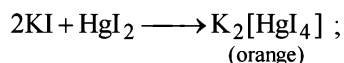
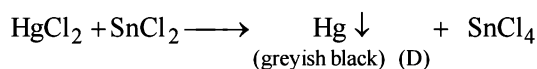
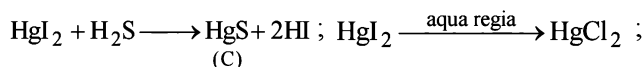

### G. Comprehension Based Questions

For 1-3

Reaction of Y indicates that it is  $\text{Fe}^{3+}$  salt.

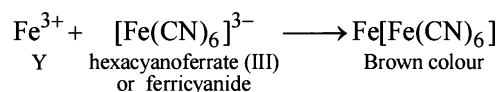
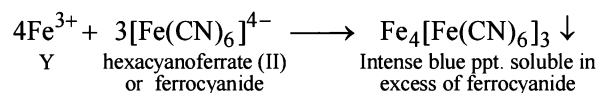

**NOTE :** since the product formed (methylene blue) has sulphur in its structure, it should be supplied by the compound X which is thus  $\text{Na}_2\text{S}$ .

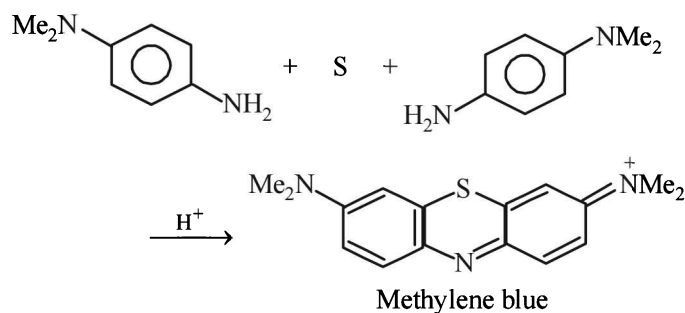
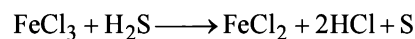
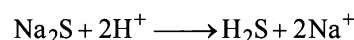

Thus

- (d)
- (c)
- (b)
- (a) Lead salts give white precipitate of  $\text{PbCl}_2$  with dil. HCl which is soluble in hot water.  

$$\text{Pb}^{2+} + 2\text{Cl}^- \longrightarrow \text{PbCl}_2 \text{ (White ppt) soluble in hot water}$$
- (d) The filtrate on treatment with ammoniacal  $\text{H}_2\text{S}$  gives a precipitate which dissolves in aqueous NaOH containing  $\text{H}_2\text{O}_2$  giving a coloured solution. It contains  $\text{Cr}^{3+}$  ion.

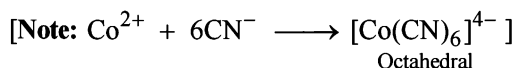
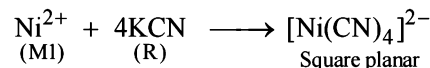
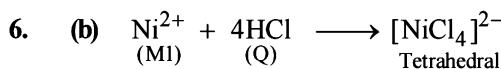
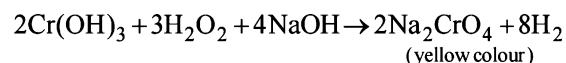
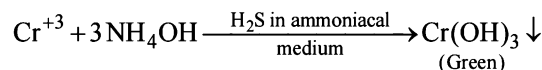

7. (d)

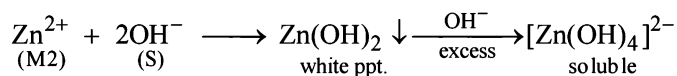
**H. Assertion & Reason Type Questions**

1. (d)  $\text{Cd}^{2+}$  is a 2nd group radical and  $\text{Ni}^{2+}$  is a 4th group radical. So solubility product of NiS has to be more than CdS. Further  $\text{Cd}^{2+}$  gives yellow colour of CdS with  $\text{H}_2\text{S}$ , but  $\text{Ni}^{2+}$  gives black colour of NiS with  $\text{H}_2\text{S}$ .

So both assertion and statement are wrong. (d) is correct choice.

2. (b) Sulphate is estimated as  $\text{BaSO}_4$  because of its insolubility in water.  $\text{BaSO}_4$  forms a white ppt. Therefore reason is correct but do not explain the assertion.

**I. Integer Value Correct Type**

1. (7) All except MnS (buff coloured) and  $\text{SnS}_2$  (yellow) are black in colour.

**Section-B JEE Main/ AIEEE**

1. (c) When  $\text{H}_2\text{S}$  is passed through  $\text{Hg}_2\text{S}$  we get a mixture of mercurous sulphide and mercury ( $\text{Hg}_2\text{S} + \text{Hg}$ ).
2. (b) When we add  $\text{NH}_4\text{Cl}$ , it suppresses the ionisation of  $\text{NH}_4\text{OH}$  and prevents the precipitation of higher group hydroxide in gp(III).

**NOTE :** Further ferric chloride and chromium chloride form different colour precipitates with  $\text{NH}_4\text{OH}$ .

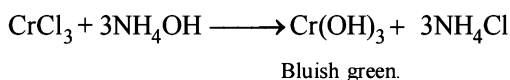
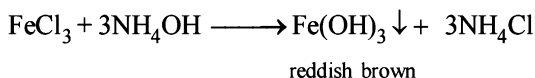

3. (a) Between AgCl and AgI, AgI is less soluble, hence ammonia can dissolve ppt. of AgCl only due to formation of complex as given below:

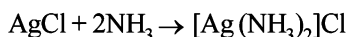

4. (a) Prussian blue  $\text{Fe}_4[\text{Fe}(\text{CN})_6]_3$  is formed in lassaigne test for nitrogen.

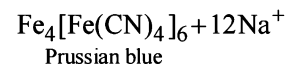
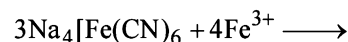

5. (b) The complex  $[\text{CoCl}(\text{NH}_3)_5]^+$  decomposes under acidic medium, so

