

Particle Kinematics

Kinematics

In kinematics we study how a body moves without knowing why it moves. All particles of a rigid body in translation motion move in identical fashion hence any of the particles of a rigid body in translation motion can be used to represent translation motion of the body. This is why, while analyzing its translation motion, a rigid body is considered a particle and kinematics of translation motion as particle kinematics.

Particle kinematics deals with nature of motion i.e. how fast and on what path an object moves and relates the position, velocity, acceleration, and time without any reference to mass, force and energy. In other words, it is study of geometry of motion.

Types of Translation Motion

A body in translation motion can move on either a straight–line path or curvilinear path.

Rectilinear Motion

Translation motion on straight–line path is known as rectilinear translation. It is also known as one–dimensional motion. A car running on a straight road, train running on a straight track and a ball thrown vertically upwards or dropped from a height etc are very common examples of rectilinear translation.

a curvilinear trajectory in Edujournalaverticalplane;astnetiedtoastring when whirled describes a circular path and an insect crawling on the floor or on wall are examples of two–dimensional motion.

Curvilinear Motion

Translation motion of a body on curvilinear path is known as curvilinear translation. If the trajectory is in a plane, the motion is known as two–dimensional motion. A ball thrown at some angle with the horizontal describes

If path is not in a plane and requires a region of space or volume, the motion is known as three–dimensional motion or motion in space. An insect flying randomly in a room, motion of a football in soccer game over considerable duration of time etc are common examples of three–dimensional motion.

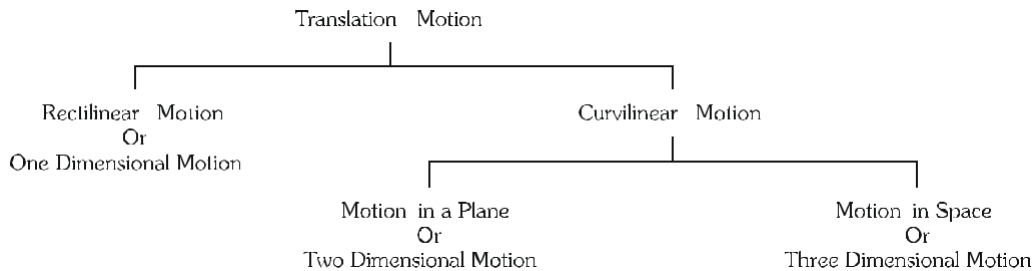

Reference Frame

Motion of a body can only be observed if it changes its position with respect to some other body. Therefore, for a motion to be observed there must be a body, which is changing its position with respect to other body and a person who is observing motion. The person observing motion is known as observer. The observer for the purpose of investigation must have its own clock to measure time and a point in the space attached with the other body as origin and a set of coordinate axes. These two things the time measured by the clock and the coordinate system are collectively known as reference frame.

In this way, motion of the moving body is expressed in terms of its position coordinates changing with time.

Position Vector, Velocity and Acceleration Vector

For analyzing translation motion, we assume the moving body as a particle and represent it as mathematical point. Consider a particle P moving on a curvilinear path.

Position – Vector

It describes position of a particle relative to other particle and is a vector from the later towards the first. To study motion of a particle we have to assume a reference frame fixed with some other body. The vector drawn from the origin of the coordinate system representing the reference frame to the location of the particle P is known as position vector of the particle P.

Consider a particle P moving in space traces a path shown in the figure. Its position continuously changes with time and so does the position vector. At an instant of time, its position vector \vec{r} is shown in the following figure.

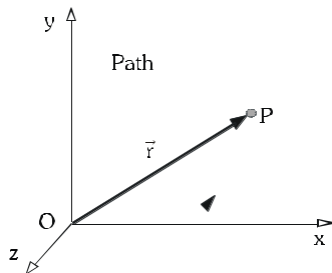

Position Vector

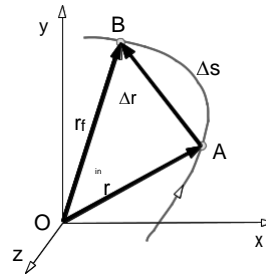

Displacement Vector & Distance Traveled

Displacement and distance traveled

Displacement is measure of change in place i.e. position of particle. It is defined by a vector from the initial position to the final position. Let the particle moves from point A to B on the curvilinear path. The vector

$\vec{AB} = \Delta \vec{r}$ is displacement.

Distance traveled is length of the path traversed. We can say it “path length”. Here in the figure length of the curve Δs from A to B is the distance traveled.

Distance traveled between two places is greater than the magnitude of displacement vector wherever particle changes its direction during its motion. In unidirectional motion, both of them are equal.

Average Velocity and Average Speed

Average velocity of a particle in a time interval is that constant velocity with which particle would have covered the same displacement in the same time interval as it covers in its actual motion. It is defined as the ratio of displacement to the concerned time interval.

If the particle moves from point A to point B in time interval t_i to t_f , the average velocity v_{av} in this time interval is given by the following equation.

$$v_{av} = \frac{\Delta \vec{r}}{\Delta t} = \frac{\vec{r}_f - \vec{r}_i}{t_f - t_i}$$

Similar to average velocity, average speed in a time interval is that constant speed with which particle would travel the same distance on the same path in the same time interval as it travels in its actual motion. It is defined as the ratio of distance traveled to the concerned time interval.

If in moving from point A to B, the particle travels path length i.e. distance Δs in time interval t_i to t_f , its average speed c_{av} is given by the following equation.

$$c_{av} = \frac{\Delta s}{\Delta t} = \frac{\text{Path Length}}{t_f - t_i}$$

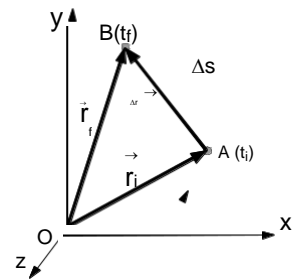

Average speed in a time interval is greater than the magnitude of average velocity vector wherever particle changes its direction during its motion. In unidirectional motion, both of them are equal.

Instantaneous Velocity and speed

If we assume the time interval Δt to be infinitesimally small i.e. $\Delta t \rightarrow 0$, the point B approaches A making the chord AB to coincide with the tangent at A. Now we can express the instantaneous velocity v by the following equations.

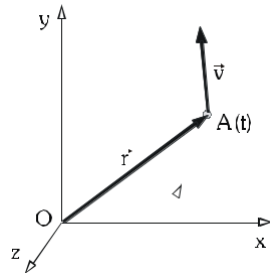

$$v = \lim_{\Delta t \rightarrow 0} \frac{\Delta r}{\Delta t} = \frac{dr}{dt}$$

The instantaneous velocity equals to the rate of change in its position vector r with time. Its direction is along the tangent to the path. Instantaneous speed is defined as the time rate of distance traveled.

Edujournalv

$$c = \lim_{\Delta t \rightarrow 0} \frac{\Delta s}{\Delta t} = \frac{ds}{dt}$$

You can easily conceive that when $\Delta t \rightarrow 0$, not only the chord AB but also the arc AB both approach to coincide with each other and with the tangent. Therefore $ds = |dr|$. Now we can say that speed equals to magnitude of instantaneous velocity.

Instantaneous speed tells us how fast a particle moves at an instant and instantaneous velocity tells us in what direction and with what speed a particle moves at an instant of time.

Acceleration

Instantaneous acceleration is a measure of how fast velocity of a body changes i.e. how fast direction of motion and speed change with time.

At an instant, it equals to the rate of change in velocity vector with time.

$$a = \frac{dv}{dt}$$

A vector quantity changes, when its magnitude or direction or both change. Accordingly, acceleration vector may have two components, one responsible to change only speed and the other responsible to change only direction of motion.

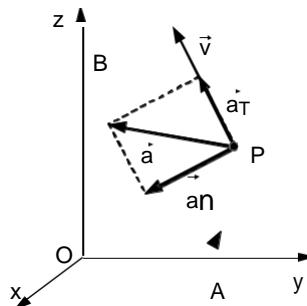

Component of acceleration responsible to change speed must be in the direction of motion. It is known as tangential component of acceleration a_T . The component responsible to change direction of motion must be perpendicular to the direction of motion. It is known as normal component of acceleration a_N . Acceleration vector a of a particle moving on a curvilinear path and its tangential and Normal components are shown in the figure.

Curvilinear Translation in Cartesian coordinate system:

Superposition of three rectilinear Motions

Consider a particle moving on a three dimensional curvilinear path AB. At an instant of time t it is at point $P(x, y, z)$ moving with velocity v and acceleration a . Its position vector is defined by equations

$$\vec{r} = x\hat{i} + y\hat{j} + z\hat{k}$$

Differentiating it with respect to time, we get velocity vector.

$$\vec{v} = \frac{d\vec{r}}{dt} = \frac{dx}{dt}\hat{i} + \frac{dy}{dt}\hat{j} + \frac{dz}{dt}\hat{k} = v_x\hat{i} + v_y\hat{j} + v_z\hat{k}$$

Here $v_x = dx/dt$, $v_y = dy/dt$ and $v_z = dz/dt$ are the components of velocity vectors in the x, y and z - directions respectively.

Now the acceleration can be obtained by differentiating velocity vector v with respect to time.

$$\vec{a} = \frac{d\vec{v}}{dt} = \frac{dv_x}{dt}\hat{i} + \frac{dv_y}{dt}\hat{j} + \frac{dv_z}{dt}\hat{k} = a_x\hat{i} + a_y\hat{j} + a_z\hat{k}$$

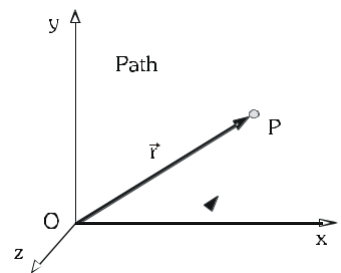

Acceleration vector can also be obtained by differentiating position vector twice with respect to time.

$$\vec{a} = \frac{d^2\vec{r}}{dt^2} = \frac{d^2x}{dt^2}\hat{i} + \frac{d^2y}{dt^2}\hat{j} + \frac{d^2z}{dt^2}\hat{k} = a_x\hat{i} + a_y\hat{j} + a_z\hat{k}$$

In the above two equations, $a_x = d^2x/dt^2 = dv_x/dt$, $a_y = d^2y/dt^2 = dv_y/dt$ and $a_z = d^2z/dt^2 = dv_z/dt$ are the components of acceleration vectors in the x, y and z - directions respectively.

In the above equations, we can analyze each of the components x, y and z of motion as three individual rectilinear motions each along one of the axes x, y and z .

Along the x -axis $v_x = \frac{dx}{dt}$ and $a_x = \frac{dv_x}{dt}$

Along the y -axis $v_y = \frac{dy}{dt}$ and $a_y = \frac{dv_y}{dt}$

Along the z -axis $v_z = \frac{dz}{dt}$ and $a_z = \frac{dv_z}{dt}$

A curvilinear motion can be analyzed as superposition of three simultaneous rectilinear motions each along one of the coordinate axes.

Example

Position vector \vec{r} of a particle varies with time t according to the law $\vec{r} = \left(\frac{1}{2}t^2\right)\hat{i} - \left(\frac{4}{3}t^{1.5}\right)\hat{j} + (2t)\hat{k}$, where r is in meters and t is in seconds.

- (a) Find suitable expression for its velocity and acceleration as function of time.
- (b) Find magnitude of its displacement and distance traveled in the time interval $t = 0$ to 4 s.



Solution

(a) Velocity v is defined as the first derivative of position vector with respect to time.

$$v = \frac{dr}{dt} = t\hat{i} - 2\sqrt{t}\hat{j} + 2\hat{k} \text{ m/s}$$

Acceleration a is defined as the first derivative of velocity vector with respect to time.

$$a = \frac{dv}{dt} = \hat{i} - \frac{1}{\sqrt{t}}\hat{j} \text{ m/s}^2$$

(b) Displacement Δr is defined as the change in place of position vector.

$$\Delta r = 8\hat{i} - \frac{32}{3}\hat{j} + 8\hat{k} \text{ m}$$

Magnitude of displacement $\Delta r = \sqrt{8^2 + \left(\frac{32}{3}\right)^2 + 8^2} = 15.55 \text{ m}$

Distance Δs is defined as the path length and can be calculated by integrating speed over the concerned time interval.

$$\Delta s = \int_0^4 v dt = \int_0^4 \sqrt{t^2 + 4t + 4} dt = \int_0^4 (t + 2) dt = 16 \text{ m}$$

Rectilinear Motion

Curvilinear motion can be conceived as superposition of three rectilinear motions each along one of the Cartesian axes. Therefore, we first study rectilinear motion in detail.

We can classify rectilinear motion problems in following categories according to given information.

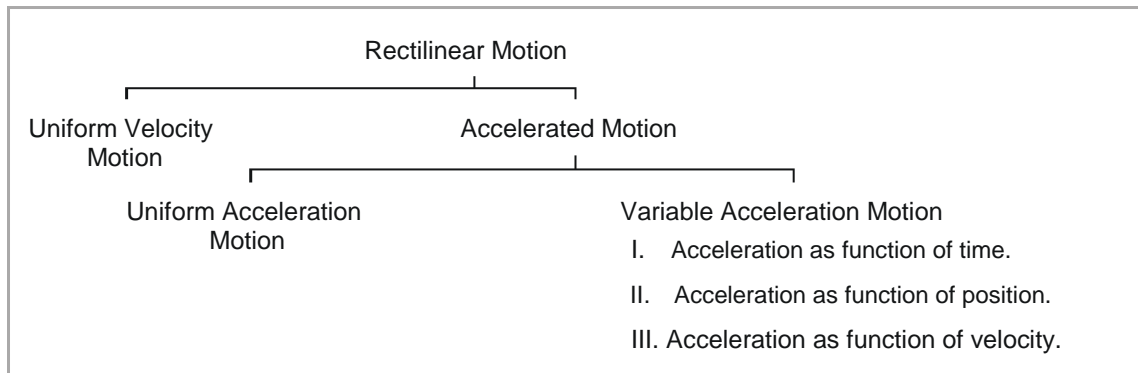

Uniform Velocity Motion

In uniform velocity motion, a body moves with constant speed on a straight-line path without change in direction.

If a body starting from position $x = x_0$ at the instant $t = 0$, moves with uniform velocity v in the positive x -direction, its equation of motion at any time t is $x = x_0 + vt$

Velocity-time ($v-t$) graph for this motion is shown in the following figure.

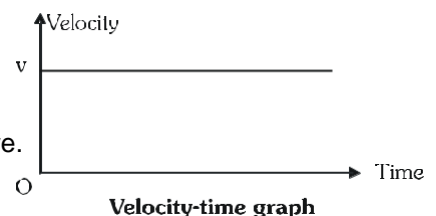

As we know that, the area between $v-t$ graph and the time axes equals to change in position i.e displacement, the position–time relationship or position at any instant can be obtained.

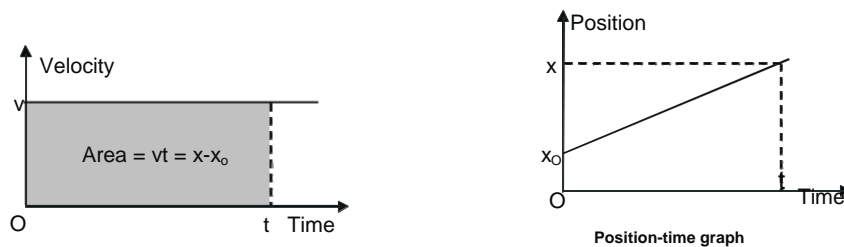

Uniform Acceleration Motion

Motion in which acceleration remains constant in magnitude as well as direction is called uniform acceleration motion. In the motion diagram, is shown a particle moving in positive x -direction with uniform acceleration a . It passes the position x_0 , moving with velocity v_0 at the instant $t = 0$ and acquires velocity v at a latter instant t .

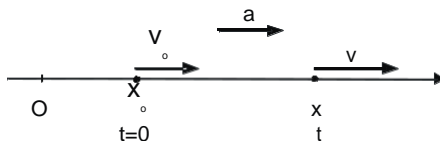

$$dv = a dt \Rightarrow \int_{v_0}^v dv = a \int_0^t dt \Rightarrow v - v_0 = at$$

$$v = v_0 + at \quad \dots(i)$$

Now from the above equation, we have $dx = v dt \Rightarrow \int_{x_0}^x dx = \int_0^t (v_0 + at) dt \Rightarrow x - x_0 = v_0 t + \frac{1}{2} at^2$

$$x = x_0 + v_0 t + \frac{1}{2} at^2 \quad \dots(ii)$$

Eliminating time t , from the above two equations, we have $v^2 = v_0^2 + 2a(x - x_0) \dots(iii)$

Equations (i), (ii) and (iii) are known as the first, second and third equations of motion for uniformly accelerated bodies. Acceleration–time ($a-t$) graph for this motion is shown in the following figure.

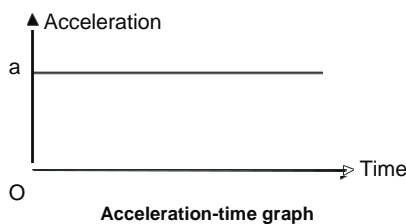

As we know that, the area between $a-t$ graph and the time axes equals to change in velocity, velocity–time relation or velocity at any instant can be obtained.

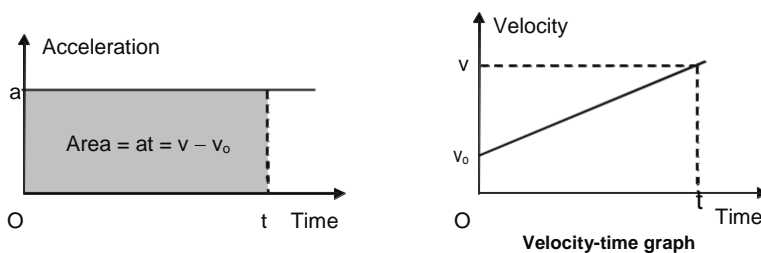

The area between $v-t$ graph and the time axes equals to change in position. Therefore, position–time relation or position at any instant can be obtained.

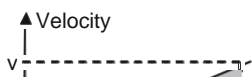

$$v_0 \quad \text{Area} = x - x_0 \quad \left(\frac{v_0 + v}{2} \right) t$$

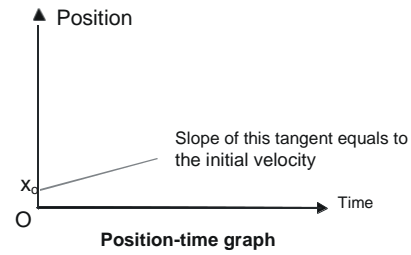

Ex am p l e

A particle moving with uniform acceleration passes the point $x = 2 \text{ m}$ with velocity 20 m/s at the instant $t = 0$. Some time later it is observed at the point $x = 32 \text{ m}$ moving with velocity 10 m/s .

- (a) What is its acceleration?
- (b) Find its position and velocity at the instant $t = 8 \text{ s}$.
- (c) What is the distance traveled during the interval $t = 0$ to 8 s ?

Solu ti on

In the adjoining figure the given and required information shown are not to a scale. As motion diagram is a schematic representation only.

- (a) Using the third equation of uniform acceleration motion, we have

$$v_t^2 = v_o^2 + 2a(x_t - x_o) \rightarrow a = \frac{v_t^2 - v_o^2}{2(x_t - x_o)} = \frac{10^2 - 20^2}{2(32 - 2)} = -5 \text{ m/s}^2$$

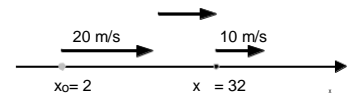

- (b) Using second equation of uniform acceleration motion, we have

$$x_t = x_o + v_o t + \frac{1}{2}at^2 \rightarrow x_8 = 2 + 20 \times 8 + \frac{1}{2}(-5)8^2 = 2 \text{ m}$$

Using the first equation of uniform acceleration motion, we have

$$v_t = v_o + at \rightarrow v_8 = 20 + (-5) \times 8 = -20 \text{ m/s}$$

- (c) Where the particle returns, its velocity must be zero. Using the third equation of uniform acceleration motion, we have

Edujournal

$$v^2 = v_o^2 + 2a(x - x_o) \rightarrow x = x_o + \frac{v^2 - v_o^2}{2a} = 2 + \frac{0 - 20^2}{2(-5)} = 42 \text{ m}$$

This location is shown in the adjoining modified motion diagram.

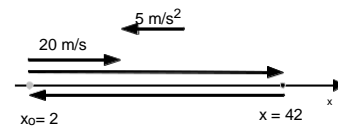

The distance-traveled Δs is $\Delta s = |x - x_o| + |x_o - x| = 80 \text{ m}$

Ex am p l e

A ball is dropped from the top of a building. The ball takes 0.50 s to fall past the 3 m length of a window, which is some distance below the top of the building.

- (a) How fast was the ball going as it passed the top of the window?
- (b) How far is the top of the window from the point at which the ball was dropped?

Assume acceleration g in free fall due to gravity be 10 m/s^2 downwards.

Solu ti on

The ball is dropped, so it start falling from the top of the building with zero initial velocity ($v_o = 0$). The motion diagram is shown with the given information in the adjoining figure.

Using the first equation of the constant acceleration motion, we have

$$v_t = v_0 + at \rightarrow v = 0 + 10t = 10t \quad \dots(i)$$

$$v' = 0 + 10(t + 0.5) = 10t + 5 \quad \dots(ii)$$

Using values of v and v' in following equation, we have

$$x - x_0 = \left(\frac{v + v'}{2} \right) t \rightarrow \text{window height} \left(\frac{v + v'}{2} \right) \times 0.5 \Rightarrow t = 0.35s$$

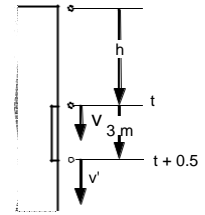

(o) From equation (i), we have $v = 10t = 3.5 \text{ m/s}$

(p) From following equation, we have

$$x - x_0 = \left(\frac{v_0 + v}{2} \right) (t - t_0) = \left(\frac{0 + v}{2} \right) (t - 0.35) \text{ cm}$$

Variable Acceleration Motion

More often, problems in rectilinear motion involve acceleration that is not constant. In these cases acceleration is expressed as a function of one or more of the variables t , x and v . Let us consider three common cases.

Acceleration given as function of time

If acceleration is a given function of time say $a = f(t)$, from equation $a = dv/dt$ we

$$\text{have } dv = f(t)dt \Rightarrow \int dv = \int f(t)dt$$

The above equation expresses v as function of time, say $v = g(t)$. Now substituting $g(t)$ for v in equation $v = dx/dt$, we have

$$dx = g(t) dt \Rightarrow \int dx = \int g(t)dt$$

The above equation yield position as function of time.

Example

The acceleration of a particle moving along the x -direction is given by equation $a = (3-2t) \text{ m/s}^2$. At the instants $t = 0$ and $t = 6 \text{ s}$, it occupies the same position.

- (a) Find the initial velocity v .
- (b) What will be the velocity at $t = 2 \text{ s}$?

Solution

By substituting the given equation in equation $a = dv/dt$, we have

$$dv = (3 - 2t) dt \Rightarrow \int_{v_0}^v dv = \int_0^t (3 - 2t)dt \Rightarrow v = v_0 + 3t - t^2 \quad \dots(i)$$

By substituting eq. (i) in equation $v = dx/dt$, we have

$$dx = (v_0 + 3t - t^2) dt \Rightarrow \int_{x_0}^x dx = \int_0^t (v_0 + 3t - t^2)dt \Rightarrow x = x_0 + v_0 t + \frac{3}{2} t^2 - \frac{1}{3} t^3 \quad \dots(ii)$$

(a) Applying the given condition that the particle occupies the same x coordinate at the instants $t = 0$ and $t = 6 \text{ s}$ in eq. (ii), we have

$$x_0 = x_6 \Rightarrow x_0 = x_0 + 6v_0 + 54 - 72 \Rightarrow v_0 = 3 \text{ m/s}$$

(b) Using v in eq. (i), we have $v = 3 + 3t - t^2 \Rightarrow v = 5 \text{ m/s}$

Acceleration as function of position

If acceleration is a given function of position say $a = f(x)$, we have to use equation $a = vdv/dx$. Rearranging term in this equation we have $vdv = adx$. Now substituting $f(x)$ for a , we have

$$vdv = f(x) dx \Rightarrow \int vdv = \int f(x)dx$$

The above equation provides us with velocity as function of position. Let relation obtained in this way is $v = g(x)$. Now substituting $g(x)$ for v in equation $v = dx/dt$, we have

$$dt = \frac{dx}{g(x)} \Rightarrow \int dt = \int \frac{dx}{g(x)}$$

The above equation yields the desired relation between x and t .

Example

Acceleration of a particle moving along the x -axis is defined by the law $a = -4x$, where a is in m/s^2 and x is in meters. At the instant $t = 0$, the particle passes the origin with a velocity of 2 m/s moving in the positive x -direction.

- Find its velocity v as function of its position coordinates.
- Find its position x as function of time t .
- Find the maximum distance it can go away from the origin

Solution

- (a) By substituting given expression in the equation $a = v dv/dx$ and rearranging, we have

$$vdv = -4x dx \Rightarrow \int_0^v vdv = -4 \int_0^x xdx \Rightarrow v = \pm 2\sqrt{1-x^2} \rightarrow v = 2\sqrt{1-x^2}$$

Edujournal

Since the particle passes the origin with positive velocity of 2 m/s, so the minus sign in the eq. (i) has been dropped.

- (b) By substituting above obtained expression of velocity in the equation $v = dx/dt$ and rearranging, we have

$$\frac{dx}{\sqrt{1-x^2}} = 2dt \Rightarrow \int_0^x \frac{dx}{\sqrt{1-x^2}} = 2 \int_0^t dt \Rightarrow \sin^{-1}(x) = 2t \rightarrow x = \sin 2t$$

- (c) The maximum distance it can go away from the origin is 1m because maximum magnitude of sine function is unity.

Acceleration as function of velocity

If acceleration is given as function of velocity say $a=f(v)$, by using equation $a = dv/dt$ we can obtain velocity as function of time.

$$dt = \frac{dv}{f(v)} \Rightarrow \int dt = \int \frac{dv}{f(v)}$$

Now using equation $v = dx/dt$ we can obtain position as function of time

In another way if we use equation $a = vdv/dx$, we obtain velocity as function of position.

$$dx = \frac{v dv}{f(v)} \Rightarrow \int dx = \int \frac{v dv}{f(v)}$$

Now using equation $v = dx/dt$ we can obtain position as function of time

Example

Acceleration of particle moving along the x-axis varies according to the law $a = -2v$, where a is in m/s^2 and v is in m/s . At the instant $t = 0$, the particle passes the origin with a velocity of 2 m/s moving in the positive x-direction.

- Find its velocity v as function of time t .
- Find its position x as function of time t .
- Find its velocity v as function of its position coordinates.
- Find the maximum distance it can go away from the origin.
- Will it reach the above-mentioned maximum distance?

Solution

- (a) By substituting the given relation in equation $a = dv/dt$, we have

$$\frac{dv}{v} = -2dt \Rightarrow \int \frac{v}{v} = -2 \int dt \rightarrow v = 2e^{-2t} \quad \dots(i)$$

- (b) By substituting the above equation in $v = dx/dt$, we have

$$dx = 2e^{-2t} dt \Rightarrow \int dx = 2 \int e^{-2t} dt \rightarrow x = 1 - 2e^{-2t} \quad \dots(ii)$$

cover this distance. Edujournal

- (c) Substituting given expression in the equation $a = v dv/dx$ and rearranging, we have

$$dv = -2dx \Rightarrow \int dv = -2 \int dx \rightarrow v = 2(1 - x) \quad \dots(iii)$$

- (d) Eq. (iii) suggests that it will stop at $x = 1 \text{ m}$. Therefore, the maximum distance away from the origin it can go is 1 m .
- (e) Eq. (ii) suggests that to cover 1 m it will take time whose value tends to infinity. Therefore, it can never

Projectile Motion

An object projected by an external force when continues to move by its own inertia is known as projectile and its motion as projectile motion.

A football kicked by a player, an arrow shot by an archer, water sprinkling out a water-fountain, an athlete in long jump or high jump, a bullet or an artillery shell fired from a gun are some examples of projectile motion.

In simplest case when a projectile does reach great

heights above the ground as well as does not cover a very large distance on the ground, acceleration due to gravity can be assumed uniform throughout its motion. Moreover, such a projectile does not spend much time in air not permitting the wind and air resistance to gather appreciable effects. Therefore, while analyzing them, we can assume gravity to be uniform and neglect effects of wind as well as air resistance. Under these circumstances when an object is thrown in a direction other than the vertical, its trajectory assumes shape of a parabola. In the figure, a ball thrown to follow a parabolic trajectory is shown as an example of projectile motion.

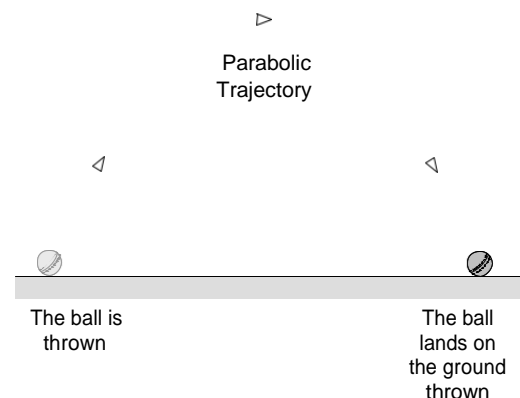

At present, we study projectiles moving on parabolic trajectories and by the term projectile motion; we usually refer to this kind of motion.

For a projectile to move on parabolic trajectory, the following conditions must be fulfilled.

- Acceleration vector must be uniform.
- Velocity vector never coincides with line of acceleration vector.

Analyzing Projectile motion

Since parabola is a plane curve, projectile motion on parabolic trajectory becomes an example of a two-dimensional motion. It can be conceived as superposition of two simultaneous rectilinear motions in two mutually perpendicular directions, which can be analyzed separately as two Cartesian components of the projectile motion.

Projectile Motion near the Horizontal or Flat Ground using Cartesian components

Consider motion of a ball thrown from ground as shown in the figure. The point from where it is projected is known as point of projection, the point where it falls on the ground is known as point of landing or target. The distance between these two points is known as horizontal range or range, the height from the ground of the highest point it reaches during flight is known as maximum height and the duration for which it remain in the air is known as air time or time of flight. The velocity with which it is thrown is known as velocity of projection and angle which velocity of projection makes with the horizontal is known as angle of projection.

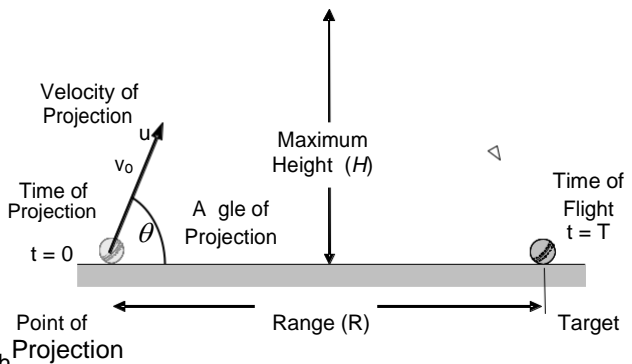

A careful observation of this motion reveals that when a ball is thrown its vertical component of velocity decreases in its upward motion, vanishes at the highest point and thereafter increases in its downward motion due to gravity similar to motion of a ball thrown vertically upwards. At the same time, the ball continues to move uniformly in horizontal direction due to inertia. The actual projectile motion on its parabolic trajectory is superposition of these two simultaneous rectilinear motions.

In the following figure, the above ideas are shown representing the vertical by y-axis and the horizontal by x-axis.

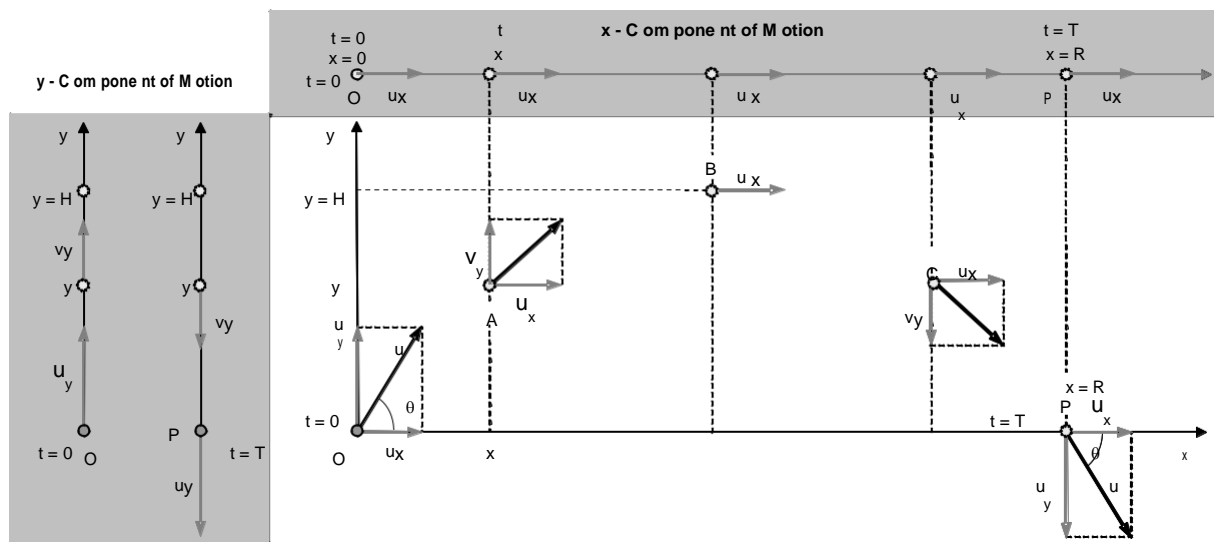

Projectile motion resolved into its two Cartesian components. Projectile motion as a superposition of two rectilinear motions one in vertical and other in horizontal direction.

Vertical or y-component of motion.

Component of initial velocity in the vertical direction is u_y . Since forces other than gravitational pull of the earth are negligible, vertical component of acceleration a_y of the ball is g vertically downwards. This component of motion is described by the following three equations. Here v_y denotes y-component of velocity, y denotes position coordinate y at any instant t .

$$v_y = u_y - gt \quad \dots(i) \qquad y = u_y t - \frac{1}{2}gt^2 \quad \dots(ii) \qquad v_y^2 = u_y^2 - 2gy \quad \dots(iii)$$

Horizontal or x-component of motion.

Since effects of wind and air resistance are assumed negligible as compared to effect of gravity, the horizontal component of acceleration of the ball becomes zero and the ball moves with uniform horizontal component of velocity u_x . This component of motion is described by the following equation.

$$x = u_x t \quad \dots(iv)$$

Equation of trajectory

Equation of the trajectory is relation between the x and the y coordinates of the ball without involvement of time t . To eliminate t , we substitute its expression from equation (iv) into equation (ii).

$$y = x \tan \theta - \frac{g}{2u_x^2 \cos^2 \theta} x^2 \quad \dots(v)$$

Every projectile motion can be analyzed using the above five equations. In a special case of interest, if the projectile lands the ground again, its time of flight, the maximum height reached and horizontal range are obtained using the above equations.

Time of Flight At the highest point of trajectory when $t = \frac{T}{2}$, the vertical component of velocity becomes zero. At the instant $t = T$, the ball strikes the ground with vertical component of velocity $v_y = -u_y$. By substituting either of these conditions in equation (i), we obtain the time of flight.

$$T = \frac{2u_y}{a_y} = \frac{2u_y}{g}$$

Maximum Height At the highest point of trajectory where $y = H$, the vertical component of velocity becomes zero. By substituting this information in equation (iii), we obtain the maximum height.

$$H = \frac{u_y^2}{2g}$$

Horizontal Range The horizontal range or simply the range of the projectile motion of the ball is distance traveled on the ground in its whole time of flight.

$$R = u_x T = \frac{2u_x u_y}{g} = \frac{u^2 \sin 2\theta}{g}$$

Maximum Range It is the maximum distance traveled by a projectile in the horizontal direction for a certain velocity of projection.

The above expression of range makes obvious that to obtain maximum range the ball must be projected at angle $\theta = 45^\circ$.

Substituting this condition in the expression of range, we obtain the maximum range R_m .

$$R_m = \frac{u^2}{g}$$

Trajectory Equation alternate form If range is known in advance, the equation of trajectory can be written in an alternative form involving horizontal range.

$$y = x \tan \theta \left(1 - \frac{x}{R} \right)$$



Example

A ball is thrown with 25 m/s at an angle 53° above the horizontal. Find its time of flight, maximum height and range.

Solution

In the adjoining figure velocity of projection $u = 25$ m/s, angle of projection $\theta = 53^\circ$, the horizontal and vertical components u_x and u_y of velocity of projection are shown. From these information we have

$$u_x = u \cos 53 = 15 \text{ m/s and } u_y = u \sin 53 = 20 \text{ m/s}$$

Using equations for time of flight T , maximum height H and range R , we have

$$T = \frac{2u_y}{g} = \frac{2 \times 20}{10} = 4 \text{ s}$$

$$H = \frac{u_y^2}{2g} = \frac{20^2}{2 \times 10} = 20 \text{ m}$$

$$R = \frac{2u_x u_y}{g} = \frac{2 \times 15 \times 20}{10} = 60 \text{ m}$$

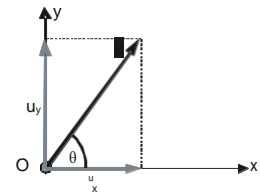

Example

A ball 4 s after the instant it was thrown from the ground passes through a point P, and strikes the ground after 5 s from the instant it passes through the point P. Assuming acceleration due to gravity to be 9.8 m/s² find height of the point P above the ground.

Solution

The ball projected with velocity $u = u_x \hat{i} + u_y \hat{j}$ from O reaches the point P with velocity $v = u_x \hat{i} + v_y \hat{j}$ and hits the ground at point Q at the instant $T = 4 + 5 = 9$ s as shown in the adjoining motion diagram.

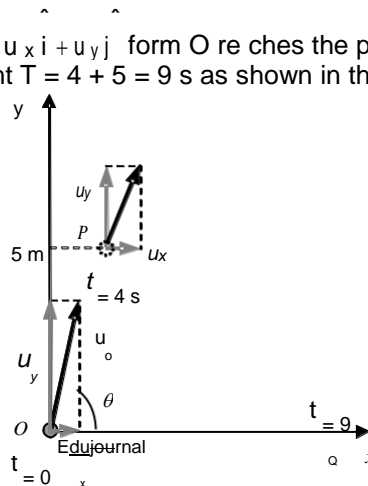

From equation of time of flight, we have its initial y-component of velocity $u_y = \frac{2u_y}{g} T \rightarrow u_y = \frac{1}{2} g T$

Substituting above in eq. (ii) and rearranging terms, we have the height y of the point P.

$$y = u_y t - \frac{1}{2} g t^2 \rightarrow y = \frac{1}{2} g t (T - t) = \frac{1}{2} \times 9.8 \times 4 (9 - 4) = 98 \text{ m}$$

Projectile on inclined plane

Artillery application often finds target either up a hill or down a hill. These situations can approximately be modeled as projectile motion up or down an inclined plane.

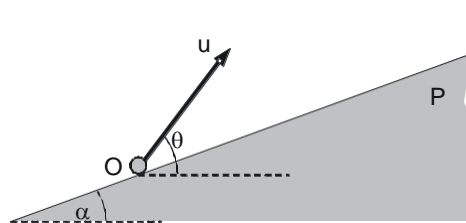

Projectile up an inclined plane

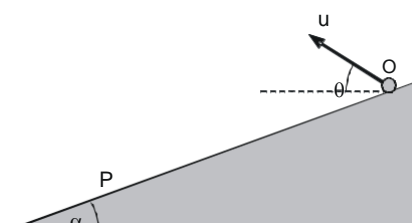

Projectile down an inclined plane

In the above left figure is shown a shell projected from a point O with velocity u at an angle θ to hit a target at point P uphill. This projectile motion is called projectile up a hill or inclined plane. Similarly in the above right figure is shown a projectile down a hill or inclined plane.

Analyzing projectile motion up an inclined plane using Cartesian components

Consider the projectile motion up an inclined plane described earlier. Assume a Cartesian coordinate system whose x-axis coincides with the line of fire OP and the origin with the point of projection as shown. The line OP is along the line of the greatest slope.

Velocity of projection makes angle $\theta - \alpha$ with the positive x-axis, therefore its x and y-components u_x and u_y are

$$u_x = u \cos(\theta - \alpha)$$

$$u_y = u \sin(\theta - \alpha)$$

Acceleration due to gravity g being vertical makes the angle α with the negative y-axis, therefore x and y-components of acceleration vector are

$$a_x = g \sin \alpha$$

$$a_y = g \cos \alpha$$

Motion component along the y-axis

The projectile starts with initial y-component of velocity u_y in the positive y-direction and has uniform y-component of acceleration $a_y = g \cos \alpha$ in the negative y-direction. This component of motion is described by the following three equations. Here v_y denotes y-component of velocity, y denotes position coordinate y at any instant t.

$$v_y = u_y - a_y t \quad \dots(i)$$

$$y = u_y t - \frac{1}{2} a_y t^2 \quad \dots(ii)$$

$$v_y^2 = u_y^2 - 2 a_y y \quad \dots(iii)$$

Motion component along the x-axis

The x-component of motion is also uniformly accelerated motion. The projectile starts with initial x-component of velocity u_x in the positive x-direction and has uniform x-component of acceleration a_x in the negative x-direction. This component of motion is described by the following three equations. Here v_x denotes x-component of velocity, x denotes position coordinate x at any instant t.

$$v_x = u_x - a_x t \quad \dots(iv)$$

$$x = u_x t - \frac{1}{2} a_x t^2 \quad \dots(v)$$

$$v_x^2 = u_x^2 - 2 a_x x \quad \dots(vi)$$

Every projectile motion up an incline can be analyzed using the above six equations. Quantities of interest in artillery applications and hence in projectile on incline plane are time of flight, range on the incline plane and the angle at which the shell hits the target.

Time of flight.

Moving in air for time interval T the projectile when hits the target P, its y-component of velocity u_y becomes in the negative y-direction. Using this information in equation (i), we obtain the time of flight.

$$T = \frac{2u_y}{a_y} = \frac{2u \sin(\theta - \alpha)}{g \cos \alpha}$$

When the projectile hits the target P, its y component of displacement also becomes zero. This information with equation (ii) also yield the time of flight.

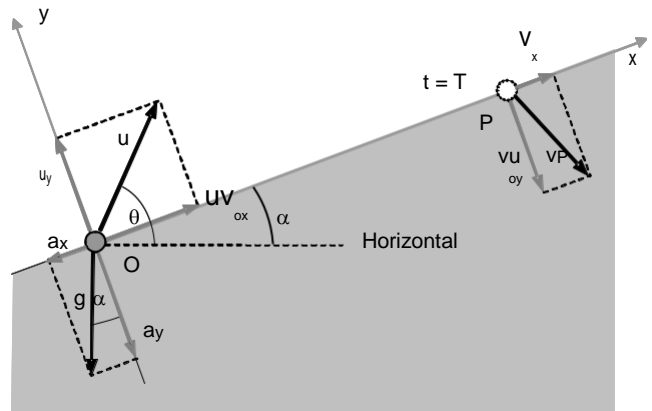

P projectile motion up an inclined plane resolved in to its two Cartesian components .

Edujournal



Range on the plane. The range of a projectile on an incline plane is the distance between the point of projection and the target. It equals to displacement in the x-direction during whole flight. By substituting time of flight in equation (v), we obtain expression for the range R.

$$R = \frac{2u \sin(\theta - \alpha) \cos \alpha}{g \cos^2 \alpha}$$

Analysis of projectile on an incline plane using Equation of trajectory

Sometimes the hill may be away from the point of projection or the hill may not have uniform slope as shown in the following two figures.

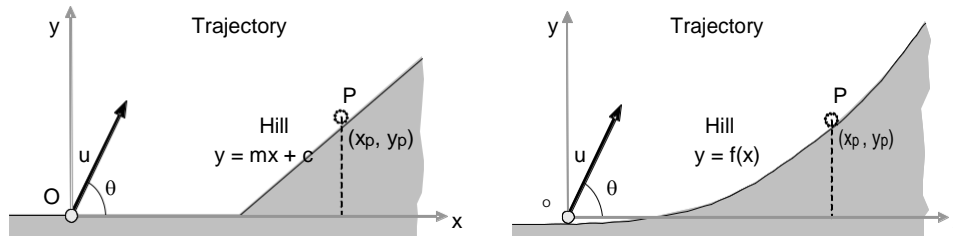

In these cases, the shape of the hill can be expressed by a suitable equation of the form $y = mx + c$ for uniform slope hill or $y = f(x)$ for nonuniform slope hill. The target P where the projectile hits the hill is the intersection of trajectory of the projectile and the hill. Therefore, coordinates (x_p, y_p) of the target can be obtained by simultaneously solving equation of the hill and equation of trajectory of the projectile.

Time of flight

Since a projectile move with uniform horizontal component of the velocity (u_x), its time of flight T can be calculated from the following equation.

$$T = \frac{x_p}{u \cos \theta}$$

Example

A particle is projected with velocity of 30 m/s at an angle 60° above the horizontal on a slope of inclination 30° . Find its range, time of flight and angle of hit.

Sol . The coordinate system, projection velocity and its component, and acceleration due to gravity and its component are shown in the adjoining figure.

Substituting corresponding values in following equation, we get the time of flight.

$$T = \frac{2u_y}{a_y} \rightarrow T = \frac{2 \times 15}{5\sqrt{3}} = 2\sqrt{3} \text{ s}$$

Substituting value of time of flight in following equation, we get the range R.

$$R = u_x T - \frac{1}{2} a_x T^2 \Rightarrow R = 15 \times 2\sqrt{3} - \frac{1}{2} \times 5 \times (2\sqrt{3})^2 = 60 \text{ m}$$

In the adjoining figure, components of velocity v_p when the projectile hits the slope at point P are shown. The angle β which velocity vector makes with the x-axis is known as angle of hit. The projectile hits the slope with such a

velocity v_p , whose y-component is equal in magnitude to that of velocity of projection. The x-component of velocity v_x is calculated by substituting value of time of flight in following equation.

$$v_x = u_x - a_x t \rightarrow v_x = 15\sqrt{3} - 5 \times 2\sqrt{3} = 5\sqrt{3}$$

$$\beta = \tan^{-1} \left(\frac{v_y}{v_x} \right) \rightarrow \beta = 60^\circ$$

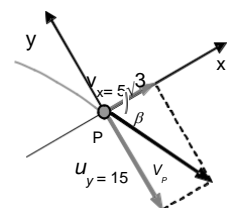
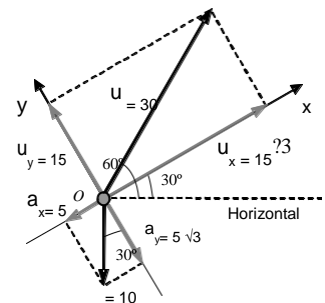

Relative Motion

Motion of a body can only be observed, when it changes its position with respect to some other body. In this sense, motion is a relative concept. To analyze motion of a body say A, therefore we have to fix our reference frame to some other body say B. The result obtained is motion of body A relative to body B.

Relative position, Relative Velocity and Relative Acceleration

Let two bodies represented by particles A and B at positions defined by

position vectors r_A and r_B , moving with velocities v_A and v_B and accelerations a_A and a_B with respect to a reference frame S. For analyzing motion of terrestrial bodies the reference frame S is fixed with the ground.

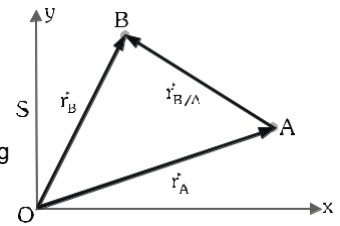

The vectors $r_{B/A}$ denotes position vector of B relative to A. Following triangle law of vector addition, we have

$$r_B = r_A + r_{B/A} \quad \dots(i)$$

First derivatives of r_A and r_B with respect to time equals to velocity of particle A and velocity of particle B relative to frame S and first derivative of $r_{B/A}$ with respect to time defines velocity of B relative to A.

$$v_B = v_A + v_{B/A} \quad \dots(ii)$$

Second derivatives of r_A and r_B with respect to time equals to acceleration of particle A and acceleration of particle B relative to frame S and second derivative of $r_{B/A}$ with respect to time defines acceleration of B relative to A.

$$a_B = a_A + a_{B/A} \quad \dots(iii)$$

In similar fashion motion of particle A relative to particle B can be analyzed with the help of adjoining figure. You can observe in the figure that position vector of A relative to B is directed from B to A and therefore

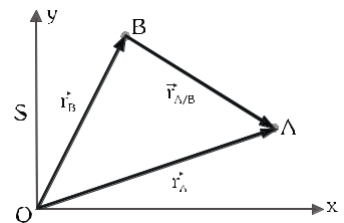

$$r_{B/A} = -r_{A/B}, \quad v_{B/A} = -v_{A/B} \text{ and } a_{B/A} = -a_{A/B}.$$

Example

The above equations elucidate how a body A appears moving

to another body B is opposite to how body B appears moving to body A.

A man when standstill observes the rain falling vertically and when he walks at 4 km/h he has to hold his umbrella at an angle of 53° from the vertical. Find velocity of the raindrops.

Solution

Assigning usual symbols v_m , v_r and $v_{r/m}$ to velocity of man, velocity of rain and velocity of rain relative to man, we can express their relationship by the following eq.

$$v_r = v_m + v_{r/m}$$

The above equation suggests that a standstill man observes velocity v_r of rain relative to the ground and while he is moving with velocity v_m , he observes velocity of rain relative to himself $v_{r/m}$. It is a common intuitive fact that umbrella must be held against $v_{r/m}$ for optimum protection from rain. According to these facts, directions of the

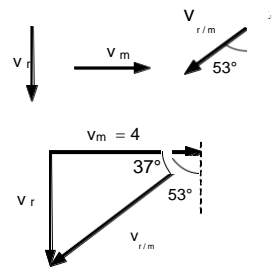

velocity vectors are shown in the adjoining figure.

The addition of velocity vectors is represented according to the above equation is also represented. From the figure we have

$$v_r = v_m \tan 37^\circ = 3 \text{ km/h}$$

Example

A boat can be rowed at 5 m/s on still water. It is used to cross a 200 m wide river from south bank to the north bank. The river current has uniform velocity of 3 m/s due east.

- (a) In which direction must it be steered to cross the river perpendicular to current?
- (b) How long will it take to cross the river in a direction perpendicular to the river flow?
- (c) In which direction must the boat be steered to cross the river in minimum time? How far will it drift?

Solution

(a) Velocity of a boat on still water is its capacity to move on water surface and equals to its velocity relative to water.

$v_{b/w}$ = Velocity of boat relative to water = Velocity of boat on still water

On flowing water, the water carries the boat along with it. Thus

velocity v_b of the boat relative to the ground equals to vector sum of

$v_{b/w}$ and v_w . The boat crosses the river with the velocity v_b .

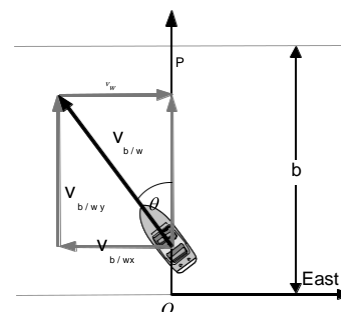

$$v_b = v_{b/w} + v_w$$

(b) To cross the river perpendicular to current the boat must be steered in a direction so that one of the components of its velocity ($v_{b/w}$) relative to water becomes equal and opposite to water flow velocity v_w to neutralize its effect. It is possible only when velocity of boat relative to water is greater than water flow velocity. In the adjoining figure it is shown that the boat starts from the point O and moves along the line OP (y-axis) due north relative to ground with velocity v_b . To achieve this it is steered at an angle θ with the y-axis.

$$v_{b/w} \sin \theta = v_w \rightarrow 5 \sin \theta = 3 \Rightarrow \theta = 37^\circ$$

(c) The boat will cover river width b with velocity

$$v_b = v_{b/wy} = v_{b/w} \sin 37^\circ = 4 \text{ m/s in time } t, \text{ which is given by}$$

$$t = b / v_b \rightarrow t = 50s$$

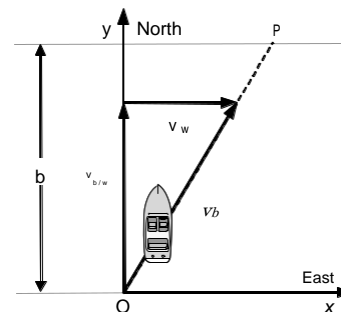

(d) To cross the river in minimum time, the component perpendicular to current of its velocity relative to ground must be kept to maximum value. It is achieved by steering the boat always perpendicular to current as shown in the adjoining figure. The boat starts from O at the south bank and reaches point P on the north bank. Time t taken by the boat is given by

$$t = b / v_{b/w} \rightarrow t = 40s$$

Drift is the displacement along the river current measured from the starting point. Thus, it is given by the following equation. We denote it by x_d .

$$x_d = v_{bx} t$$

Substituting $v_{bx} = v_w = 3$ m/s, from the figure, we have

$$x_d = 120 \text{ m}$$

Dependant Motion or Constraint Motion

Effect of motion of one body on another, when they are interconnected through some sort of physical link of a definite property is what we study in dependant motion.

The definite property of the connecting link is a constraint that decides how motion of one body depends on that of the other. Therefore, dependant motion is also known as constraint motion.

In various physical situations, we often encounter interconnected bodies affecting motion of each other. The variety of connecting link may be a string, a rod or a direct contact. A string has a definite length and can only pull a body, it cannot push; a rod also has definite length and can pull or push a body, bodies in direct smooth contact can only push each other. These problems are analyzed by the following methods.

Method of constraint equation

In this method, a property of connecting link is expressed in terms of position coordinates of the bodies. This equation is known as constraint equation. Differentiating the constraint equation once with respect to time we get relationship between their velocities and again differentiating the velocity relation with respect to time we get relationship between their accelerations.

Method of Vir tual Work

In this method, we use concepts of force and work. Work is defined as scalar product of force and displacement of the point of application of force. If two bodies are connected by inextensible links or links of constant length, the sum of scalar products of forces applied by connecting links and displacement of contact points at the ends of the connecting links equals to zero in every infinitesimally small time interval.

Let the forces applied by the connecting links on connected bodies are $F_1, F_2, \dots, F_i, \dots, F_n$ and displacements of corresponding contact points in an infinitesimally small time interval dt are $dr_1, dr_2, \dots, dr_i, \dots, dr_n$.

The principle suggest that
$$\sum_{i=1}^n \mathbf{r}_i \cdot d\mathbf{r}_i = 0$$

The relation between speeds of the contact point can direct y be obtained by dividing the equation with time interval dt .
Edujournali=1

$$\sum_{i=1}^n \mathbf{F}_i \cdot \mathbf{v}_i = 0$$

When angle between force vectors and velocity vectors do not vary with time, we can differentiate the above equation to obtain relationship between accelerations. However, care must be taken in deciding acceleration relation, when angle between force vectors and velocity vectors vary with time. In these circumstances, we may get an additional term involving the derivative of the angle between the force and the velocity. Therefore, at present we restrict ourselves to se this method when angle between force and velocity vectors remain constant. In these situations, we have

$$\sum \mathbf{F}_i \cdot \mathbf{v}_i = 0$$

Ex am p l e

In the system shown, the block A is moving down with velocity v_1 and C is moving up with velocity v_3 . Express velocity of the block B in terms of velocities of the blocks A and C.

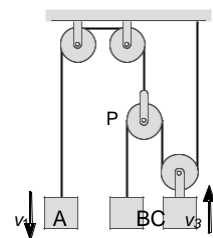

Solu ti on

Method of Constrained Equations.

The method requires assigning position coordinate to each of the moving bodies and making constraint equation for each string.

In the given system, there are four separately moving bodies and two strings. The moving bodies are the three blocks and one pulley P. We assign position coordinates x_1, x_2, x_3 and x_p all measured from the fixed reference ceiling as shown in the figure. The required constraint equation

for string connecting block A and pulley P is $x_1 + x_p = 1 \dots(i)$

And the required constraint equation for the other string is $x_2 + 2x_3 - 2x_p = 2 \dots(ii)$

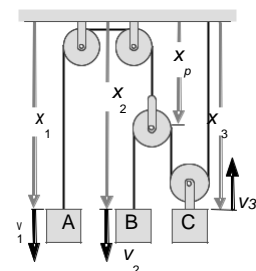

Let the block B is moving down with velocity v_2 . The velocities are defined as $v_1 = x_1$, $v_2 = x_2$, and $v_3 = -x_3$

Differentiating terms of eq. (i) and (ii), eliminating x_p and substituting above values of velocities, we have

$$v_2 = 2(v_3 - v_1)$$

Method of Virtual Work.

The tension forces applied by the strings on each contact point and displacements of the blocks are shown in the adjacent figure.

Let the tension in the string connected to block B is T. The tension in the string connecting the block A and the pulley P must be 2T in order to justify Newton's Second Law for massless pulley P.

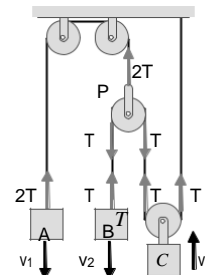

$$\sum F_i \cdot v_i = 0 \rightarrow -2Tv_1 - Tv_2 + 2Tv_3 = 0 \Rightarrow v_2 = 2(v_3 - v_1)$$

Visual Inspection with Superposition.

Motion of a body in an interconnected system equals to sum of individual effects of all other bodies. So velocity of block B equals to addition of individual effects of motion of A and C.

The individual effect of motion of A is velocity of B due to motion of A only and can easily be predicted by visual

inspection of the system. Let this individual effect be denoted by v_{BA}

$$v_{BA} = 2v_1 \dots (i)$$

Individual effect of motion of C on motion of B is

$$v_{BC} = 2v_3 \dots (ii)$$

According to the principle of superposition, velocity v_2 of block B equals to $v_2 = 2(v_3 - v_1)$

Describing Translation Motion by Angular Variables

Position of particle can completely be specified by its position vector r , if magnitude r of the position vector and its orientation relative to some fixed reference direction is known. In the given figure is shown a particle P at

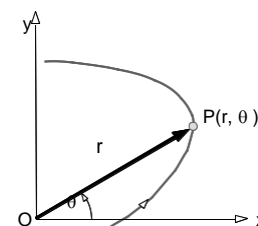

location shown by position vector $r = OP$. Magnitude of the position vector is distance $r = OP$ of the particle from the origin O and orientation of the position vector is the angle θ made by line OP with the positive x-axis. We now specify position of particle by these two variables r and θ , known as polar coordinates.

Edujournal

When the particle moves, either or both of these coordinates change with time. If a particle moves radially away from the origin, magnitude r of its position vector r increases without any change in angle θ . Similarly, if a particle moves radially towards the origin, r decreases without any change in angle θ . If a particle moves on a circular path with center at the origin, only the angle θ changes with time. If the particle moves on any path other than a radial straight line or circle centered at the origin, both of the coordinates r and θ change with time.

Angular Motion :

Change in direction of position vector r is known as angular motion. It happens when a particle moves on a curvilinear path or straight-line path not containing the origin as shown in the following figures.

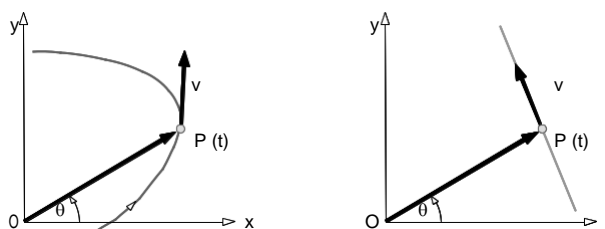

Angular Motion

Angular position : The coordinate angle θ at an instant is known as angular position of the particle.

Angular Displacement : A change in angular position θ in a time interval is known as angular displacement.

Angular Velocity : The instantaneous rate of change in angular position θ with respect to time is known as angular velocity.

We denote angular velocity by symbol ω .
$$\omega = \frac{d\theta}{dt}$$

Angular Acceleration : The instantaneous rate of change in angular velocity ω with respect to time is known as angular acceleration.

We denote angular acceleration by symbol α .
$$\alpha = \frac{d\omega}{dt} = \frac{d^2\theta}{dt^2} = \omega \frac{d\omega}{d\theta}$$

If a particle moves in a plane, the position vector turns either in clockwise or anticlockwise sense. Assuming one of these direction positive and other negative, problems of angular motion involving angular position θ , angular velocity ω and angular acceleration α can be solved in fashion similar to problems of rectilinear motion involving position x , velocity v , and acceleration a .

Kinematics of Circular Motion

A body in circular motion moves on a circular path. At present, we discuss only translation motion of a body on circular path and disregard any rotation; therefore, we represent the body as a particle.

In the given figure, a particle P is shown moving on a circular path of radius r . Here only for simplicity center of the circular path is assumed at the origin of a coordinate system. In general, it is not necessary to assume center at the origin. Position vector of the particle is shown by directed radius

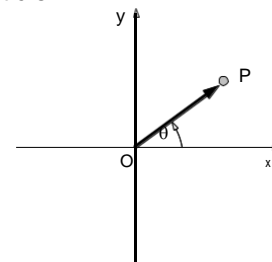

Therefore, it is also known as radius vector. The radius vector is always normal to the path and has constant magnitude and as the particle moves, it is the angular position θ , which varies with time.

Angular Variables in Circular Motion

Edujournal

Angular position θ , angular velocity ω and angular acceleration α known as angular variables vary in different manner depending on how the particle moves.

Motion with uniform angular velocity

If a particle moves with constant angular velocity, its angular acceleration is zero and position vector turns at constant rate. It is analogous to uniform velocity motion on straight line. The angular position θ at any instant of time t is expressed by the following equation.

$$\theta = \theta_0 + \omega t$$

Motion with uniform angular acceleration

If a particle moves with constant angular acceleration, its angular velocity changes with time at a constant rate. The angular position θ , angular velocity ω and the angular acceleration α bear relations described by the following equations, which have forms similar to corresponding equations that describe uniform acceleration motion.

$$\omega = \omega_0 + \alpha t$$

$$\theta = \theta_0 + \omega_0 t + \frac{1}{2} \alpha t^2$$

$$\theta = \theta_0 + \frac{1}{2} (\omega_0 + \omega) t$$

$$\omega^2 = \omega_0^2 + 2\alpha (\theta - \theta_0)$$

Motion with variable angular acceleration

Variable angular acceleration of a particle is generally specified as function of time, angular position or angular velocity. Problems involving variable angular acceleration can also be solved in a way analogous to corresponding rectilinear motion problems in which acceleration is specified as function of time, position or velocity.

Linear Velocity and Acceleration in circular Motion

The instantaneous velocity v and the instantaneous acceleration

a are also known as linear velocity and linear acceleration. In the figure is shown a particle moving on a circular path. As it moves it covers a distance s (arc length).

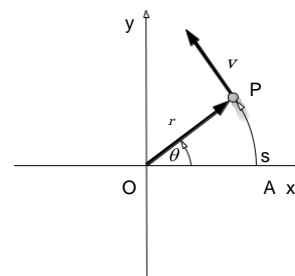

$$s = \theta r$$

Linear velocity v is always along the path. Its magnitude known as linear speed is obtained by differentiating s with respect to time t .

$$v = \frac{d\theta}{dt} r = \omega r$$

If speed of the particle is uniform, the circular motion is known as uniform circular motion. In this kind of motion as the particle proceeds further, only direction of velocity changes. Therefore, instantaneous acceleration or linear acceleration accounts for only change in direction of motion.

Consider a particle in uniform circular motion. It is shown at two infinitely close instants t and $t + dt$, where its velocity

vectors are V and $v + dv$. These two velocity vectors are equal in magnitude and shown in adjacent figure. From this figure, it is obvious that the change dv in velocity

vector is perpendicular to velocity vector v , i.e. towards the center. It can be approximated as arc of radius equal

to magnitude of v . Therefore we can write $|dv| = v \cdot d\theta$

Hence acceleration of this particle is towards the center. It is known as normal component of acceleration or more commonly centripetal acceleration.

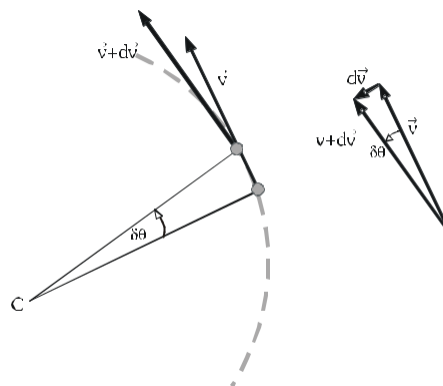

Dividing $|dv|$ by time interval dt we get magnitude of centripetal acceleration a_c .

$$a_c = \frac{dv}{dt} = \omega v = \omega^2 r = \frac{v^2}{r}$$

Acceleration and velocity of a particle in uniform circular motion are shown in the following figure.

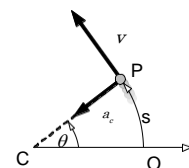

To keep the particle in uniform circular motion net force acting on it must be towards the center, therefore it is known as centripetal force.

If particle moves with varying speed, the net force on it must have a component along the direction of velocity vector in addition to the centripetal force. This component force is along the tangent to the path and produces a component of acceleration in the tangential direction. This component known as tangential component of acceleration a_T , accounts for change in speed.

$$a_T = \frac{dv}{dt} = \frac{d\omega}{dt} r = \alpha r$$

Example

Angular position θ of a particle moving on a curvilinear path varies according to the equation $\theta = t^3 - 3t^2 + 4t - 2$, where θ is in radians and time t is in seconds. What is its average angular acceleration in the time interval $t = 2s$ to $t = 4s$?

Solution

Like average linear acceleration, the average angular acceleration α_{av} equals to ratio of change in angular velocity $\Delta\omega$ to the concerned time interval Δt .

$$\alpha_{av} = \frac{\Delta\omega}{\Delta t} = \frac{\omega_{final} - \omega_{initial}}{t_{final} - t_{initial}} \dots(i)$$

The angular velocity ω being rate of change in angular position can be obtained by equation

$$\omega = \frac{d\theta}{dt}$$

Substituting the given expression of the angular position θ , we have

$$\omega = 3t^2 - 6t + 4 \dots(ii)$$

From the above eq. (ii), angular velocities ω_2 and ω_4 at the given instants $t = 2s$ and $4s$ are

$$\omega_2 = 4 \text{ rad/s} \quad \text{and} \quad \omega_4 = 28 \text{ rad/s}$$

Substituting the above values in eq. (1), we have $\alpha_{av} = 12 \text{ rad/s}^2$

Example

A particle starts from rest and moves on a curve with constant angular acceleration of 3.0 rad/s^2 . An observer starts his stopwatch at a certain instant and records that the particle covers an angular span of 120 rad at the end of 4^{th} second. How long the particle had moved when the observer started his stopwatch?

Solution

Let the instants when the particle starts moving and the observer starts his stopwatch, are $t_0=0$ to $t=t_1$. Denoting angular positions and angular velocity at the instant $t = t_1$ by θ_1 and ω_1 and the angular position at the instant $t_2 = t_1 + 4s$ by θ_2 , we can express the angular span covered during the interval from eq.

$$\theta - \theta_0 = \omega_0 t + \frac{1}{2} \alpha t^2 \rightarrow \theta_2 - \theta_1 = \omega_1 (t_2 - t_1) + \frac{1}{2} \alpha (t_2 - t_1)^2$$

Substituting values θ_1, θ_2, t_1 and t_2 , we have $\omega_1 = 24 \text{ rad/s}$

From eq. $\omega = \omega_0 + at$, we have $\omega_1 = \omega_0 + at_1$

Now substituting $\omega_0 = 0, \omega_1 = 24$ and $\alpha = 3 \text{ rad/s}^2$, we have $t_1 = 8.0 \text{ s}$

Example

A particle moves on a circular path of radius 8 m . Distance traveled by the particle in time t is given by the equation $s = 2t^3$. Find its speed when tangential and normal accelerations have equal magnitude.

Solution

The speed v , tangential acceleration a_t and the normal acceleration a_n are expressed by the following equations.

$$v = \frac{ds}{dt}$$

Substituting the given expression for s , we have $v = 2t^2$

$$a_t = \frac{d^2s}{dt^2} \dots(i)$$

Substituting the given expression for s , we have $a_{\tau} = 4t$

$$a_n = \frac{v^2}{r} \quad \dots(ii)$$

Substituting v from eq. (i) and $r = 8\text{m}$, we have $a_n = \frac{1}{2}t^4 \quad \dots(iii)$

The instant when the tangential and the normal accelerations have equal magnitude, can be obtained by equating their expressions given in eq. (ii) and (iii).

$$a_n = a_{\tau} \rightarrow t = 2\text{s}$$

Substituting the above value of t in eq. (i), we obtain $v = 8\text{ m/s}$

Example

A particle is moving on a circular path of radius 1.5 m at a constant angular acceleration of 2 rad/s^2 . At the instant $t = 0$, angular speed is $60/\pi\text{ rpm}$. What are its angular speed, angular displacement, linear velocity, tangential acceleration and normal acceleration at the instant $t = 2\text{ s}$.

Solution

Initial angular speed is given in rpm (revolution per minute). It is expressed in rad/s as

$$1\text{ rpm} = \frac{2\pi\text{ rad}}{60\text{ s}}$$

$$\omega_0 = \left(\frac{60}{\pi}\right) \times \frac{2\pi\text{ rad}}{60\text{ s}} = 2\text{ rad/s}$$

At the instant $t = 2\text{ s}$, angular speed ω_2 and angular displacement θ_2 are calculated by using eq.

$$\omega_2 = \omega_0 + \alpha t$$

Substituting values $\omega_0 = 2\text{ rad/s}$, $\alpha = 2\text{ rad/s}^2$, $t = 2\text{ s}$, we have

$$\omega_2 = 6\text{ rad/s}$$

$$\theta_2 = \theta_0 + \frac{1}{2}(\omega_0 + \omega_2)t$$

Substituting values $\theta_0 = 0$, $\omega_0 = 2\text{ rad/s}$, $\omega_2 = 6\text{ rad/s}$ and $t = 2\text{ s}$, we have

$$\theta_2 = 8\text{ rad}$$

Linear velocity at $t = 2\text{ s}$, can be calculated by using eq.

$$v_2 = r\omega_2$$

Substituting $r = 1.5\text{ m}$ and $\omega_2 = 6\text{ rad/s}$, we have

$$v_2 = 9\text{ m/s}$$

Tangential acceleration a_{τ} and normal acceleration a_n can be calculated by using eq. and respectively.

$$a_{\tau} = r\alpha$$

Substituting $r = 1.5\text{ m}$ and $\alpha = 2\text{ rad/s}^2$, we have

$$a_{\tau} = 3\text{ m/s}^2$$

$$a_n = \omega^2 r$$

Substituting $\omega_2 = 6\text{ rad/s}$ and $r = 1.5\text{ m}$, we have

$$a_n = 54\text{ m/s}^2$$

Example

A particle is moving in a circular orbit with a constant tangential acceleration. After 2 s from the beginning of motion, angle between the total acceleration vector and the radius R becomes 45° . What is the angular acceleration of the particle?

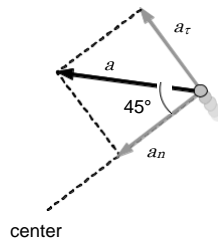

Solution

In the adjoining figure are shown the total acceleration vector a and its components the tangential accelerations a_t and normal accelerations a_n are shown. These two components are always mutually perpendicular to each other and act along the tangent to the circle and radius respectively. Therefore, if the total acceleration vector makes an angle of 45° with the radius, both the tangential and the normal components must be equal in magnitude. Now from eq. and , we have

$$a_t = a_n \rightarrow \alpha R = \omega^2 R \Rightarrow \alpha = \omega^2 \quad \dots(i)$$

Since angular acceleration is uniform, from eq., we have $\omega = \omega_0 + \alpha t$

Substituting $\omega_0=0$ and $t = 2$ s, we have $\omega = 2\alpha \quad \dots(ii)$

From eq. (i) and (ii), we have $\alpha = 0.25 \text{ rad/s}^2$

SOME WORKED OUT EXAMPLES

Example # 1

On an open ground a motorist follows a track that turns to his left by an angle of 60° after every 500 m. Starting from a given turn, specify the displacement of the motorist at the third, sixth and eighth turn. Compare the magnitude of displacement with the total path length covered by the motorist in each case.

Solution

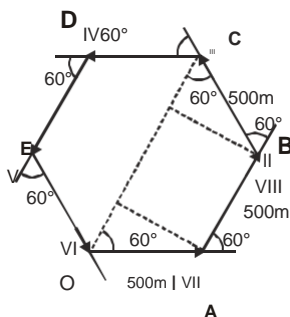

At III turn

$$\begin{aligned} \text{Displacement} &= OA + AB + BC = OC = 500 \cos 60^\circ + 500 + 500 \cos 60^\circ \\ &= 500 \times \frac{1}{2} + 500 + 500 \times \frac{1}{2} = 1000 \text{ m from O to C} \end{aligned}$$

$$\text{Distance} = 500 + 500 + 500 = 1500 \text{ m.} \quad \text{So } \frac{\text{Displacement}}{\text{Distance}} = \frac{1000}{1500} = \frac{2}{3}$$

At VI turn : initial and final positions are same so displacement

$$= 0 \text{ and distance} = 500 \times 6 = 3000 \text{ m} \therefore \frac{\text{Displacement}}{\text{Distance}} = \frac{0}{3000} = 0$$

$$\text{At VIII turn : Displacement} = \frac{2(500) \cos \left(\frac{60^\circ}{2} \right)}{2} = 1000 \times \cos 30^\circ = 1000 \times \frac{\sqrt{3}}{2} = 500\sqrt{3} \text{ m}$$

$$\text{Distance} = 500 \times 8 = 4000 \text{ m} \quad \therefore \frac{\text{Displacement}}{\text{Distance}} = \frac{500\sqrt{3}}{4000} = \frac{\sqrt{3}}{8}$$

Example # 2

A drunkard walking in a narrow lane takes 5 steps forward and 3 steps backward, followed again by 5 steps forward and 3 steps backward, and so on. Each step is 1m long and requires 1s. Plot the x-t graph of his motion. Determine graphically or otherwise how long the drunkard takes to fall in a pit 9m away from the start.

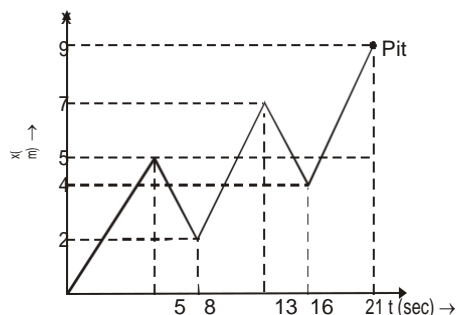

Solution

from x-t graph time taken = 21 s

OR

$$(5m - 3m) + (5m - 3m) + 5m = 9m \Rightarrow \text{total steps} = 21 \Rightarrow \text{time} = 21 \text{ s}$$

Example # 3

A man walks on a straight road from his home to a market 2.5 km away with a speed of 5 km/h. On reaching the market he instantly turns and walks back with a speed of 7.5 km/h. What is the

- (a) magnitude of average velocity and
- (b) average speed of the man, over the interval of time (i) 0 to 30 min. (ii) 0 to 50 min (iii) 0 to 40 min.

Solution

Time taken by man to go from his home to market, $t_1 = \frac{\text{distance}}{\text{speed}} = \frac{2.5}{5} = \frac{1}{2} \text{ h}$

Time taken by man to go from market to his home, $t_2 = \frac{2.5}{7.5} = \frac{1}{3} \text{ h}$

\therefore Total time taken = $t_1 + t_2 = \frac{1}{2} + \frac{1}{3} = \frac{5}{6} \text{ h} = 50 \text{ min.}$

(i) 0 to 30 min

Average velocity = $\frac{\text{displacement}}{\text{time interval}} = \frac{2.5}{\frac{30}{60}} = 5 \text{ km/h}$ towards market

Average speed = $\frac{\text{distance}}{\text{time interval}} = \frac{2.5}{\frac{30}{60}} = 5 \text{ km/h}$

(ii) 0 to 50 min

Total displacement = zero so average velocity = 0

So, average speed = $\frac{5}{50/60} = 6 \text{ km/h}$

Total distance travelled = 2.5 + 2.5 = 5 km.

(iii) 0 to 40 min

Distance covered in 30 min (from home to market) = 2.5 km.

Distance covered in 10 min (from market to home) with speed 7.5 km/h = $7.5 \times \frac{10}{60} = 1.25 \text{ km}$

So, displacement = 2.5 - 1.25 = 1.25 km (towards market)

Distance travelled = 2.5 + 1.25 = 3.75 km

Average velocity = $\frac{1.25}{\frac{40}{60}} = 1.875 \text{ km/h. (towards market)}$

Average speed = $\frac{3.75}{\frac{40}{60}} = 5.625 \text{ km/h.}$

Note : Moving body with uniform speed may have variable velocity. e.g. in uniform circular motion speed is constant but velocity is non-uniform.

Example # 4

A driver takes 0.20 s to apply the brakes after he sees a need for it. This is called the reaction time of the driver. If he is driving a car at a speed of 54 km/h and the brakes cause a deceleration of 6.0m/s², find the distance travelled by the car after he sees the need to put the brakes on ?

Solution

Distance covered by the car during the application of brakes by driver

$$s_1 = ut = \left(54 \times \frac{5}{18} \right) (0.2) = 15 \times 0.2 = 3.0 \text{ m}$$

After applying the brakes; $v = 0$, $u = 15 \text{ m/s}$, $a = 6 \text{ m/s}^2$ $s_2 = ?$

Using $v^2 = u^2 - 2as \Rightarrow 0 = (15)^2 - 2 \times 6 \times s_2 \Rightarrow 12s_2 = 225 \Rightarrow s_2 = \frac{225}{12} = 18.75 \text{ m}$

Distance travelled by the car after driver sees the need for it $s = s_1 + s_2 = 3 + 18.75 = 21.75 \text{ m}$.

Example # 5

A passenger is standing d distance away from a bus. The bus begins to move with constant acceleration a. To catch the bus, the passenger runs at a constant speed u towards the bus. What must be the minimum speed of the passenger so that he may catch the bus?

Sol . Let the passenger catch the bus after time t.

The distance travelled by the bus, $s_1 = 0 + \frac{1}{2} at^2 \dots(i)$

and the distance travelled by the passenger $s_2 = ut + 0 \dots(ii)$

Now the passenger will catch the bus if $d + s_1 = s_2 \dots(iii)$

$\Rightarrow d + \frac{1}{2} at^2 = ut \Rightarrow \frac{1}{2} at^2 - ut + d = 0 \Rightarrow t = \frac{[u \pm \sqrt{u^2 - 2ad}]}{a}$

So the passenger will catch the bus if t is real, i.e., $u^2 \geq 2ad \Rightarrow u \geq \sqrt{2ad}$

So the minimum speed of passenger for catching the bus is $\sqrt{2ad}$.

Example # 6

If a body travels half its total path in the last second of its fall from rest, find : (a) The time and (b) height of its fall. Explain the physically unacceptable solution of the quadratic time equation. ($g = 9.8 \text{ m/s}^2$)

Solution

If the body falls a height h in time t, then

$$h = \frac{1}{2} gt^2 \text{ [} u = 0 \text{ as the body starts from rest]} \dots (i)$$

Now, as the distance covered in (t - 1) second is $h' = \frac{1}{2} g(t-1)^2 \dots (ii)$

So from Equations (i) and (ii) distance travelled in the last second.

$$h - h' = \frac{1}{2} gt^2 - \frac{1}{2} g(t-1)^2 \text{ i.e., } h - h' = \frac{1}{2} g(2t-1)$$

But according to given problem as $(h - h') = \frac{h}{2}$

$$\Rightarrow \left(\frac{1}{2} \right) h = \left(\frac{1}{2} \right) \left(\frac{1}{2} \right) g(2t-1) \text{ or } \left(\frac{1}{2} \right) gt^2 = g(2t-1) \text{ [as from equation (i)] } \quad h = \left(\frac{1}{2} \right) gt^2$$

$$\Rightarrow t^2 - 4t + 2 = 0 \text{ or } t = [4 \pm \sqrt{(4^2 - 4 \times 2)}] / 2 \Rightarrow t = 2 \pm \sqrt{2} \Rightarrow t = 0.59 \text{ s or } 3.41 \text{ s}$$

0.59 s is physically unacceptable as it gives the total time t taken by the body to reach ground lesser than one sec while according to the given problem time of motion must be greater than 1s.

so $t = 3.41 \text{ s}$ and $h = \frac{1}{2} \times (9.8) \times (3.41)^2 = 57 \text{ m}$

Example # 7

A car accelerates from rest at a constant rate α for some time, after which it decelerates at a constant rate β , to come to rest. If the total time elapsed is t evaluate (a) the maximum velocity attained and (b) the total distance travelled.

Solution

(a) Let the car accelerates for time t_1 and decelerates for time t_2 then $t = t_1 + t_2 \dots (i)$ and corresponding velocity–time graph will be as shown in fig.

From the graph $\alpha = \text{slope of line OA} = \frac{V_{\max}}{t_1} \Rightarrow t_1 = \frac{V_{\max}}{\alpha}$

and $\beta = -\text{slope of line AB} = \frac{V_{\max}}{t_2} \Rightarrow t_2 = \frac{V_{\max}}{\beta}$

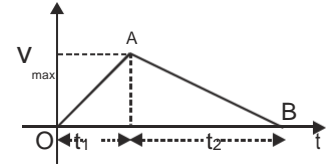

$$\Rightarrow \frac{V_{\max}}{\alpha} + \frac{V_{\max}}{\beta} = t \Rightarrow V_{\max} \left(\frac{\alpha + \beta}{\alpha\beta} \right) = t \Rightarrow V_{\max} = \frac{\alpha\beta t}{\alpha + \beta}$$

(b) Total distance = area under v–t graph = $\frac{1}{2} \times t \times V_{\max} = \frac{1}{2} \times t \times \frac{\alpha\beta t}{\alpha + \beta} = \frac{1}{2} \left(\frac{\alpha\beta t^2}{\alpha + \beta} \right)$

Note: This problem can also be solved by using equations of motion ($v = u + at$, etc.).

Example # 8

Edujour1nal

Draw displacement time and acceleration – time graph for the given velocity–time graph

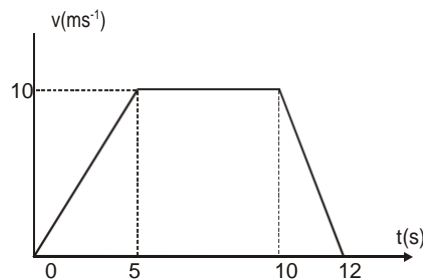

Solution

For $0 \leq t \leq 5$ $v \propto t \Rightarrow s \propto t^2$ and $a = \text{constant} = \frac{10}{5} = 2 \text{ ms}^{-2}$

for whole interval $s_1 = \text{Area under the curve} = \frac{1}{2} \times 5 \times 10 = 25 \text{ m}$

For $5 \leq t \leq 10$, $v = 10 \text{ ms}^{-1} \Rightarrow a = 0$

for whole interval $s_2 = \text{area under the curve} = 5 \times 10 = 50 \text{ m}$

For $10 \leq t \leq 12$ v linearly decreases with time $\Rightarrow a = -\frac{10}{2} = -5 \text{ ms}^{-2}$

for whole interval $s_3 = \text{Area under the curve} = \frac{1}{2} \times 2 \times 10 = 10 \text{ m}$

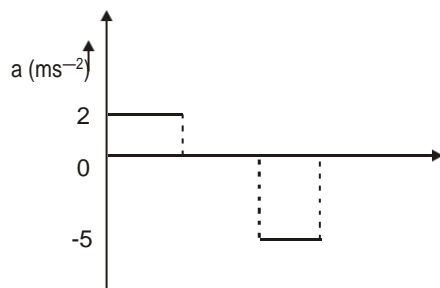
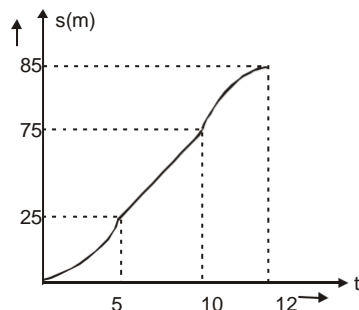

Example # 9

A rocket is fired upwards vertically with a net acceleration of 4 m/s^2 and initial velocity zero. After 5 seconds its fuel is finished and it decelerates with g . At the highest point its velocity becomes zero. Then it accelerates downwards with acceleration g and return back to ground. Plot velocity–time and displacement–time graphs for the complete journey. Take $g = 10 \text{ m/s}^2$.

Solution



In the graphs, $v_A = at_{OA} = (4)(5) = 20 \text{ m/s}$ $v_B = 0 = v_A - gt_{AB}$

$$\therefore t_{AB} = \frac{v_A}{g} = \frac{20}{10} = 2\text{s} \qquad \therefore t_{OAB} = (5+2)\text{s} = 7\text{s}$$

Now, $s_{OAB} = \text{area under } v\text{-}t \text{ graph between } 0 \text{ to } 7 \text{ s} = \frac{1}{2} (7)(20) = 70 \text{ m}$

Now, $s_{OAB} = s_{BC} = \frac{1}{2}gt^2_{BC} \qquad \therefore 70 = \frac{1}{2}(10)t^2_{BC}$

$$\therefore t_{BC} = \sqrt{14} = 3.7 \text{ s} \qquad \therefore t_{OABC} = 7+3.7 = 10.7\text{s}$$

Also $s_{OA} = \text{area under } v\text{-}t \text{ graph between } OA = \frac{1}{2} (5)(20) = 50 \text{ m}$

Example # 10

At the height of 500m, a particle A is thrown up with $v = 75 \text{ ms}^{-1}$ and particle B is released from rest. Draw, acceleration –time, velocity–time, speed–time and displacement–time graph of each particle.

For particle A :

Time of flight

$$-500 = +75t - \frac{1}{2} \times 10t^2$$

$$\Rightarrow t^2 - 15t - 100 = 0$$

$$\Rightarrow t = 20 \text{ s}$$

Time taken for A A₁ A₂

$$v = 0 = 75 - 10t \Rightarrow t = 7.5 \text{ s}$$

Velocity at A₃, $v = 75 - 10 \times 20 = -125 \text{ ms}^{-1}$

$$\text{Height A A}_1 = 75 \times 7.5 - \frac{1}{2} (10) (7.5)^2 = 281.25 \text{ m}$$

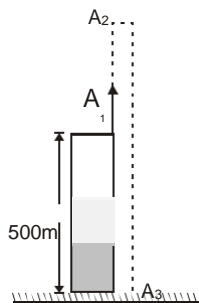

For Particle B

Time of flight

$$500 = \frac{1}{2} (10)t^2 \Rightarrow t = 10 \text{ s}$$

Velocity at B₂

$$v = 0 - (10)(10) = -100 \text{ ms}^{-1}$$

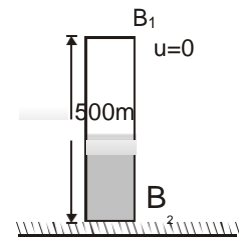

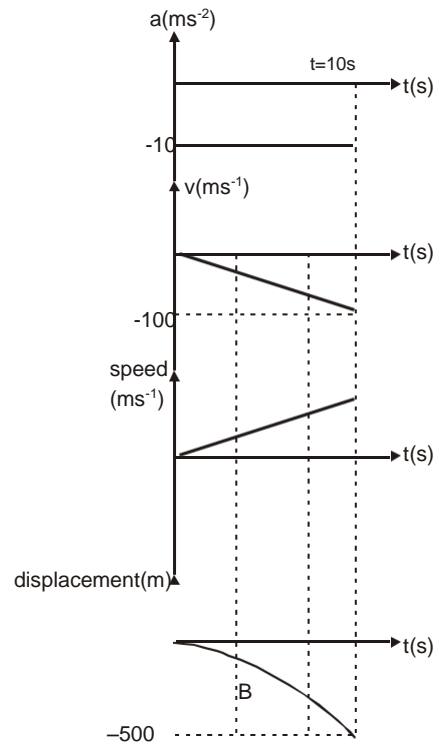
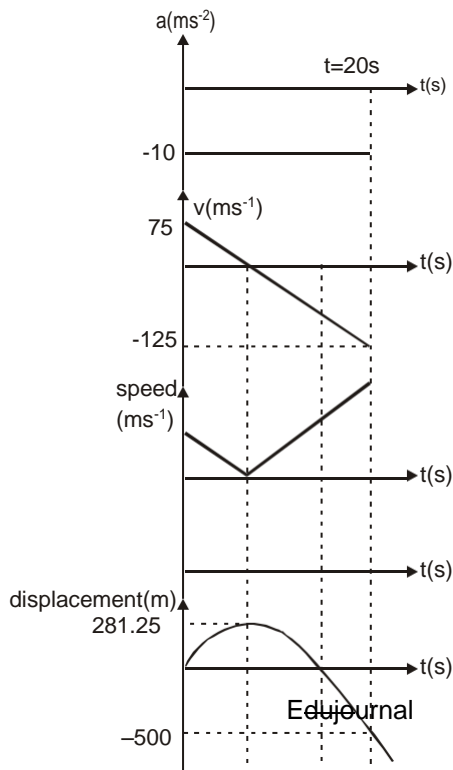

Example # 11

Two ships A and B are 10 km apart on a line running south to north. Ship A further north is streaming west at 20 km/h and ship B is streaming north at 20 km/h. What is their distance of closest approach and how long do they take to reach it?

Solution

Ships A and B are moving with same speed 20 km/h in the directions shown in figure. It is a two dimensional, two body problem with zero acceleration. Let us find v_{BA}

$$v_{BA} = v_B - v_A$$

Here, $|v_{BA}| = \sqrt{(20)^2 + (20)^2} = 20\sqrt{2}$ km/h

i.e., v_{BA} is $20\sqrt{2}$ km/h at an angle of 45° from east towards north. Thus, the given problem can be simplified as :

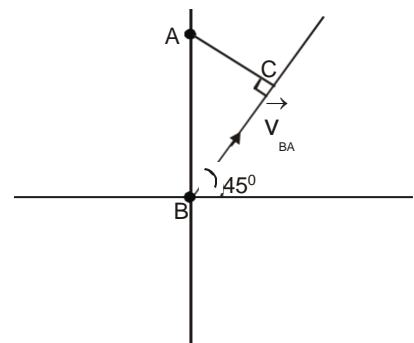
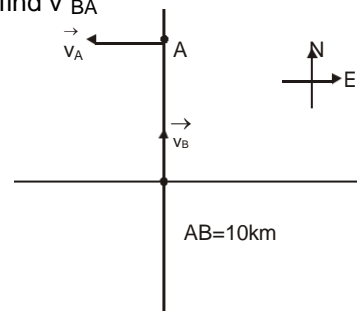
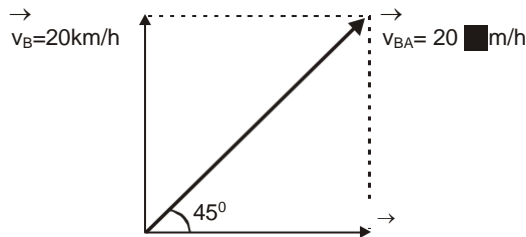

A is at rest and B is moving with v_{BA} in the direction shown in figure. Therefore, the minimum distance between the two is

$$s_{\min} = AC = AB \sin 45^\circ = 10 \left(\frac{1}{\sqrt{2}} \right) \text{ km} = 5\sqrt{2} \text{ km}$$

and the desired time is $t = \frac{BC}{|v_{BA}|} = \frac{5\sqrt{2}}{20\sqrt{2}} = \frac{1}{4} \text{ h} = 15 \text{ min}$

Example # 12

In the figure shown, the two projectile are fired simultaneously. Find the minimum distance between them during their flight.

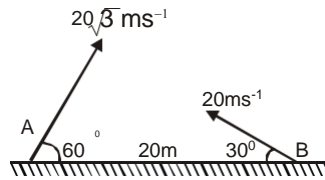

Solution

Taking origin at A and x axis along AB
Velocity of A w.r.t B

$$\begin{aligned}
 &= 20\sqrt{3}(\cos 60^\circ \hat{i} + \sin 60^\circ \hat{j}) - 20(\cos 150^\circ \hat{i} + \sin 150^\circ \hat{j}) \\
 &= \sqrt{\left(\frac{1}{2}\right)^2 + \left(\frac{\sqrt{3}}{2}\right)^2} - \left(\frac{\sqrt{3}}{2}\hat{i} + \frac{1}{2}\hat{j}\right) \\
 \tan \theta &= \frac{20}{20\sqrt{3}} = \frac{1}{\sqrt{3}} \Rightarrow \theta = 30^\circ \text{ SO } \frac{d_{\min}}{20} = \sin \theta = \sin 30^\circ = \frac{1}{2} \Rightarrow d_{\min} = 10\text{m}
 \end{aligned}$$

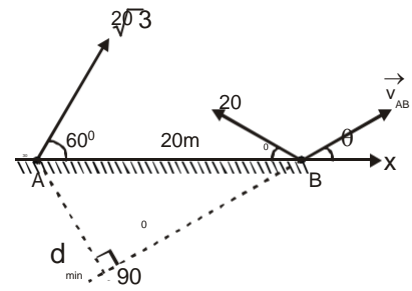

Example #13

Edujournal

A particle is dropped from the top of high building of height 360 m. The distance travelled by the particle in ninth second is ($g = 10 \text{ m/s}^2$)

- (A) 85 m (B) 60 m (C) 40 m (D) can't be determined

Solution

Ans. (C)

Total time taken by particle to reach the ground $T = \sqrt{\frac{2H}{g}} = \sqrt{\frac{2 \times 360}{10}} = 6\sqrt{2} = 8.484 \text{ s}$

Distance travelled in 8 seconds = $\frac{1}{2}gt^2 = \frac{1}{2}(10)(8)^2 = 320 \text{ m}$

Therefore distance travelled in ninth second = $360 - 320 = 40 \text{ m}$

Example #14

A ball is thrown from the ground to clear a wall 3 m high at a distance of 6 m and falls 18 m away from the wall, the angle of projection of ball is

- (A) $\tan^{-1} \left(\frac{3}{2} \right)$ (B) $\tan^{-1} \left(\frac{2}{3} \right)$ (C) $\tan^{-1} \left(\frac{1}{2} \right)$ (D) $\tan^{-1} \left(\frac{3}{4} \right)$

Solution

Ans. (B)

From equation of trajectory $y = x \tan \theta - \frac{g}{2v^2 \cos^2 \theta} x^2$ - $\left[\frac{x}{R} \right] \Rightarrow 3 = 6 \tan \theta - \frac{1}{4} \Rightarrow \tan \theta = \frac{2}{3}$

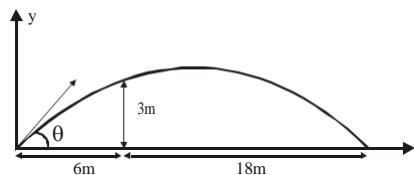

Example #15

A particle moves in XY plane such that its position, velocity and acceleration are given by

$$\vec{r} = x\hat{i} + y\hat{j} ; \vec{v} = v_x\hat{i} + v_y\hat{j} ; \vec{a} = a_x\hat{i} + a_y\hat{j}$$

which of the following condition is correct if the particle is speeding down?

- (A) $xv_x + yv_y < 0$ (B) $xv_x + yv_y > 0$ (C) $a_xv_x + a_yv_y < 0$ (D) $a_xv_x + a_yv_y > 0$

Solution

Ans. (C)

For speeding down $\vec{a} \cdot \vec{v} < 0 \Rightarrow a_xv_x + a_yv_y < 0$

Example #16

A particle is thrown vertically upwards from the surface of the earth. Let T_P be the time taken by the particle to travel from a point P above the earth to its highest point and back to the point P. Similarly, let T_Q be the time taken by the particle to travel from another point Q above the earth to its highest point and back to the same point Q. If the distance between the points P and Q is H, the expression for acceleration due to gravity in terms of T_P , T_Q and H, is :-

- (A) $\frac{6H}{T_P^2 + T_Q^2}$ (B) $\frac{8H}{T_P^2 - T_Q^2}$ (C) $\frac{2H}{T_P^2 + T_Q^2}$ (D) $\frac{H}{T_P^2 - T_Q^2}$

Solution

Ans. (B)

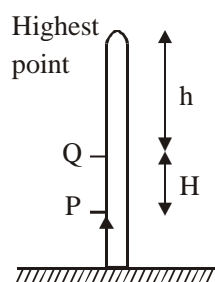

Edujournal

Time taken from point P to point P

$$T_P = 2\sqrt{\frac{2(h+H)}{g}}$$

Time taken from point Q to point Q

$$T_Q = 2\sqrt{\frac{2h}{g}}$$

$$\Rightarrow T_P^2 = \frac{8(h+H)}{g} \text{ and } T_Q^2 = \frac{8h}{g} \Rightarrow T_P^2 - T_Q^2 = \frac{8H}{g} \Rightarrow g = \frac{8H}{T_P^2 - T_Q^2}$$

Example #17

An aeroplane is travelling horizontally at height of 2000 m from the ground. The aeroplane, when at a point P, drops a bomb to hit a stationary target Q on the ground. In order that the bomb hits the target, what angle θ must the line PQ make with the vertical? [$g = 10\text{ms}^{-2}$]

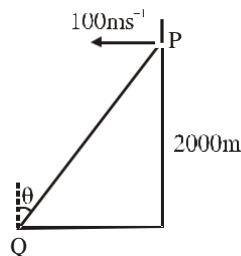

- (A) 15° (B) 30° (C) 90° (D) 45°

Solution :

Ans. (D)

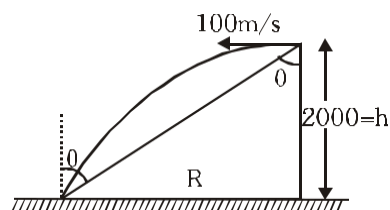

Let t be the time taken by bomb to hit the target.

$$h = 2000 = \frac{1}{2}gt^2 \Rightarrow t = 20 \text{ sec}$$

$$R = ut = (100)(20) = 2000 \text{ m}$$

$$\tan \theta = \frac{R}{h} = \frac{2000}{2000} = 1 \Rightarrow \theta = 45^\circ$$

Example #18

Some informations are given for a body moving in a straight line. The body starts its motion at $t=0$.

Information I : The velocity of a body at the end of 4s is 16 m/s

Information II : The velocity of a body at the end of 12s is 48 m/s

Information III : The velocity of a body at the end of 22s is 88 m/s

The body is certainly moving with

- (A) Uniform velocity (B) Uniform speed
(C) Uniform acceleration (D) Data insufficient for generalization

Solu ti on

Ans. (D)

$$\text{Here average acceleration} = \frac{16-0}{4-0} = \frac{48-16}{12-4} = \frac{88-48}{22-12} = 4$$

But we can't say certainly that body have uniform acceleration.

Example #19

A large number of particles are moving each with speed v having directions of motion randomly distributed. What is the average relative velocity between any two particles averaged over all the pairs?

- (A) v (B) $(\pi/4)v$ (C) $(4/\pi)v$ (D) Zero

Solution :

A ball is projected as shown in figure. The ball will return to point :

Ans. (C)

Relative velocity , $v_r = |v_1 - v_2|$ where $v_1 = v_2 = v$

$$\text{If angle between them be } \theta, \text{ then } v_r = \sqrt{v^2 + v^2 - 2v^2 \cos \theta} = \sqrt{2v^2(1 - \cos \theta)} = 2v \sin \left(\frac{\theta}{2} \right)$$

$$\text{Hence, average relative velocity } v = \frac{\int_0^{2\pi} 2v \sin \frac{\theta}{2} d\theta}{\int_0^{2\pi} d\theta} = \frac{4v}{\pi}$$

Example #20

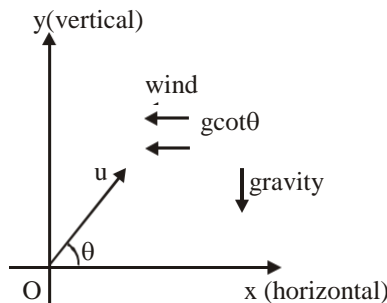

- (A) O (B) left to point O (C) right to point O (D) none of these

Solution :

Ans. (A)

$$\text{Here } a_x = \frac{g \cot \theta}{g} = \frac{1}{\tan \theta} = \frac{u_x}{u_y} \Rightarrow \text{Initial velocity \& acceleration are opposite to each other.}$$

\Rightarrow Ball will return to point O.

Example #21

Throughout a time interval, while the speed of a particle increases as it moves along the x-axis, its velocity and acceleration might be

- (A) positive and positive respectively.
- (B) positive and negative respectively.
- (C) negative and negative respectively.
- (D) negative and positive respectively.

Solution :

Ans. (A, C)

Speed increases if both velocity & acceleration have same signs.

Example #22

Three point particles A, B and C are projected from same point with same speed at $t=0$ as shown in figure. For this situation select correct statement(s).

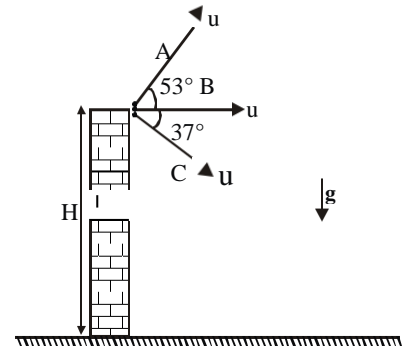

- (A) All of them reach the ground at same time.
- (B) All of them reach the ground at different time.
- (C) All of them reach the ground with same speed.
- (D) All of them have same horizontal displacement when they reach the ground.

Solution :

Ans. (B, C)

Vertical component of initial velocities are different \Rightarrow reach the ground at different time.

Example #23

A projectile is thrown with speed u into air from a point on the horizontal ground at an angle θ with horizontal. If the air exerts a constant horizontal resistive force on the projectile then select correct alternative(s).

- (A) At the farthest point, the velocity is horizontal.
- (B) The time for ascent equals the time for descent.
- (C) The path of the projectile may be parabolic.
- (D) The path of the projectile may be a straight line.

Solution :

Ans. (C,D)

Here total acceleration $a = -g$ (constant), so path may be parabolic or straight line.

Example #24 to 26

A river of width 'd' with straight parallel banks flows due North with speed u . A boat, whose speed is v relative to water, starts from A and crosses the river. If the boat is steered due West and u varies with y as $u = \frac{y(d-y)v}{d^2}$ then answer the following questions.

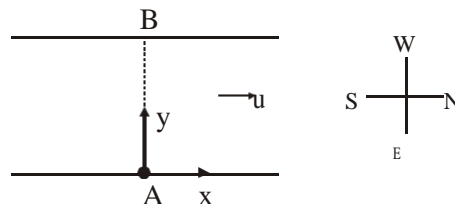

24 . The time taken by boat to cross the river is

- (A) $\frac{d}{\sqrt{2}v}$
- (B) $\frac{d}{v}$
- (C) $\frac{d}{2v}$
- (D) $\frac{2d}{v}$

25. Absolute velocity of boat when it reaches the opposite bank is

- (A) $\frac{4}{3}v$, towards East (B) v , towards West (C) $\frac{4}{3}v$, towards West (D) v , towards East

26. Equation of trajectory of the boat is

- (A) $y = \frac{x^2}{2d}$ (B) $x = \frac{y^2}{2d}$ (C) $y = \frac{x^2}{2d} - \frac{x^3}{3d^2}$ (D) $x = \frac{y^2}{2d} - \frac{y^3}{3d^2}$

Solution :

24. **Ans. (B)**

$$\text{Time taken} = \frac{d}{v_y} = \frac{d}{v}$$

25. **Ans. (B)**

At $y=d$, $u=0$ so absolute velocity of boat = v towards West.

26. **Ans. (D)**

For boat (w.r.t. ground) $v_y = v$, $v_x = u = \frac{y(d-y)}{d^2}v \Rightarrow \frac{dy}{dt} = v$ and $\frac{dx}{dt} = \frac{y(d-y)}{d^2}v$

$$\Rightarrow \frac{dx}{dy} = \frac{y(d-y)}{d} \Rightarrow \int_0^x dx = \int_0^y \frac{y(d-y^2)}{d} dy \Rightarrow x = \frac{y^2}{2d} - \frac{y^3}{3d^2}$$

Example #27

As shown in the figure there is particle of mass $\sqrt{3}$ kg, is projected with speed 10 m/s at an angle 30° with horizontal (take $g = 10 \text{ m/s}^2$) then match the following

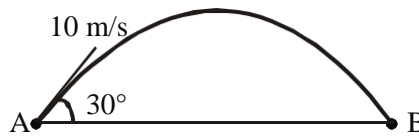

Column I

- (A) Average velocity (in m/s) during half of the time of flight, is
- (B) The time (in sec) after which the angle between velocity vector and initial velocity vector becomes $\pi/2$, is
- (C) Horizontal range (in m), is
- (D) Change in linear momentum (in N-s) when particle is at highest point, is

Column II

- (P) $\frac{1}{2}$
- (Q) $\frac{5}{2}\sqrt{13}$
- (R) $5\sqrt{3}$
- (S) At an angle of $\tan^{-1}\left(\frac{1}{2\sqrt{3}}\right)$ from horizontal
- (T) 2

Solution :

Ans. (A) → (Q,S); (B) → (T); (C) → (R); (D) → (R)

For (A) : $v_{av} = \sqrt{(v_{avx})^2 + (v_{avy})^2} = \sqrt{(10 \cos 30^\circ)^2 + \left(\frac{10 \sin 30^\circ + 0}{2}\right)^2} = \sqrt{75 + \frac{25}{4}} = \frac{5}{2}\sqrt{13} \text{ m/s}$

Angle with horizontal $\theta = \tan^{-1}\left(\frac{v_{avy}}{v_{avx}}\right) = \tan^{-1}\left(\frac{-1(5/2)}{5\sqrt{3}}\right) = \tan^{-1}\left(\frac{1}{2\sqrt{3}}\right)$

For (B) : By using $v = u + at$ We have $gt = u \sin 30^\circ \Rightarrow t = (10)(1/2) = 2$

For (C) : Horizontal range(R) = $\frac{u^2 \sin 2\theta}{g} = \frac{100 \times \sqrt{3}/2}{10} = 5\sqrt{3} \text{ m}$

For (D) : Change in linear momentum = $mu_y = \sqrt{3} \times 10 \sin 30^\circ = 5\sqrt{3} \text{ N-s}$

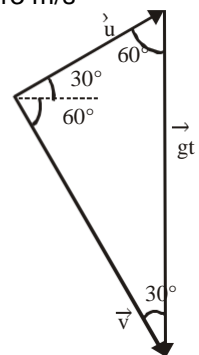

Example #28

A particle is moving along a straight line along x-axis with an initial velocity of 2 m/s towards positive x-axis. A constant acceleration of 0.5 m/s² towards negative x-axis starts acting on particle at t=0. Find velocity (in m/s) of particle at t = 2s.

Solution :

Ans. 1

$$v = u + at \Rightarrow v = 2 + (-0.5)(2) = 1 \text{ m/s}$$

Example #29

In the given figure points A and C are on the horizontal ground & A and B are in same vertical plane. Simultaneously bullets are fired from A, B and C and they collide at D. The bullet at B is fired horizontally with

speed of $\frac{72}{5}$ km/hr and the bullet at C is projected

vertically upward at velocity of $\frac{54}{5}$ km/hr. Find velocity of the bullet projected from A in m/s.

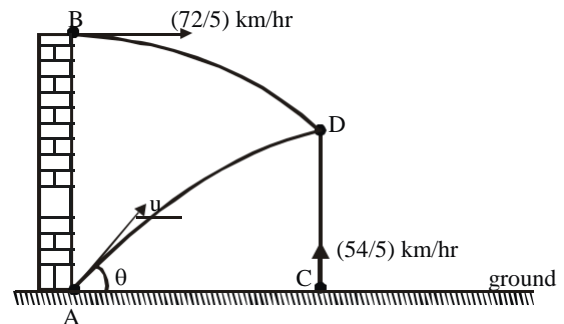

Solution :

Ans. 5

$$\text{For collision } u = u_B \sqrt{\frac{2}{5} + \frac{2}{18}} = \sqrt{\left(\frac{72}{5} \times \frac{5}{18}\right)^2 + \left(\frac{54}{5} \times \frac{5}{18}\right)^2} = \sqrt{4^2 + 3^2} = 5 \text{ m/s}$$

Example #30

Two stones A and B are projected simultaneously as shown in figure. It has been observed that both the stones reach the ground at the same place after 7 sec of their projection. Determine difference in their vertical components of initial velocities in m/s. (g = 9.8 m/s²)

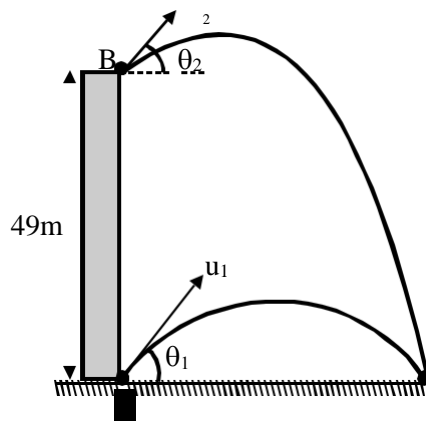

Solution :

Ans. 7

In time of flight i.e. 7 s, the vertical displacement of A is zero and that of B is 49 m so for relative motion of B w.r.t. A $(u_2 \sin \theta_2 - u_1 \sin \theta_1) \times 7 = 49 \Rightarrow u_2 \sin \theta_2 - u_1 \sin \theta_1 = 7 \text{ m/s}$

Example #31

A particle moves with a tangential acceleration $a_t = a \hat{t}$ where $a = (5i) \text{ m/s}^2$. If the speed of the particle is zero at $x=0$, then find v (in m/s) at $x = 4.9 \text{ m}$.

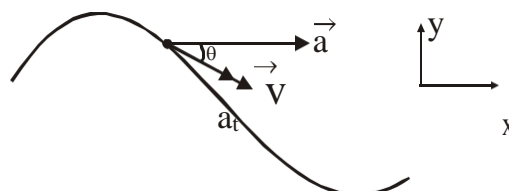

Solution :

Ans. 7

$$\text{As } v dv = a \cdot dr = a dx = 5 dx \Rightarrow \int_0^v v dv = 5 \int_0^v dx \Rightarrow \frac{v^2}{2} = 5(4.9) \Rightarrow v^2 = 49 \Rightarrow v = 7 \text{ m/s}$$

Example #32

A body is thrown up with a speed 49 m/s. It travels 5 m in the last second of its upward journey. If the same body is thrown up with a velocity 98 m/s, how much distance (in m) will it travel in the last second. ($g = 10 \text{ m/s}^2$)

Solution :

Ans. 5

In last second of upward journey, all bodies travel same distance ($= g/2 = 5\text{m}$)

Example #33

A particle is moving in a circle of radius R in such a way that at any instant the normal and the tangential component of its acceleration are equal. If its speed at $t=0$ is v_0 then the time it takes to complete the first revolution is

$$\frac{R}{\alpha v_0} (1 - e^{-\beta \pi}). \text{ Find the value of } (\alpha + \beta).$$

Solution :

Ans. 3

$$\frac{dv}{dt} = \frac{v^2}{R} \Rightarrow \frac{dv}{v^2} = \frac{1}{R} dt \Rightarrow \left(-\frac{1}{v}\right)_0^v = \frac{t}{R} \Rightarrow v = \frac{v_0}{1 - \frac{v_0}{R}t} \Rightarrow \frac{ds}{dt} = \frac{v_0}{1 - \frac{v_0}{R}t} \Rightarrow \int_0^{2\pi R} ds = \int_0^t \frac{v_0}{1 - \frac{v_0}{R}t} dt$$

Edujournal

$$\Rightarrow 2\pi R = -R \ln \left(1 - \frac{v_0}{R}t\right) \Big|_0^t \Rightarrow 2\pi = -\ln \left(1 - \frac{v_0}{R}t\right) \Rightarrow 1 - \frac{v_0}{R}t = e^{-2\pi} \Rightarrow t = \frac{R}{v_0} (1 - e^{-2\pi})$$

$$\Rightarrow \alpha=1, \beta=2 \Rightarrow (\alpha+\beta)=(1+2)=3$$

Example #34

Find the relation between acceleration of blocks 1, 2 and 3.

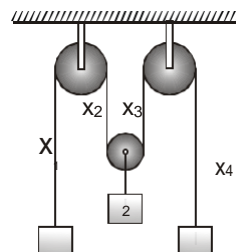

Solution

$$\begin{aligned} X_1 + X_2 + X_3 + X_4 &= 0 \\ \Rightarrow X_1 + X_2 + X_3 + X_4 &= 0 \\ \Rightarrow a_1 + a_2 + a_2 + a_3 &= 0 \\ \Rightarrow a_1 + 2a_2 + a_3 &= 0 \end{aligned}$$

Example #35

Two moving particles P and Q are 10 m apart at any instant. Velocity of P is 8 m/s at 30° , from line joining the P and Q and velocity of Q is 6m/s at 30° . Calculate the angular velocity of P w.r.t. Q

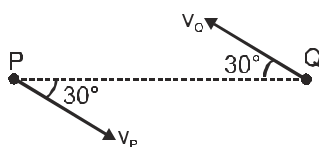

Solution

$$\omega_{PQ} = \frac{8 \sin 30 - (-6 \sin 30)}{10} = 0.7 \text{ rad/s.}$$